

## **VIN marking area for K5 model**

1. Hood
2. Trunk Lid
3. Front Fender (LH/RH)
4. Front Door (LH/RH)
5. Rear Door (LH/RH)
6. Side Outer Panel (LH/RH)
7. Front Bumper
8. Rear Bumper
9. Engine
10. Transmission (8DCT, 8AT)



# Hood

TARGET AREA FOR  
REPLACEMENT PART

TARGET AREA FOR  
ORIGINALLY EQUIPPED PART

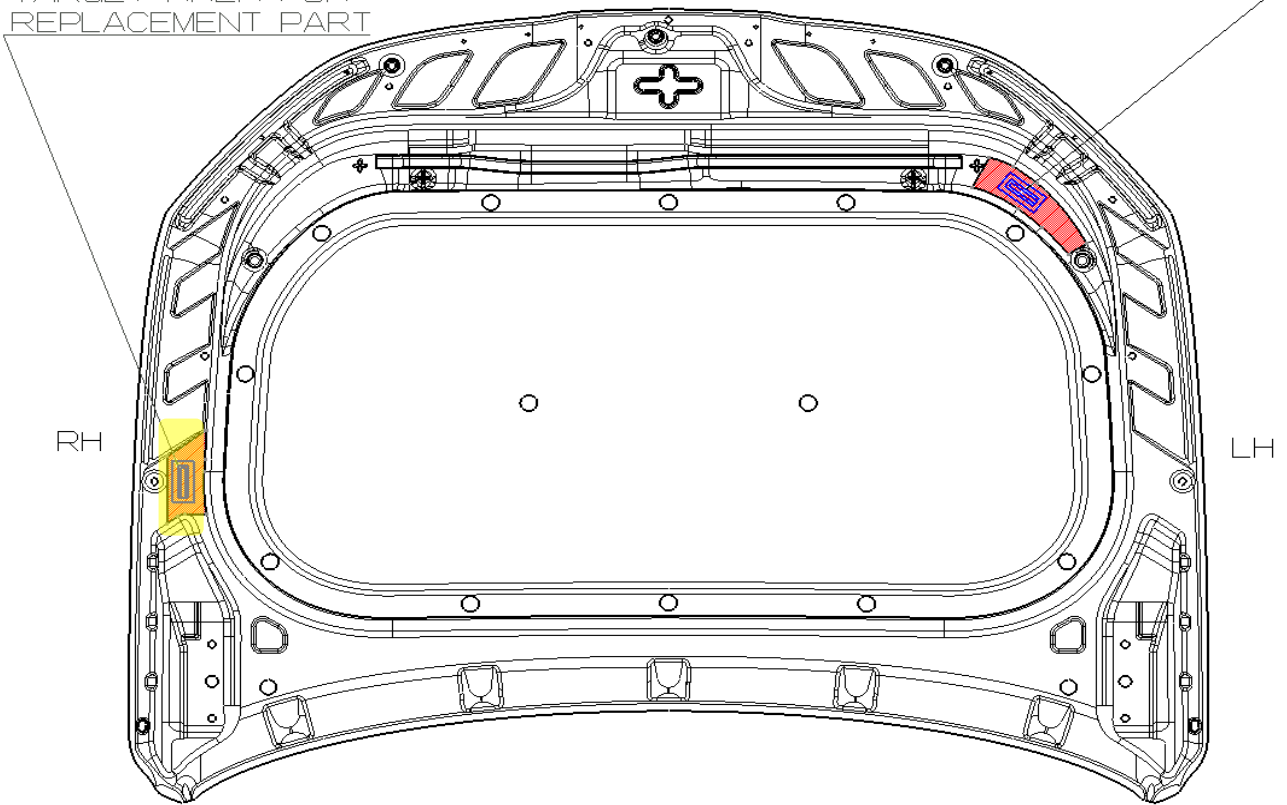

 Originally Equipped Part

 Replacement Part

# Trunk Lid

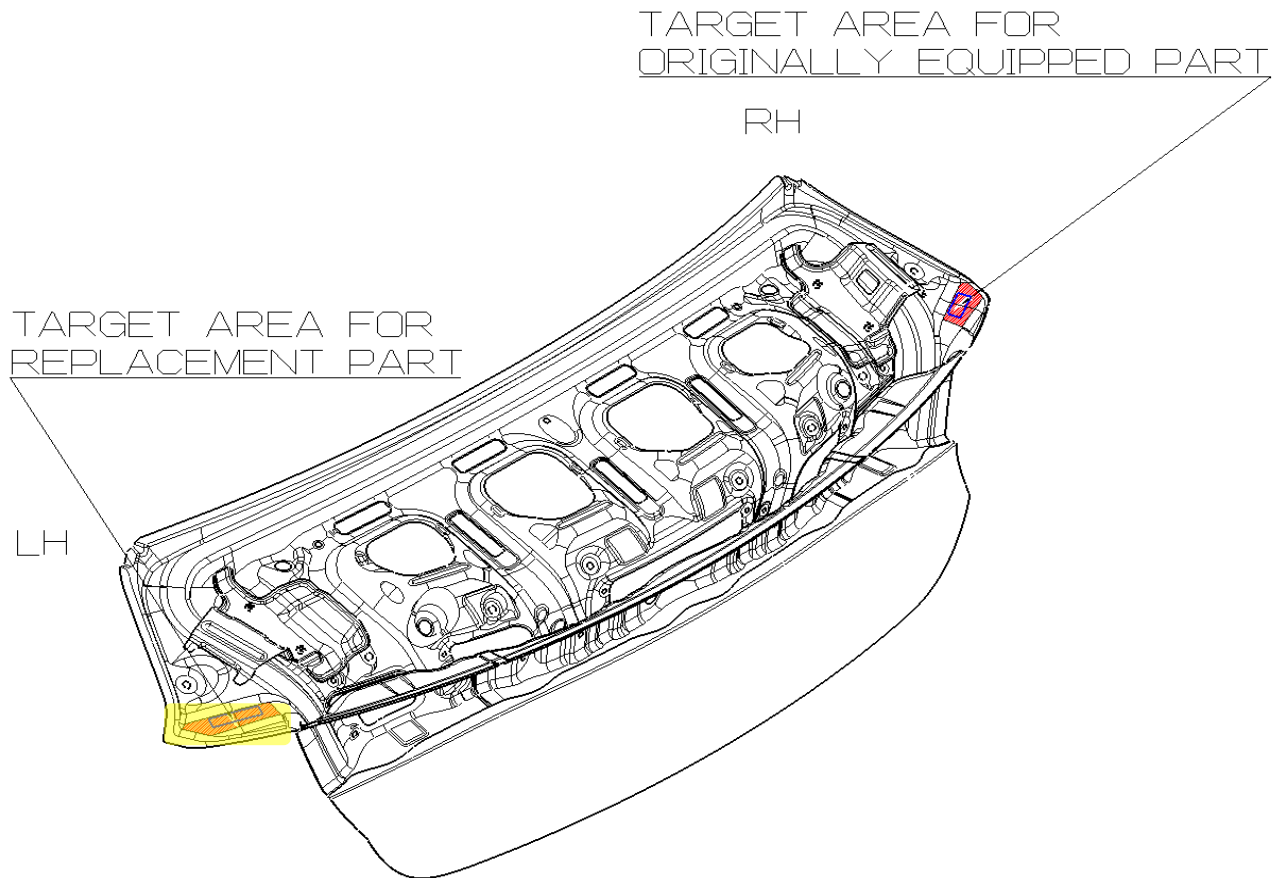

Originally Equipped Part



Replacement Part

# Front Fender (LH/RH)

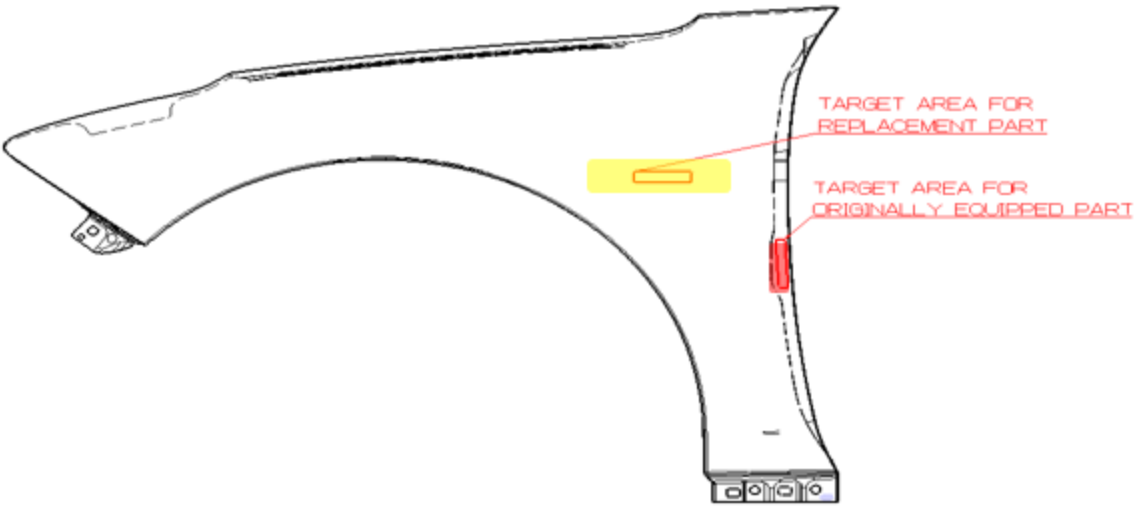
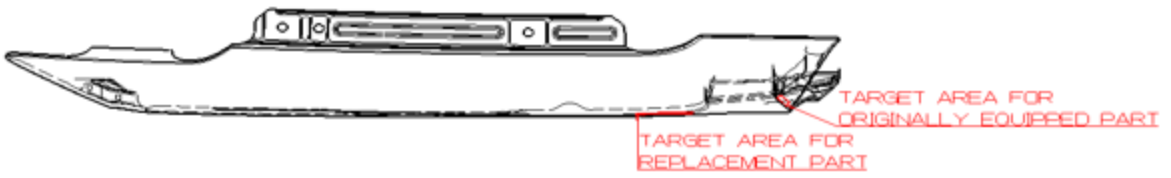

 Originally Equipped Part

 Replacement Part

# Front Door (LH/RH)

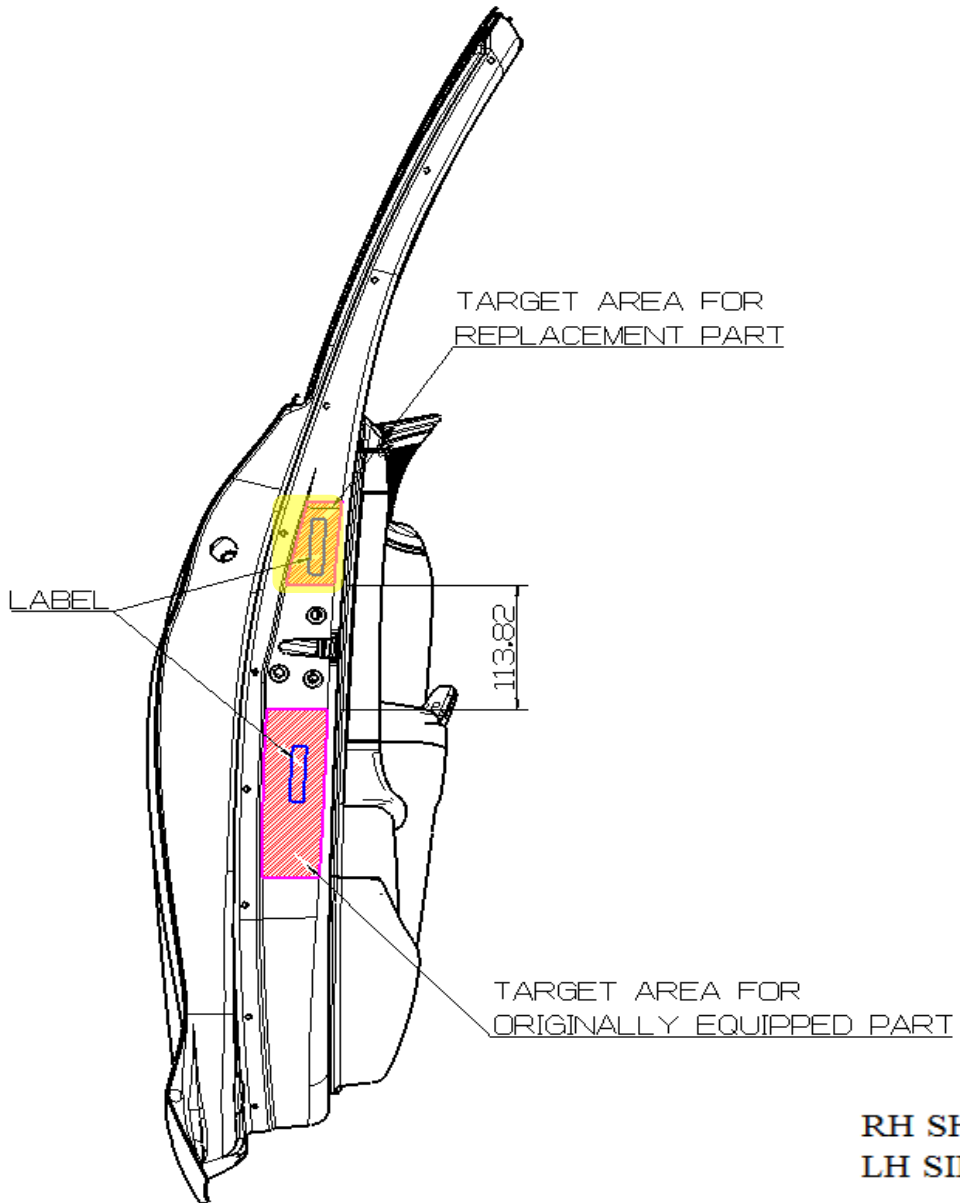

 Originally Equipped Part

 Replacement Part

# Rear Door (LH/RH)

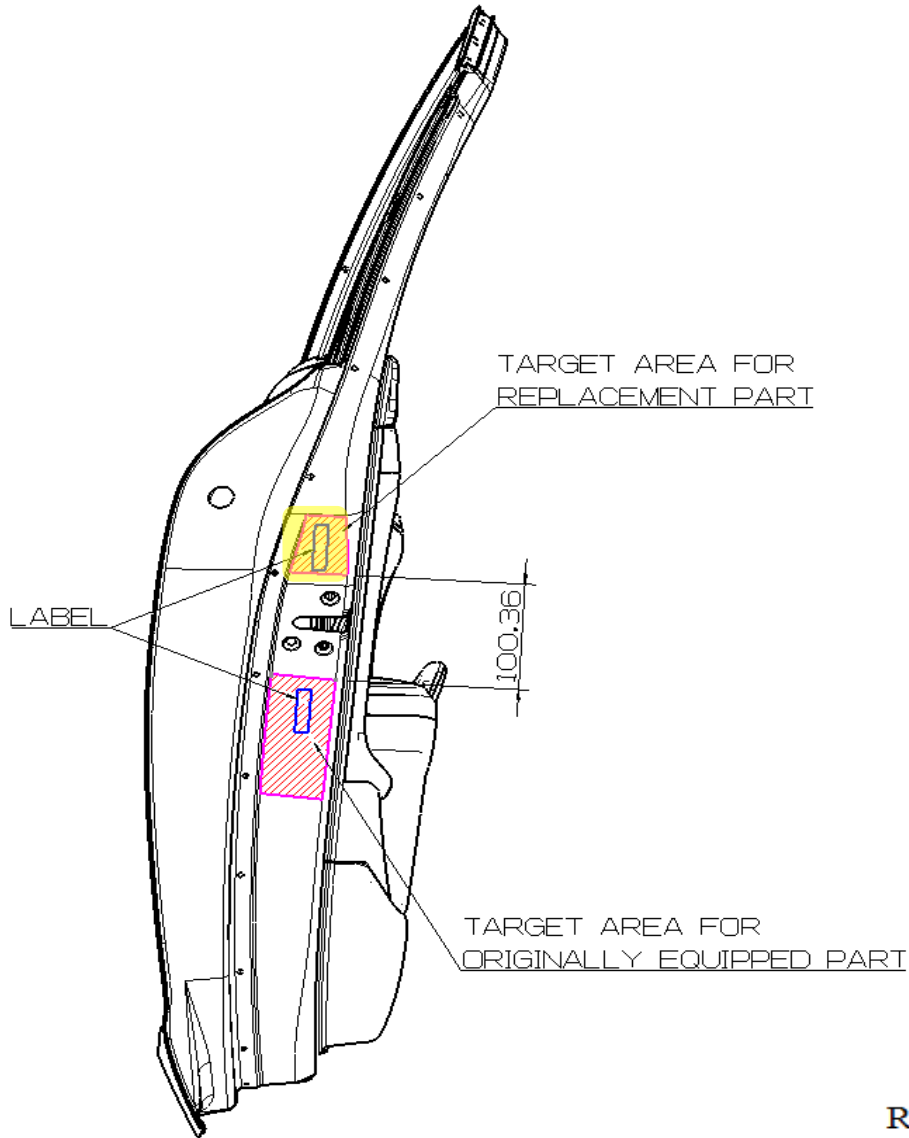

RH SHOWN  
LH SIMILAR

 Originally Equipped Part

 Replacement Part

# Side Outer Panel (LH/RH)

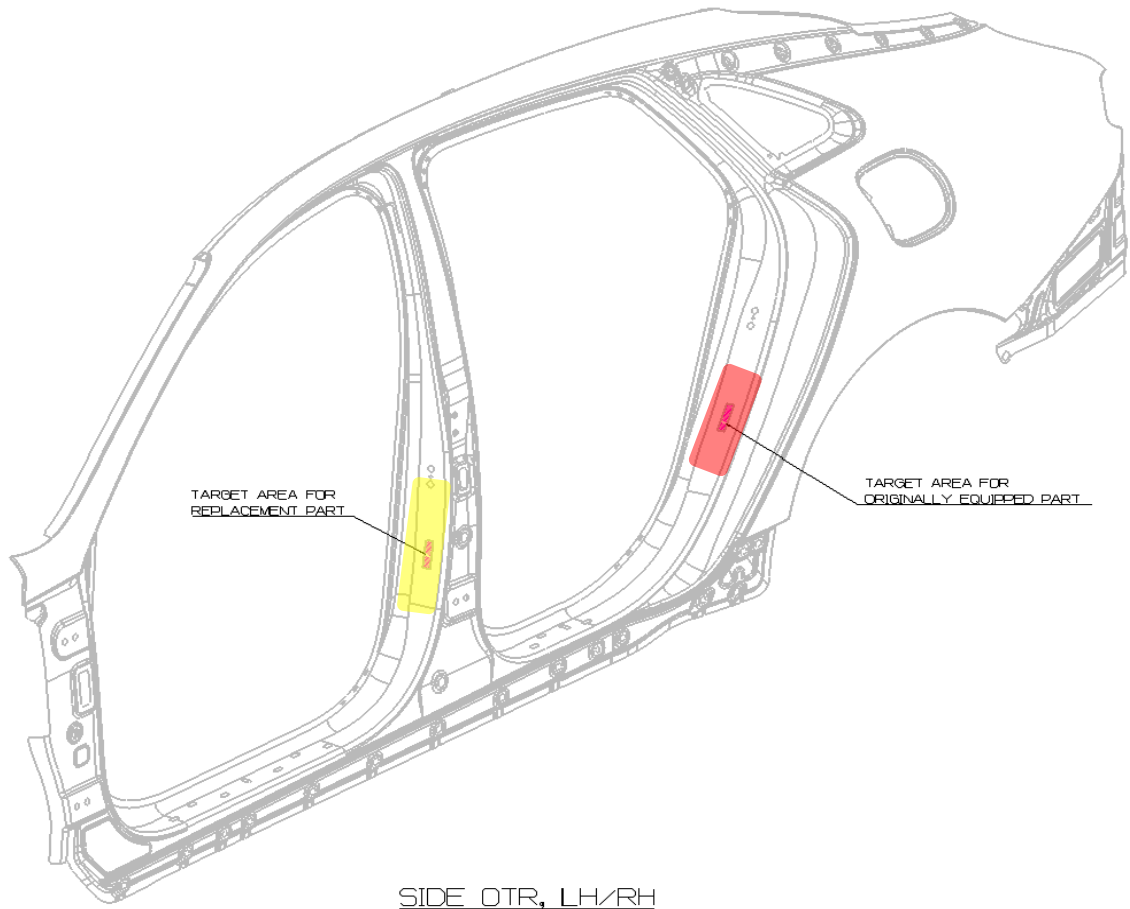

Originally Equipped Part



Replacement Part

# Front Bumper

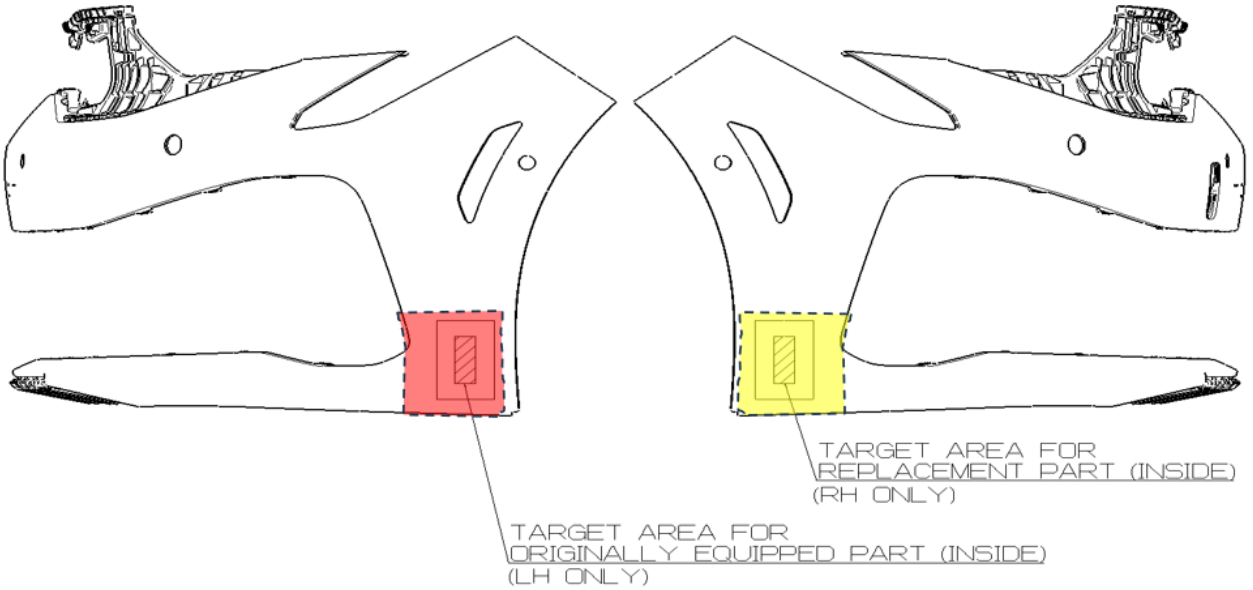

Originally Equipped Part



Replacement Part



# Rear Bumper

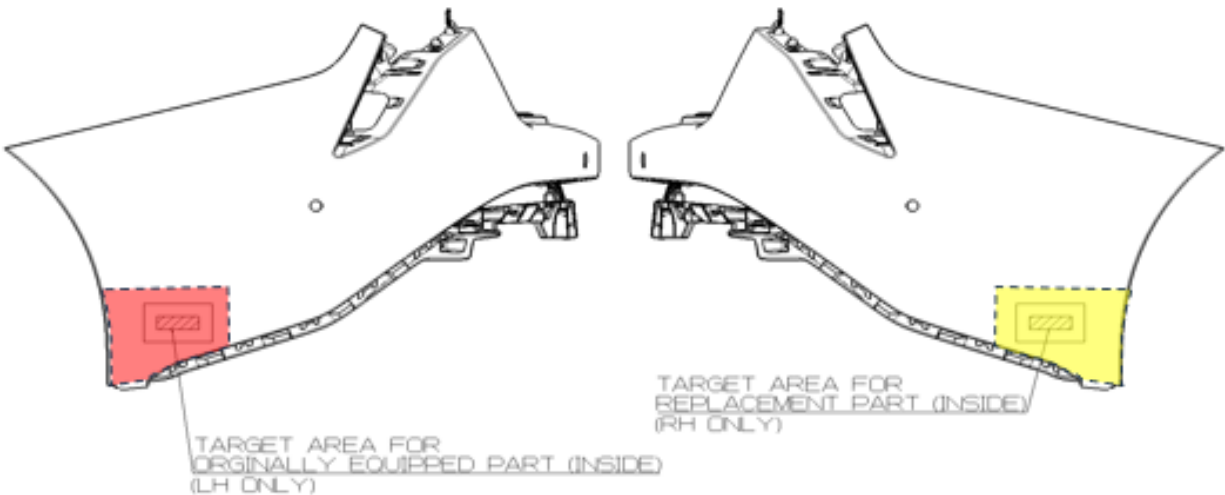

Originally Equipped Part



Replacement Part

# Engine

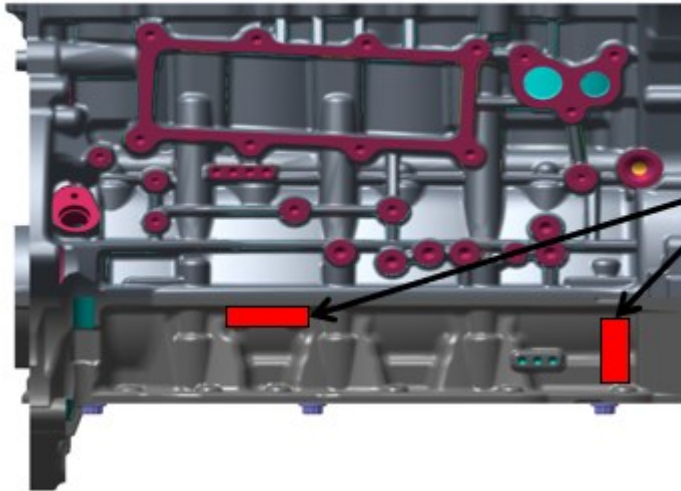

TARGET AREA FOR ORIGINALLY  
EQUIPPED PART  
(VIN PLATE)



TARGET AREA FOR REPLACEMENT  
PART



Originally Equipped Part



Replacement Part

# Transmission (8DCT)

TARGET AREA FOR REPLACEMENT PART

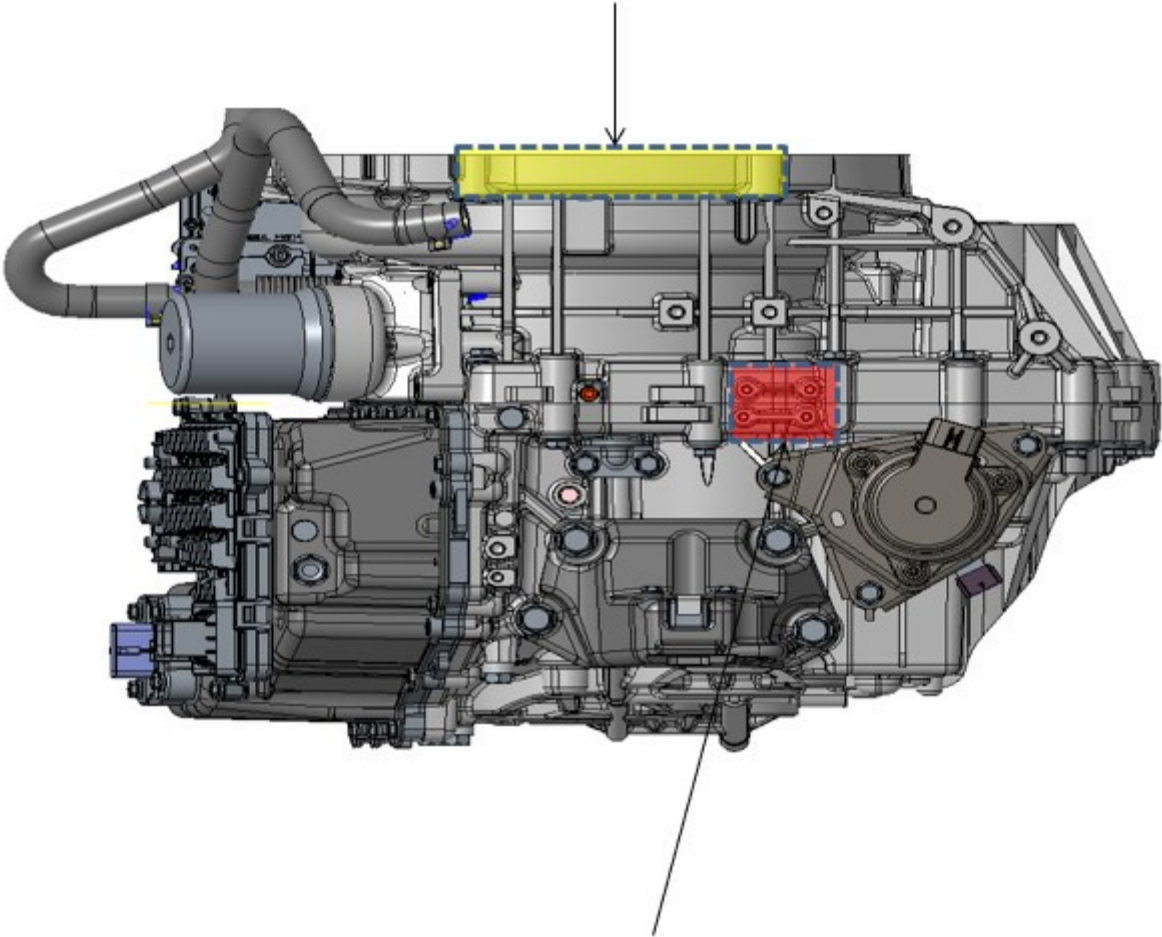

TARGET AREA FOR ORIGINALLY EQUIPPED PART



Originally Equipped Part



Replacement Part

# Transmission (8AT)

TARGET AREA FOR REPLACEMENT PART

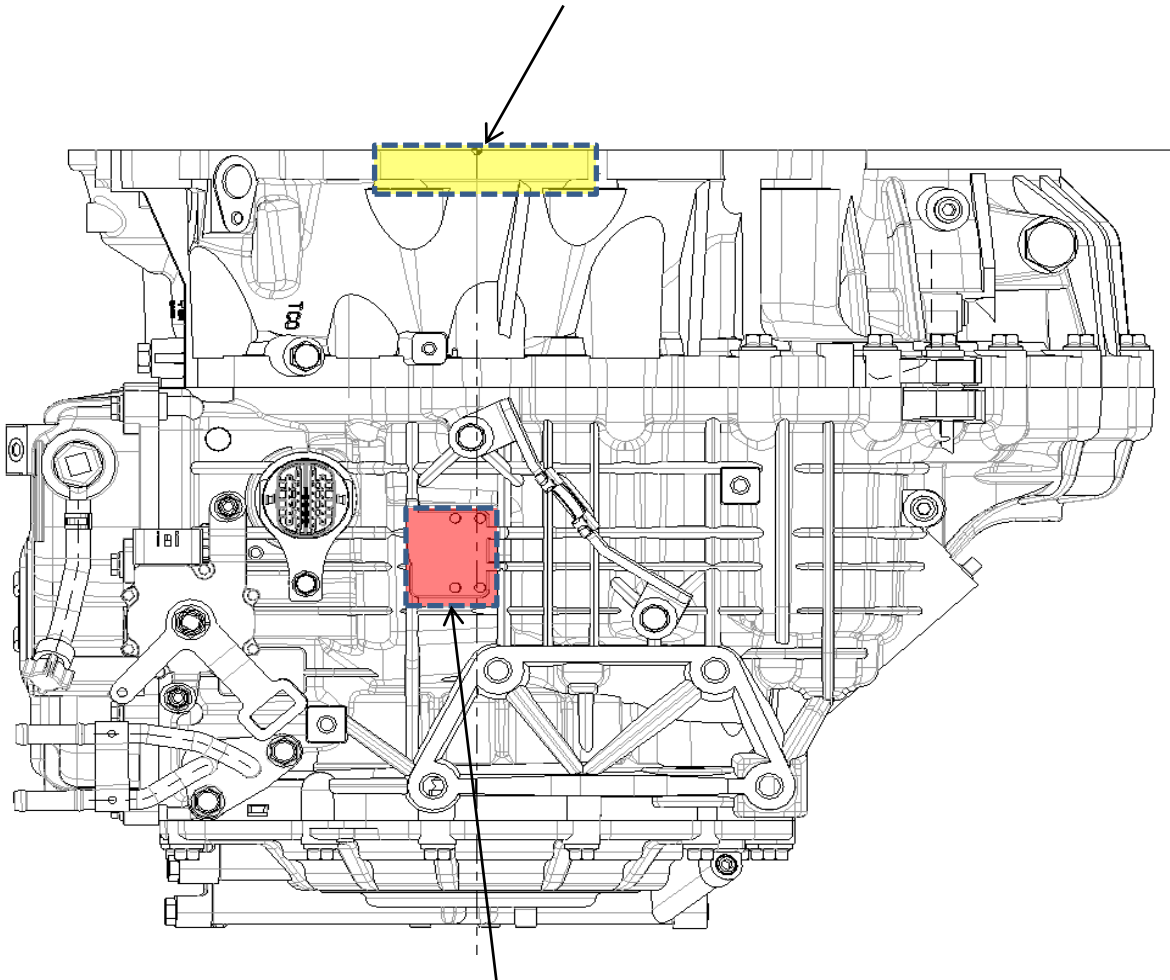

TARGET AREA FOR ORIGINALLY EQUIPPED PART



Originally Equipped Part



Replacement Part