

VIN marking area for EV9 model

- 1. Hood**
- 2. Tail Gate**
- 3. Front Fender (LH/RH)**
- 4. Front Door (LH/RH)**
- 5. Rear Door (LH/RH)**
- 6. Side Outer Panel (LH/RH)**
- 7. Front Bumper**
- 8. Rear Bumper**
- 9. Motor (FR/RR)**



Hood

TARGET AREA FOR
REPLACEMENT PART

RH

TARGET AREA FOR
ORIGINALLY EQUIPPED PART

LH

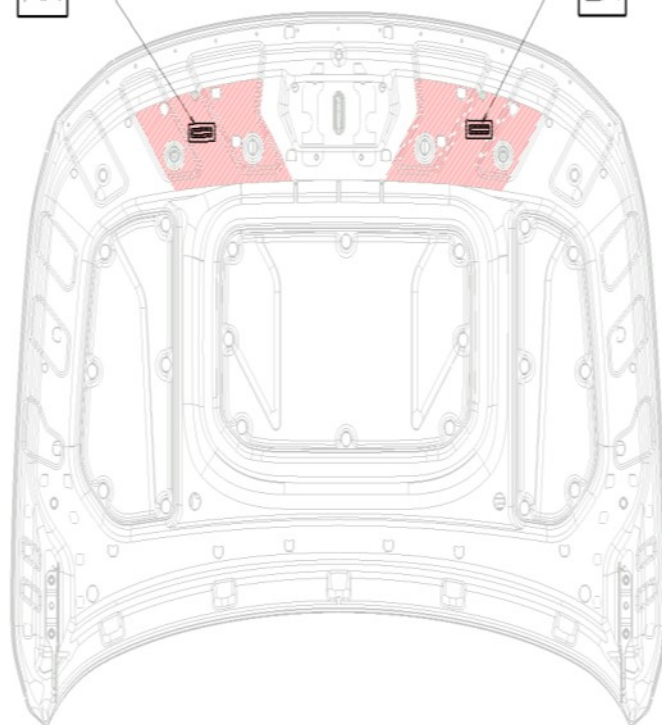

Tail Gate

TARGET AREA FOR
REPLACEMENT PART
CHINA IS NOT APPLIED

TARGET AREAR FOR
ORIGINALLY EQUIPPED PART



Front Fender (LH/RH)

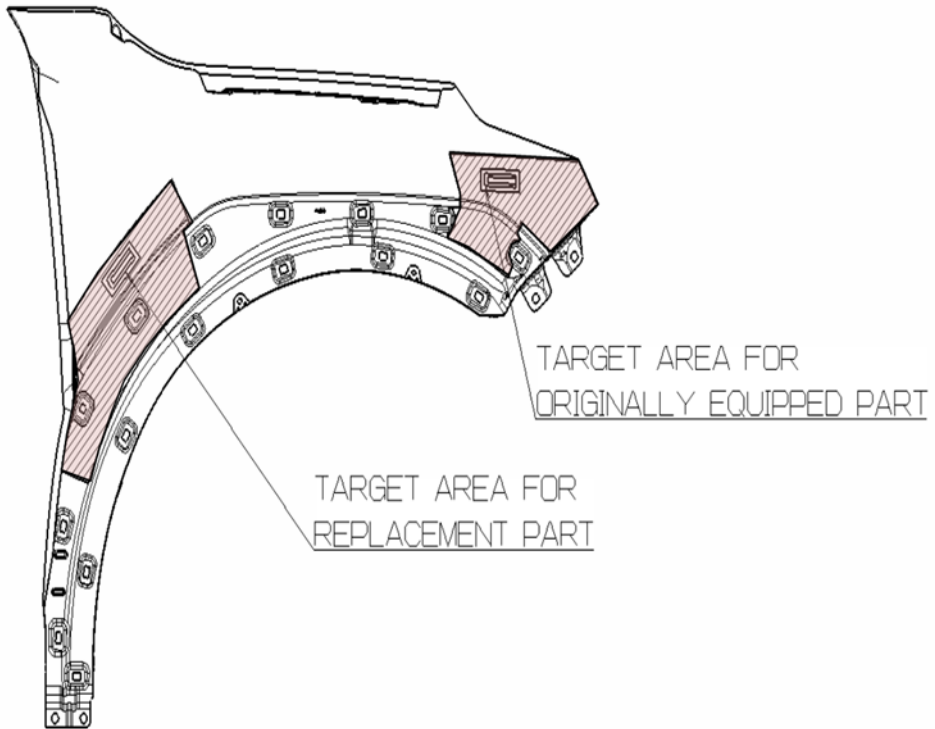

PNL-FENDER, LH/RH

Front Door (LH/RH)

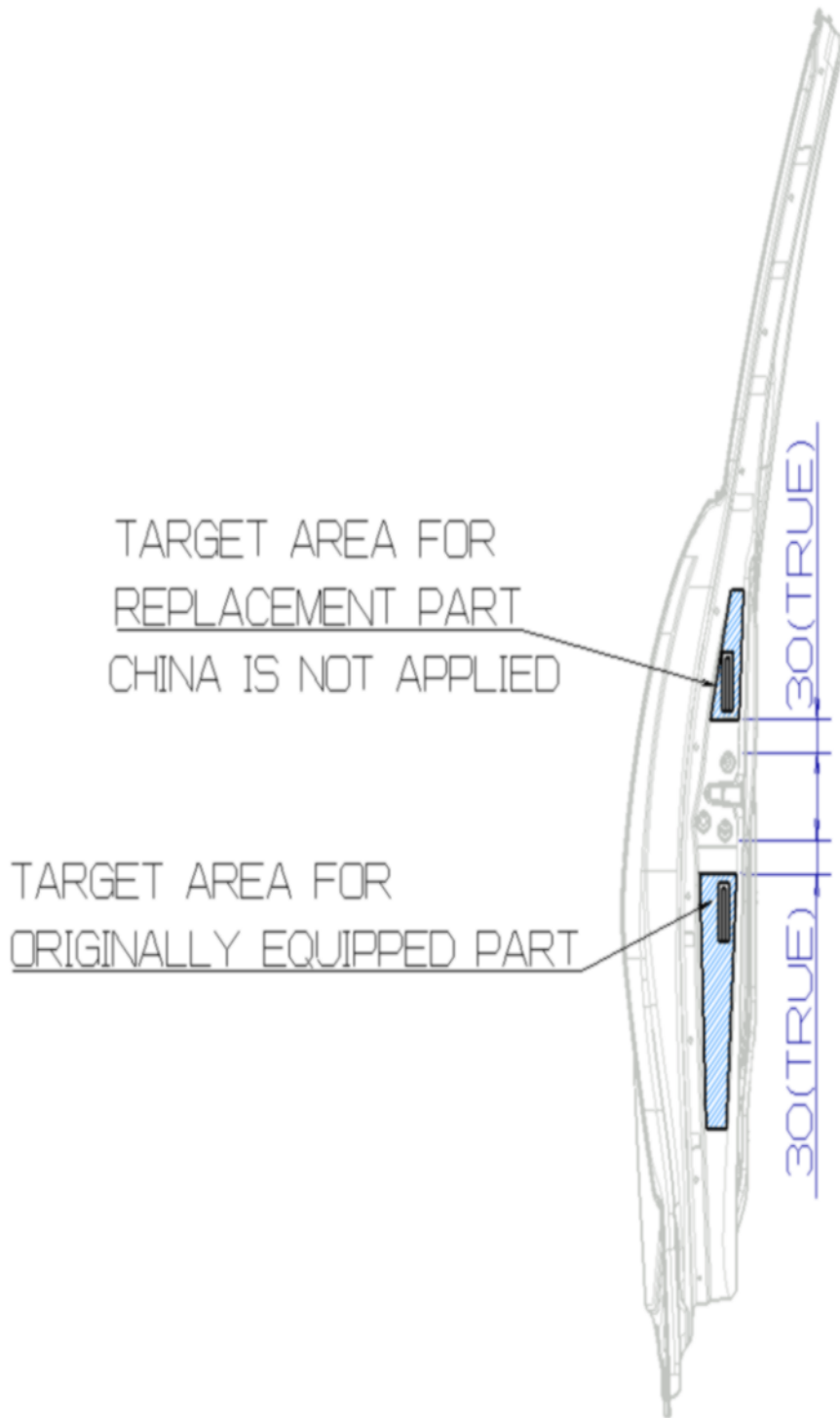

Rear Door (LH/RH)

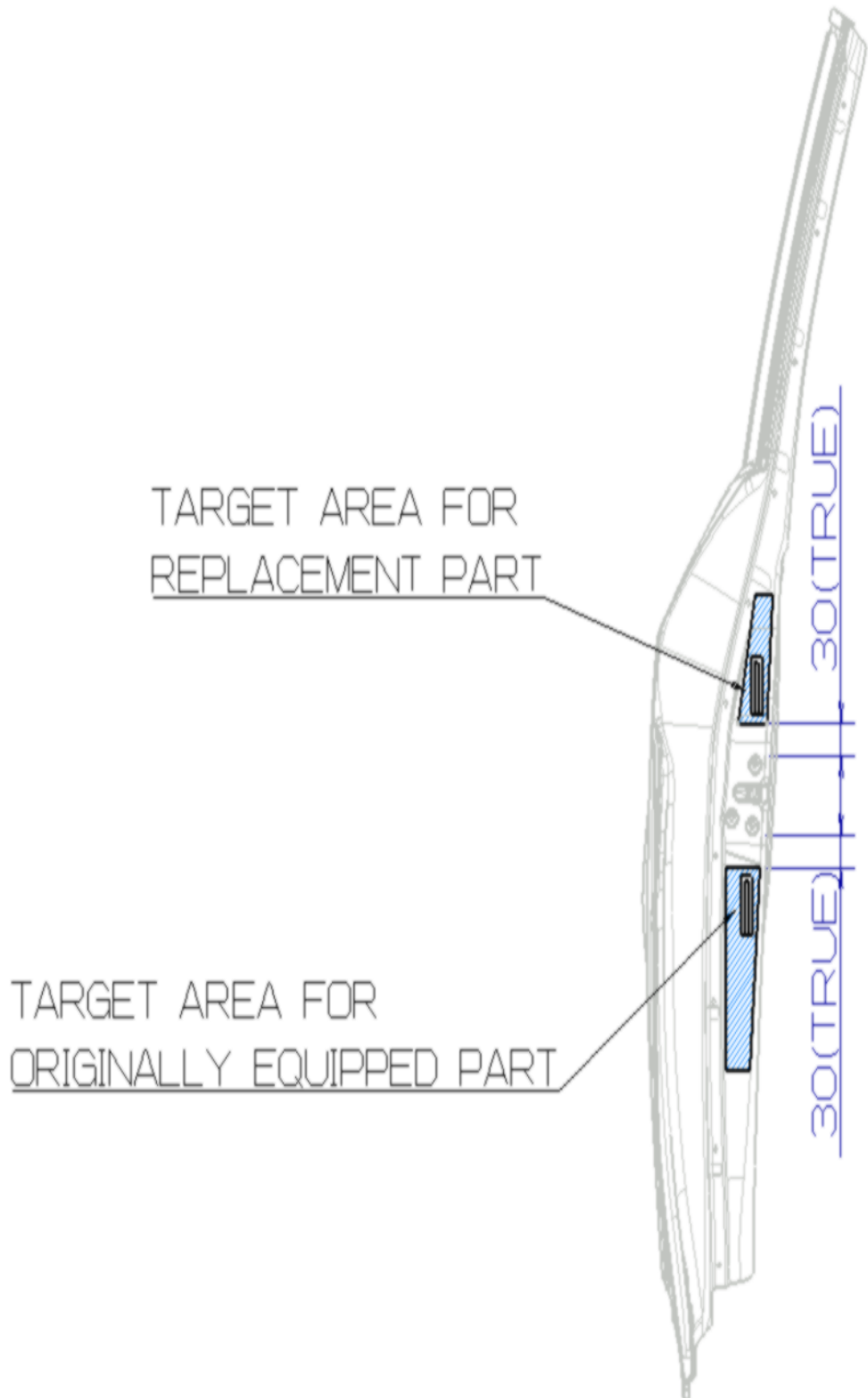

Side Outer Panel (LH/RH)

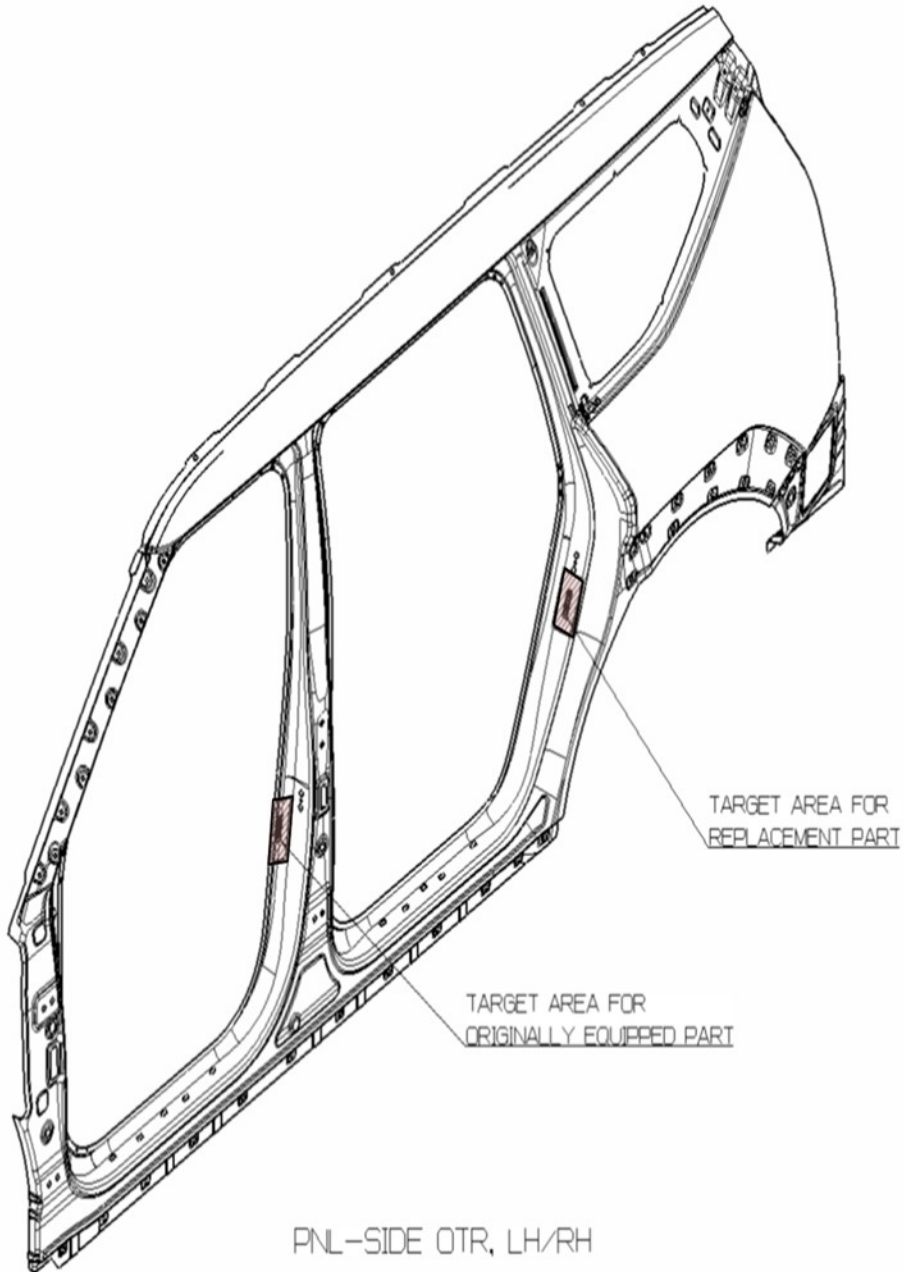

Front Bumper (STD)

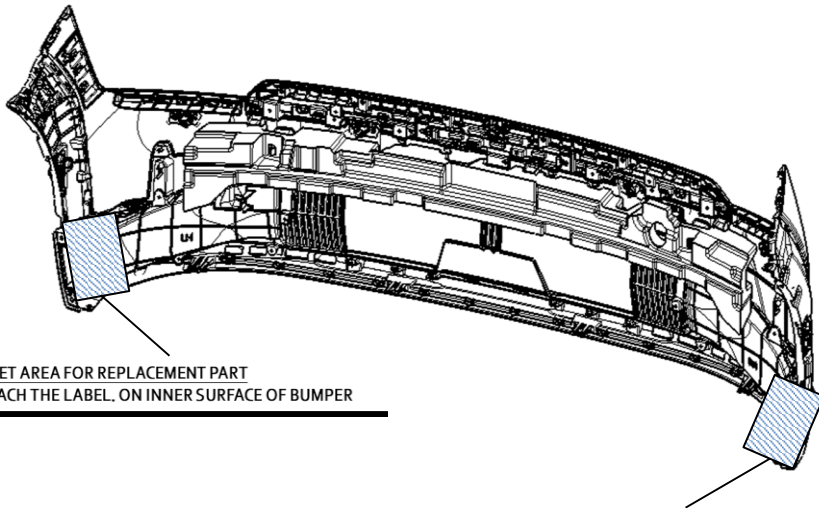
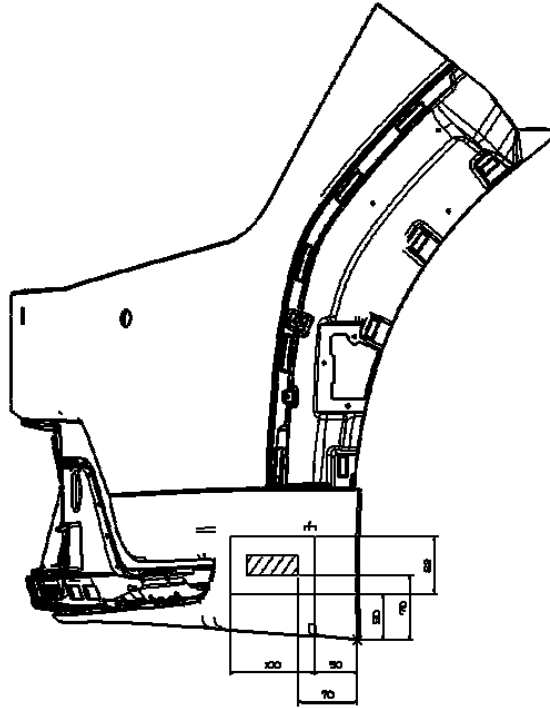

TARGET AREA FOR REPLACEMENT PART
: ATTACH THE LABEL, ON INNER SURFACE OF BUMPER

TARGET AREA FOR ORIGINALLY EQUIPPED PART
: ATTACH THE LABEL, ON INNER SURFACE OF BUMPER
86465-R0300, 1EA (LABEL-VIN)

FR BUMPER ASSY (STD)

Front Bumper (GT-Line)

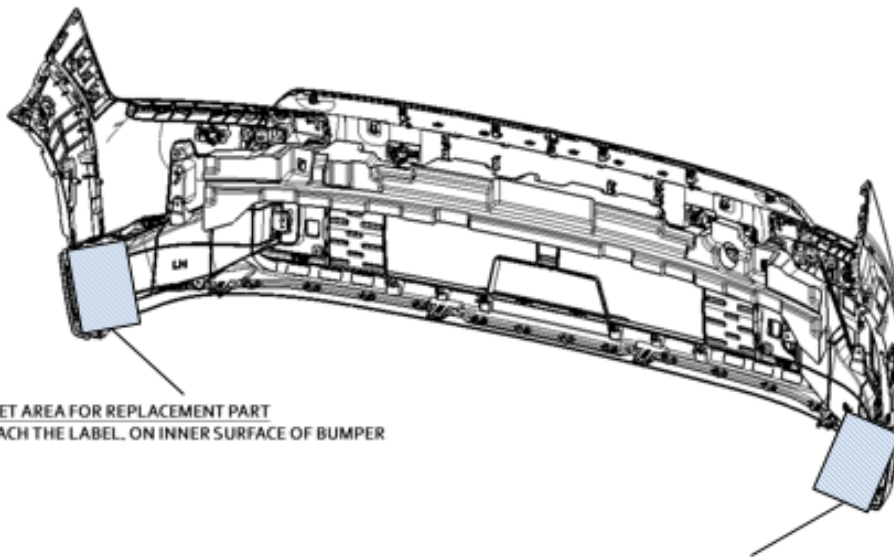
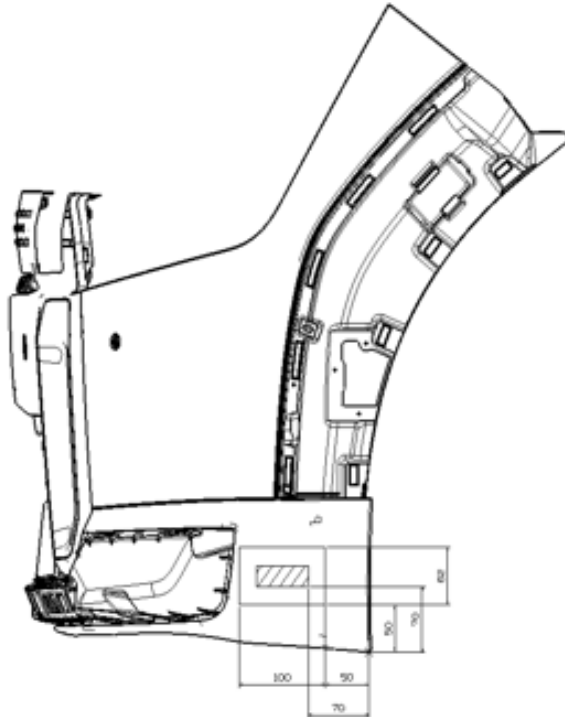

TARGET AREA FOR REPLACEMENT PART
: ATTACH THE LABEL ON INNER SURFACE OF BUMPER

TARGET AREA FOR ORIGINALLY EQUIPPED PART
: ATTACH THE LABEL ON INNER SURFACE OF BUMPER
86465-R0300, 1EA (LABEL-VIN)

FR BUMPER ASSY (GT-LINE)

Rear Bumper (STD)

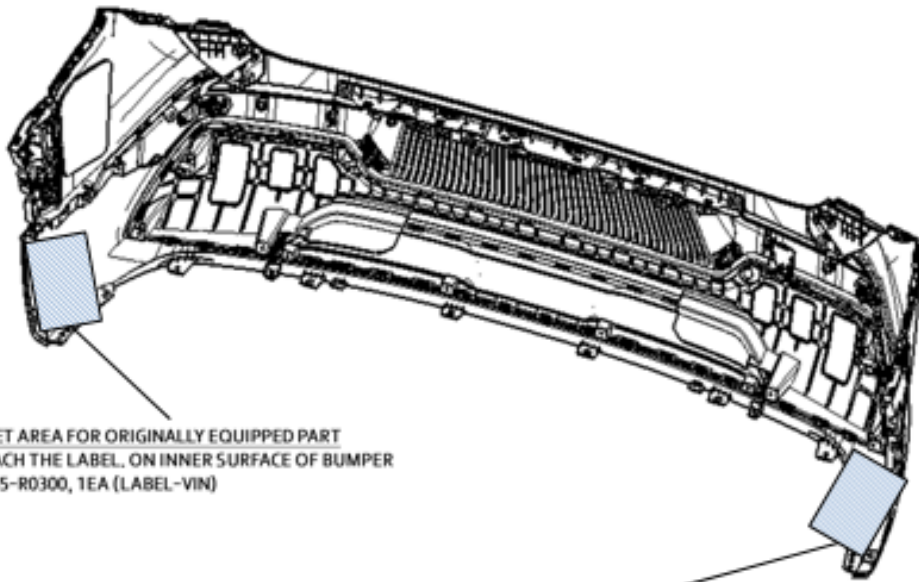
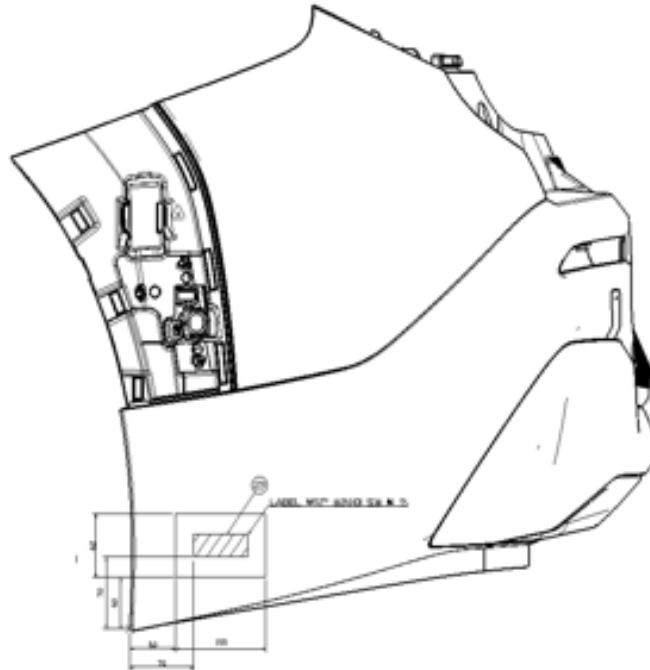

TARGET AREA FOR ORIGINALLY EQUIPPED PART
: ATTACH THE LABEL, ON INNER SURFACE OF BUMPER
86465-R0300, 1EA (LABEL-VIN)

TARGET AREA FOR REPLACEMENT PART
: ATTACH THE LABEL, ON INNER SURFACE OF BUMPER

RR BUMPER ASSY (STD)

Rear Bumper (GT-Line)

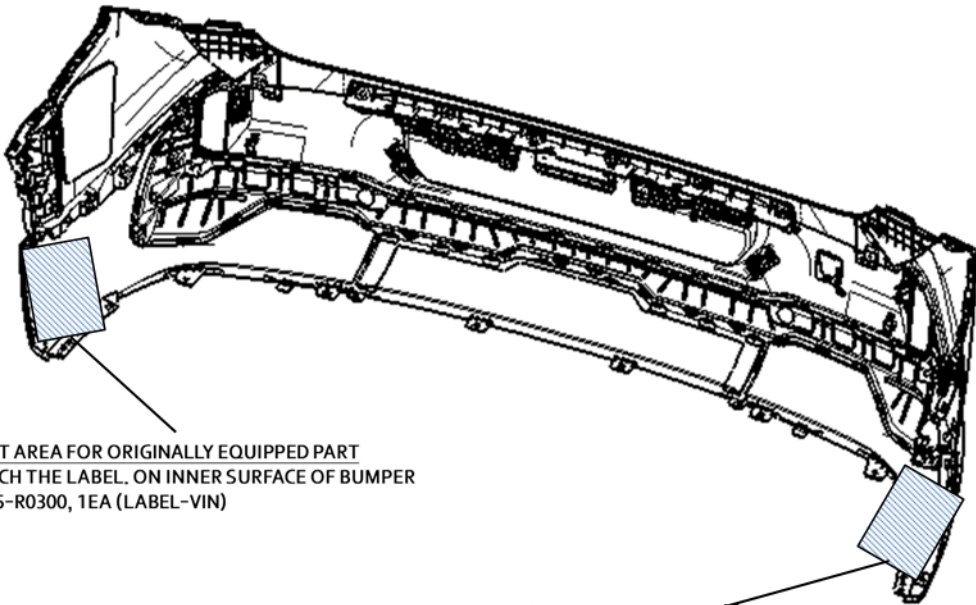
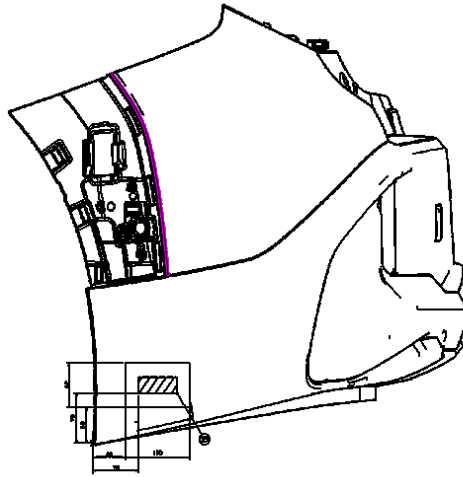

TARGET AREA FOR ORIGINALLY EQUIPPED PART
: ATTACH THE LABEL. ON INNER SURFACE OF BUMPER
86465-R0300, 1EA (LABEL-VIN)

TARGET AREA FOR REPLACEMENT PART
: ATTACH THE LABEL. ON INNER SURFACE OF BUMPER

MV Motor (FR 160 kW)

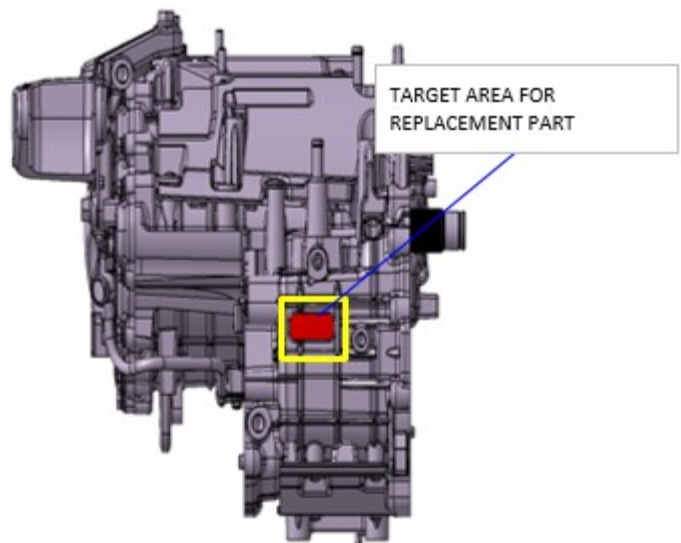

MV Motor (RR 160kW)

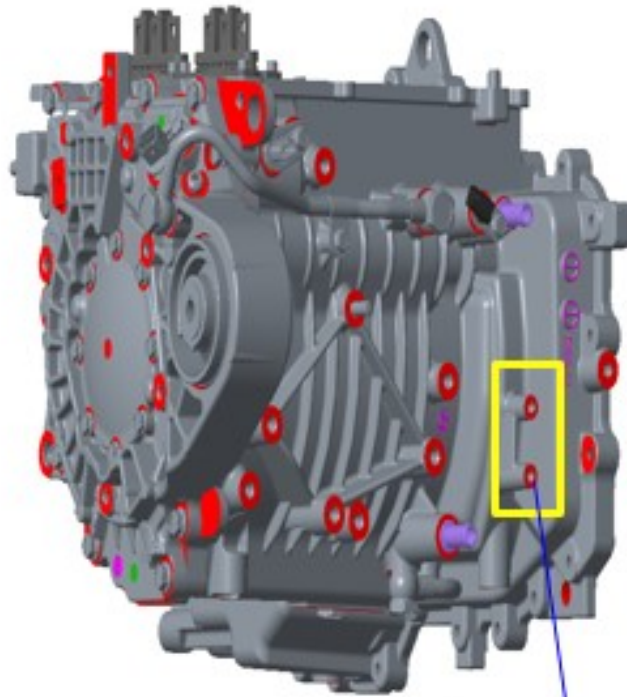

TARGET AREA FOR
ORIGINALLY
EQUIPPED PART

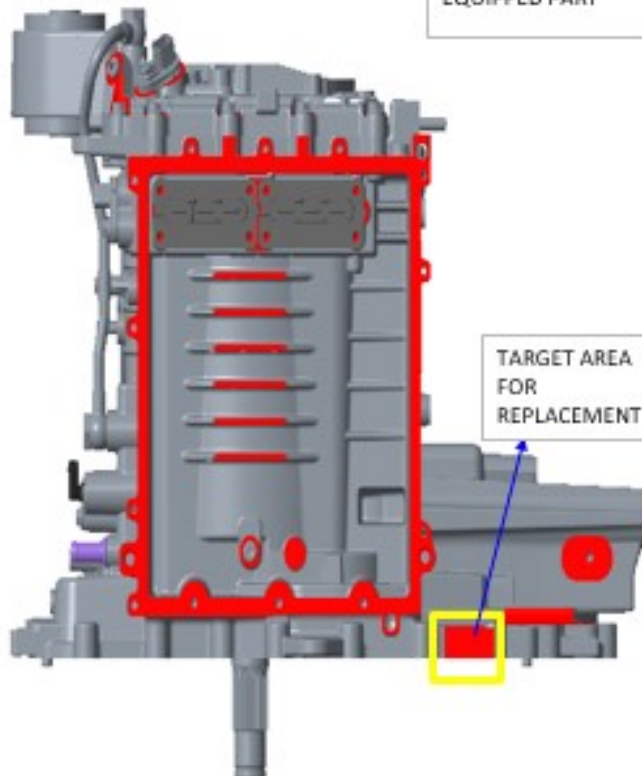

TARGET AREA
FOR
REPLACEMENT