

VIN marking area for Seltos model

- 1. Hood**
- 2. Tail Gate**
- 3. Front Fender (LH/RH)**
- 4. Front Door (LH/RH)**
- 5. Rear Door (LH/RH)**
- 6. Side Outer Panel (LH/RH)**
- 7. Front Bumper**
- 8. Rear Bumper**
- 9. Engine [Nu 2.0 MPI, Gamma-II 1.6 TGDI]**
- 10. Transmission [CVT, 8AT]**

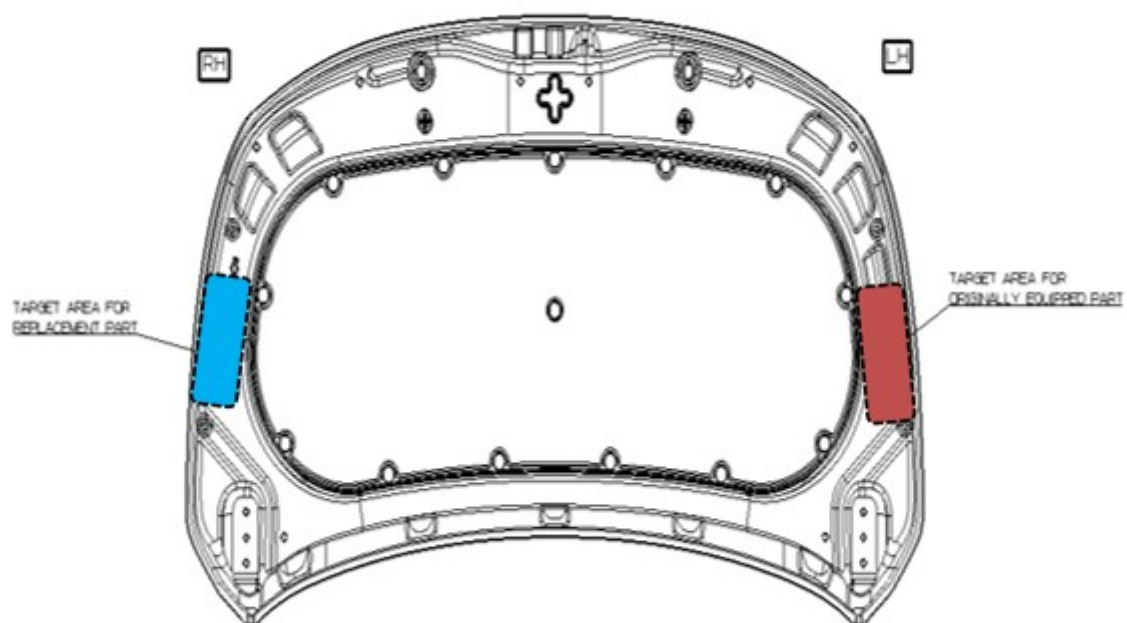

Hood



Tail Gate

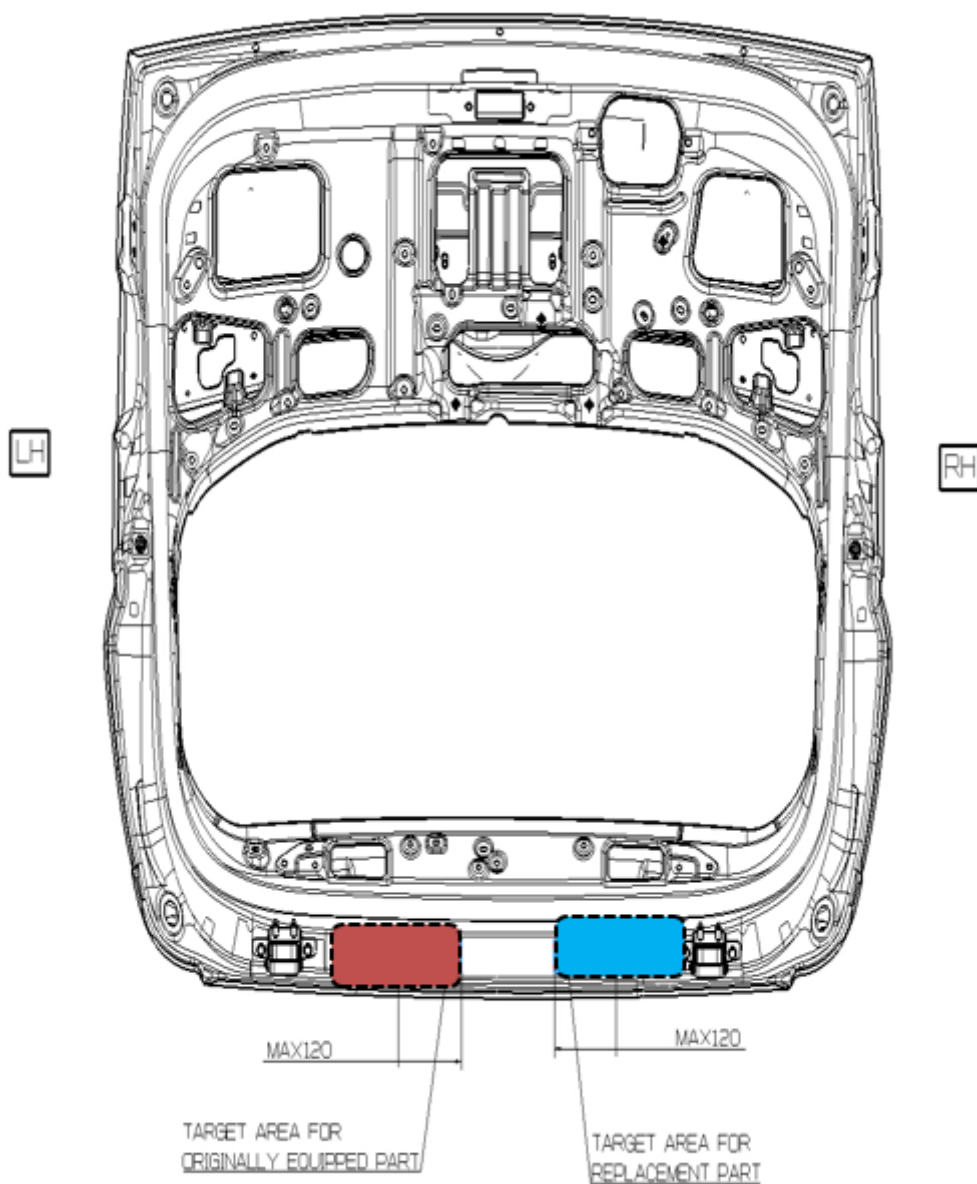

Front Fender (LH/RH)

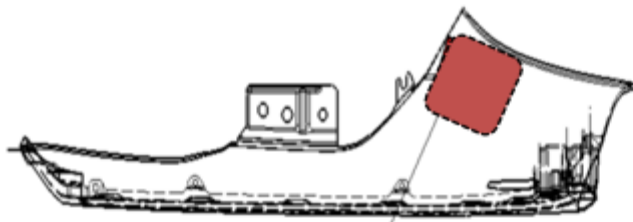

TARGET AREA FOR
ORIGINALLY EQUIPPED PART

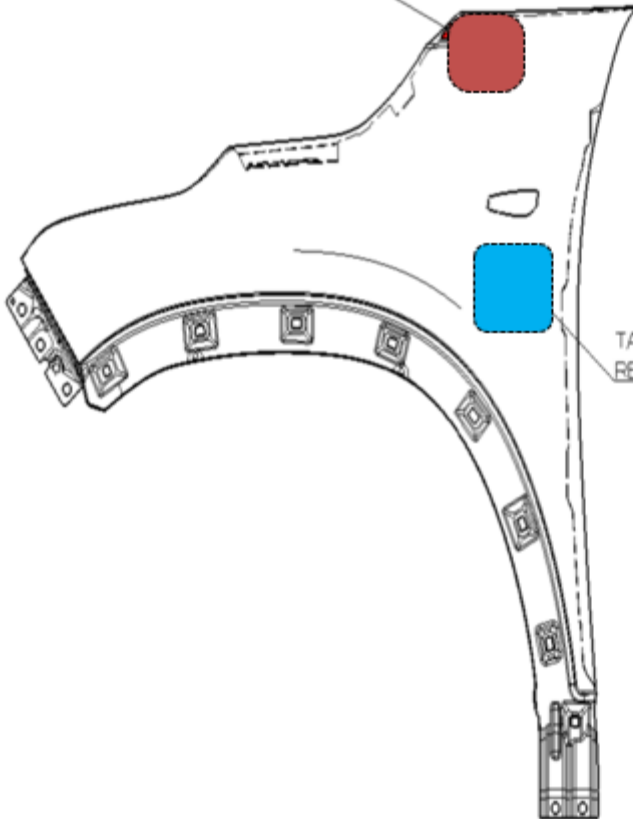

TARGET AREA FOR
REPLACEMENT PART

Front Door (LH/RH)

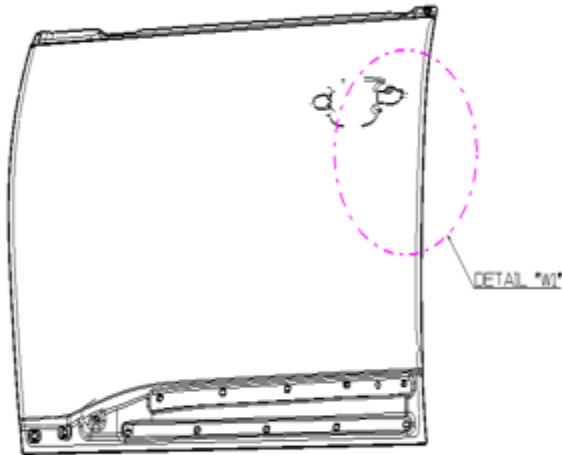

DETAIL "W"

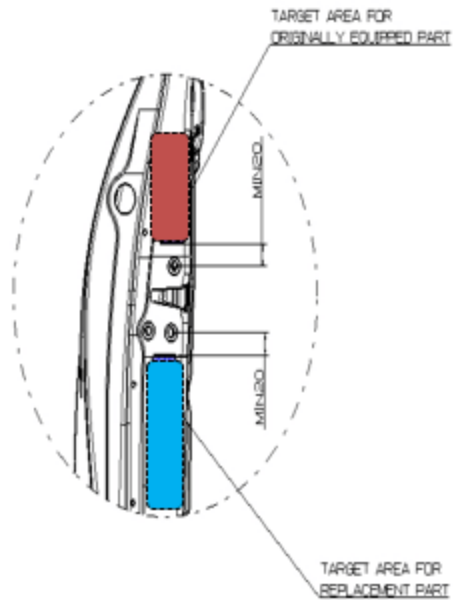

DETAIL "W1"
<APPLY AREA>
-PNL ASSY-FR DR, LH/RH

Rear Door (LH/RH)

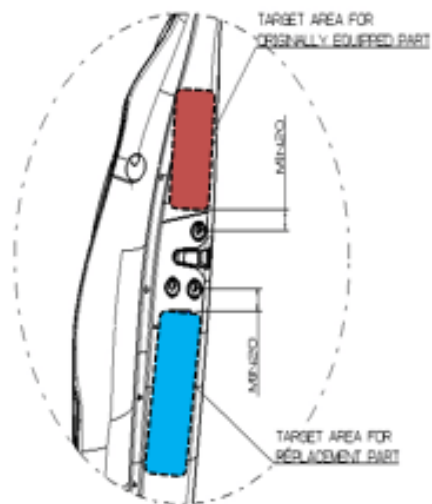
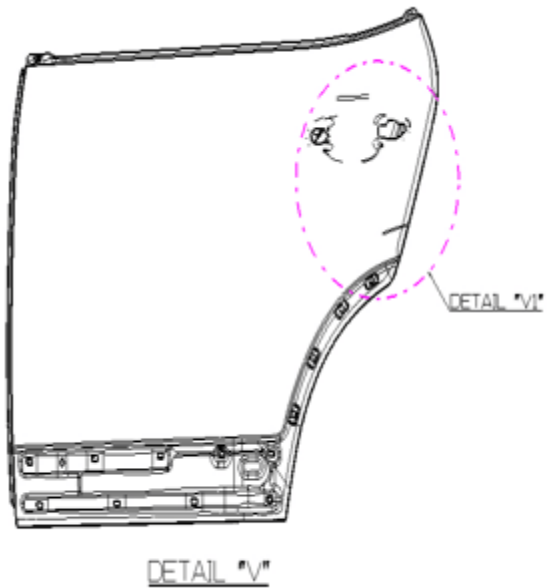

DETAIL "VI"
(APPLY AREA)
-PNL ASSY-RR DR, LH/RH

Side Outer Panel (LH/RH)

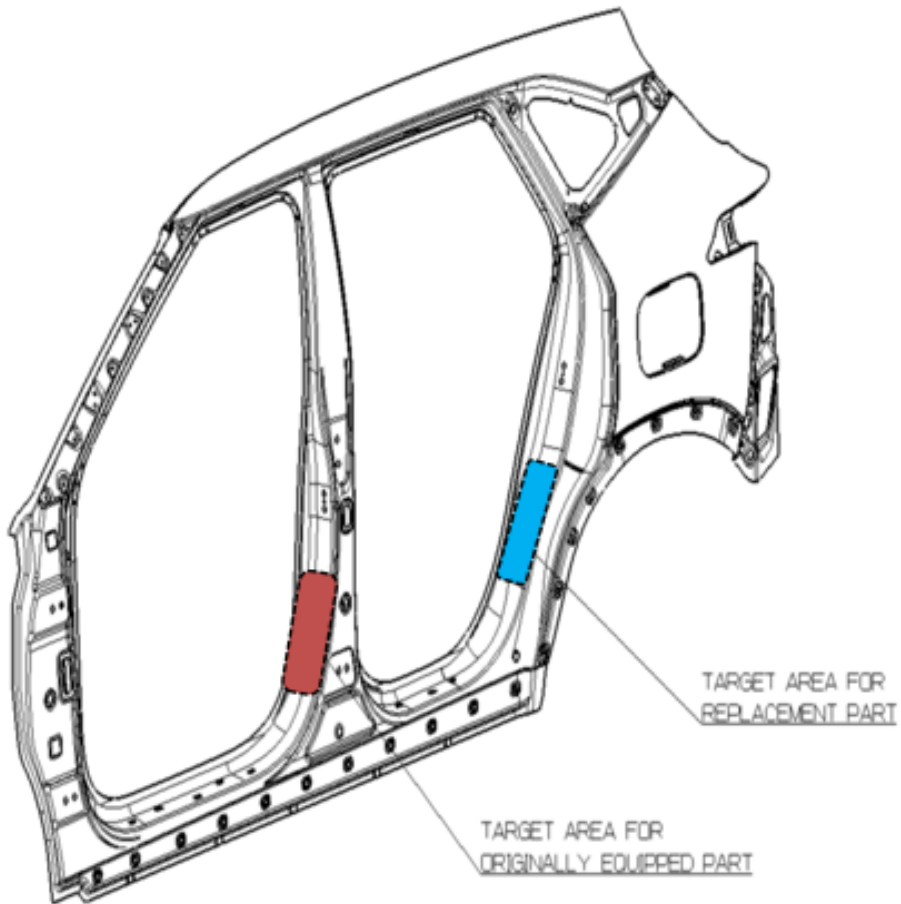

Front Bumper

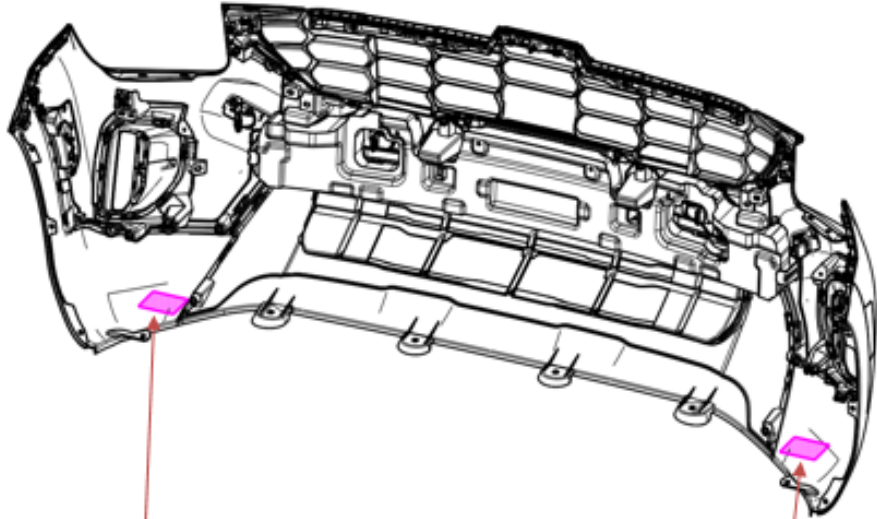

LH Inside
(Original Equipment Part)

RH Inside
(Replacement Part)

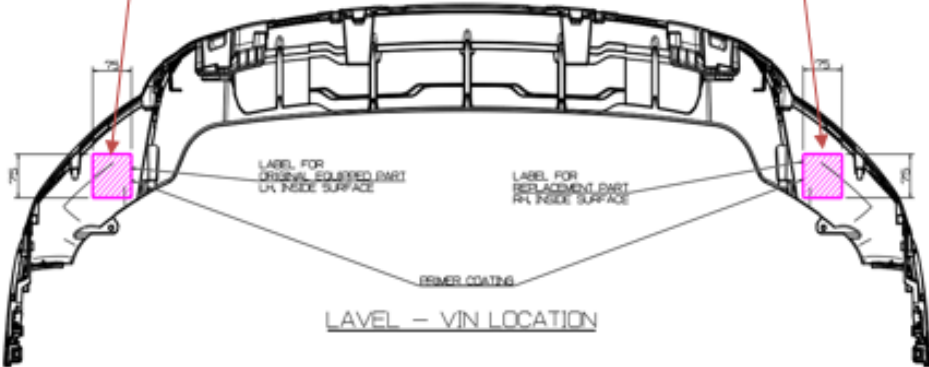

Rear Bumper

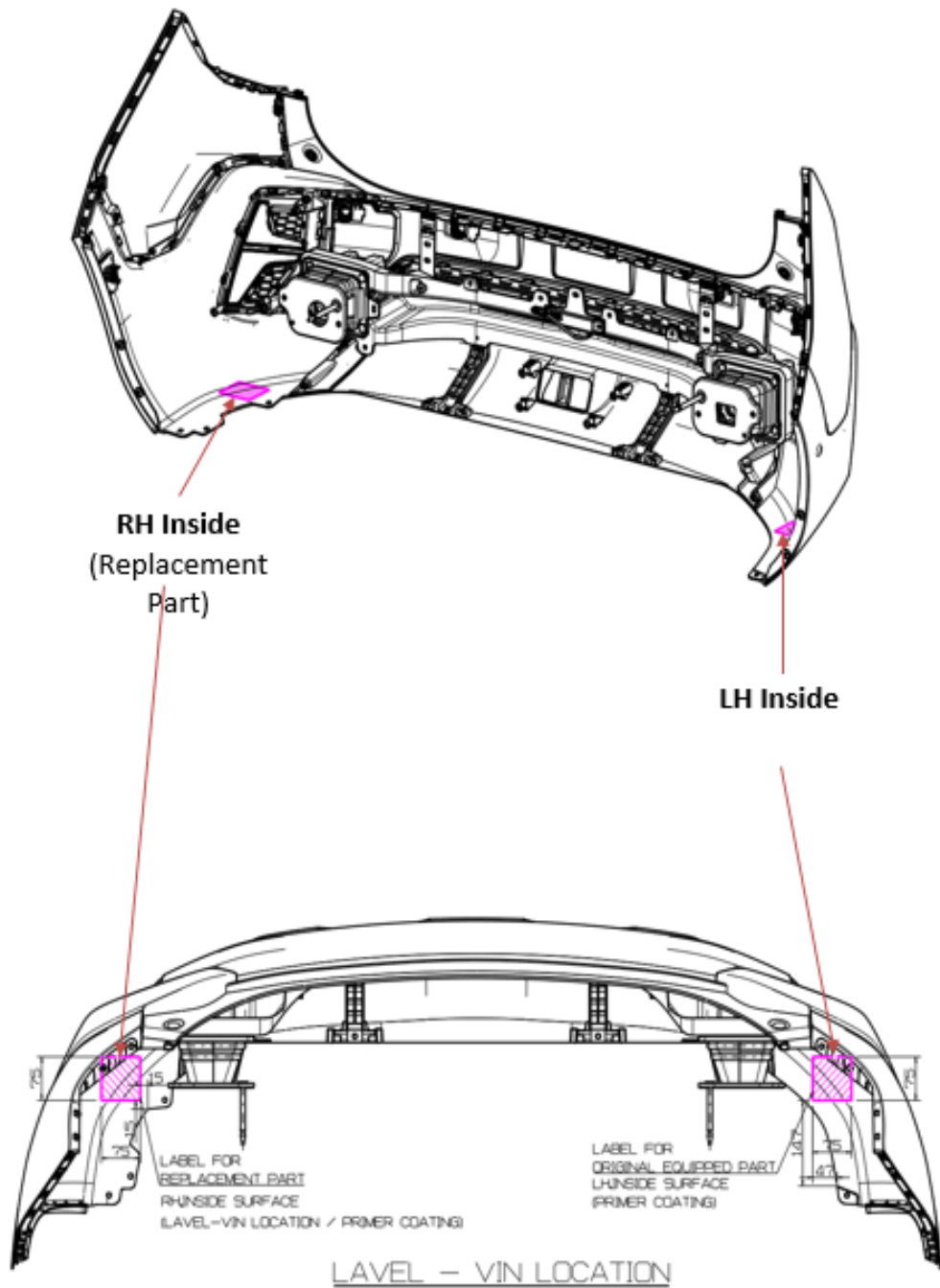

Engine (Nu 2.0 MPI)

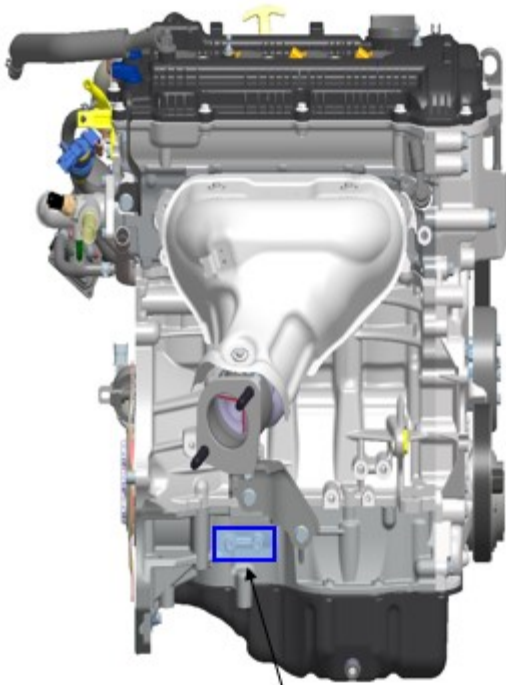

TARGET AREA 'A' FOR
ORIGINALLY EQUIPPED
PART

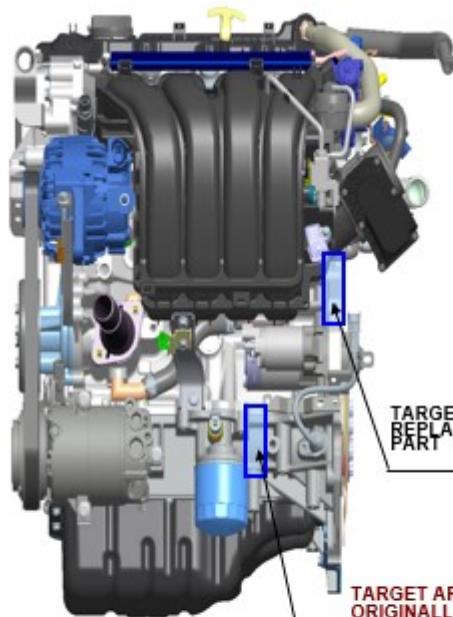

TARGET AREA FOR
REPLACEMENT
PART

TARGET AREA 'B' FOR
ORIGINALLY EQUIPPED
PART
(ALTERNATIVE)

In the case of engine which is originally installed,
VIN label will be attached to a position either 'A' or
'B'.

Engine (Gamma-II 1.6 TGDI)

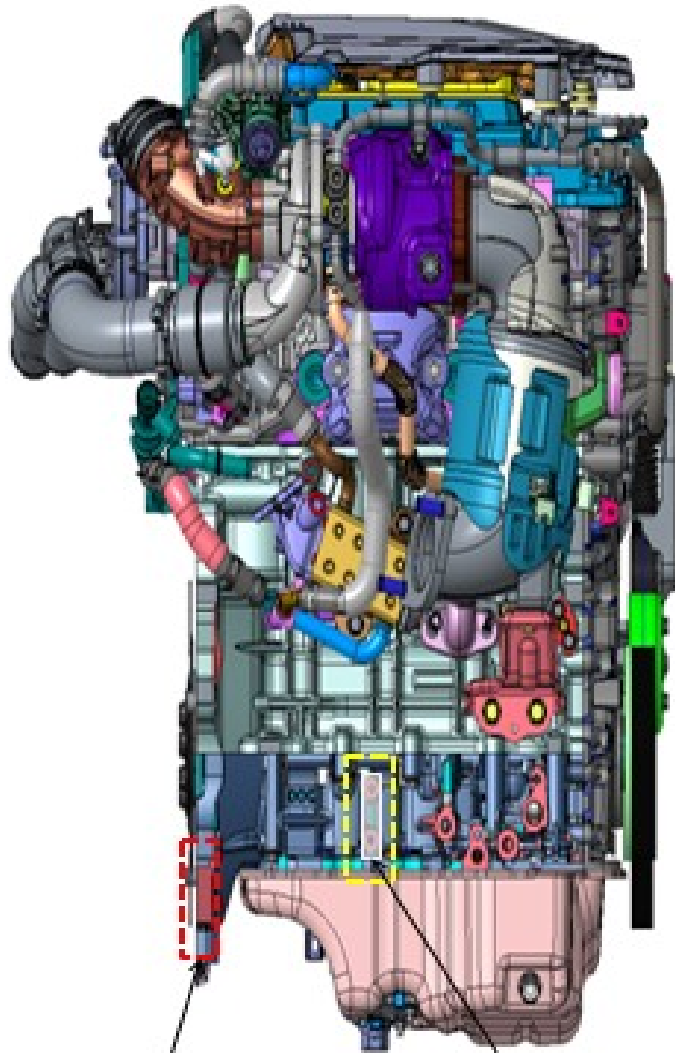

Target area for
replacement
part

Target area (V,I,N)
for original
equipment
part

Transmission (CVT)

TARGET AREA FOR
REPLACEMENT PART

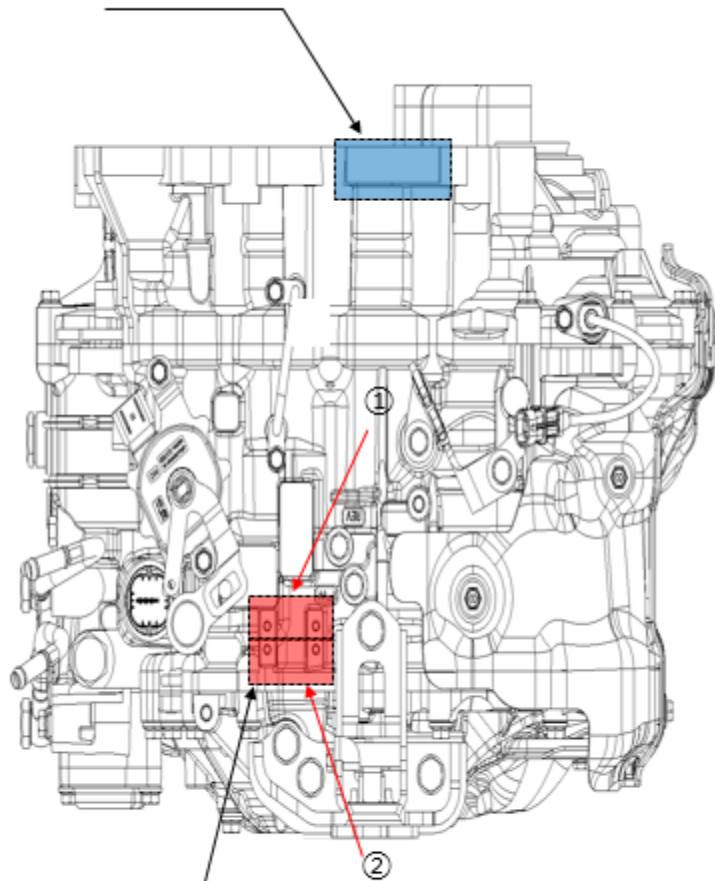

TARGET AREA FOR
ORIGINALLY EQUIPPED PART
(ATTACH ONE VIN PLATE LOCATION 1 OR 2.)

Transmission (8AT)

TARGET AREA FOR
REPLACEMENT PART

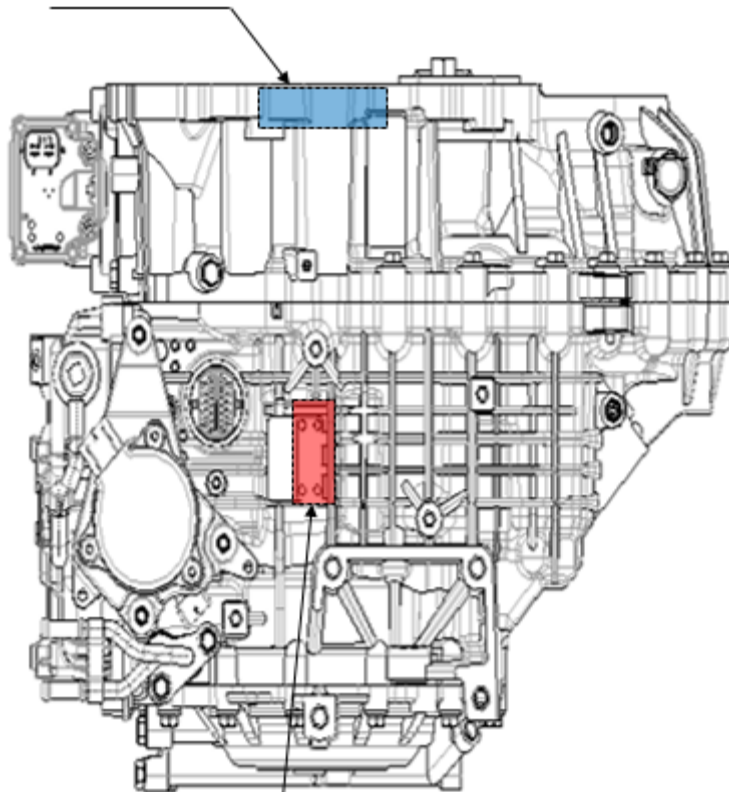

TARGET AREA FOR
ORIGINALLY EQUIPPED PART