

**NEW CAR ASSESSMENT PROGRAM
CRASH IMMINENT BRAKING SYSTEM CONFIRMATION TEST
NCAP-DRI-CIB-22-16**

2022 Toyota RAV4 XLE

DYNAMIC RESEARCH, INC.
355 Van Ness Avenue, STE 200
Torrance, California 90501



1 February 2022

Draft Report

Prepared Under Contract No. DTNH22-14-D-00333

**U.S. DEPARTMENT OF TRANSPORTATION
National Highway Traffic Safety Administration
New Car Assessment Program
1200 New Jersey Avenue, SE
West Building, 4th Floor (NRM-110)
Washington, DC 20590**

Prepared for the Department of Transportation, National Highway Traffic Safety Administration, under Contract No. DTNH22-14-D-00333.

This publication is distributed by the U.S. Department of Transportation, National Highway Traffic Safety Administration, in the interest of information exchange. The opinions, findings, and conclusions expressed in this publication are those of the author(s) and not necessarily those of the Department of Transportation or the National Highway Traffic Safety Administration. The United States Government assumes no liability for its contents or use thereof. If trade or manufacturer's names or products are mentioned, it is only because they are considered essential to the object of the publication and should not be construed as an endorsement. The United States Government does not endorse products of manufacturers.

Prepared By: Stephen Rhim

Senior Staff Engineer

Date: 1 February 2022

John Partridge

Test Engineer

1. Report No. NCAP-DRI-CIB-22-16	2. Government Accession No.	3. Recipient's Catalog No.	
4. Title and Subtitle Draft Report of Crash Imminent Braking System Confirmation Test of a 2022 Toyota RAV4 XLE.		5. Report Date 1 February 2022	
		6. Performing Organization Code DRI	
7. Author(s) Stephen Rhim, Senior Staff Engineer John Partridge, Test Engineer		8. Performing Organization Report No. DRI-TM-21-91	
9. Performing Organization Name and Address Dynamic Research, Inc. 355 Van Ness Ave, STE 200 Torrance, CA 90501		10. Work Unit No.	
		11. Contract or Grant No. DTNH22-14-D-00333	
12. Sponsoring Agency Name and Address U.S. Department of Transportation National Highway Traffic Safety Administration New Car Assessment Program 1200 New Jersey Avenue, SE, West Building, 4th Floor (NRM-110) Washington, DC 20590		13. Type of Report and Period Covered Draft Test Report February 2022	
		14. Sponsoring Agency Code NRM-110	
15. Supplementary Notes			
16. Abstract These tests were conducted on the subject 2022 Toyota RAV4 XLE in accordance with the specifications of the New Car Assessment program's (NCAP's) most current Test Procedure in docket NHTSA-2015-0006-0025; CRASH IMMINENT BRAKE SYSTEM PERFORMANCE EVALUATION FOR THE NEW CAR ASSESSMENT PROGRAM, October 2015. The vehicle passed the requirements of the test for all four CIB test scenarios and all speeds.			
17. Key Words Crash Imminent Braking, CIB, AEB, New Car Assessment Program, NCAP		18. Distribution Statement Copies of this report are available from the following: NHTSA Technical Reference Division National Highway Traffic Safety Administration 1200 New Jersey Avenue, SE Washington, DC 20590	
19. Security Classif. (of this report) Unclassified	20. Security Classif. (of this page) Unclassified	21. No. of Pages 115	22. Price

TABLE OF CONTENTS

<u>SECTION</u>	<u>PAGE</u>
I. INTRODUCTION	1
II. DATA SHEETS.....	2
Data Sheet 1: Test Results Summary	3
Data Sheet 2: Vehicle Data.....	4
Data Sheet 3: Test Conditions	5
Data Sheet 4: Crash Imminent Braking System Operation	7
III. TEST PROCEDURES	10
A. Test Procedure Overview.....	10
B. General Information	15
C. Principal Other Vehicle.....	18
D. Automatic Braking System	19
E. Instrumentation	19
APPENDIX A Photographs.....	A-1
APPENDIX B Excerpts from Owner's Manual	B-1
APPENDIX C Run Log.....	C-1
APPENDIX D Time Histories	D-1

Section I

INTRODUCTION

Crash Imminent Braking (CIB) systems are a subset of Automatic Emergency Braking (AEB) systems. CIB systems are designed to avoid, or mitigate rear-end crashes, by automatically applying subject vehicle brakes when the system determines that, without intervention, a rear-end crash will occur. CIB systems typically work as an extension of Forward Collision Warning (FCW) systems, which alert the driver to the possibility of a collision unless driver action is taken. CIB systems employ sensors capable of detecting vehicles in the forward path. Current CIB technology typically involves RADAR, LIDAR, or vision-based (camera) sensors, and measurement of vehicle operating conditions such as speed, driver steering and brake application, etc. Algorithms in the system's Central Processing Unit (CPU) use this information to continuously monitor the likelihood of a rear-end crash and command a brake actuator to apply the brakes when necessary.

The method prescribed by the National Highway Traffic Safety Administration (NHTSA) to evaluate CIB performance on the test track¹ involves three rear-end type crash configurations and a "false positive" test. In the rear-end scenarios, a subject vehicle (SV) approaches a stopped, slower-moving, or decelerating principal other vehicle (POV) in the same lane of travel. For these tests, the POV is a strikeable object with the characteristics of a compact passenger car. The false positive scenarios are used to evaluate the propensity of a CIB system to inappropriately activate in a non-critical driving scenario that does not involve a forward vehicle or present a safety risk to the SV occupant(s).

The purpose of the testing reported herein was to objectively quantify the performance of a Crash Imminent Braking system installed on a 2022 Toyota RAV4 XLE. This test is part of the New Car Assessment Program to assess Crash Imminent Braking Systems sponsored by the National Highway Traffic Safety Administration under Contract No. DTNH22-14-D-00333.

¹ NHTSA-2015-0006-0025; Crash Imminent Brake System Performance Evaluation for the New Car Assessment Program, October 2015.

Section II
DATA SHEETS

CRASH IMMINENT BRAKING
DATA SHEET 1: TEST RESULTS SUMMARY

(Page 1 of 1)

2022 Toyota RAV4 XLE

VIN: 2T3W1RFV3NC17xxxx

Test start date: 1/27/2022

Test end date: 1/27/2022

Crash Imminent Braking System setting: Early

**Test 1 – Subject Vehicle Encounters
Stopped Principal Other Vehicle**

SV 25 mph: Pass

**Test 2 – Subject Vehicle Encounters
Slower Principal Other Vehicle**

SV 25 mph POV 10 mph: Pass

SV 45 mph POV 20 mph: Pass

**Test 3 – Subject Vehicle Encounters
Decelerating Principal Other Vehicle**

SV 35 mph POV 35 mph: Pass

**Test 4 – Subject Vehicle Encounters
Steel Trench Plate**

SV 25 mph: Pass

SV 45 mph: Pass

Overall: Pass

Notes:

CRASH IMMINENT BRAKING
DATA SHEET 2: VEHICLE DATA

(Page 1 of 1)

2022 Toyota RAV4 XLE

TEST VEHICLE INFORMATION

VIN: 2T3W1RFV3NC17xxxx

Body Style: SUV

Color: White

Date Received: 1/11/2022

Odometer Reading: 226 mi

DATA FROM VEHICLE'S CERTIFICATON LABEL

Vehicle manufactured by: Toyota Motor Manufacturing Canada Inc.

Date of manufacture: 12/21

Vehicle Type: MPV

DATA FROM TIRE PLACARD

Tires size as stated on Tire Placard: Front: 225/65R17

Rear: 225/65R17

Recommended cold tire pressure: Front: 240 kPa (35 psi)

Rear: 240 kPa (35 psi)

TIRES

Tire manufacturer and model: Dunlop Grandtrek PT20

Front tire designation: 225/65R17 102H

Rear tire designation: 225/65R17 102H

Front tire DOT prefix: R8F5 DM9R

Rear tire DOT prefix: R8F5 DM9R

CRASH IMMINENT BRAKING
DATA SHEET 3: TEST CONDITIONS

(Page 1 of 2)

2022 Toyota RAV4 XLE

GENERAL INFORMATION

Test start date: 1/27/2022

Test end date: 1/27/2022

AMBIENT CONDITIONS

Air temperature: 18.9 C (66 F)

Wind speed: 1.0 m/s (2.3 mph)

X Windspeed \leq 10 m/s (22 mph)

X Tests were not performed during periods of inclement weather. This includes, but is not limited to, rain, snow, hail, fog, smoke, or ash.

X Tests were conducted during daylight hours with good atmospheric visibility (defined as an absence of fog and the ability to see clearly for more than 5000 meters). The tests were not conducted with the vehicle oriented into the sun during very low sun angle conditions, where the sun is oriented 15 degrees or less from horizontal, and camera "washout" or system inoperability results.

VEHICLE PREPARATION

Verify the following:

All non-consumable fluids at 100% capacity: X

Fuel tank is full: X

Tire pressures are set to manufacturer's recommended cold tire pressure: X

Front: 240 kPa (35 psi)

Rear: 240 kPa (35 psi)

CRASH IMMINENT BRAKING
DATA SHEET 3: TEST CONDITIONS

(Page 2 of 2)

2022 Toyota RAV4 XLE

WEIGHT

Weight of vehicle as tested including driver and instrumentation

Left Front: 504.8 kg (1113 lb)

Right Front: 526.2 kg (1160 lb)

Left Rear: 367.0 kg (809 lb)

Right Rear: 355.6 kg (784 lb)

Total: 1753.6 kg (3866 lb)

CRASH IMMINENT BRAKING
DATA SHEET 4: CRASH IMMINENT BRAKING SYSTEM OPERATION

(Page 1 of 3)

2022 Toyota RAV4 XLE

Name of the CIB option, option package, etc.:

Toyota Safety Sense 2.0: Pre-Collision System w/ Pedestrian Detection

Type and location of sensors the system uses:

Millimeter wave radar mounted behind the front bumper grill and a mono camera in the top center of the windshield.

System setting used for test (if applicable):

Early

Over what speed range is the system operational?

The AEB system is operational between 10-180 km/h (7-110 mph) per manufacturer supplied information.

Does the vehicle system require an initialization sequence/procedure? Yes
 No

If yes, please provide a full description.

Sensor calibration is required. The vehicle should be driven for a combined distance (does not have to be continuous) of at least 1 km at a minimum speed of 35 mph on a road with lane markings on both sides.

Will the system deactivate due to repeated CIB activations, impacts, or near-misses? Yes
 No

If yes, please provide a full description.

How is the Forward Collision Warning system alert presented to the driver? Warning light
(Check all that apply) Buzzer or auditory alarm
 Vibration
 Other

CRASH IMMINENT BRAKING

DATA SHEET 4: CRASH IMMINENT BRAKING SYSTEM OPERATION

(Page 2 of 3)

2022 Toyota RAV4 XLE

Describe the method by which the driver is alerted. For example, if the warning is a light, where is it located, its color, size, words, or symbol, does it flash on and off, etc. If it is a sound, describe if it is a constant beep or a repeated beep. If it is a vibration, describe where it is felt (e.g., pedals, steering wheel), the dominant frequency (and possibly magnitude), the type of warning (light, auditory, vibration, or combination), etc.

The AEB system alerts the driver with a visual and auditory alert. The visual alert is displayed in the multi-information display located in the center of the instrument panel and consists of a red box and the word "BRAKE!". The auditory alert consists of repeated beeps with a primary frequency of approximately 2400 Hz.

Is there a way to deactivate the system?

 X Yes
 No

If yes, please provide a full description including the switch location and method of operation, any associated instrument panel indicator, etc.

The AEB system (referred to as the Pre-Collision System (PCS) in the owner's manual pages 227-230 shown in Appendix B pages B-2 to B-5) can be turned on/off using the buttons on the left side of the steering wheel. The procedure is as follows:

1. Press the < > button until the gear icon is selected in the multi-information display.
2. Scroll down until "PCS" is outlined and hold the "OK" button to select.
3. Within the PCS menu, scroll down to "PCS" and press "OK" to turn the AEB system on/off.

When the AEB system is turned off, the PCS warning light illuminates, and a message is displayed in the multi-information display. The system is automatically enabled each time the engine switch is turned on.

Section III

TEST PROCEDURES

A. Test Procedure Overview

Four test scenarios were used, as follows:

Test 1. Subject Vehicle (SV) Encounters Stopped Principal Other Vehicle (POV)

Test 2. Subject Vehicle Encounters Slower Principal Other Vehicle

Test 3. Subject Vehicle Encounters Decelerating Principal Other Vehicle

Test 4. Subject Vehicle Encounters Steel Trench Plate

An overview of each of the test procedures follows.

1. TEST 1 – SUBJECT VEHICLE ENCOUNTERS STOPPED PRINCIPAL OTHER VEHICLE ON A STRAIGHT ROAD

This test evaluates the ability of the CIB system to detect and respond to a stopped lead vehicle in the immediate forward path of the SV, as depicted in Figure 1.

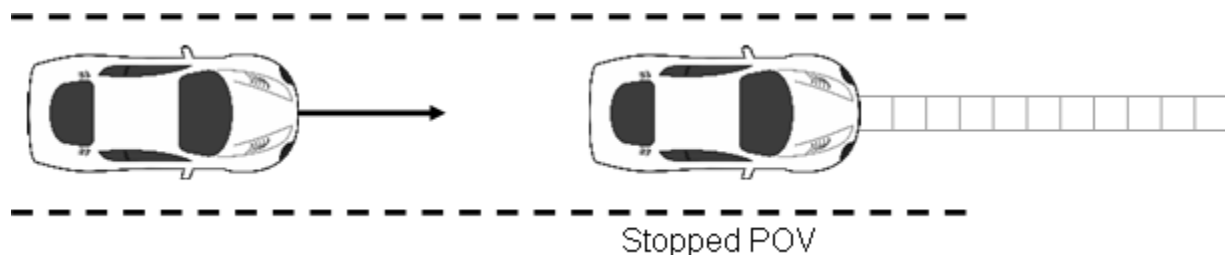

Figure 1. Depiction of Test 1

a. Procedure

The POV was parked in the center of a travel lane, with its longitudinal axis oriented parallel to the roadway edge and facing the same direction as the SV so that the SV approached the rear of the POV.

The SV ignition was cycled prior to each test run. The SV was driven at a nominal speed of 25 mph (40.2 km/h) in the center of the lane of travel, toward the parked POV. The SV throttle pedal was released within 500 ms after t_{FCW} , i.e. within 500 ms of the FCW alert. The test concluded when either:

- The SV came into contact with the POV or
- The SV came to a stop before making contact with the POV.

In addition to the general test validity criteria described below, for an individual test trial to be valid, the following was required throughout the test:

- The lateral distance between the centerline of the SV to the center of the travel lane could not deviate more than ± 1 ft (0.3 m) during the validity period.
- The yaw rate of the SV could not deviate more than ± 1 deg/sec during the validity period.
- The SV speed could not deviate from the nominal speed by more than ± 1.0 mph (± 1.6 km/h) during an interval defined by a Time to Collision (TTC) = 5.1 seconds to t_{FCW} or impact if no FCW alert was given.

b. Criteria

In order to pass the test, the magnitude of the SV speed reduction attributable to CIB intervention must have been ≥ 9.8 mph (15.8 km/h) for at least five of seven valid test trials.

The magnitude of the SV speed reduction attributable to CIB intervention was calculated in one of two ways, depending on whether a test trial concluded with the SV colliding with the POV.

- If SV-to-POV contact occurred during a test trial, the CIB speed reduction was calculated by subtracting the SV speed at the time of SV-to-POV contact (i.e., when longitudinal range became zero) from the average SV speed calculated from $t_{FCW} - 100$ ms to t_{FCW} .
- If SV-to-POV contact did not occur during a test trial (i.e., CIB intervention prevented the crash), the SV speed at a time of SV-to-POV contact was taken to be zero. The speed reduction is therefore equal to the SV speed at t_{FCW} .

2. TEST 2 – SUBJECT VEHICLE ENCOUNTERS SLOWER PRINCIPAL OTHER VEHICLE

- This test evaluates the ability of the CIB system to detect and respond to a slower-moving lead vehicle traveling at a constant speed in the immediate forward path of the SV, as depicted in Figure 2.

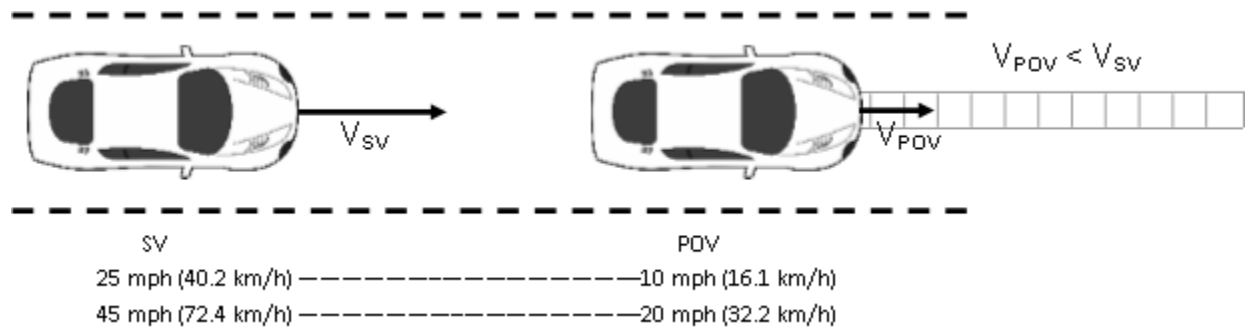

Figure 2. Depiction of Test 2

a. Procedure

The SV ignition was cycled prior to each test run. The tests were conducted two ways. In the first, the POV was driven at a constant 10.0 mph (16.1 km/h) in the center of the lane of travel while the SV was driven at 25.0 mph (40.2 km/h), in the center lane of travel, toward the slower-moving POV. In the second, the POV was driven at a constant 20.0 mph (32.2 km/h) in the center of the lane of travel while the SV was driven at 45.0 mph (72.4 km/h), in the center lane of travel, toward the slower-moving POV. In both cases, the SV throttle pedal was released within 500 ms after t_{FCW} , i.e. within 500 ms of the FCW alert. The test concluded when either:

- The SV came into contact with the POV or
- 1 second after the speed of the SV becomes less than or equal to that of the POV.

The SV driver then braked to a stop.

In addition to the general test validity criteria described below, for an individual test trial to be valid, the following was required throughout the test:

- The lateral distance between the centerline of the SV and POV to the center of the travel lane could not deviate more than ± 1 ft (0.3 m) during the validity period.
- The yaw rate of the SV and POV could not deviate more than ± 1 deg/sec during the validity period.
- The SV speed could not deviate more than ± 1.0 mph (± 1.6 km/h) during an interval defined by $TTC = 5.0$ seconds to t_{FCW} or impact if no FCW alert was given.
- The POV speed could not deviate more than ± 1.0 mph (± 1.6 km/h) during the validity period.

b. Criteria

For the test series in which the initial SV speed was 25 mph, the condition for passing was that there be no SV-to-POV impact for at least five of the seven valid test trials.

In order to pass the test series for which the initial speed of the SV was 45 mph, the magnitude of the SV speed reduction attributable to CIB intervention must have been ≥ 9.8 mph (15.8 km/h) for at least five of seven valid test trials. The magnitude of the SV speed reduction attributable to CIB intervention was calculated in one of two ways, depending on whether a test trial concluded with the SV colliding with the POV.

- If SV-to-POV contact occurred during a test trial, the CIB speed reduction was calculated by subtracting the SV speed at the time of SV-to-POV contact (i.e., when longitudinal range became zero) from the average SV speed calculated from $t_{FCW} - 100$ ms to t_{FCW} .
- If SV-to-POV contact did not occur during a test trial (i.e., CIB intervention prevented the crash), the CIB speed reduction was calculated by subtracting the SV speed at the minimum longitudinal SV-to-POV range during the validity period from the SV speed at t_{FCW} .

3. TEST 3 – SUBJECT VEHICLE ENCOUNTERS DECELERATING PRINCIPAL OTHER VEHICLE

This test evaluates the ability of the CIB system to detect and respond to a lead vehicle slowing with a constant deceleration in the immediate forward path of the SV, as depicted in Figure 3.

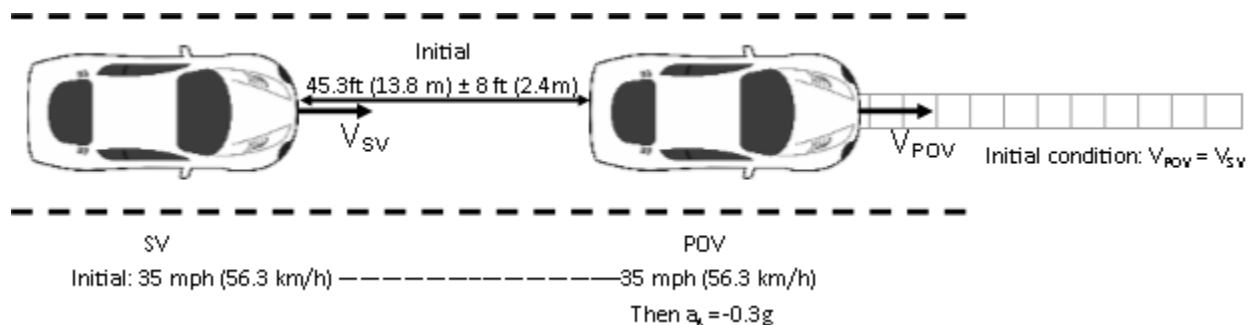

Figure 3. Depiction of Test 3

a. Procedure

The SV ignition was cycled prior to each test run. For this test scenario, both the POV and SV were driven at a constant 35.0 mph (56.3 km/h) in the center of the lane, with a headway of 45.3 ft (13.8 m) \pm 8 ft (2.4 m). Once these conditions were met, the POV tow vehicle brakes were applied to achieve 0.3 ± 0.03 g of deceleration within 1.5 ± 0.1 sec. The test concluded when either:

- The SV came into contact with the POV or
- 1 second after minimum longitudinal SV-to-POV distance has occurred.

The SV driver then braked to a stop.

In addition to the general test validity criteria described below, for an individual test trial to be valid, the following was required throughout the test:

- The lateral distance between the centerline of the SV and POV to the center of the travel lane could not deviate more than ± 1 ft (0.3 m) during the validity period.
- The yaw rate of the SV and POV could not deviate more than ± 1 deg/sec during the validity period.
- The SV speed could not deviate more than ± 1.0 mph (1.6 km/h) during an interval defined by 3.0 seconds before the onset of POV braking to t_{FCW} or impact if no FCW alert was given.
- The POV speed could not deviate more than ± 1.0 mph (1.6 km/h) during an interval of 3.0 seconds before the onset of POV braking.
- The SV- POV headway distance could not deviate more than ± 8 ft (2.4 m) during an interval defined by the onset of the validity period to the onset of POV braking.
- The average POV deceleration could not deviate by more than ± 0.03 g from the nominal 0.3 g deceleration during the interval beginning at 1.5 seconds after the onset of POV braking and ending either 250 ms prior to the POV coming to a stop or the SV coming into contact with the POV.

b. Criteria

In order to pass the decelerating POV test series, the magnitude of the SV speed reduction attributable to CIB intervention must have been ≥ 10.5 mph (16.9 km/h) for at least five of seven valid test trials. The magnitude of the SV speed reduction attributable to CIB intervention was calculated in one of two ways, depending on whether a test trial concluded with the SV colliding with the POV.

- If SV-to-POV contact occurred during a test trial, the CIB speed reduction was calculated by subtracting the SV speed at the time of SV-to-POV contact (i.e., when longitudinal range becomes zero) from the average SV speed calculated from $t_{FCW} - 100$ ms to t_{FCW} .
- If SV-to-POV contact did not occur during a test trial (i.e., CIB intervention prevents the crash), the CIB speed reduction was calculated by subtracting the SV speed at the minimum longitudinal SV-to-POV range during the applicable validity period from the SV speed at t_{FCW} .

4. TEST 4 – FALSE POSITIVE SUPPRESSION

The false positive suppression test series evaluates the ability of a CIB system to differentiate a steel trench plate (STP) from an object presenting a genuine safety risk to the SV. Although the STP is large and metallic, it is designed to be driven over without risk of injury to the driver or damage to the SV. Therefore, in this scenario, the automatic braking available from CIB is not necessary and should be suppressed. The test condition is nearly equivalent to that previously defined for Test 1, the stopped POV condition, but

with an STP in the SV forward path in lieu of a POV.

a. Procedure

This test was conducted at two speeds, 25 mph (40.2 km/h) and 45 mph (72.4 km/h). The SV was driven directly towards, and over, the STP, which was positioned in the center of a travel lane, with its longest sides parallel to the road edge.

In addition to the general test validity criteria described below, for an individual test trial to be valid, the following was required throughout the test:

- The lateral distance between the centerline of the SV to the center of the travel lane could not deviate more than ± 1 ft (0.3 m) during the validity period.
- The yaw rate of the SV could not deviate more than ± 1 deg/sec during the validity period.
- The SV speed could not deviate from the nominal speed by more than 1.0 mph (1.6 km/h) during an interval defined by a Time to Collision (TTC) = 5.1 seconds to t_{FCW} where:
 - For SV test speed of 25 mph, TTC = 5.1 seconds is taken to occur at an SV-to-STP distance of 187 ft (57 m).
 - For SV test speed of 45 mph, TTC = 5.1 seconds is taken to occur at an SV-to-STP distance of 337 ft (106 m).
- If the SV did not present an FCW alert before the end of the validity period, SV speed could not deviate more than ± 1.0 mph (± 1.6 km/h) from TTC = 5.1 s to the end of the validity period.

If an FCW alert was presented, the driver released the throttle pedal within 500 ms of the alert. If no alert was presented, the driver did not release the throttle pedal until the end of the validity period. The SV driver then braked to a stop.

b. Criteria

In order to pass the False Positive test series, the magnitude of the SV deceleration reduction attributable to CIB intervention must have been ≤ 0.50 g for at least five of seven valid test trials.

B. General Information

1. T_{FCW}

The time at which the Forward Collision Warning (FCW) activation flag indicates that the system has issued an alert to the SV driver is designated as t_{FCW} . FCW alerts are typically either visual, haptic or auditory, and the onset of the alert was determined by post-processing the test data.

For systems that implement auditory or haptic alerts, part of the pre-test instrumentation verification process was to determine the tonal frequency of the auditory warning or the vibration frequency of the tactile warning through use of the PSD (Power Spectral Density) function in Matlab. This was accomplished in order to identify the center frequency around which a band-pass filter was applied to subsequent auditory or tactile warning data so that the beginning of such warnings can be programmatically determined. The band-pass filter used for these warning signal types was a phaseless, forward-reverse pass, elliptical (Cauer) digital filter, with filter parameters as listed in Table 1.

Table 1. Auditory and Tactile Warning Filter Parameters

Warning Type	Filter Order	Peak-to-Peak Ripple	Minimum Stop Band Attenuation	Passband Frequency Range
Auditory	5 th	3 dB	60 dB	Identified Center Frequency \pm 5%
Tactile	5 th	3 dB	60 dB	Identified Center Frequency \pm 20%

2. GENERAL VALIDITY CRITERIA

In addition to any validity criteria described above for the individual test scenarios, for an individual trial to be valid, it must have met the following criteria throughout the test:

- The SV driver seatbelt was latched.
- If any load had been placed on the SV front passenger seat (e.g., for instrumentation), the vehicle's front passenger seatbelt was latched.
- The SV was driven at the nominal speed in the center of the travel lane, toward the POV or STP.
- The driver used the least amount of steering input necessary to maintain SV position in the center of the travel lane during the validity period; use of abrupt steering inputs or corrections was avoided.
- The yaw rate of the SV did not exceed ± 1.0 deg/s from the onset of the validity period to the instant SV deceleration exceeded 0.25 g.
- The SV driver did not apply any force to the brake pedal during the applicable validity period.
- The lateral distance between the centerline of the SV and the centerline of the POV or STP did not deviate more than ± 1 ft (0.3 m) during the applicable validity period.

3. VALIDITY PERIOD

The valid test interval began:

Test 1: When the SV-to-POV TTC = 5.1 seconds

Test 2: When the SV-to-POV TTC = 5.0 seconds

Test 3: 3 seconds before the onset of POV braking

Test 4: When the SV-to-STP TTC = 5.1 seconds

The valid test interval ended:

Test 1: When either of the following occurred:

- The SV came into contact with the POV (SV-to-POV contact was assessed by using GPS-based range data or by measurement of direct contact sensor output); or
- The SV came to a stop before making contact with the POV.

Tests 2 and 3: When either of the following occurred:

- The SV came into contact with the POV; or
- 1 second after minimum longitudinal SV-to-POV distance occurred.

Test 4: At the instant the front-most part of SV reached a vertical plane defined by the leading edge of the STP first encountered by the SV (i.e., just before it was driven onto the STP).

4. STATIC INSTRUMENTATION CALIBRATION

To assist in resolving uncertain test data, static calibration data was collected prior to, and immediately after each of the test series.

For Tests 1, 2, and 3, the SV, POV, POV moving platform, and tow vehicle were centered in the same travel lane with the same orientation (i.e., facing the same direction). For Test 4, the SV and STP were centered in the same travel lane.

For Tests 1, 2, and 3, the SV was positioned such that it just contacted a vertical plane that defines the rearmost location of the POV. For Test 4, the front-most location of the SV was positioned such that it just reached a vertical plane defined by the leading edge of the STP first encountered by the SV (i.e., just before it is driven onto the STP). This is the “zero position.”

If the zero position reported by the data acquisition system was found to differ by more

than ± 2 in (± 5 cm) from that measured during collection of the pre-test static calibration data file, the pre-test offset was adjusted to output zero, another pre-test static calibration data file was collected, and the test series was repeated.

5. NUMBER OF TRIALS

A target total of seven (7) valid trials were performed for each scenario. In cases where the test driver performed more than seven trials, the first seven trials satisfying all test tolerances were used to assess the SV performance.

6. TRANSMISSION

All trials were performed with SV automatic transmissions in “Drive” or with manual transmissions in the highest gear capable of sustaining the desired test speed. Manual transmission clutches remained engaged during all maneuvers. The brake lights of the POV were not illuminated.

C. Principal Other Vehicle

CIB testing requires a POV that realistically represents typical vehicles, does not suffer damage or cause damage to a test vehicle in the event of collision, and can be accurately positioned and moved during the tests. The tests reported herein made use of the NHTSA developed Strikeable Surrogate Vehicle (SSV).

This SSV system was designed specifically for common rear-end crash scenarios which AEB systems address. The key components of the SSV system are:

- A POV shell which is a visually and dimensionally accurate representation of a passenger car.
- A slider and load frame assembly to which the shell is attached.
- A two-rail track on which the slider operates.
- A road-based lateral restraint track.
- A tow vehicle.

The key requirements of the POV element are to:

- Provide an accurate representation of a real vehicle to CIB sensors, including cameras and radar.
- Be resistant to damage and inflict little or no damage to the SV as a result of repeated SV-to-POV impacts.

The key requirements of the POV delivery system are to:

- Accurately control the nominal POV speed up to 35 mph (56 km/h).
- Accurately control the lateral position of the POV within the travel lane.

- Allow the POV to move away from the SV after an impact occurs.

Operationally, the POV shell is attached to the slider and load frame which includes rollers that allows the entire assembly to move longitudinally along the guide rail. The guide rail is coupled to a tow vehicle and guided by the lateral restraint track secured to the test track surface. The rail includes a provision for restraining the shell and roller assembly in the ward direction. In operation, the shell and roller assembly engage the rail assembly through detents to prevent relative motion during run-up to test speeds and deceleration of the tow vehicle. The combination of rearward stops and forward motion detents allows the test conditions, such as relative SV-to-POV headway distance, speed, etc., to be achieved and adjusted as needed in the preliminary part of a test. If during the test, the SV strikes the rear of the POV shell, the detents are overcome and the entire shell/roller assembly moves forward in a two-stage manner along the rail and away from the SV. The forward end of the rail has a cushioned stop to restrain forward motion of the shell/roller assembly. After impacting the SSV, the SV driver uses the steering wheel to maintain SV position in the center of the travel lane, thereby straddling the two-rail track. The SV driver must manually apply the SV brakes after impact. The SSV system is shown in Figures A6 through A8 and a detailed description can be found in the NHTSA report: NHTSA'S STRIKEABLE SURROGATE VEHICLE PRELIMINARY DESIGN+OVERVIEW, May 2013.

D. Automatic Braking System

The POV was equipped with an automatic braking system, which was used in Test 3. The braking system consisted of the following components:

- Electronically controlled linear actuator, mounted on the seat rail and attached to the brake pedal. The actuator can be programmed for control of stroke and rate.
- PC module programmed for control of the stroke and rate of the linear actuator.
- Switch to activate actuator.

In some cases, the SV is also equipped with an automatic braking system (E-brake) for the purpose of slowing the SV before impact with the SSV in cases where the SV is likely to fail a test. The system fires when TTC is below 0.7 sec. It is typically enabled when an SV has already impacted the SSV one or two times.

E. Instrumentation

Table 2 lists the sensors, signal conditioning, and data acquisition equipment used for these tests.

Table 2. Test Instrumentation and Equipment

Type	Output	Range	Accuracy, Other Primary Specs	Mfr, Model	Serial Number	Calibration Dates Last Due
Tire Pressure Gauge	Vehicle Tire Pressure	0-100 psi 0-690 kPa	< 1% error between 20 and 100 psi	Omega DPG8001	17042707002	By: DRI Date: 10/5/2021 Due: 10/5/2022
Platform Scales	Vehicle Total, Wheel, and Axle Load	2200 lb/platform	0.1% of reading	Intercomp SW wireless	0410MN20001	By: DRI Date: 2/10/2021 Due: 2/10/2022
Linear (string) encoder	Throttle pedal travel	10 in	0.1 in	UniMeasure LX-EP	50060726	By: DRI Date: 4/15/2021 Due: 4/15/2022
Differential Global Positioning System	Position, Velocity	Latitude: ± 90 deg Longitude: ± 180 deg Altitude: 0-18 km Velocity: 0-1000 knots	Horizontal Position: ± 1 cm Vertical Position: ± 2 cm Velocity: 0.05 km/h	Trimble GPS Receiver, 5700 (base station and in-vehicle)	00440100989	N/A
Multi-Axis Inertial Sensing System	Position; Longitudinal, Lateral, and Vertical Accels; Lateral, Longitudinal and Vertical Velocities; Roll, Pitch, Yaw Rates; Roll, Pitch, Yaw Angles					By: Oxford Technical Solutions
						Date: Due:
					2258	Date: 4/28/2021 Due: 4/28/2023

Table 2. Test Instrumentation and Equipment (continued)

Type	Output	Range	Accuracy, Other Primary Specs	Mfr, Model	Serial Number	Calibration Dates Last Due
Real-Time Calculation of Position and Velocity Relative to POV	Distance and Velocity to lane markings (LDW) and POV (FCW)	Lateral Lane Dist: ± 30 m Lateral Lane Velocity: ± 20 m/sec Longitudinal Range to POV: ± 200 m Longitudinal Range Rate: ± 50 m/sec	Lateral Distance to Lane Marking: ± 2 cm Lateral Velocity to Lane Marking: ± 0.02 m/sec Longitudinal Range: ± 3 cm Longitudinal Range Rate: ± 0.02 m/sec	Oxford Technical Solutions (OXTS), RT-Range	97	N/A
Microphone	Sound (to measure time at alert)	Frequency Response: 80 Hz – 20 kHz	Signal-to-noise: 64 dB, 1 kHz at 1 Pa	Audio-Technica AT899	N/A	N/A
Light Sensor	Light intensity (to measure time at alert)	Spectral Bandwidth: 440-800 nm	Rise time < 10 msec	DRI designed and developed Light Sensor	N/A	N/A
Accelerometer	Acceleration (to measure time at alert)	$\pm 5g$	$\leq 3\%$ of full range	Silicon Designs, 2210-005	N/A	N/A
Coordinate Measurement Machine	Inertial Sensing System Coordinates	0-8 ft 0-2.4 m	± 0.020 in. ± 0.51 mm (Single point articulation accuracy)	Faro Arm, Fusion	UO8-05-08-06636	By: DRI Date: 1/6/2022 Due: 1/6/2023
Type	Description			Mfr, Model	Serial Number	
Data Acquisition System	Data acquisition is achieved using a dSPACE MicroAutoBox II. Data from the Oxford IMU, including Longitudinal, Lateral, and Vertical Acceleration, Roll, Yaw, and Pitch Rate, Forward and Lateral Velocity, Roll and Pitch Angle are sent over Ethernet to the MicroAutoBox. The Oxford IMUs are calibrated per the manufacturer's recommended schedule (listed above).			dSPACE Micro-Autobox II 1401/1513		
				Base Board		549068
				I/O Board		588523

APPENDIX A

Photographs

LIST OF FIGURES

	Page
Figure A1. Front View of Subject Vehicle	A-3
Figure A2. Rear View of Subject Vehicle	A-4
Figure A3. Window Sticker (Monroney Label).....	A-5
Figure A4. Vehicle Certification Label.....	A-6
Figure A5. Tire Placard.....	A-7
Figure A6. Rear View of Principal Other Vehicle (SSV).....	A-8
Figure A7. Load Frame/Slider of SSV.....	A-9
Figure A8. Two-Rail Track and Road-Based Lateral Restraint Track	A-10
Figure A9. Steel Trench Plate.....	A-11
Figure A10. MicroAutoBox Installed in Subject Vehicle	A-12
Figure A11. Sensor for Detecting Auditory and Visual Alerts.....	A-13
Figure A12. Computer Installed in Subject Vehicle.....	A-14
Figure A13. Brake Actuator Installed in POV System.....	A-15
Figure A14. Buttons for Accessing System Setup Menus.....	A-16
Figure A15. AEB System Setup Menus	A-17
Figure A16. Visual Alert.....	A-18



Figure A1. Front View of Subject Vehicle



Figure A2. Rear View of Subject Vehicle



DESC.: **RAV4** XLE FWD SUV
 VIN: **2T3W1RFV3NC17**
 YR/MDL: 2022/444DA
 CLR: WHITE/FA20 (0040/20)
 FINAL ASSEMBLY POINT: CAMBRIDGE, ONTARIO, CANADA

GOVERNMENT 5-STAR SAFETY RATINGS

Overall Vehicle Score ★★★★★
 Based on the combined ratings of frontal, side and rollover. Should ONLY be compared to other vehicles of similar size and weight.

Frontal Crash Driver Passenger ★★★★★
 Based on the risk of injury in a frontal impact. Should ONLY be compared to other vehicles of similar size and weight.

Side Crash Front seat Rear seat ★★★★★
 Based on the risk of injury in a side impact.

Rollover ★★★★★
 Based on the risk of rollover in a single-vehicle crash.

Star ratings range from 1 to 5 stars (★ ★ ★ ★ ★) with 5 being the highest.
 Source: National Highway Traffic Safety Administration (NHTSA)
www.safercar.gov or 1-888-327-4236

STANDARD EQUIPMENT
 UNLESS REPLACED BY OPTIONAL EQUIPMENT

- MECHANICAL & PERFORMANCE**
 - 2.5L 4-Cylinder Engine w/ Start-Stop
 - 203 hp @ 6600 rpm / 184 lb-ft @ 5000 rpm
 - 8-Speed Automatic Transmission
 - Front-Wheel Drive
- SAFETY & CONVENIENCE**
 - Toyota Safety Sense 2.0: Pre-Collision Sys w/ Pedestrian Detection, Full-Speed Range Dynamic Radar Cruise Control, Lane Departure Alert w/ Steering Assist, Lane Tracing Assist, Automatic High Beams, Road Sign Assist
 - 8 Airbags; Star Safety System
 - Backup Camera
 - LATCH-Lower Anchor & Tether for Children
 - Blind Spot Monitor w/ Rear Cross-Traffic Alert
- EXTERIOR**
 - LED Projector Headlights
 - LED Daytime Running Lights
 - 17-in Five-Spoke Silver Alloy Wheels
- INTERIOR**
 - Audio - 7-in Touchscreen, 6 Speakers, Hands-Free Bluetooth Phone/Music, USB-A, Media Port, 4 USB-C Charge Ports, SiriusXM w/ 3-Month Platinum Plan Trial, Android Auto & Apple CarPlay Compatible
 - Dual Zone Auto A/C w/ Rear Air Vents
 - Fabric-Trimmed Seats
 - Power Driver's Seat
 - Smart Key System w/ Push Button Start

MANUFACTURER'S SUGGESTED RETAIL PRICE \$27,995.00

- OPTIONAL EQUIPMENT**
- FE 50 State Emissions
 - 3J Blackout Emblem Overlays 129.00
 - 3T Cross Bars 315.00
 - CF Carpet Floor Mats/Cargo Mat 269.00
 - DS Door Edge Guard 140.00
 - DK Owner's Portfolio
 - MF Mudguard 129.00

EPA DOT Fuel Economy and Environment Gasoline Vehicle

Fuel Economy Small SUVs range from 18 to 125 MPG. The best vehicle rates 142 MPG.

30 MPG combined city/hwy
 27 city 35 highway
 3.3 gallons per 100 miles

You save \$500 in fuel costs over 5 years compared to the average new vehicle.

Annual fuel cost \$1,200

Fuel Economy & Greenhouse Gas Rating (tailpipe only) **6** **Smog Rating** (tailpipe only) **7**

This vehicle emits 292 grams CO₂ per mile. The best emits 0 grams per mile (tailpipe only). Producing and distributing fuel also create emissions. Learn more at fuelconomy.gov.

Actual results will vary for many reasons, including driving conditions and how you drive and maintain your vehicle. The average new vehicle gets 27 MPG and costs \$5,500 to fuel over 5 years. Cost estimates are based on 15,000 miles per year at \$2.28 per gallon. MPG is miles per gasoline gallon equivalent. Vehicle emissions are a significant cause of climate change and smog.

fuelconomy.gov
 Calculate personalized estimates and compare vehicles

Smartphone QR Code

DELIVERY, PROCESSING AND HANDLING FEE 1,215.00

TOTAL \$30,192.00

The New Vehicle Limited Warranty provides 3-year/36,000-mile basic coverage, 5-year/60,000-mile powertrain coverage, plus 3-year/unlimited-mile corrosion-perforation coverage. See Warranty and Maintenance Guide for details. An extended service contract may be available for the vehicle. Ask dealer for details.
 Manufacturer's suggested retail price includes manufacturer's recommended pre-delivery service. Gasoline, license and title fees, applicable federal, state and local taxes and dealer and distributor installed options and accessories are not included in the manufacturer's suggested retail price.
 ToyotaCare, which covers normal factory scheduled maintenance for two years or 25,000 miles, whichever occurs first, is included as part of the sales price of the vehicle for qualifying buyers. See participating dealer for eligibility and coverage details.

Delivered by Truck to: 04836
 THLEINISOFOWO

Figure A3. Window Sticker (Monroney Label)

MFD. BY: TOYOTA MOTOR MANUFACTURING CANADA INC. 12/21

GVWR: 2090KG (4610LB)

GAWR: FRT. 1150KG (2535LB) WITH 225/65R17 TIRES,
 17x7.0J RIMS.

RR. 1150KG (2535LB) WITH 225/65R17 TIRES,
 17x7.0J RIMS.

THIS VEHICLE CONFORMS TO ALL APPLICABLE FEDERAL MOTOR
 VEHICLE SAFETY AND THEFT PREVENTION STANDARDS IN EFFECT ON
 THE DATE OF MANUFACTURE SHOWN ABOVE.

2T3W1RFV3NC17 MPV



C/TR: 040/FA20 AXAA52L-CNZMBA 010 A

A/TM: /UB80E MADE IN CANADA

Figure A4. Vehicle Certification Label



TIRE AND LOADING INFORMATION

**SEATING CAPACITY : TOTAL 5
FRONT 2 : REAR 3**

The combined weight of occupants and cargo should never exceed 410kg or 900lbs.

SEE OWNER'S
MANUAL FOR
ADDITIONAL
INFORMATION.

TIRE	SIZE	COLD TIRE PRESSURE
FRONT	225/65R17	240kPa, 35PSI
REAR	225/65R17	240kPa, 35PSI
SPARE	T165/80D17	420kPa, 60PSI

RENSEIGNEMENTS SUR LES PNEUS ET LE CHARGEMENT

**NOMBRE DE PLACES: TOTAL 5
AVANT 2 : ARRIÈRE 3**

Le poids total des occupants et du chargement ne doit jamais dépasser 410kg ou 900lb.

PNEU	DIMENSIONS	PRESSION DES PNEUS À FROID
AVANT	225/65R17	240kPa, 35PSI
ARRIÈRE	225/65R17	240kPa, 35PSI
DE SECOURS	T165/80D17	420kPa, 60PSI

VOIR LE MANUEL
DE L'USAGER
POUR PLUS DE
RENSEIGNEMENTS

PZ
OR160

Figure A5. Tire Placard



Figure A6. Rear View of Principal Other Vehicle (SSV)



Figure A7. Load Frame/Slider of SSV

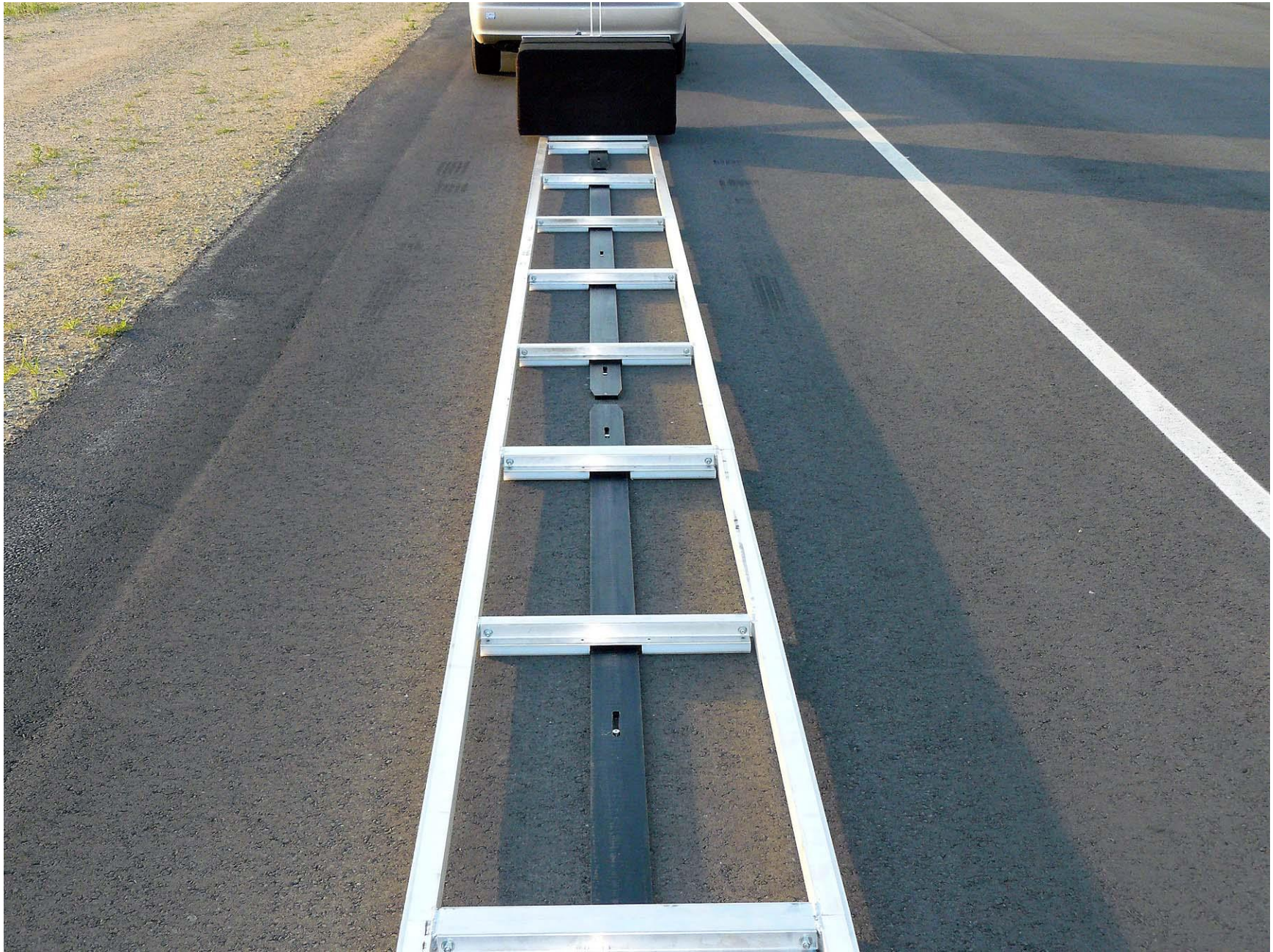

Figure A8. Two-Rail Track and Road-Based Lateral Restraint Track



Figure A9. Steel Trench Plate



Figure A10. MicroAutoBox Installed in Subject Vehicle



Figure A11. Sensor for Detecting Auditory and Visual Alerts



Figure A12. Computer Installed in Subject Vehicle



Figure A13. Brake Actuator Installed in POV System



Figure A14. Buttons for Accessing System Setup Menus

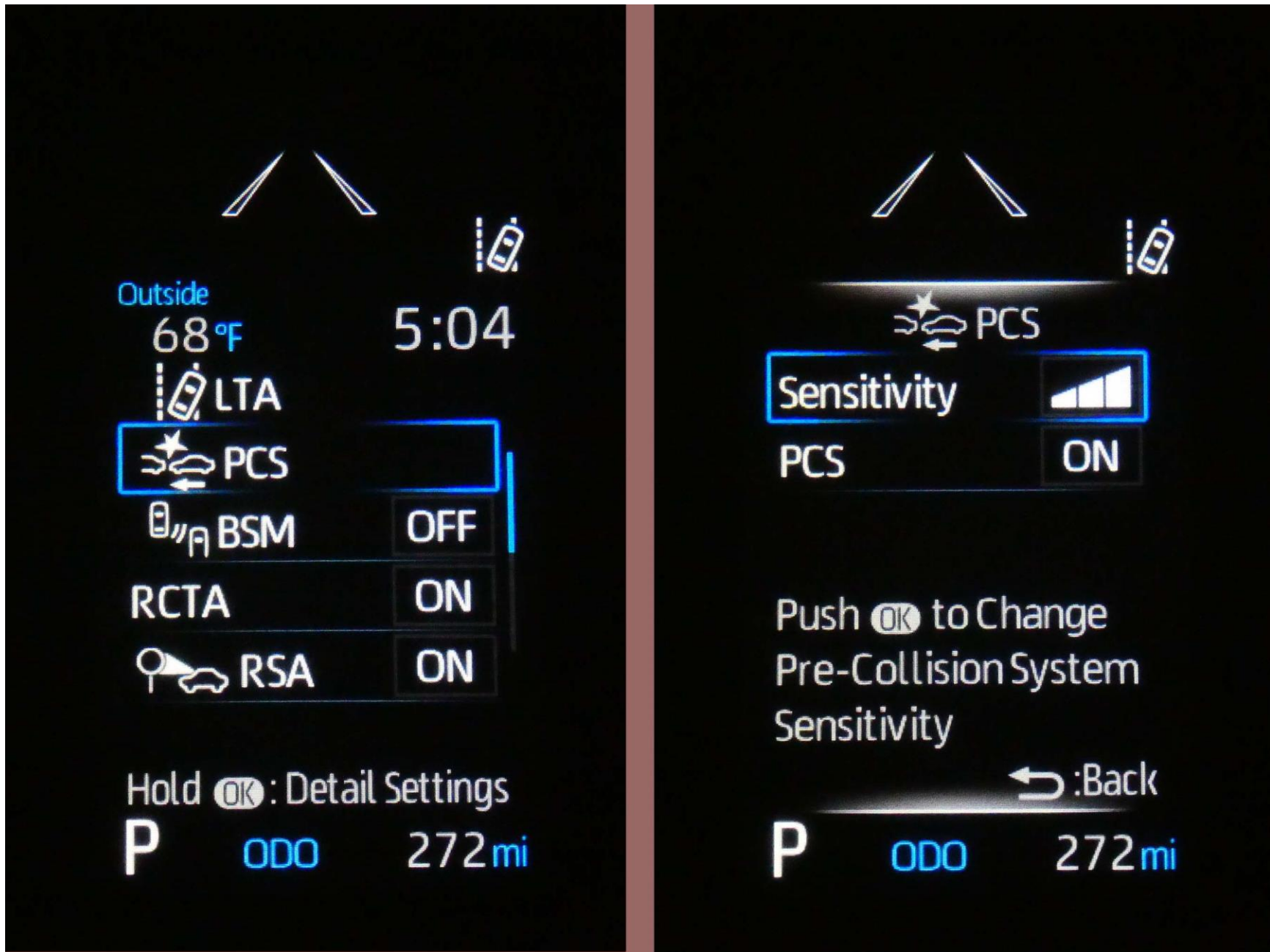

Figure A15. AEB System Setup Menus



Figure A16. Visual Alert

APPENDIX B

Excerpts from Owner's Manual

PCS (Pre-Collision System)

The pre-collision system uses a radar sensor and front camera to detect objects (→P.227) in front of the vehicle. When the system determines that the possibility of a frontal collision with an object is high, a warning operates to urge the driver to take evasive action and the potential brake pressure is increased to help the driver avoid the collision. If the system determines that the possibility of a frontal collision with an object is extremely high, the brakes are automatically applied to help avoid the collision or help reduce the impact of the collision.

The pre-collision system can be disabled/enabled and the warning timing can be changed. (→P.229)

Detectable objects

The system can detect the following:

- Vehicles
- Bicyclists
- Pedestrians

System functions

■ **Pre-collision warning**

When the system determines that the possibility of a frontal collision is high, a buzzer will sound and a warning message will be displayed on the multi-information display to urge the driver to take evasive action.

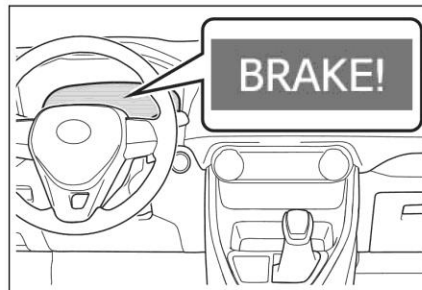

■ **Pre-collision brake assist**

When the system determines that the possibility of a frontal collision is high, the system applies greater braking force in relation to how strongly the brake pedal is depressed.

■ **Pre-collision braking**

If the system determines that the possibility of a frontal collision is extremely high, the brakes are automatically applied to help avoid the collision or reduce the impact of the collision.

**WARNING****■ Limitations of the pre-collision system**

- The driver is solely responsible for safe driving. Always drive safely, taking care to observe your surroundings.
Do not use the pre-collision system instead of normal braking operations under any circumstances. This system will not prevent collisions or lessen collision damage or injury in every situation. Do not overly rely on this system. Failure to do so may lead to an accident, resulting in death or serious injury.
- Although this system is designed to help avoid a collision or help reduce the impact of the collision, its effectiveness may change according to various conditions, therefore the system may not always be able to achieve the same level of performance.
Read the following conditions carefully. Do not overly rely on this system and always drive carefully.
- Conditions under which the system may operate even if there is no possibility of a collision:
→P.231
- Conditions under which the system may not operate properly:
→P.232
- Do not attempt to test the operation of the pre-collision system yourself.
Depending on the objects used for testing (dummies, cardboard objects imitating detectable objects, etc.), the system may not operate properly, possibly leading to an accident.

■ Pre-collision braking

- When the pre-collision braking function is operating, a large amount of braking force will be applied.
- If the vehicle is stopped by the operation of the pre-collision braking function, the pre-collision braking function operation will be canceled after approximately 2 seconds. Depress the brake pedal as necessary.
- The pre-collision braking function may not operate if certain operations are performed by the driver. If the accelerator pedal is being depressed strongly or the steering wheel is being turned, the system may determine that the driver is taking evasive action and possibly prevent the pre-collision braking function from operating.
- In some situations, while the pre-collision braking function is operating, operation of the function may be canceled if the accelerator pedal is depressed strongly or the steering wheel is turned and the system determines that the driver is taking evasive action.
- If the brake pedal is being depressed, the system may determine that the driver is taking evasive action and possibly delay the operation timing of the pre-collision braking function.

■ When to disable the pre-collision system

In the following situations, disable the system, as it may not operate properly, possibly leading to an accident resulting in death or serious injury:

- When the vehicle is being towed

- ⚠ WARNING**
- When your vehicle is towing another vehicle
 - When transporting the vehicle via truck, boat, train or similar means of transportation
 - When the vehicle is raised on a lift with the engine running and the tires are allowed to rotate freely
 - When inspecting the vehicle using a drum tester such as a chassis dynamometer or speedometer tester, or when using an on vehicle wheel balancer
 - When a strong impact is applied to the front bumper or front grille, due to an accident or other reasons
 - If the vehicle cannot be driven in a stable manner, such as when the vehicle has been in an accident or is malfunctioning
 - When the vehicle is driven in a sporty manner or off-road
 - When the tires are not properly inflated
 - When the tires are very worn
 - When tires of a size other than specified are installed
 - When tire chains are installed
 - When a compact spare tire or an emergency tire puncture repair kit is used
 - If equipment (snow plow, etc.) that may obstruct the radar sensor or front camera is temporarily installed to the vehicle

Changing settings of the pre-collision system

■ **Enabling/disabling the pre-collision system**

The pre-collision system can be enabled/disabled on the  screen (→P.94) of the multi-information display.

The system is automatically enabled each time the engine switch is turned to ON.

If the system is disabled, the PCS warning light will turn on and a message will be displayed on the multi-information display.

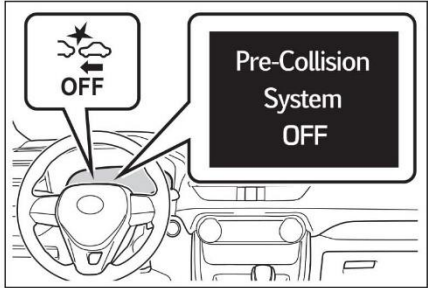

■ **Changing the pre-collision warning timing**

The pre-collision warning timing can be changed on the  screen (→P.94) of the multi-information display.

The warning timing setting is retained when the engine switch is turned to OFF. However, if the pre-collision system is disabled and re-enabled, the operation timing will return to the default setting (middle).

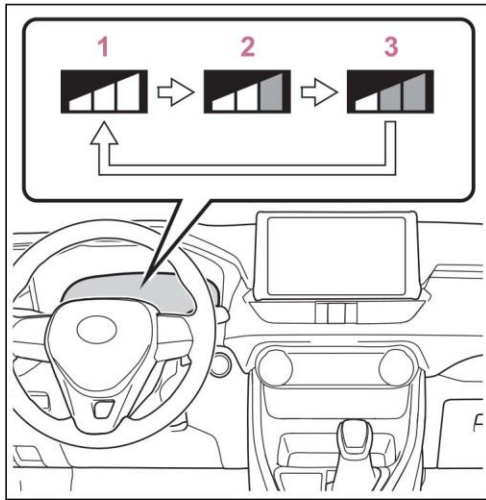

- 1** Early
- 2** Middle
This is the default setting.
- 3** Late

Operational conditions for each pre-collision function

The pre-collision system is enabled and the system determines that the possibility of a frontal collision with a detected object is high.

The system may not operate in the following situations:

- If a battery terminal has been disconnected and reconnected and then the vehicle has not been driven for a certain amount of time
- If the shift lever is in R
- When the VSC OFF indicator is illuminated (only the pre-collision warning function will be operational)

The operation speeds and operation cancellation for each function is listed below.

● Pre-collision warning

Detectable objects	Vehicle speed	Relative speed between your vehicle and object
Vehicles	Approx. 7 to 110 mph (10 to 180 km/h)	Approx. 7 to 110 mph (10 to 180 km/h)
Bicyclists and pedestrians	Approx. 7 to 50 mph (10 to 80 km/h)	Approx. 7 to 50 mph (10 to 80 km/h)

● Pre-collision brake assist

Detectable objects	Vehicle speed	Relative speed between your vehicle and object
Vehicles	Approx. 20 to 110 mph (30 to 180 km/h)	Approx. 20 to 110 mph (30 to 180 km/h)
Bicyclists and pedestrians	Approx. 20 to 50 mph (30 to 80 km/h)	Approx. 20 to 50 mph (30 to 80 km/h)

● Pre-collision braking

Detectable objects	Vehicle speed	Relative speed between your vehicle and object
Vehicles	Approx. 7 to 110 mph (10 to 180 km/h)	Approx. 7 to 110 mph (10 to 180 km/h)
Bicyclists and pedestrians	Approx. 7 to 50 mph (10 to 80 km/h)	Approx. 7 to 50 mph (10 to 80 km/h)

If either of the following occur while the pre-collision braking function is operating, it will be canceled:

- The accelerator pedal is depressed strongly.
- The steering wheel is turned sharply or abruptly.

■ Object detection function

The system detects objects based on their size, profile, motion, etc. However, an object may not be detected depending on the surrounding brightness and the motion, posture, and angle of the detected object, preventing the system from operating properly. (→P.232)
The illustration shows an image of detectable objects.

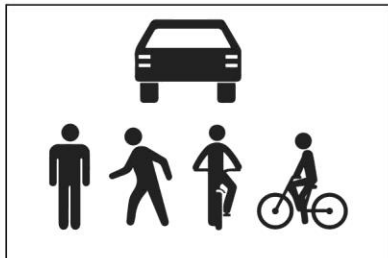

■ Conditions under which the system may operate even if there is no possibility of a collision

- In some situations such as the following, the system may determine that there is a possibility of a frontal collision and operate.
 - When passing a detectable object, etc.
 - When changing lanes while overtaking a detectable object, etc.
 - When approaching a detectable object in an adjacent lane or on the roadside, such as when changing the course of travel or

driving on a winding road

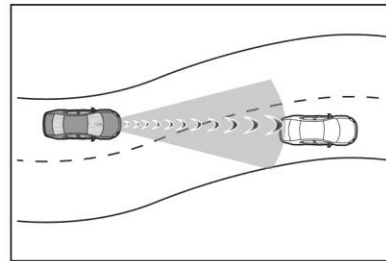

- When rapidly closing on a detectable object, etc.
- When approaching objects on the roadside, such as detectable objects, guardrails, utility poles, trees, or walls
- When there is a detectable object or other object by the roadside at the entrance of a curve

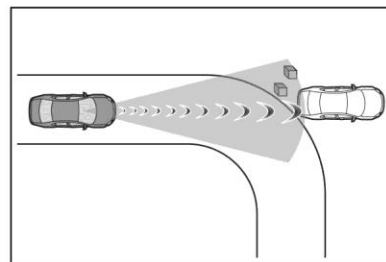

- When there are patterns or paint in front of your vehicle that may be mistaken for a detectable object
- When the front of your vehicle is hit by water, snow, dust, etc.
- When overtaking a detectable object that is changing lanes or making a right/left turn

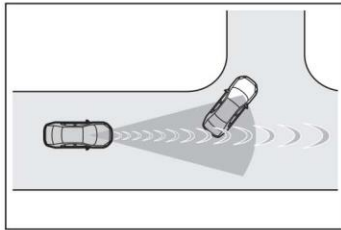

- When passing a detectable object in an oncoming lane that is stopped to make a right/left turn

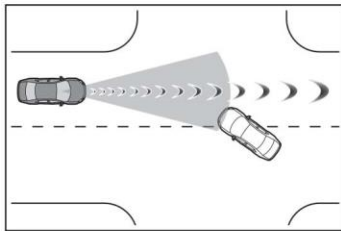

- When a detectable object approaches very close and then stops before entering the path of your vehicle
- If the front of your vehicle is raised or lowered, such as when on an uneven or undulating road surface
- When driving on a road surrounded by a structure, such as in a tunnel or on an iron bridge
- When there is a metal object (manhole cover, steel plate, etc.), steps, or a protrusion in front of your vehicle
- When passing under an object (road sign, billboard, etc.)

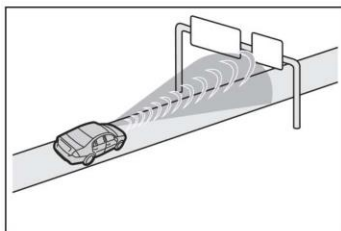

- When approaching an electric toll gate barrier, parking area barrier, or other barrier that opens and closes
- When using an automatic car wash
- When driving through or under

objects that may contact your vehicle, such as thick grass, tree branches, or a banner

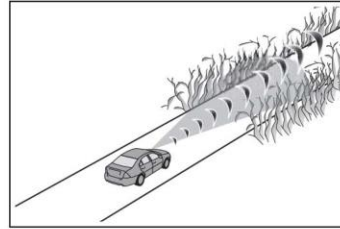

- When driving through steam or smoke
- When driving near an object that reflects radio waves, such as a large truck or guardrail
- When driving near a TV tower, broadcasting station, electric power plant, radar equipped vehicles, etc., or other location where strong radio waves or electrical noise may be present
- When there are many things which can reflect the radio waves of the radar in the vicinity (tunnels, truss bridges, gravel roads, snow covered road that have tracks, etc.)

■ **Situations in which the system may not operate properly**

- In some situations such as the following, an object may not be detected by the radar sensor and front camera, preventing the system from operating properly:
 - When a detectable object is approaching your vehicle
 - When your vehicle or a detectable object is wobbling
 - If a detectable object makes an abrupt maneuver (such as sudden swerving, acceleration or deceleration)
 - When your vehicle approaches a detectable object rapidly
 - When a detectable object is not directly in front of your vehicle

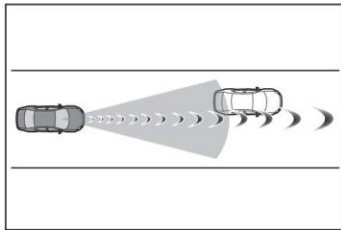

- When a detectable object is near a wall, fence, guardrail, manhole cover, vehicle, steel plate on the road, etc.
- When a detectable object is under a structure
- When part of a detectable object is hidden by an object, such as large baggage, an umbrella, or guardrail
- When there are many things which can reflect the radio waves of the radar in the vicinity (tunnels, truss bridges, gravel roads, snow covered road that have tracks, etc.)
- When there is an effect on the radio waves to the radar that is installed on another vehicle
- When multiple detectable objects are close together
- If the sun or other light is shining directly on a detectable object
- When a detectable object is a shade of white and looks extremely bright
- When a detectable object appears to be nearly the same color or brightness as its surroundings
- If a detectable object cuts or suddenly emerges in front of your vehicle
- When the front of your vehicle is hit by water, snow, dust, etc.
- When a very bright light ahead, such as the sun or the headlights of oncoming traffic, shines directly into the front camera
- When approaching the side or front of a vehicle ahead
- If a vehicle ahead is a motorcycle
- If a vehicle ahead is narrow, such as a personal mobility vehicle
- If a preceding vehicle has a small rear end, such as an unloaded

- truck
- If a preceding vehicle has a low rear end, such as a low bed trailer

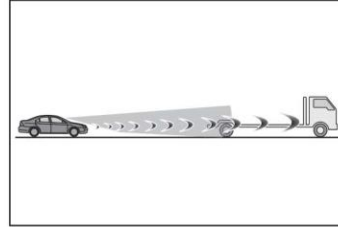

- If a vehicle ahead has extremely high ground clearance

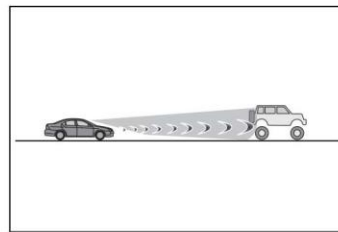

- If a vehicle ahead is carrying a load which protrudes past its rear bumper
- If a vehicle ahead is irregularly shaped, such as a tractor or side car
- If a vehicle ahead is a child sized bicycle, a bicycle that is carrying a large load, a bicycle ridden by more than one person, or a uniquely shaped bicycle (bicycle with a child seat, tandem bicycle, etc.)
- If a pedestrian/or the riding height of a bicyclist ahead is shorter than approximately 3.2 ft. (1 m) or taller than approximately 6.5 ft. (2 m)
- If a pedestrian/bicyclist is wearing oversized clothing (a rain coat, long skirt, etc.), making their silhouette obscure
- If a pedestrian is bending forward or squatting or bicyclist is bending forward
- If a pedestrian/bicyclist is moving fast
- If a pedestrian is pushing a stroller, wheelchair, bicycle or other vehicle
- When driving in inclement weather

- such as heavy rain, fog, snow or a sandstorm
- When driving through steam or smoke
- When the surrounding area is dim, such as at dawn or dusk, or while at night or in a tunnel, making a detectable object appear to be nearly the same color as its surroundings
- When driving in a place where the surrounding brightness changes suddenly, such as at the entrance or exit of a tunnel
- After the engine has started the vehicle has not been driven for a certain amount of time
- While making a left/right turn and for a few seconds after making a left/right turn
- While driving on a curve and for a few seconds after driving on a curve
- If your vehicle is skidding
- If the front of the vehicle is raised or lowered

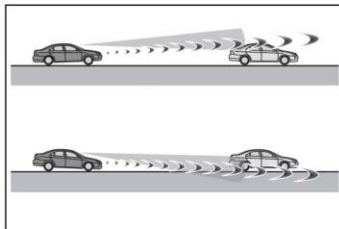

- If the wheels are misaligned
- If a wiper blade is blocking the front camera
- The vehicle is being driven at extremely high speeds
- When driving on a hill
- If the radar sensor or front camera is misaligned
- In some situations such as the following, sufficient braking force may not be obtained, preventing the system from performing properly:
 - If the braking functions cannot operate to their full extent, such as when the brake parts are extremely cold, extremely hot, or wet

- If the vehicle is not properly maintained (brakes or tires are excessively worn, improper tire inflation pressure, etc.)
- When the vehicle is being driven on a gravel road or other slippery surface
- When the road surface has deep wheel tracks
- When driving on a hill road
- When driving on a road that has inclines to the left or right

■ **If VSC is disabled**

- If VSC is disabled (→P.357), the pre-collision brake assist and pre-collision braking functions are also disabled.
- The PCS warning light will turn on and “VSC Turned Off Pre-Collision Brake System Unavailable” will be displayed on the multi-information display.

APPENDIX C

Run Log

Subject Vehicle: **2022 Toyota RAV4 XLE**

Test start date: **1/27/2022**

Principal Other Vehicle: **SSV**

Test end date: **1/27/2022**

Run	Test Type	Valid Run?	FCW TTC (s)	Min. Distance (ft)	Speed Reduction (mph)	Peak Decel. (g)	CIB TTC (s)	Pass/Fail	Notes
1	Static Run								
2	Stopped POV	Y	2.67	3.40	25.5	0.65	1.11	Pass	
3		Y	2.65	3.38	25.0	0.60	1.15	Pass	
4		Y	1.92	3.23	25.0	0.58	1.21	Pass	
5		Y	2.67	3.30	25.3	0.63	1.10	Pass	
6		Y	2.64	3.22	25.1	0.61	1.15	Pass	
7		Y	2.67	3.19	25.1	0.63	1.12	Pass	
8		Y	2.64	3.68	25.1	0.60	1.13	Pass	
9	Static Run								
10	Slower POV, 25 vs 10	Y	2.27	3.22	14.8	0.48	0.93	Pass	
11		Y	2.25	2.47	15.4	0.47	0.93	Pass	
12		Y	2.23	2.79	14.8	0.46	0.92	Pass	
13		Y	2.25	2.94	15.0	0.47	0.91	Pass	
14		Y	2.27	3.08	15.0	0.49	0.90	Pass	
15		Y	2.25	2.92	15.4	0.50	0.89	Pass	
16		Y	2.22	2.95	15.3	0.52	0.88	Pass	

Run	Test Type	Valid Run?	FCW TTC (s)	Min. Distance (ft)	Speed Reduction (mph)	Peak Decel. (g)	CIB TTC (s)	Pass/Fail	Notes
17	Static Run								
18	Slower POV, 45 vs 20	Y	2.13	2.08	25.5	0.61	1.10	Pass	
19		Y	2.69	2.21	24.6	0.80	1.01	Pass	
20		Y	2.67	0.00	22.6	0.87	1.12	Pass	
21		Y	2.66	1.95	24.5	0.64	1.03	Pass	
22		Y	2.65	1.67	25.7	0.73	0.98	Pass	
23		Y	2.67	1.85	24.9	0.69	1.01	Pass	
24		Y	2.14	2.09	25.6	0.70	1.05	Pass	
25	Static run								
26	Decelerating POV, 35	Y	1.54	3.82	28.9	0.76	1.19	Pass	
27		N							SV Speed
28		Y	1.68	4.02	30.5	0.72	1.10	Pass	
29		Y	1.56	3.30	29.0	0.84	1.06	Pass	
30		Y	1.60	3.51	30.3	0.74	1.04	Pass	
31		Y	1.35	3.25	29.8	1.04	1.17	Pass	
32		Y	1.63	3.89	28.3	0.83	1.04	Pass	
33	Y	1.57	3.24	30.4	0.68	1.16	Pass		
34	Static Run								
35	STP False Positive, 25	Y				0.01		Pass	

Run	Test Type	Valid Run?	FCW TTC (s)	Min. Distance (ft)	Speed Reduction (mph)	Peak Decel. (g)	CIB TTC (s)	Pass/Fail	Notes	
36	STP False Positive, 25	N							Throttle Release	
37		Y				0.01		Pass		
38		Y					0.01		Pass	
39		Y					0.01		Pass	
40		Y					0.01		Pass	
41		Y					0.01		Pass	
42		Y					0.01		Pass	
43	STP - Static Run									
44	STP False Positive, 45	Y				0.02		Pass		
45		Y				0.01		Pass		
46		Y					0.00		Pass	
47		Y					0.01		Pass	
48		Y					0.01		Pass	
49		Y					0.00		Pass	
50	Y					0.02		Pass		
51	STP - Static Run									

APPENDIX D

Time History Plots

LIST OF FIGURES

	Page
Figure D1. Example Time History for Stopped POV, Passing.....	D-9
Figure D2. Example Time History for Slower POV 25 vs. 10, Passing.....	D-10
Figure D3. Example Time History for Slower POV 45 vs. 20, Passing.....	D-11
Figure D4. Example Time History for Decelerating POV 35, Passing	D-12
Figure D5. Example Time History for False Positive STP 25, Passing	D-13
Figure D6. Example Time History for False Positive STP 45, Passing	D-14
Figure D7. Example Time History Displaying Invalid Headway Criteria	D-15
Figure D8. Example Time History Displaying Various Invalid Criteria	D-16
Figure D9. Example Time History for a Failed Run	D-17
Figure D10. Time History for CIB Run 2, Test 1 - Stopped POV	D-18
Figure D11. Time History for CIB Run 3, Test 1 - Stopped POV	D-19
Figure D12. Time History for CIB Run 4, Test 1 - Stopped POV	D-20
Figure D13. Time History for CIB Run 5, Test 1 - Stopped POV	D-21
Figure D14. Time History for CIB Run 6, Test 1 - Stopped POV	D-22
Figure D15. Time History for CIB Run 7, Test 1 - Stopped POV	D-23
Figure D16. Time History for CIB Run 8, Test 1 - Stopped POV	D-24
Figure D17. Time History for CIB Run 10, Test 2 - Slower Moving POV, 25/10 mph	D-25
Figure D18. Time History for CIB Run 11, Test 2 - Slower Moving POV, 25/10 mph	D-26
Figure D19. Time History for CIB Run 12, Test 2 - Slower Moving POV, 25/10 mph	D-27
Figure D20. Time History for CIB Run 13, Test 2 - Slower Moving POV, 25/10 mph	D-28
Figure D21. Time History for CIB Run 14, Test 2 - Slower Moving POV, 25/10 mph	D-29
Figure D22. Time History for CIB Run 15, Test 2 - Slower Moving POV, 25/10 mph	D-30
Figure D23. Time History for CIB Run 16, Test 2 - Slower Moving POV, 25/10 mph	D-31
Figure D24. Time History for CIB Run 18, Test 2 - Slower Moving POV, 45/20 mph	D-32
Figure D25. Time History for CIB Run 19, Test 2 - Slower Moving POV, 45/20 mph	D-33
Figure D26. Time History for CIB Run 20, Test 2 - Slower Moving POV, 45/20 mph	D-34
Figure D27. Time History for CIB Run 21, Test 2 - Slower Moving POV, 45/20 mph	D-35
Figure D28. Time History for CIB Run 22, Test 2 - Slower Moving POV, 45/20 mph	D-36
Figure D29. Time History for CIB Run 23, Test 2 - Slower Moving POV, 45/20 mph	D-37
Figure D30. Time History for CIB Run 24, Test 2 - Slower Moving POV, 45/20 mph	D-38
Figure D31. Time History for CIB Run 26, Test 3 - Decelerating POV 35 mph	D-39
Figure D32. Time History for CIB Run 28, Test 3 - Decelerating POV 35 mph	D-40
Figure D33. Time History for CIB Run 29, Test 3 - Decelerating POV 35 mph	D-41
Figure D34. Time History for CIB Run 30, Test 3 - Decelerating POV 35 mph	D-42
Figure D35. Time History for CIB Run 31, Test 3 - Decelerating POV 35 mph	D-43
Figure D36. Time History for CIB Run 32, Test 3 - Decelerating POV 35 mph	D-44
Figure D37. Time History for CIB Run 33, Test 3 - Decelerating POV 35 mph	D-45
Figure D38. Time History for CIB Run 35, Test 4 - False Positive STP, 25 mph.....	D-46
Figure D39. Time History for CIB Run 37, Test 4 - False Positive STP, 25 mph.....	D-47
Figure D40. Time History for CIB Run 38, Test 4 - False Positive STP, 25 mph.....	D-48
Figure D41. Time History for CIB Run 39, Test 4 - False Positive STP, 25 mph.....	D-49

Figure D42. Time History for CIB Run 40, Test 4 - False Positive STP, 25 mph..... D-50
Figure D43. Time History for CIB Run 41, Test 4 - False Positive STP, 25 mph..... D-51
Figure D44. Time History for CIB Run 42, Test 4 - False Positive STP, 25 mph..... D-52
Figure D45. Time History for CIB Run 44, Test 4 - False Positive STP, 45 mph..... D-53
Figure D46. Time History for CIB Run 45, Test 4 - False Positive STP, 45 mph..... D-54
Figure D47. Time History for CIB Run 46, Test 4 - False Positive STP, 45 mph..... D-55
Figure D48. Time History for CIB Run 47, Test 4 - False Positive STP, 45 mph..... D-56
Figure D49. Time History for CIB Run 48, Test 4 - False Positive STP, 45 mph..... D-57
Figure D50. Time History for CIB Run 49, Test 4 - False Positive STP, 45 mph..... D-58
Figure D51. Time History for CIB Run 50, Test 4 - False Positive STP, 45 mph..... D-59

Description of Time History Plots

A set of time history plots is provided for each valid run in the test series. Each set of plots comprises time varying data from both the Subject Vehicle (SV) and the Principal Other Vehicle (POV), as well as pass/fail envelopes and thresholds. The following is a description of data types shown in the time history plots, as well as a description of the color codes indicating to which vehicle the data pertain.

Time History Plot Description

Each time history plot consists of data relevant to the test type under consideration, and therefore the data channels plotted vary according to test type. The test types (shown in the plot titles) include:

- Stopped POV (SV at 25 mph)
- Slower POV, 25/10 (SV at 25 mph, POV at 10 mph)
- Slower POV, 45/20 (SV at 45 mph, POV at 20 mph)
- Decelerating POV 35 mph (Both vehicles at 35 mph with 13.8 m gap, POV brakes at 0.3 g)
- False Positive STP 25 mph (Steel trench plate run over at 25 mph)
- False Positive STP 45 mph (Steel trench plate run over at 45 mph)

Time history figures include the following sub-plots:

- FCW Warning – Displays the Forward Collision Warning alert (which can be auditory, visual, or haptic). Depending on the type of FCW alert or instrumentation used to measure the alert, this can be any combination of the following:
 - Filtered, rectified, and normalized sound signal. The vertical scale is 0 to 1.
 - Filtered, rectified, and normalized acceleration (i.e., haptic alert, such as steering wheel vibration). The vertical scale is 0 to 1.
 - Normalized light sensor signal. The vertical scale is 0 to 1.

As only the auditory or haptic alert is perceptible by the driver during a test run, the earliest of either of these alerts is used to define the onset of the FCW alert. A vertical black bar on the plot indicates the TTC (sec) at the first moment of the warning issued by the FCW system. The FCW TTC is displayed to the right of the subplot in green. For False Positive tests, when the FCW presents a warning “FCW” is shown in red at the right edge of the FCW plot.

- Headway (ft) – Longitudinal separation (gap) between the frontmost point of the Subject Vehicle and the rearmost point of the Strikeable Surrogate Vehicle (SSV) towed by the Principal Other Vehicle. The minimum headway during the run is displayed to the right of the subplot.
- SV/POV Speed (mph) – Speed of the Subject Vehicle and Principal Other Vehicle (if any). For CIB tests, the speed reduction experienced by the Subject Vehicle is displayed to the right of the subplot.
- Yaw Rate (deg/sec) – Yaw rate of the Subject Vehicle and Principal Other Vehicle (if any).
- Lateral Offset (ft) – Lateral offset within the lane of the Subject Vehicle to the center of the lane of travel. Note that for tests involving the Strikeable Surrogate Vehicle (SSV), the associated lateral restraint track is defined to be the center of the lane of travel. If testing is done with a different POV which does not have a lateral restraint track, lateral offset is defined to be the lateral offset between the SV and POV.
- Ax (g) – Longitudinal acceleration of the Subject Vehicle and Principal Other Vehicle (if any). For CIB tests, the TTC (sec) at the moment of first CIB activation is displayed to the right of the subplot in green. Also, the peak value of Ax for the SV is shown on the subplot.
- Accelerator Pedal Position (0-1) – Normalized position of the accelerator pedal.

Envelopes and Thresholds

Some of the time history plot figures contain either green or yellow envelopes and/or black threshold lines. These envelopes and thresholds are used to programmatically and visually determine the validity of a given test run. Envelope and threshold exceedances are indicated with either red shading or red asterisks, and red text is placed to the right side of the plot indicating the type of exceedance. Such exceedances indicate either that the test was invalid or that the requirements of the test were not met (i.e., failure of the AEB system).

For plots with green envelopes, in order for the test to be valid, the time-varying data must not exceed the envelope boundaries at any time. Exceedances of a green envelope are indicated by red shading in the area between the measured time-varying data and the envelope boundaries.

For plots with yellow envelopes, in order for the test to be valid, the time-varying data must not exceed the envelope at the beginning (left edge of the boundary) and/or end (right edge), but may exceed the boundary during the time

between the left and right edges. Exceedances at the left or right extent of a yellow envelope are indicated by red asterisks.

For the headway plot, a dashed black threshold line indicating a relative headway of zero is displayed. If no impact occurs, a green circle is displayed at the moment of minimum distance. If impact occurs, a red asterisk is displayed at the moment of impact.

For the Ax plot, if the scenario is an AEB brake-to-stop scenario, a vertical dashed black line is displayed for all plots indicating the moment of first POV braking. The yellow envelope in this case is relevant to the POV braking only. The left edge of the envelope is at 1.5 seconds after the first POV braking. A solid black threshold line extends horizontally 0.5 seconds to the left of the envelope. This threshold line represents the time during which the Ax of the Principal Other Vehicle must first achieve 0.27 g (the upper edge of the envelope). A green circle or red asterisk is displayed at the moment the POV brake level achieves 0.27 g. A green circle indicates that the test was valid (the threshold was crossed during the appropriate interval) and a red asterisk indicates that the test was invalid (the threshold was crossed outside of the appropriate interval). Additionally, for the CIB tests, a dashed black threshold line indicating an Ax of -0.15 g is given to define the onset of CIB activation. When the Subject Vehicle's Ax crosses this threshold, the CIB TTC is calculated and displayed.

For the accelerator pedal position plot, a green envelope is given starting 500 ms after the onset of the FCW warning to ensure that the accelerator pedal was released at the correct time and remained off for the duration of the CIB event. For false positive runs a green dot, rather than a green envelope is displayed. The green dot indicates that at the end of the run the accelerator pedal had not been released. If the accelerator had been released a red asterisk would appear.

Color Codes

Color codes have been adopted to easily identify which data correspond to which vehicle, as well as to indicate the types of envelopes and thresholds used in the plots.

Color codes can be broken into four categories:

1. Time-varying data
2. Validation envelopes and thresholds
3. Individual data points
4. Text

1. Time-varying data color codes:

- Blue = Subject Vehicle data
- Magenta = Principal Other Vehicle data
- Brown = Relative data between SV and POV (i.e., TTC, lateral offset and headway distance)

2. Validation envelope and threshold color codes:

- Green envelope = time varying data must be within the envelope at all times in order to be valid
- Yellow envelope = time varying data must be within limits at left and/or right ends
- Black threshold (Solid) = time varying data must cross this threshold in the time period shown in order to be valid
- Black threshold (Dashed) = for reference only – this can include warning level thresholds, TTC thresholds, and acceleration thresholds

3. Individual data point color codes:

- Green circle = passing or valid value at a given moment in time
- Red asterisk = failing or invalid value at a given moment in time

4. Text color codes:

- Green = passing or valid value
- Red = failing or invalid value

Other Notations

- NG – Indicates that the value for that variable was outside of bounds and therefore “No Good”.
- No Wng – No warning was detected.
- POV – Indicates that the value for the Principal Other Vehicle was out of bounds.
- SV – Indicates that the value for the Subject Vehicle was out of bounds.
- SR – Shows the speed reduction value.
- Thr – Indicates that the requirements for the throttle were not met.

The minimum (worst) GPS fix type is displayed in the lower right corner of each page. The only valid fix type is RTK fixed (displayed in green). If the fix type during any portion of the test was anything other than RTK fixed, then “RTK Fixed OR LESS!!” is displayed in red.

Examples of time history plots for each test type (including passing, failing and invalid runs) are shown in Figure D1 through Figure D9. Figures D1 through D6 show passing runs for each of the 6 test types. Figures D7 and D8 show examples of invalid runs. Figure D9 shows an example of a valid test that failed the CIB requirements.

Time history data plots for the tests of the vehicle under consideration herein are provided beginning with Figure D10.

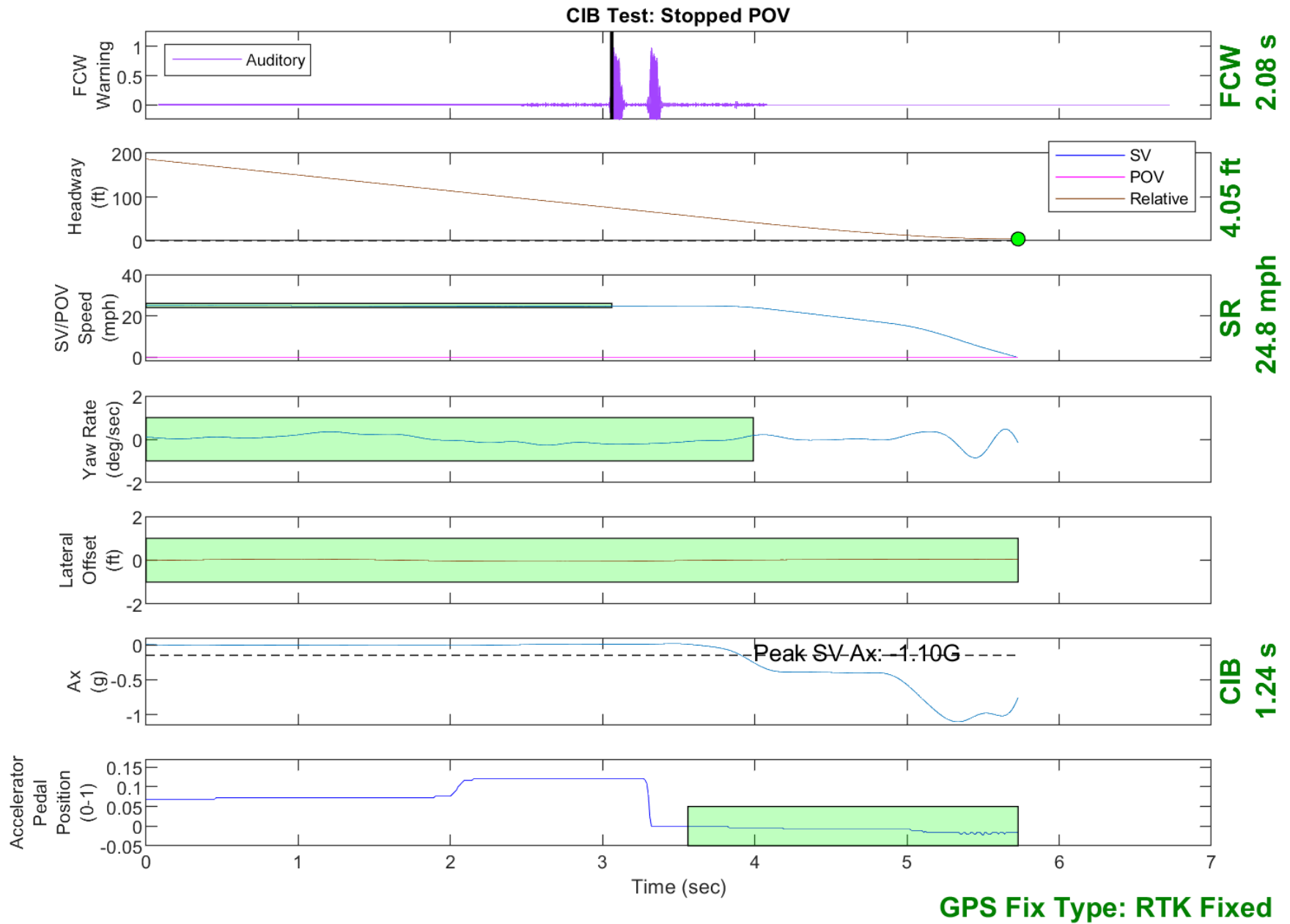

Figure D1. Example Time History for Stopped POV, Passing

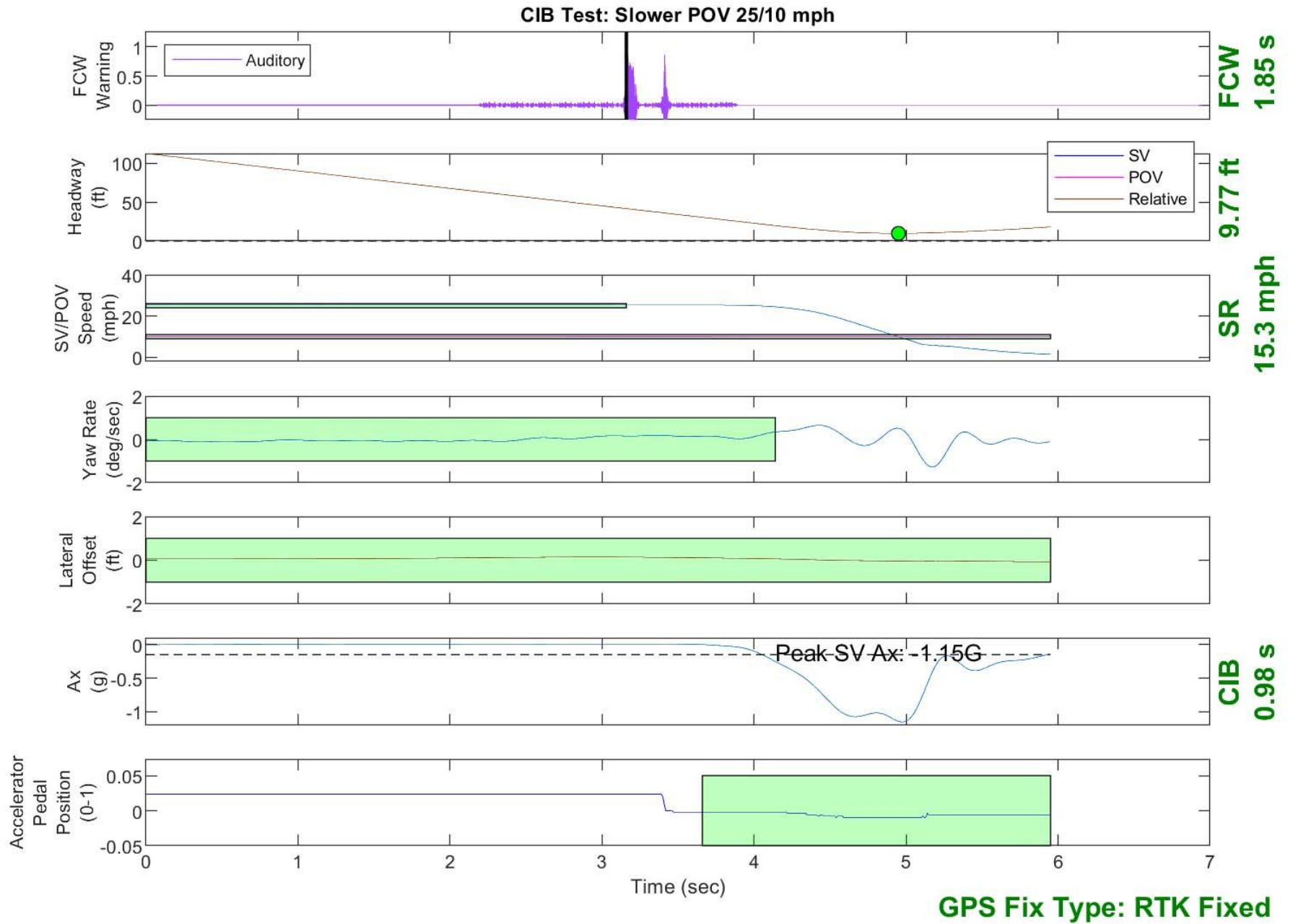

Figure D2. Example Time History for Slower POV 25 vs. 10, Passing

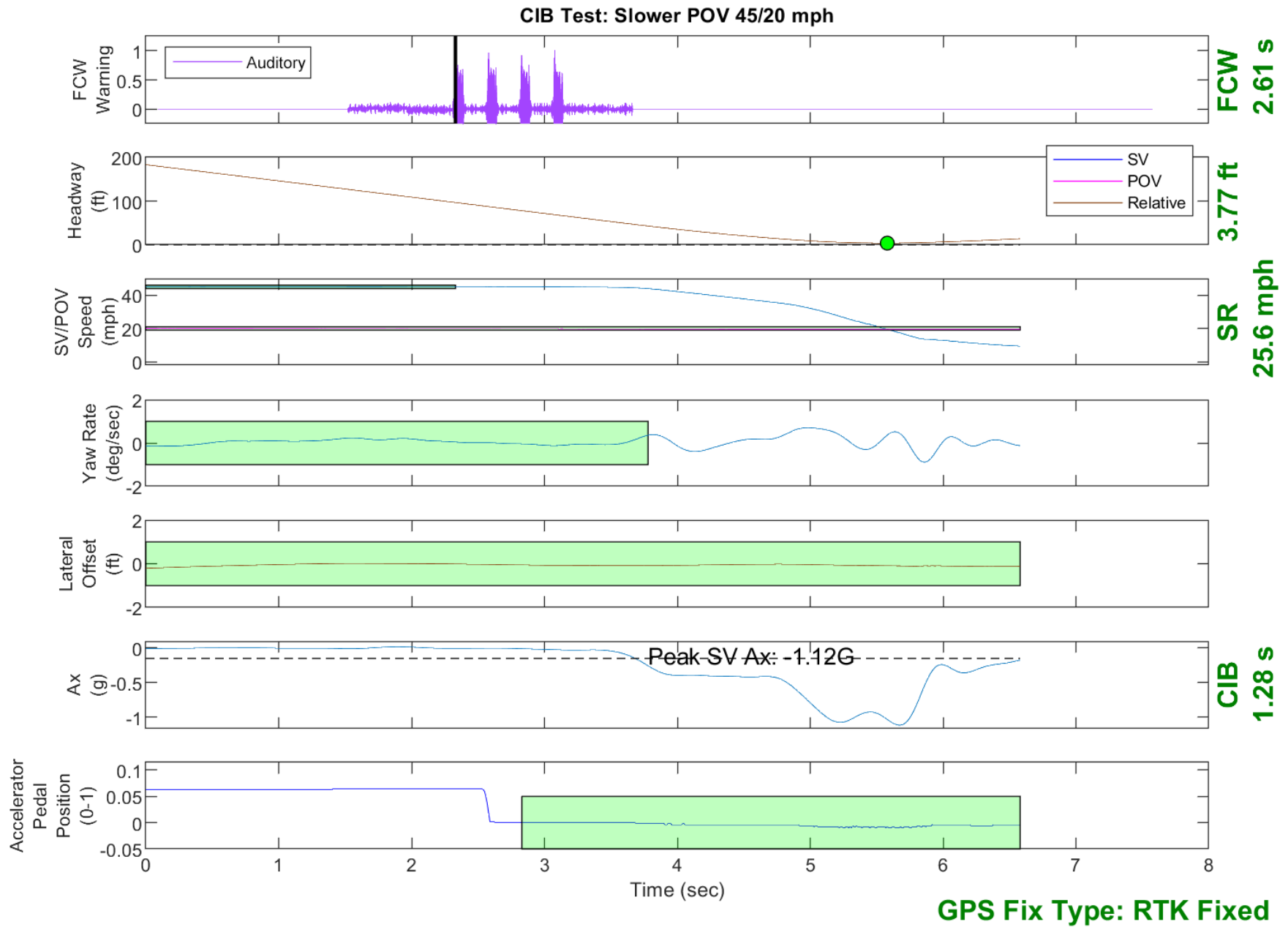

Figure D3. Example Time History for Slower POV 45 vs. 20, Passing

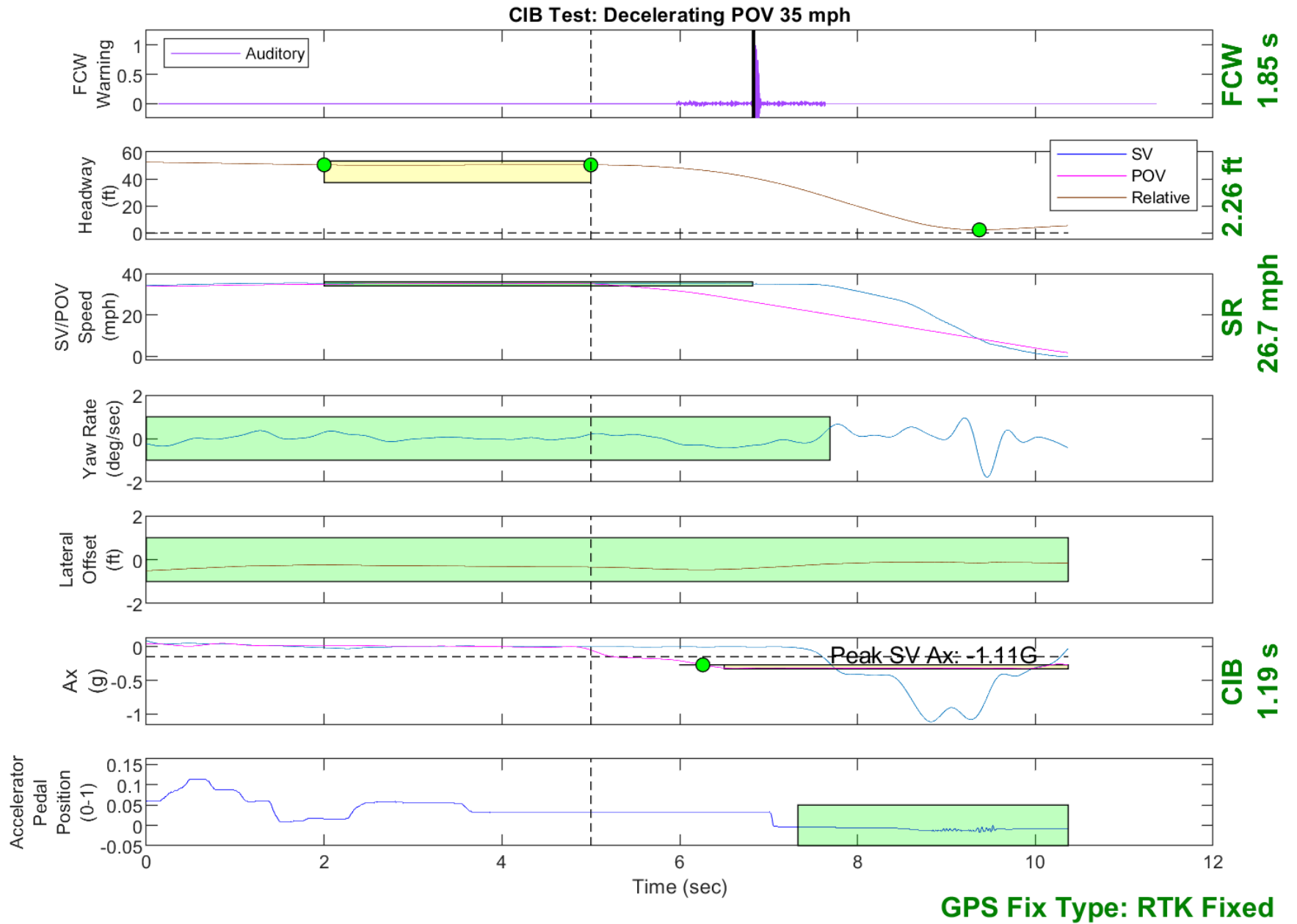

Figure D4. Example Time History for Decelerating POV 35, Passing

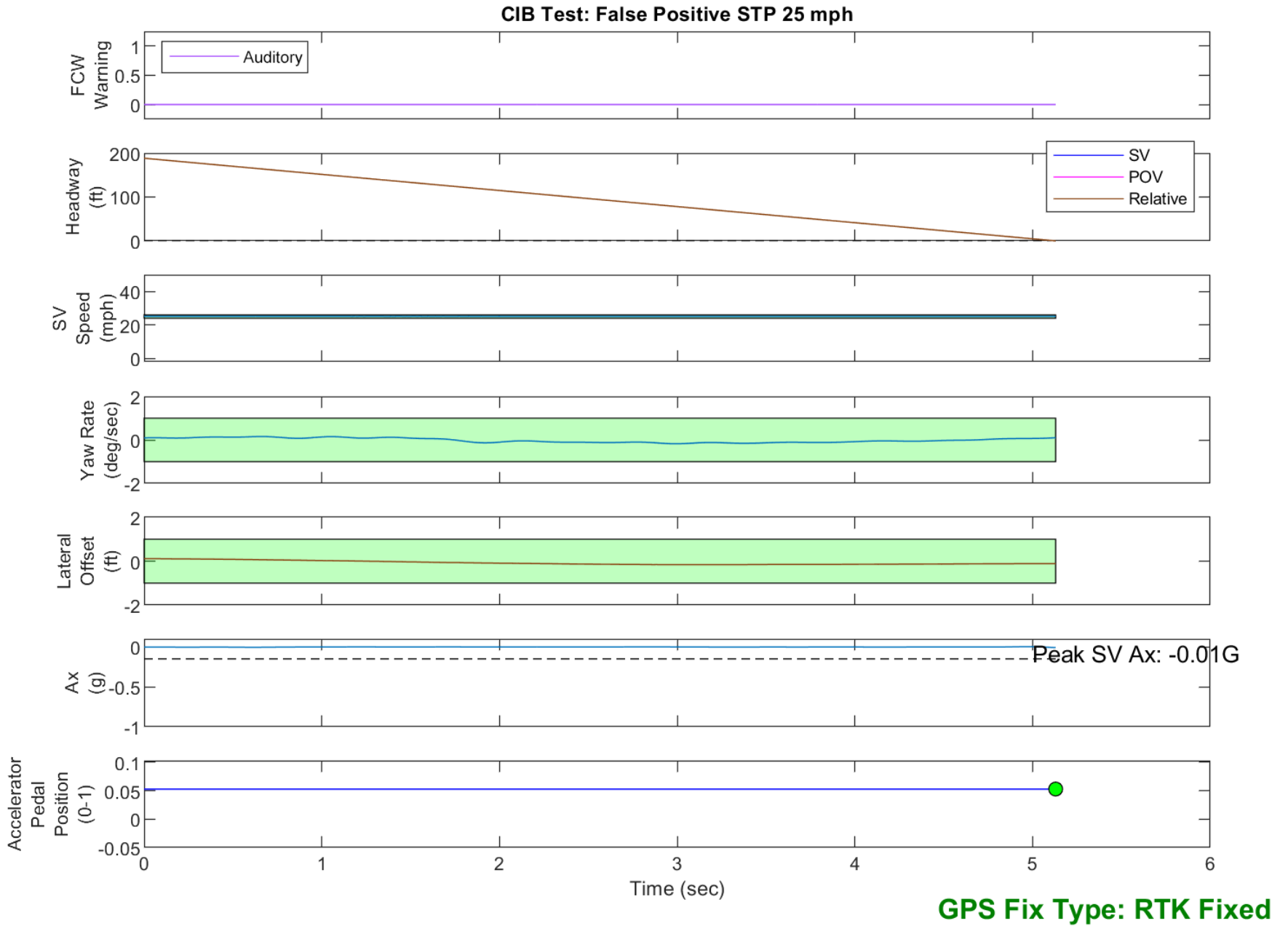

Figure D5. Example Time History for False Positive STP 25, Passing

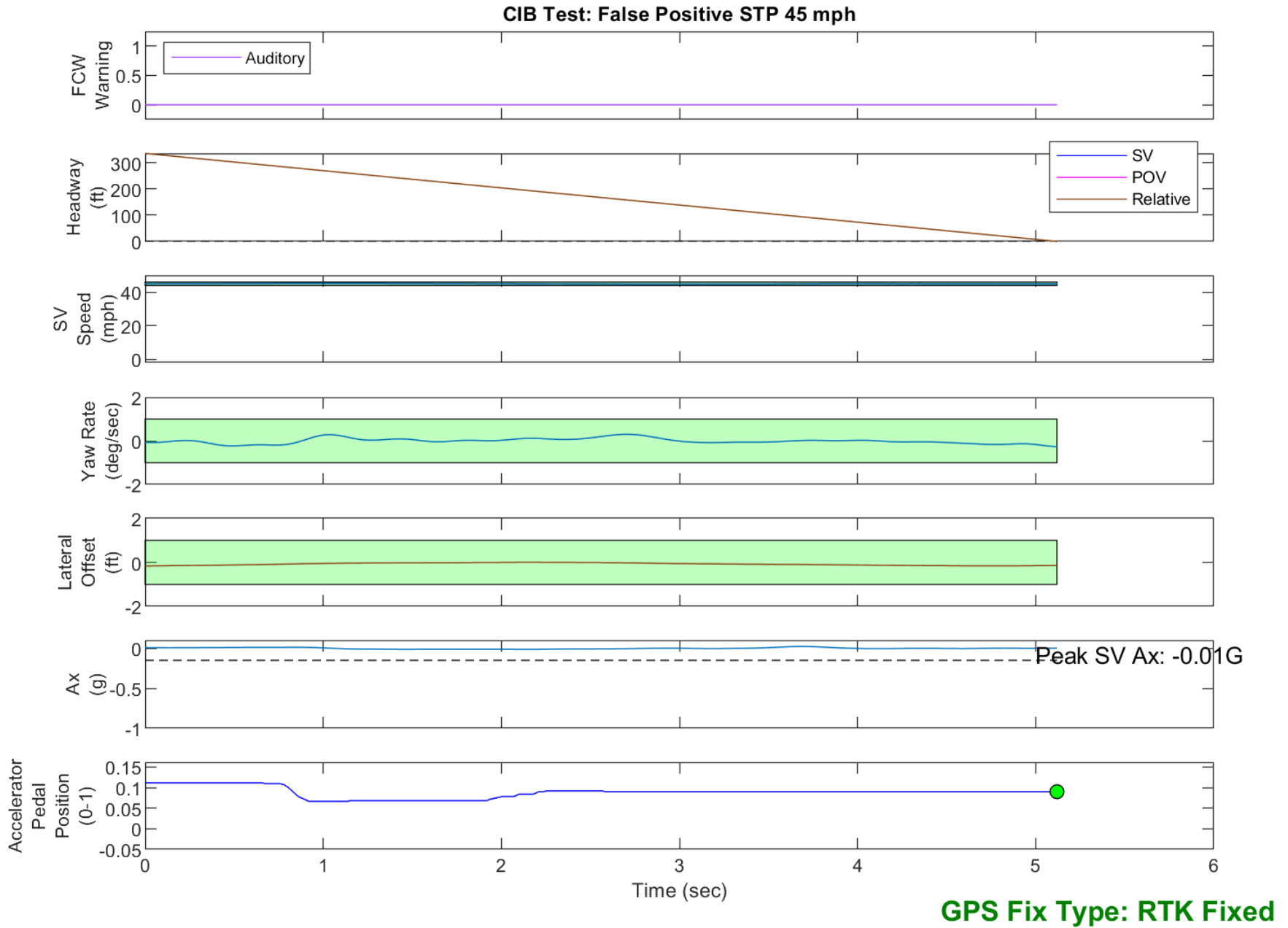

Figure D6. Example Time History for False Positive STP 45, Passing

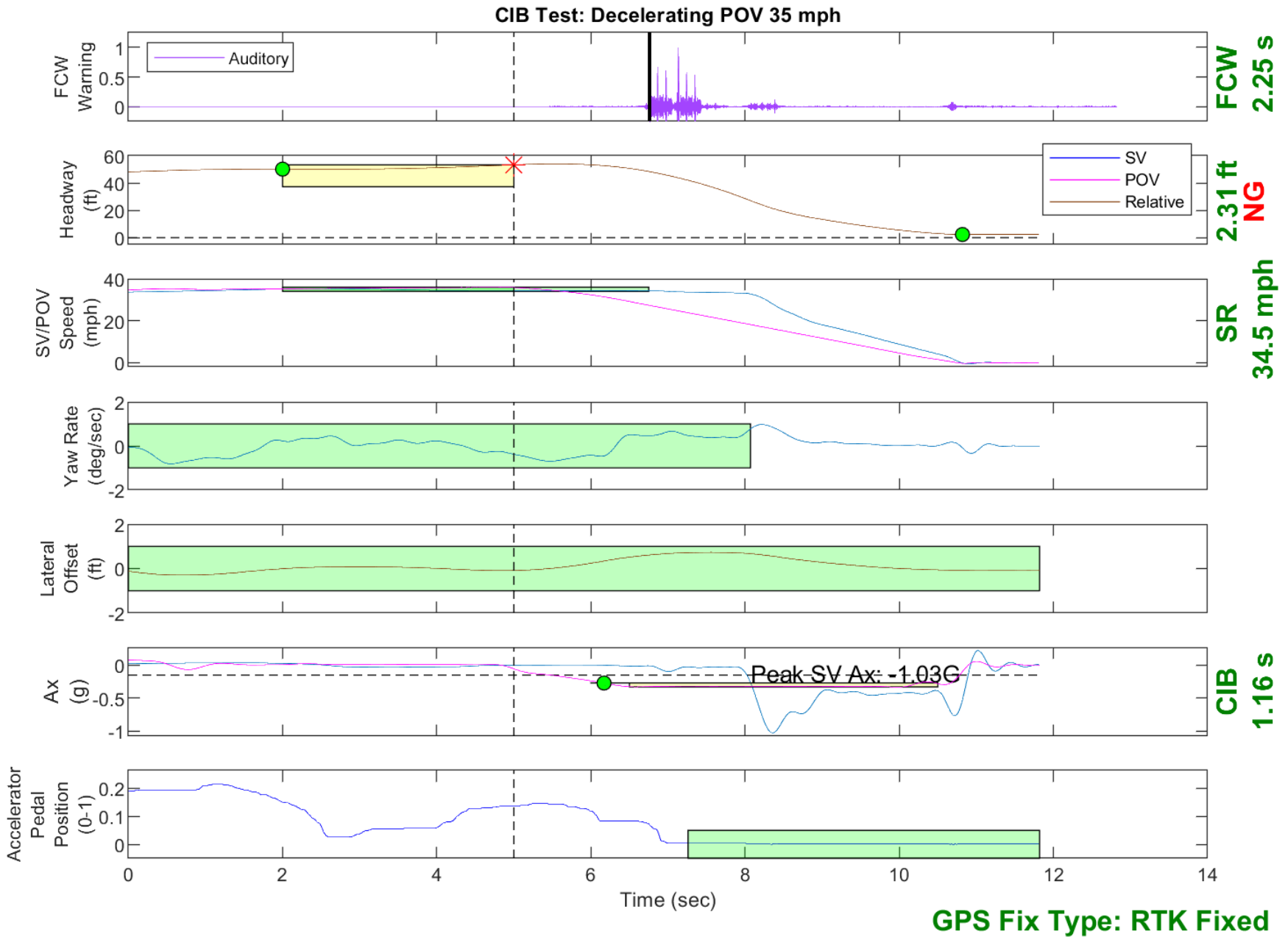

Figure D7. Example Time History Displaying Invalid Headway Criteria

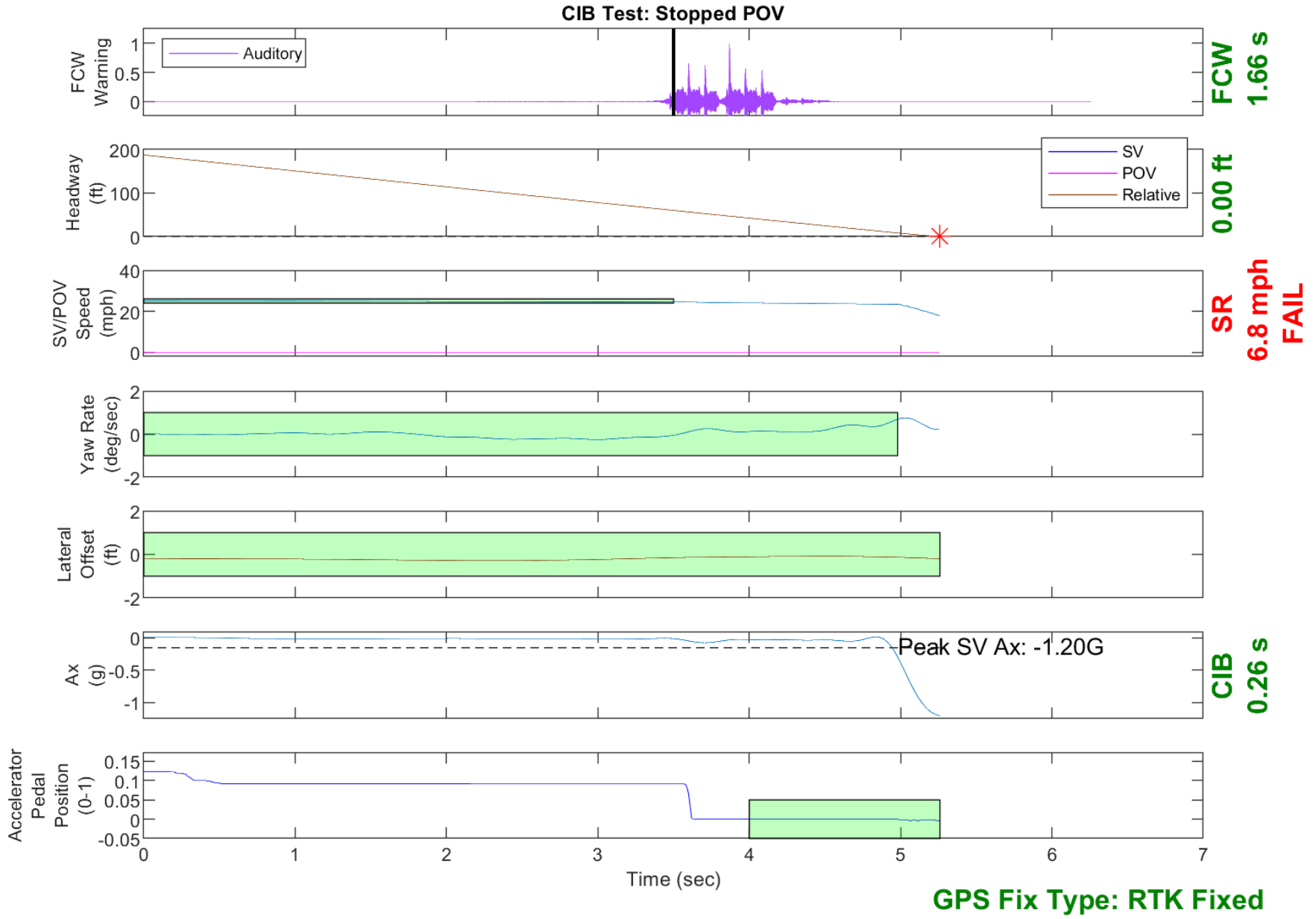

Figure D9. Example Time History for a Failed Run

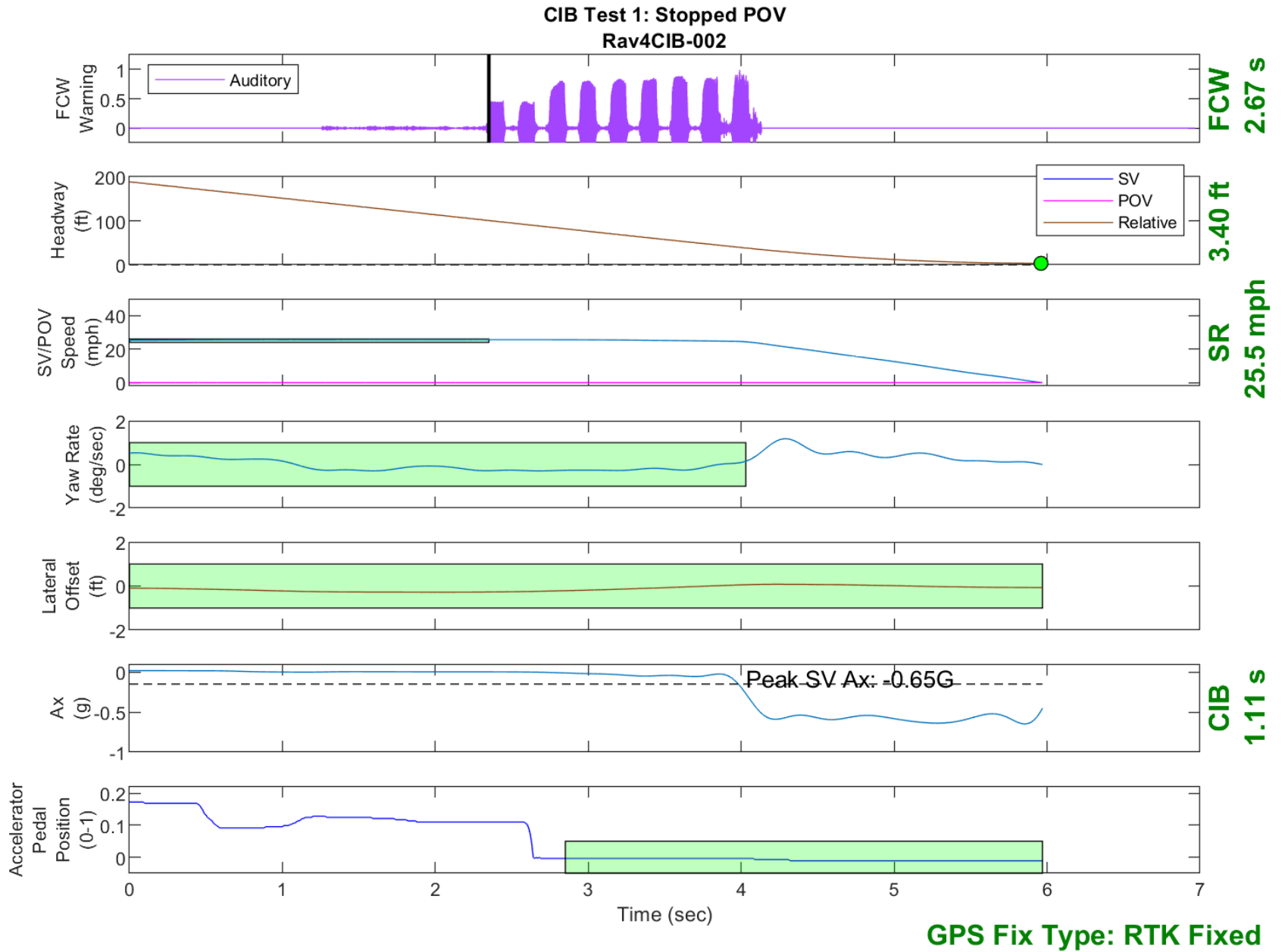

Figure D10. Time History for CIB Run 2, Test 1 - Stopped POV

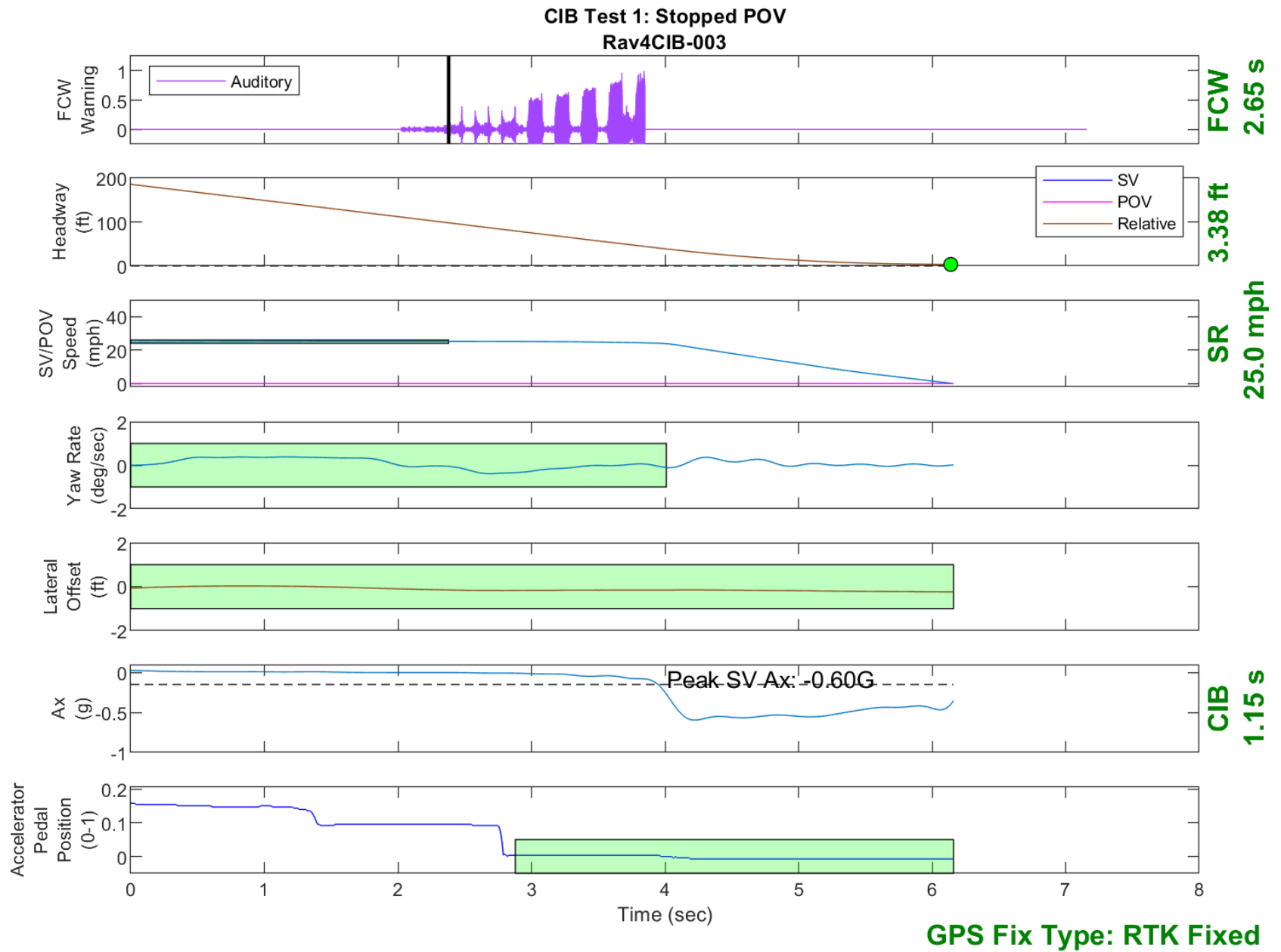

Figure D11. Time History for CIB Run 3, Test 1 - Stopped POV

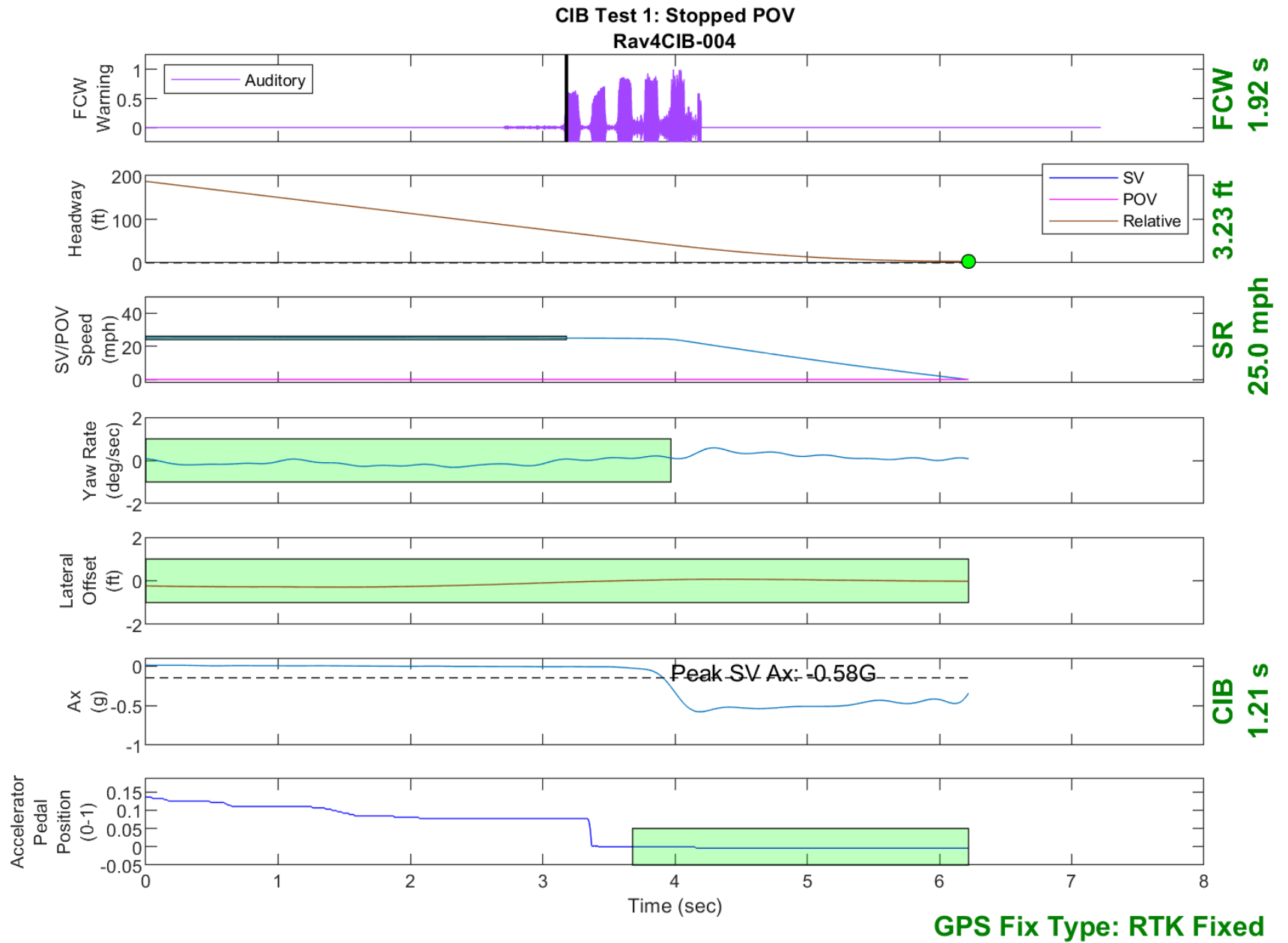

Figure D12. Time History for CIB Run 4, Test 1 - Stopped POV

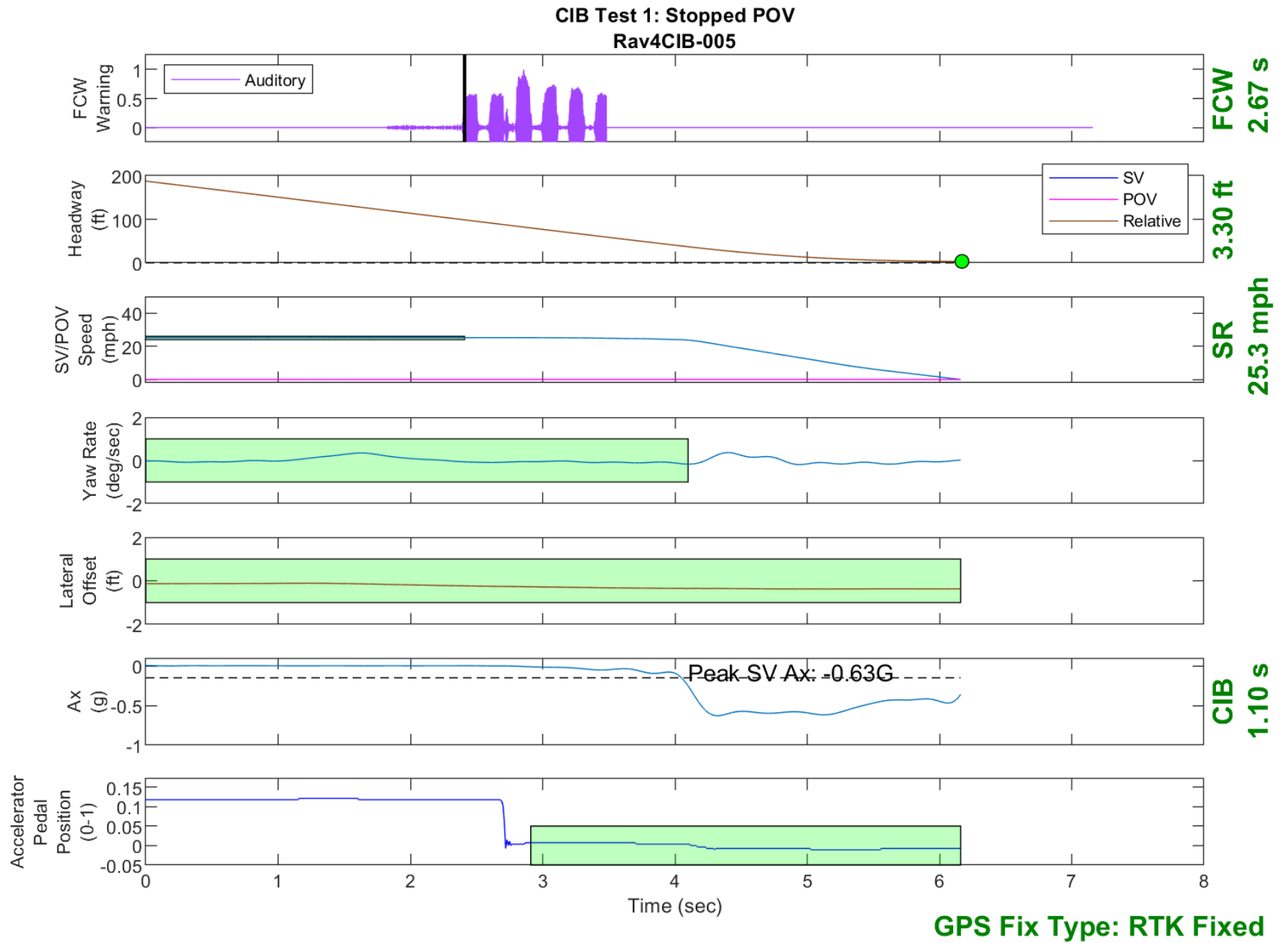

Figure D13. Time History for CIB Run 5, Test 1 - Stopped POV

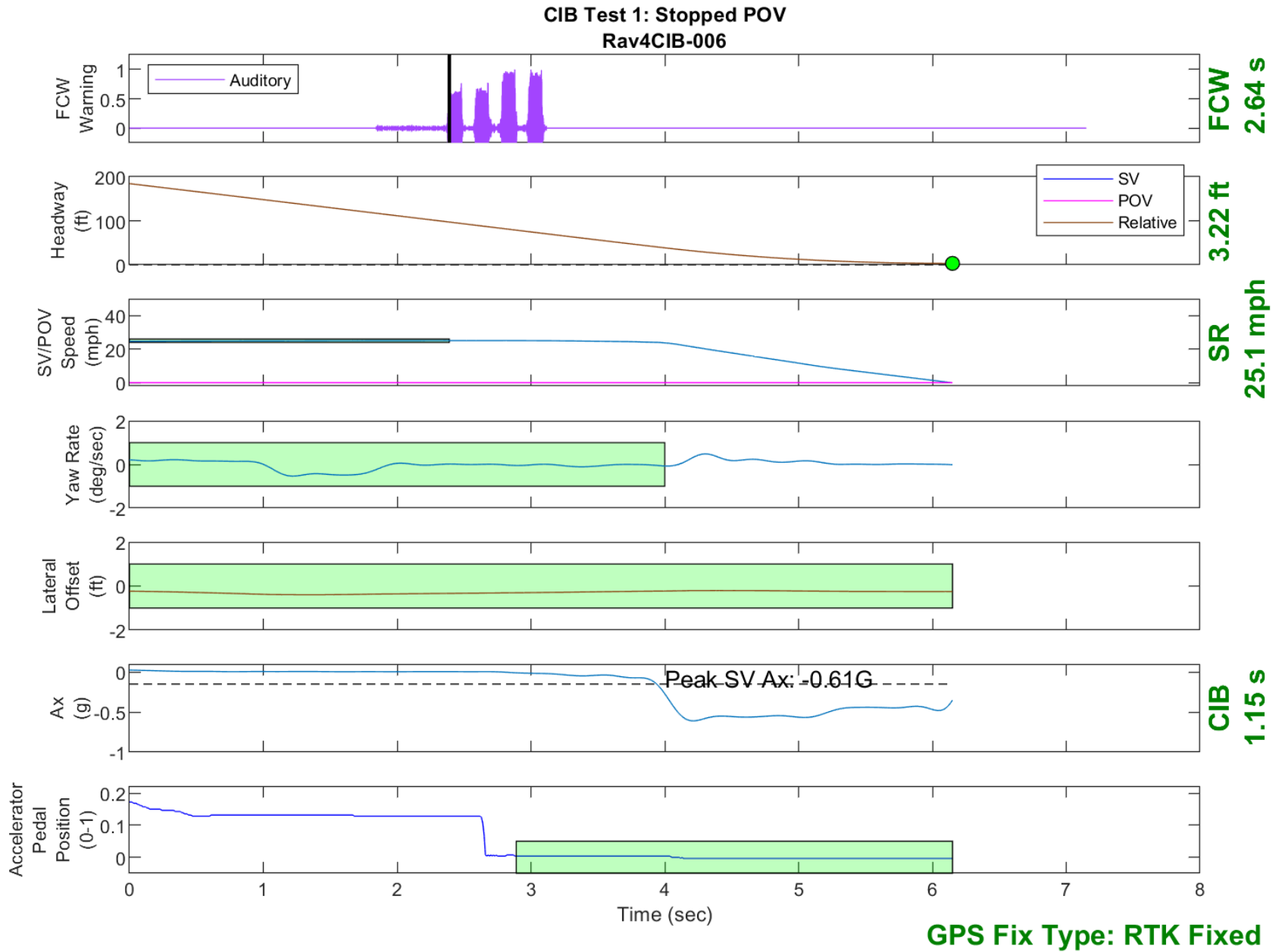

Figure D14. Time History for CIB Run 6, Test 1 - Stopped POV

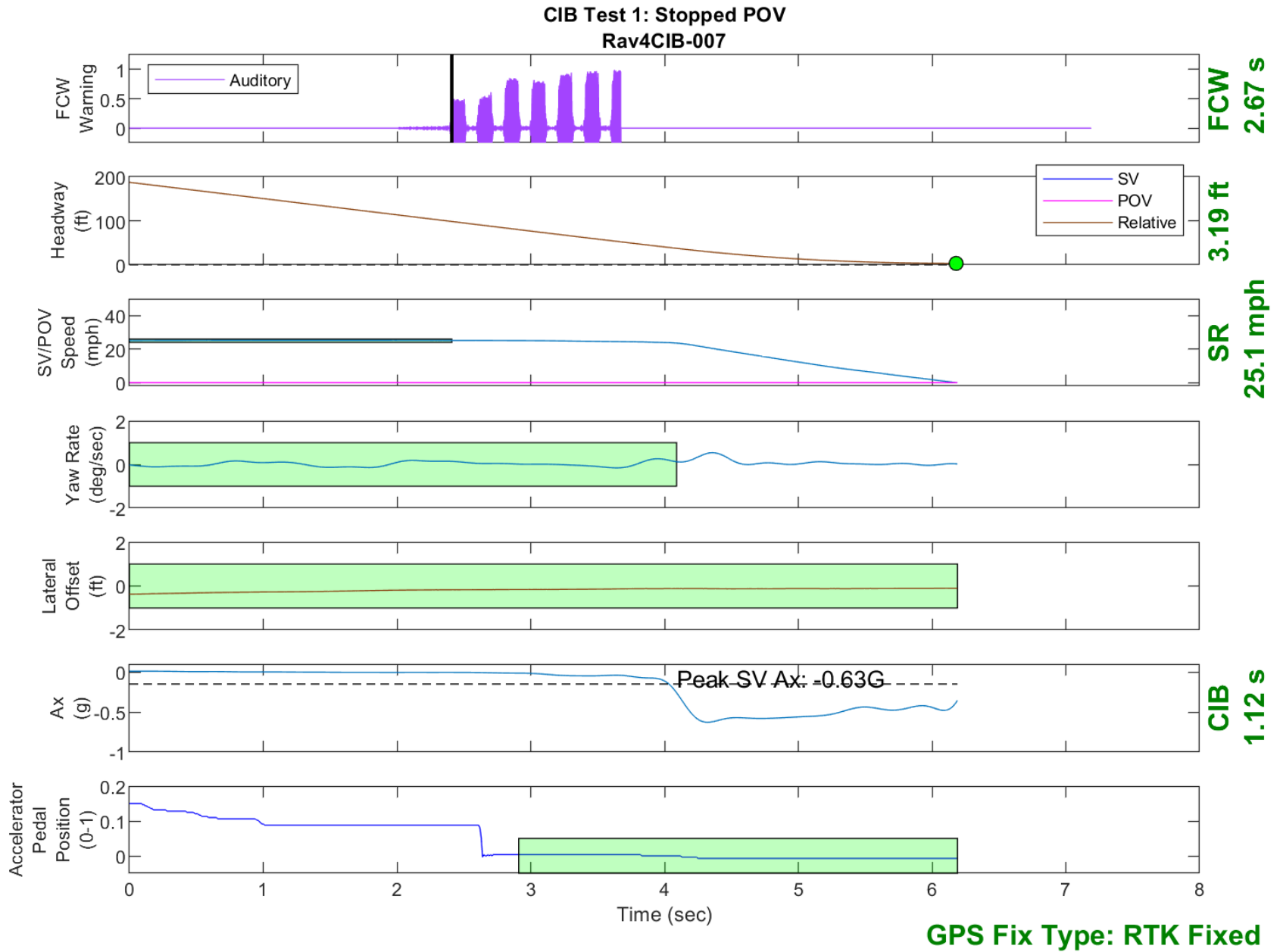

Figure D15. Time History for CIB Run 7, Test 1 - Stopped POV

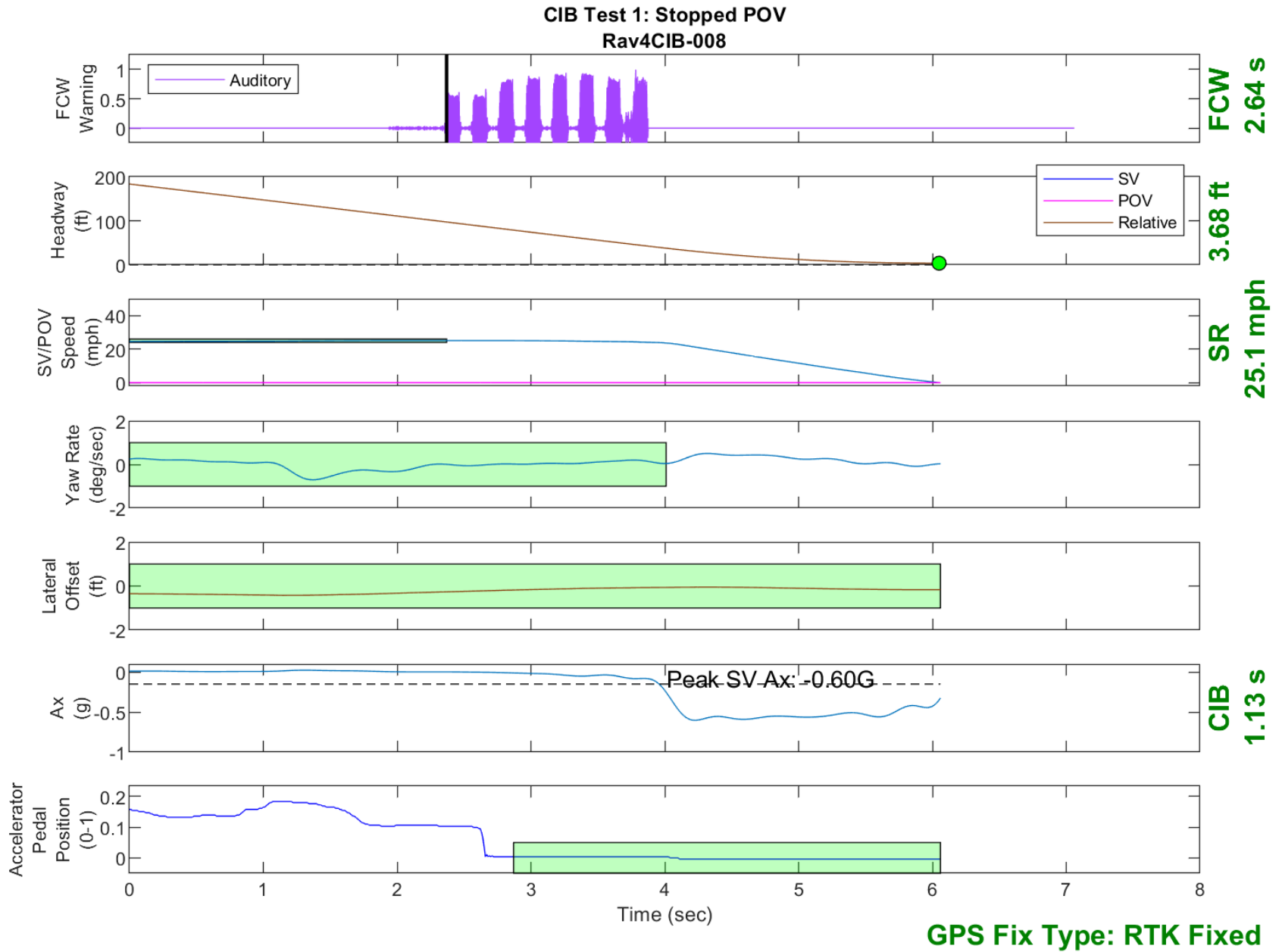

Figure D16. Time History for CIB Run 8, Test 1 - Stopped POV

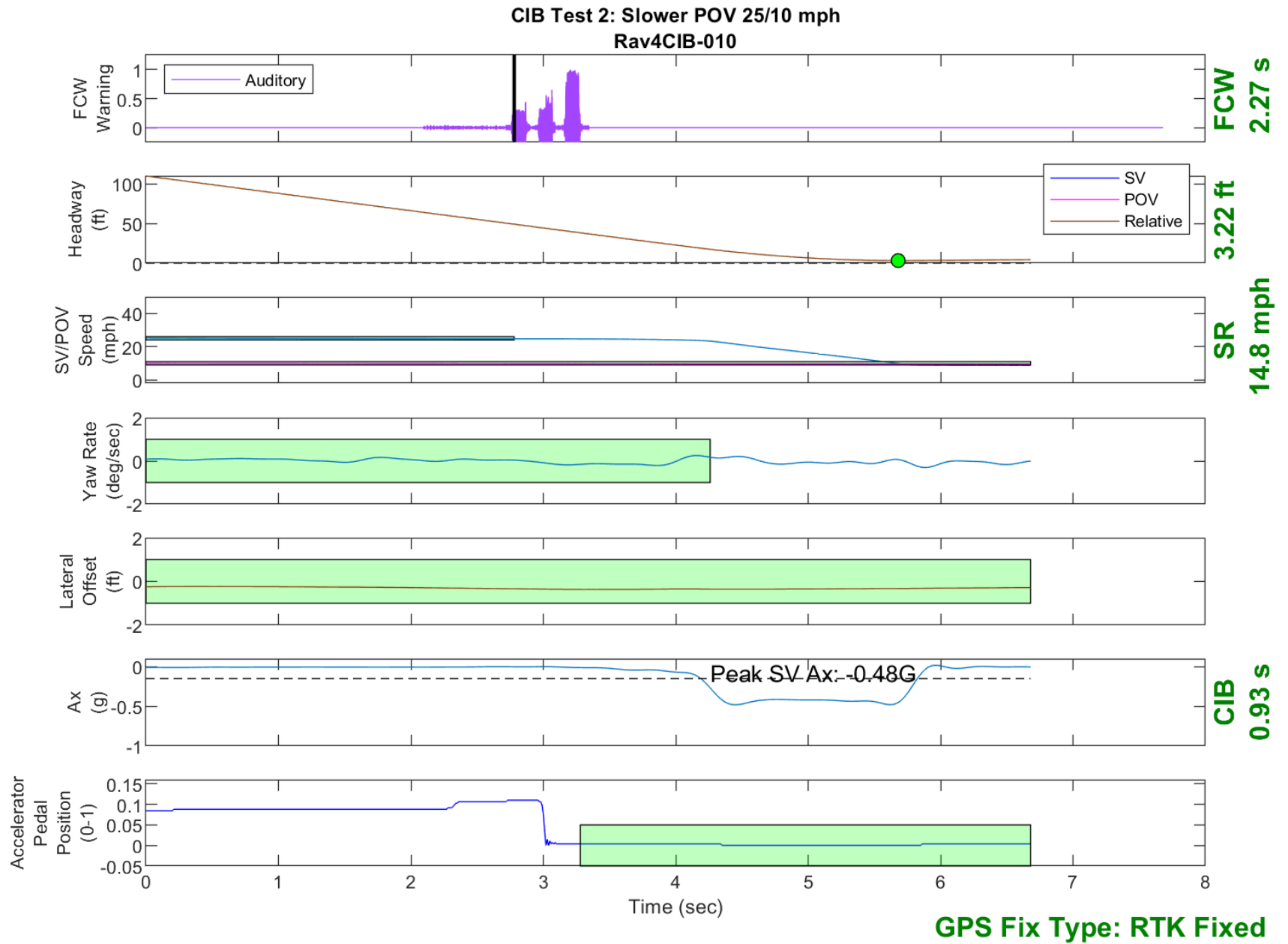

Figure D17. Time History for CIB Run 10, Test 2 - Slower Moving POV, 25/10 mph

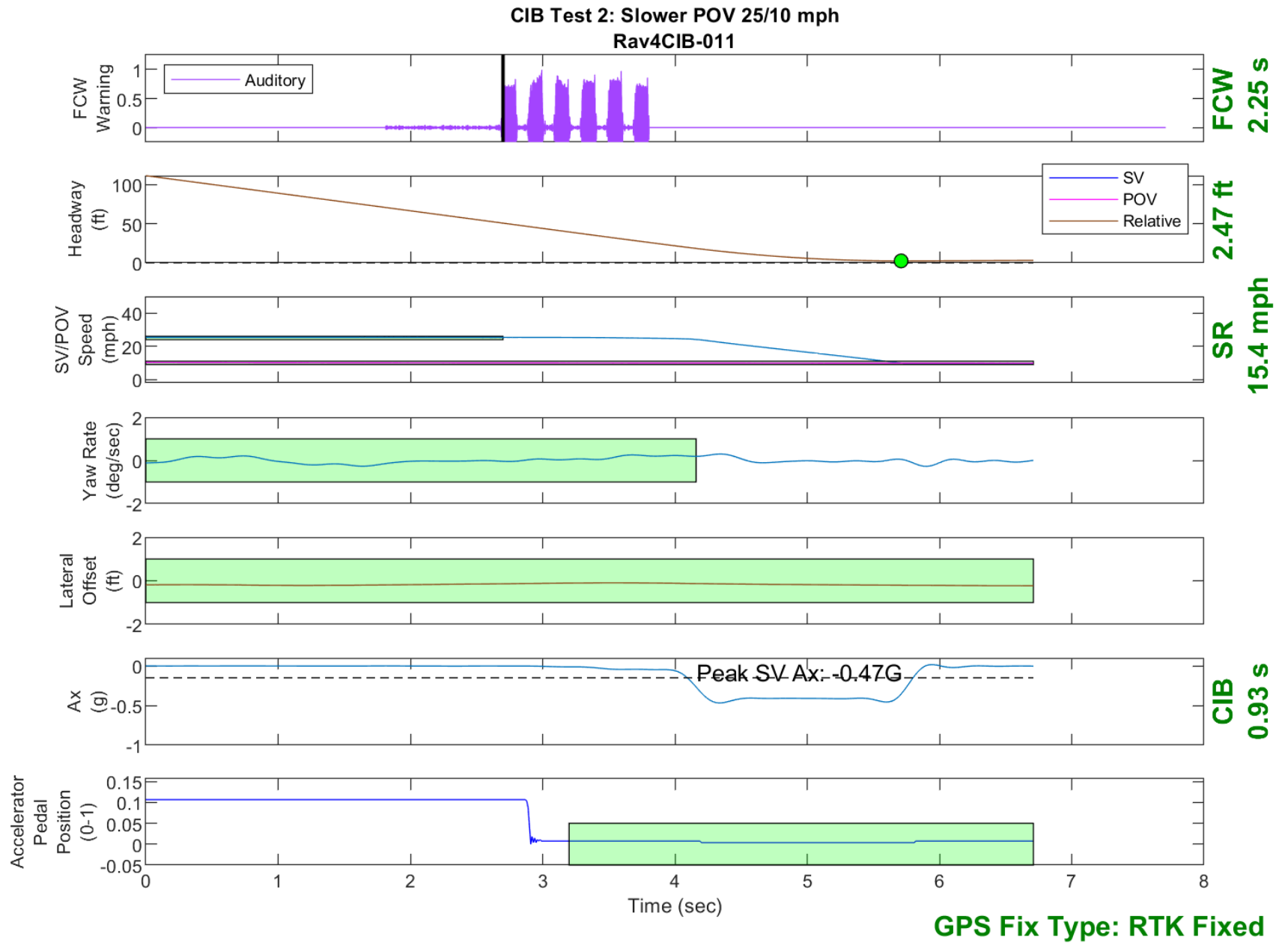

Figure D18. Time History for CIB Run 11, Test 2 - Slower Moving POV, 25/10 mph

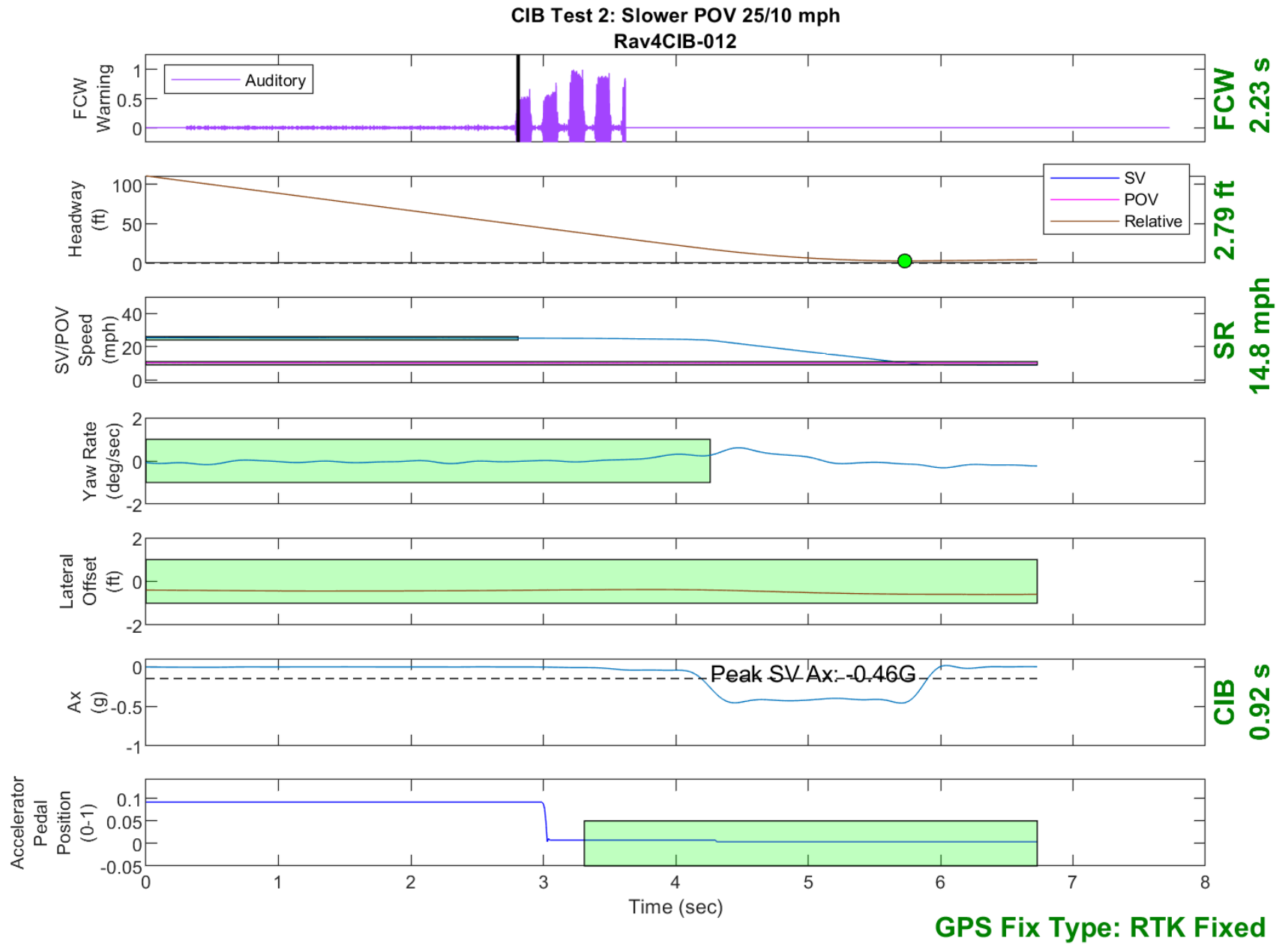

Figure D19. Time History for CIB Run 12, Test 2 - Slower Moving POV, 25/10 mph

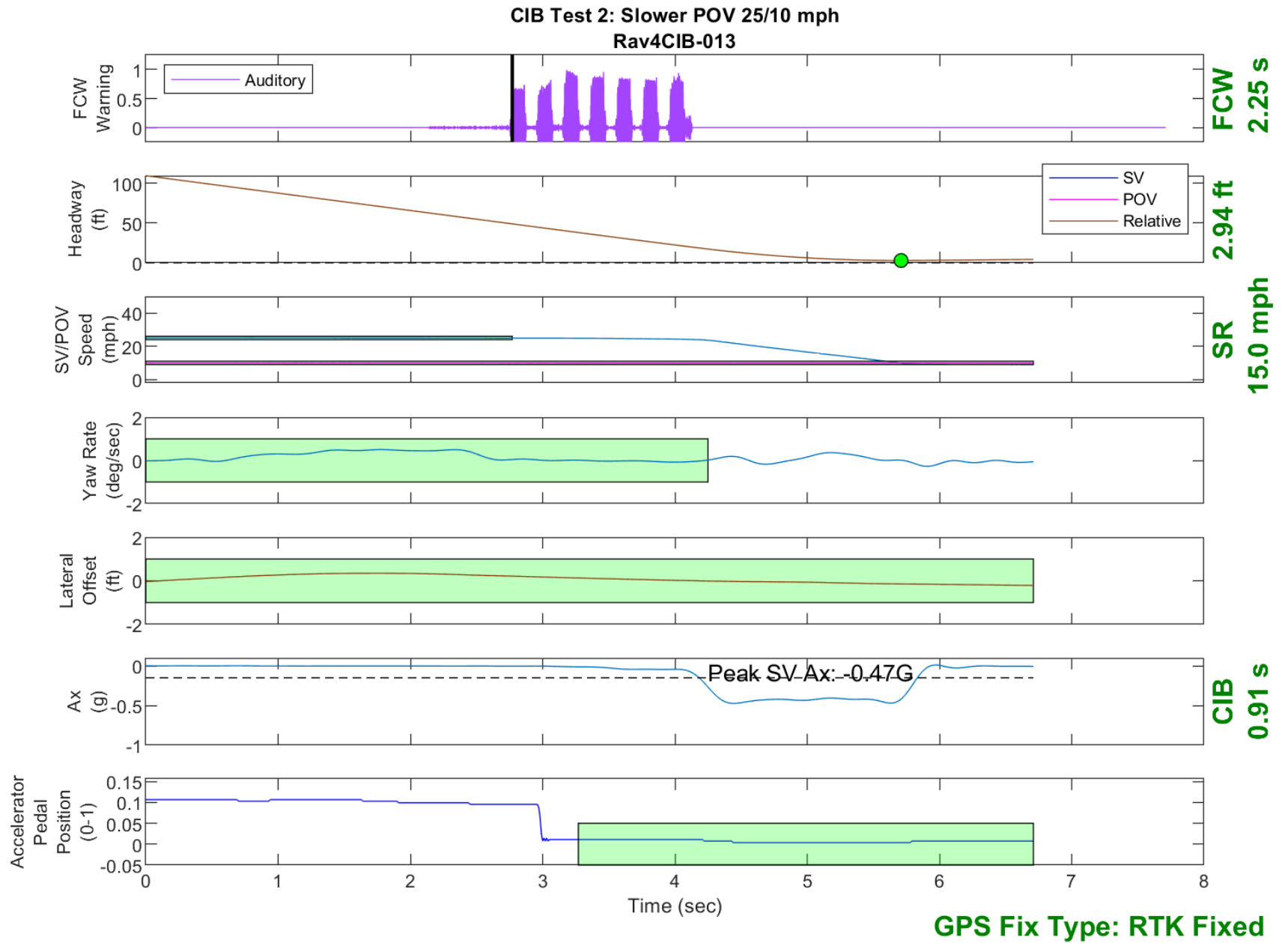

Figure D20. Time History for CIB Run 13, Test 2 - Slower Moving POV, 25/10 mph

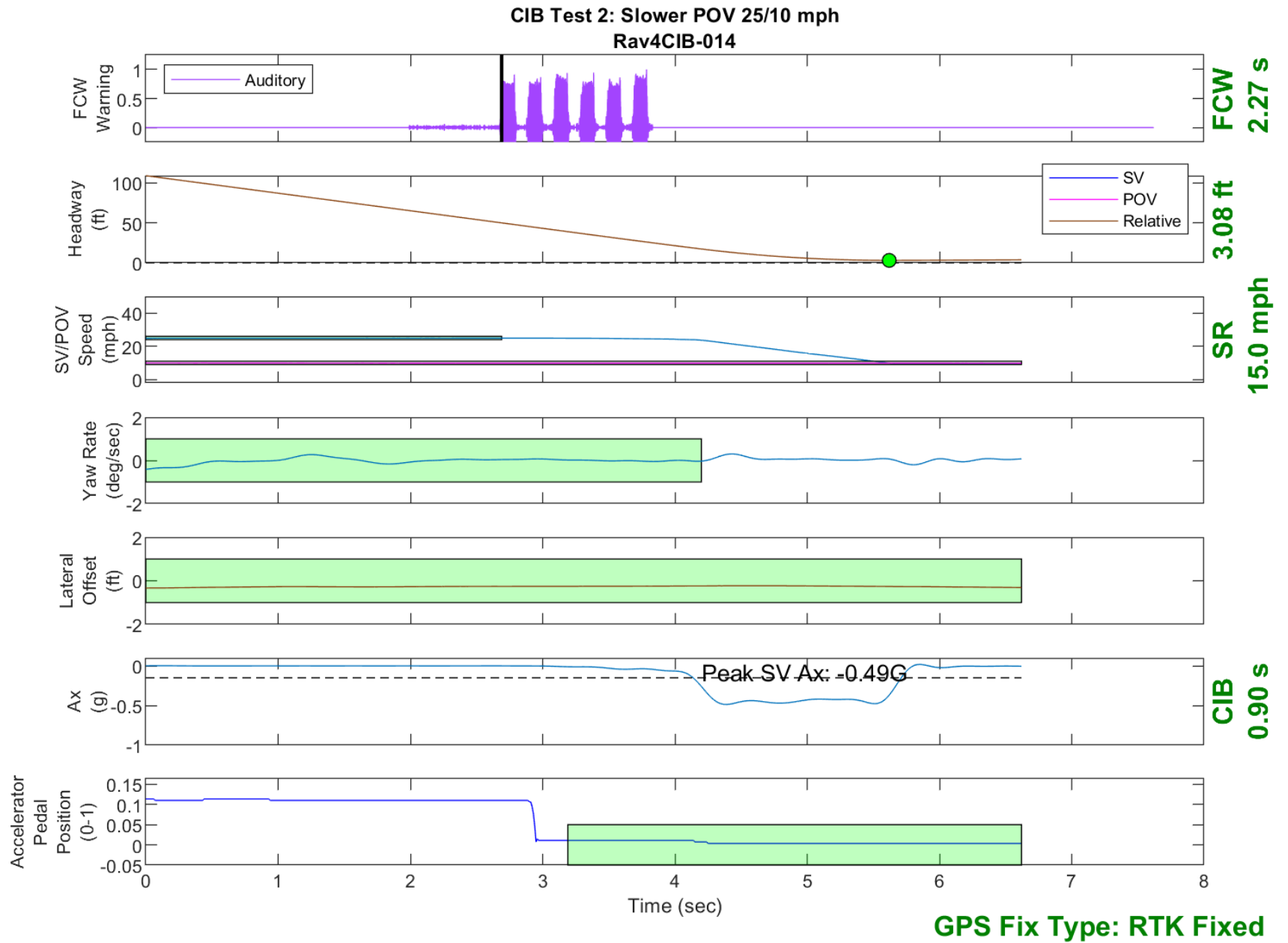

Figure D21. Time History for CIB Run 14, Test 2 - Slower Moving POV, 25/10 mph

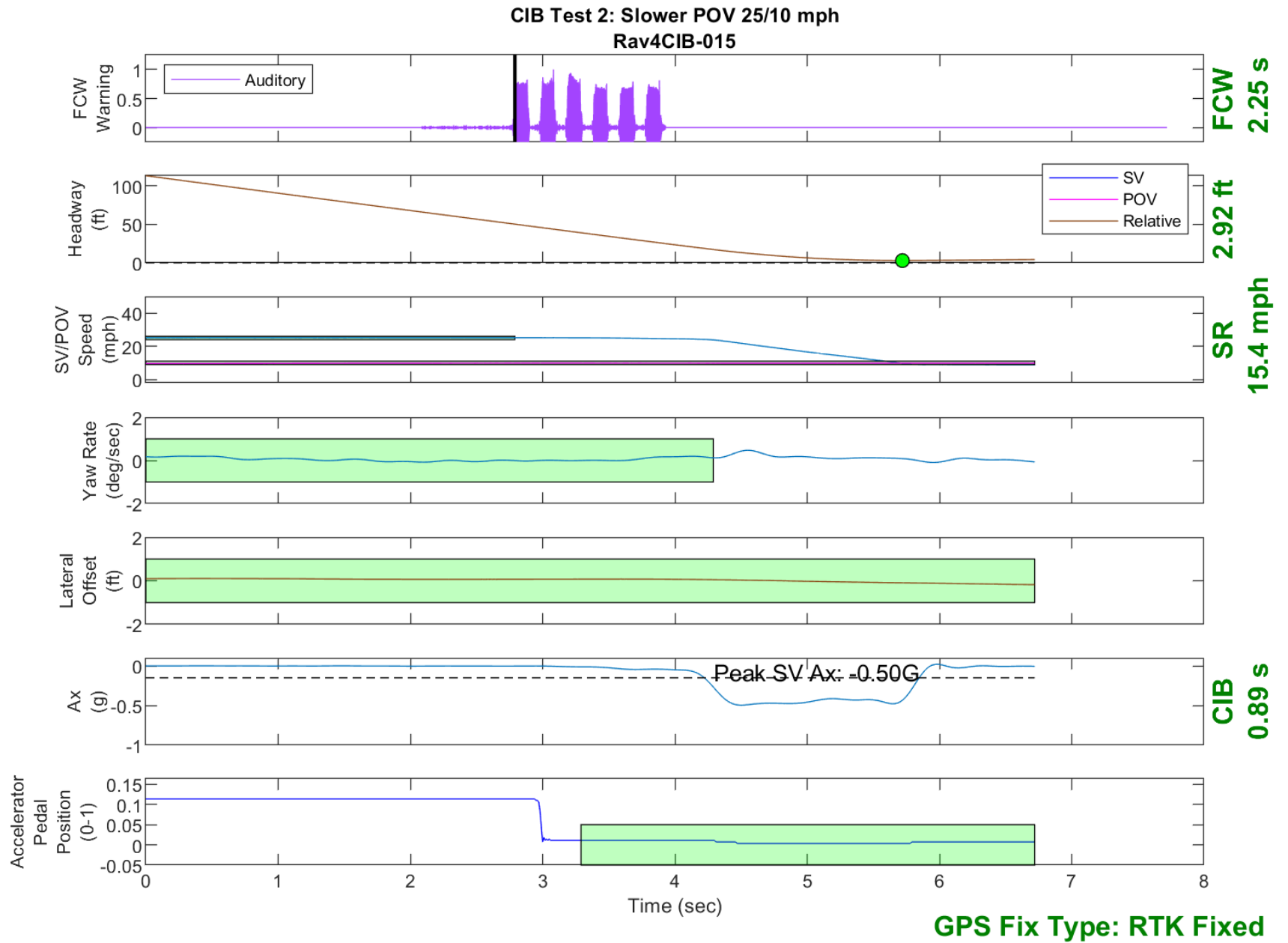

Figure D22. Time History for CIB Run 15, Test 2 - Slower Moving POV, 25/10 mph

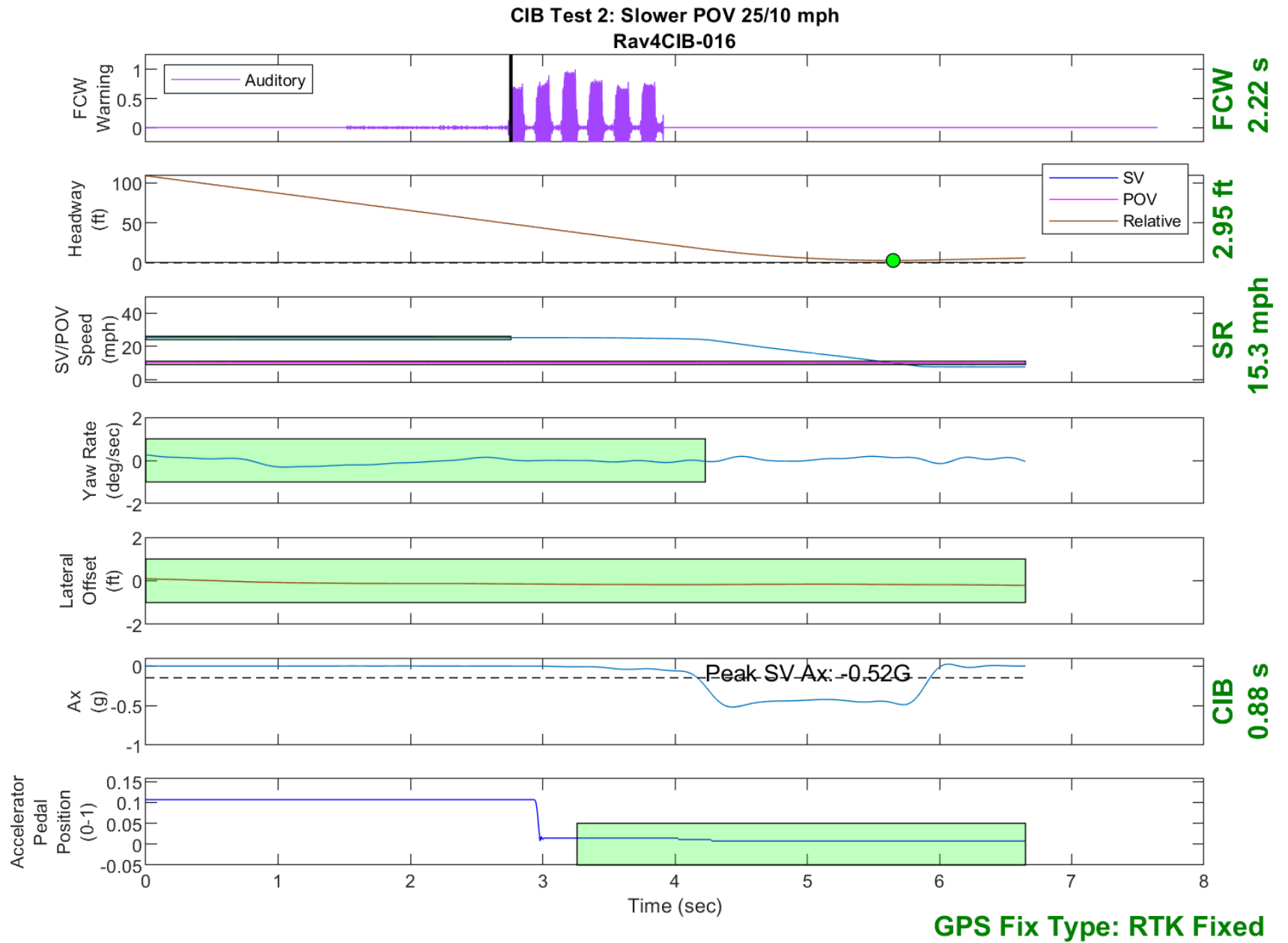

Figure D23. Time History for CIB Run 16, Test 2 - Slower Moving POV, 25/10 mph

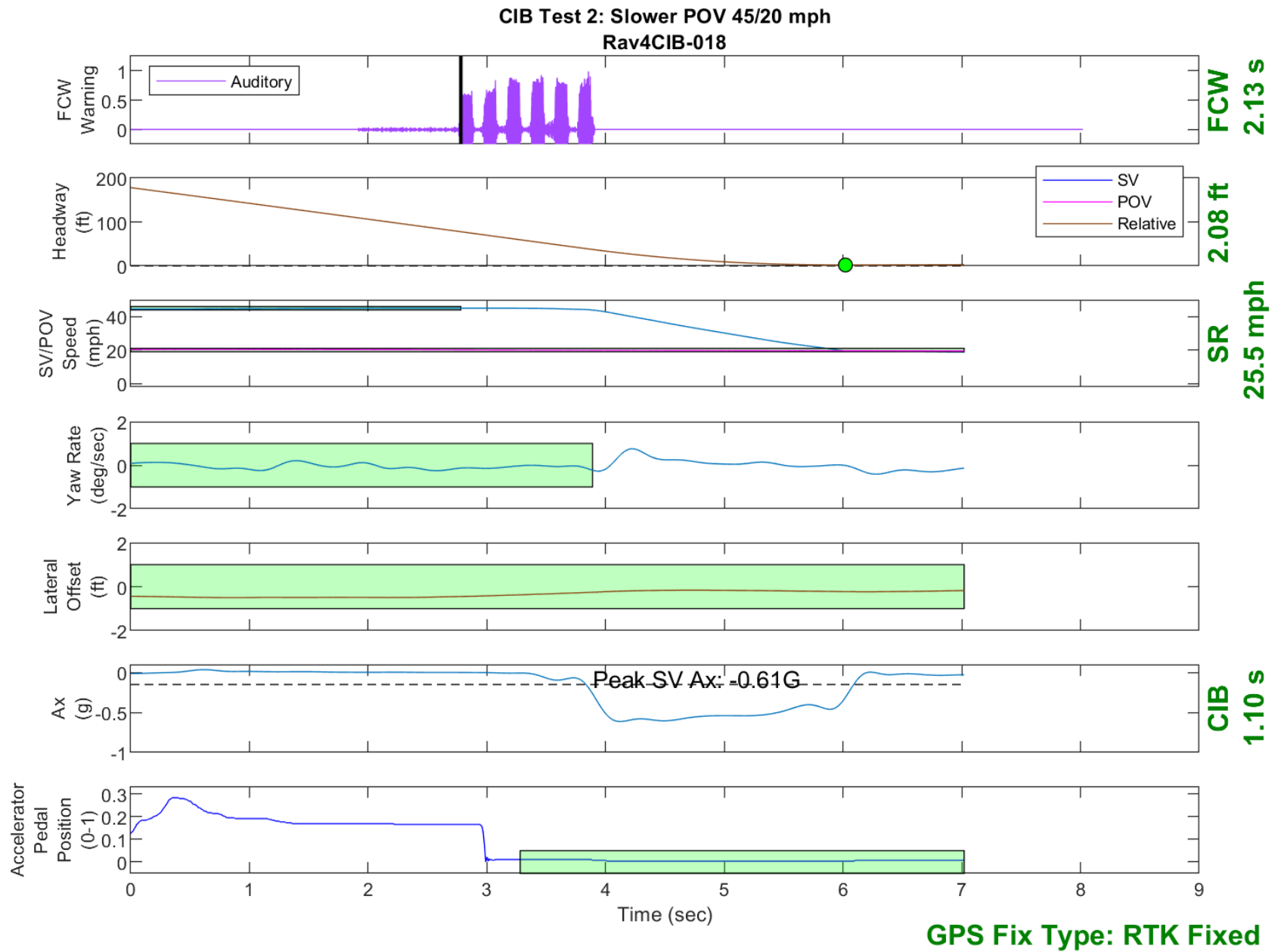

Figure D24. Time History for CIB Run 18, Test 2 - Slower Moving POV, 45/20 mph

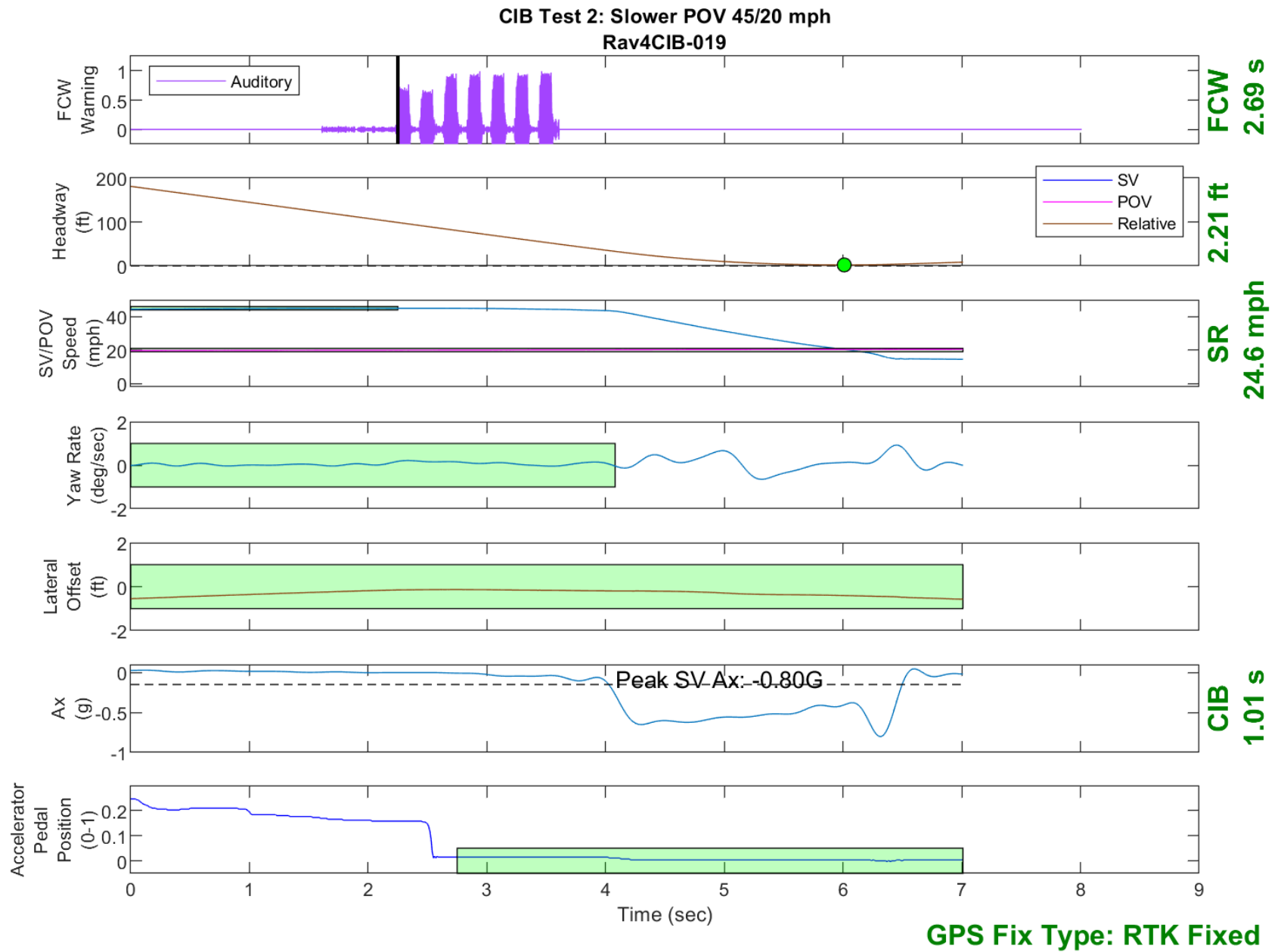

Figure D25. Time History for CIB Run 19, Test 2 - Slower Moving POV, 45/20 mph

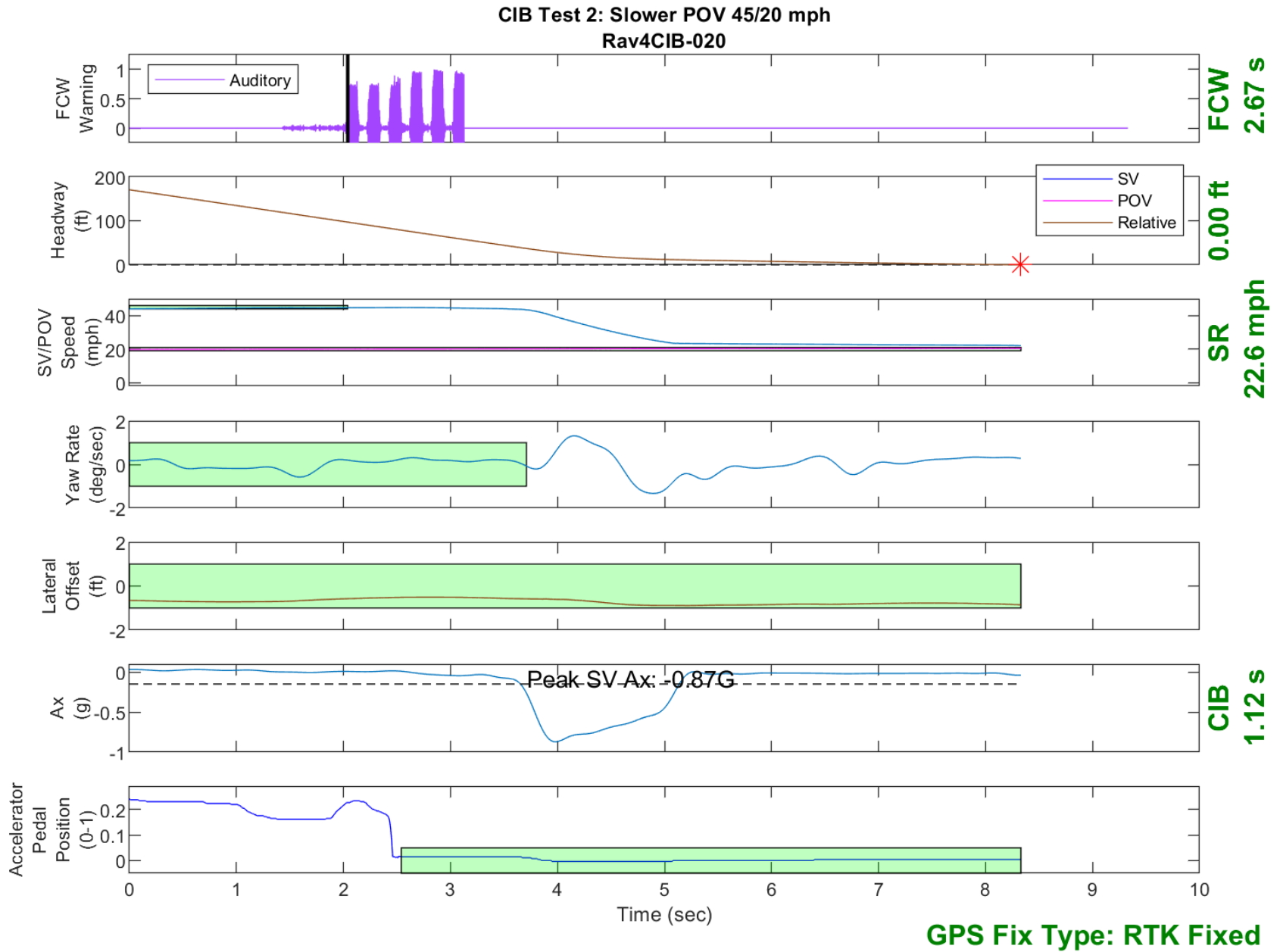

Figure D26. Time History for CIB Run 20, Test 2 - Slower Moving POV, 45/20 mph

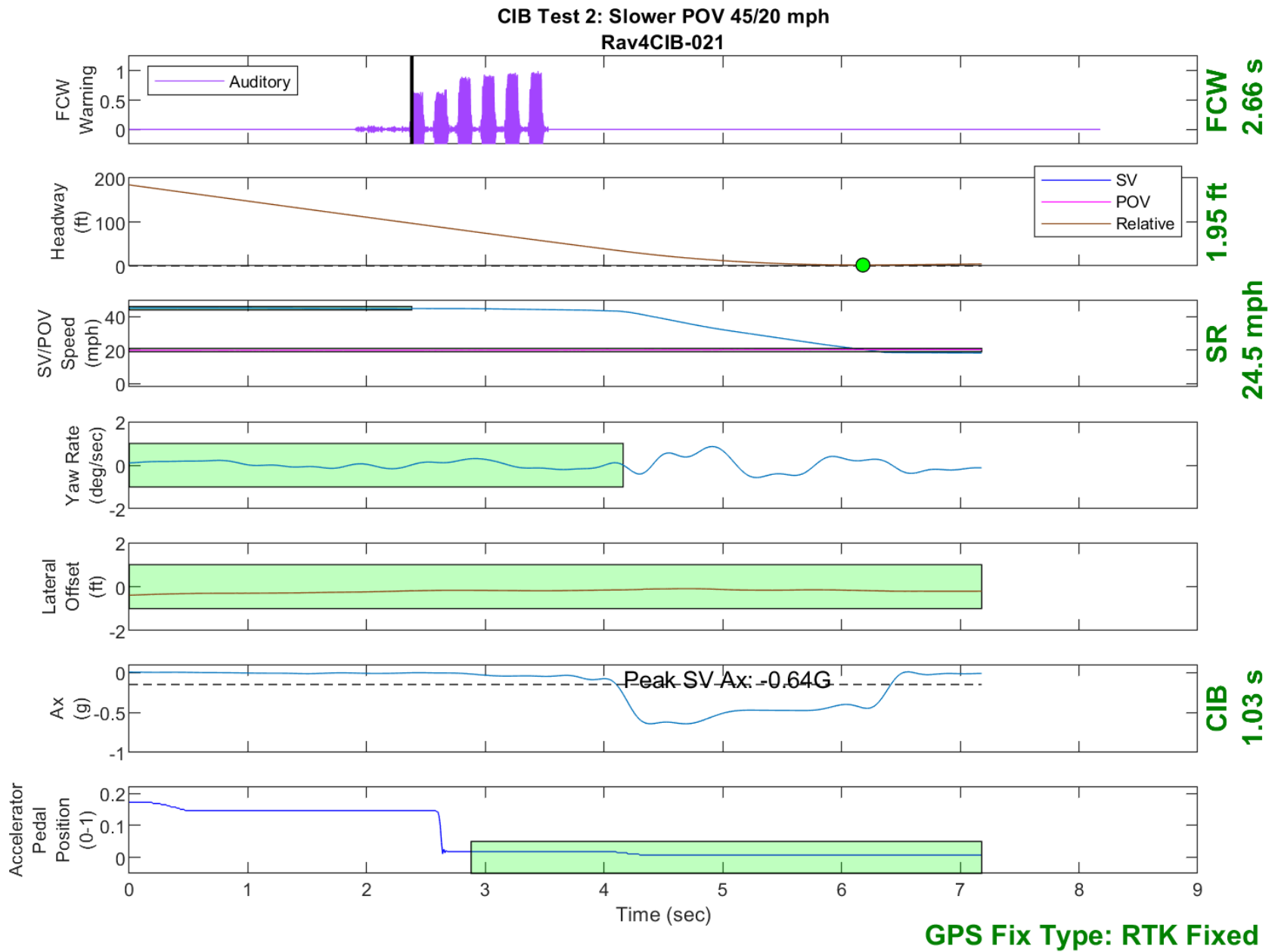

Figure D27. Time History for CIB Run 21, Test 2 - Slower Moving POV, 45/20 mph

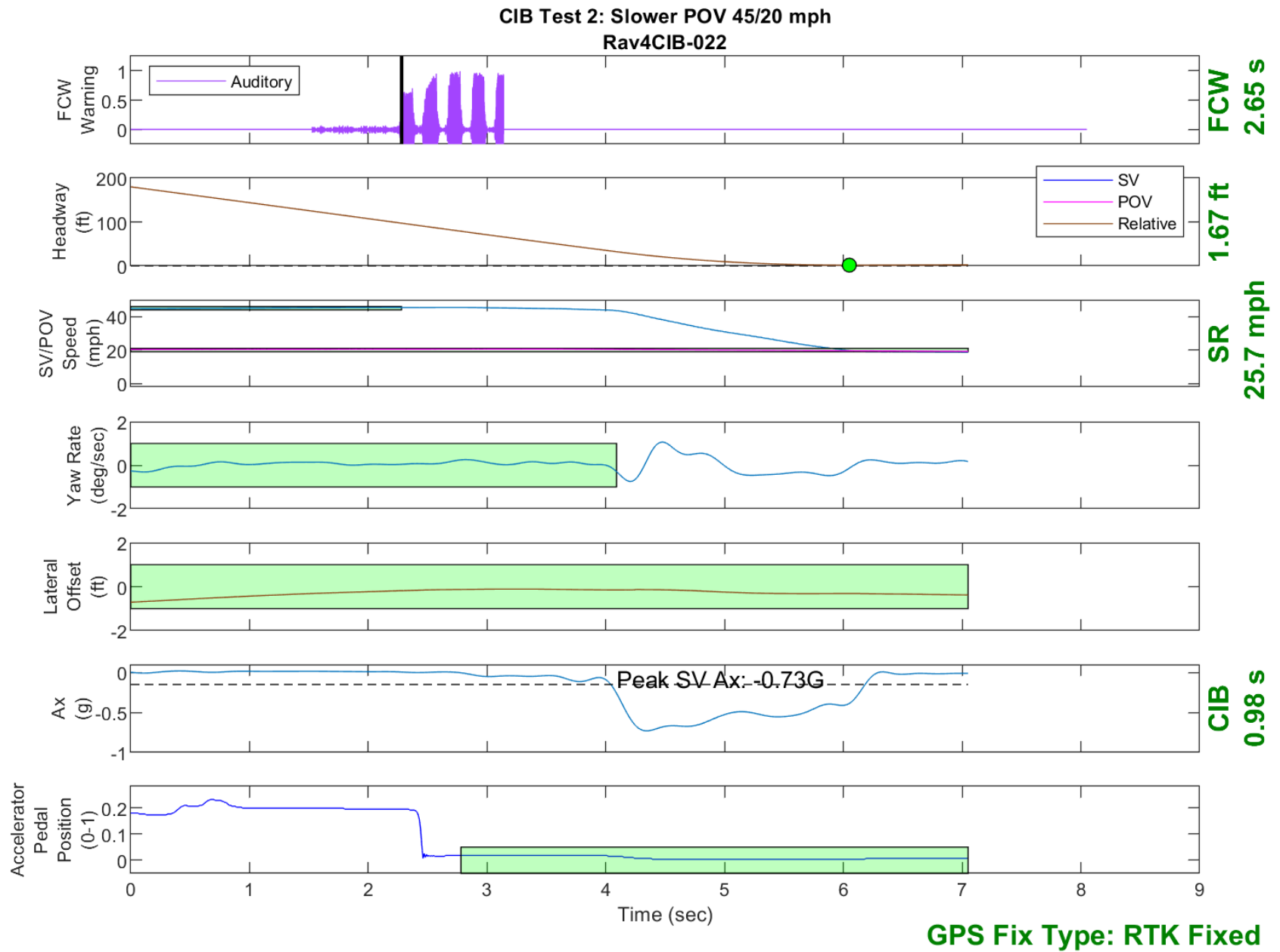

Figure D28. Time History for CIB Run 22, Test 2 - Slower Moving POV, 45/20 mph

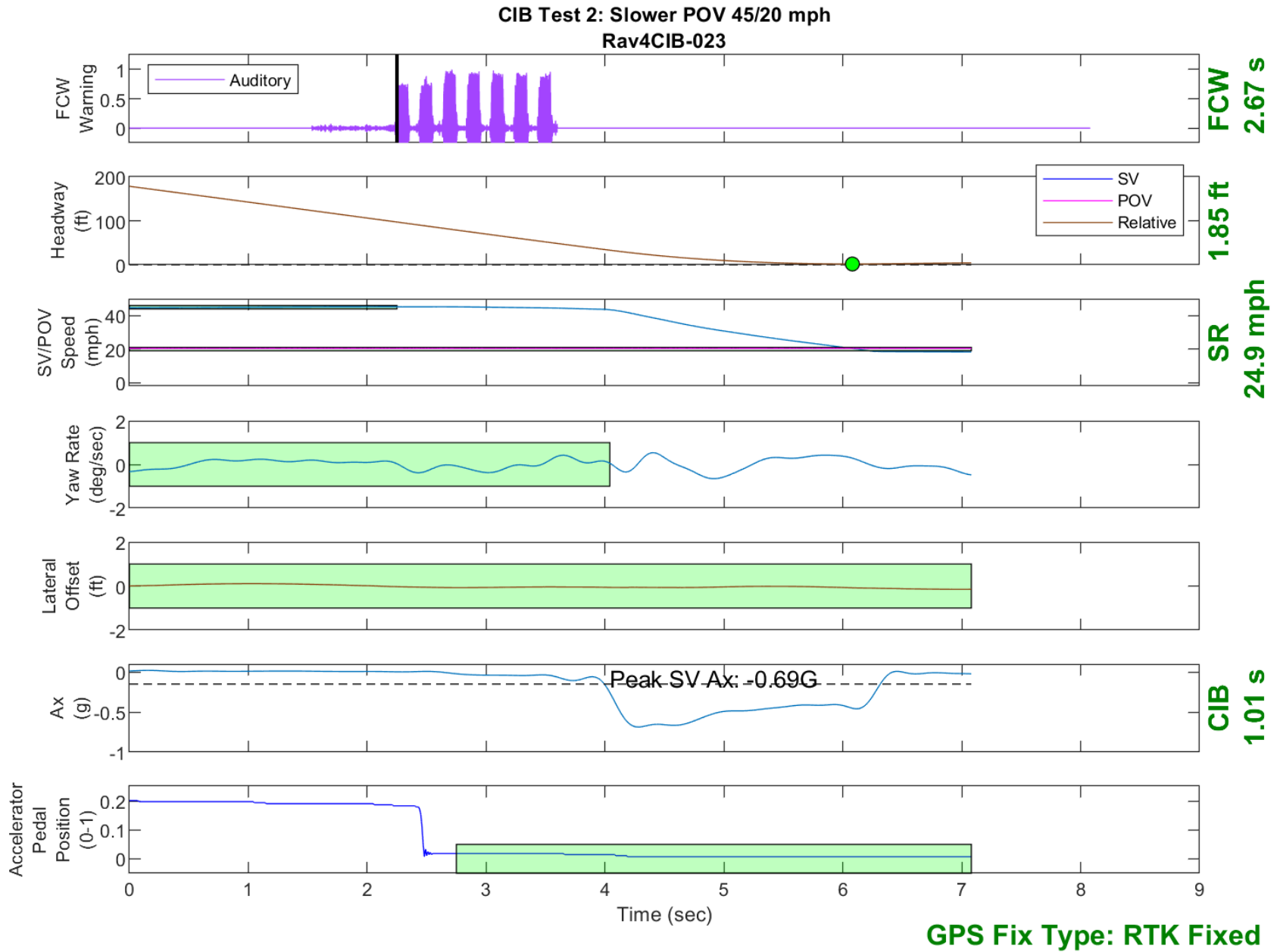

Figure D29. Time History for CIB Run 23, Test 2 - Slower Moving POV, 45/20 mph

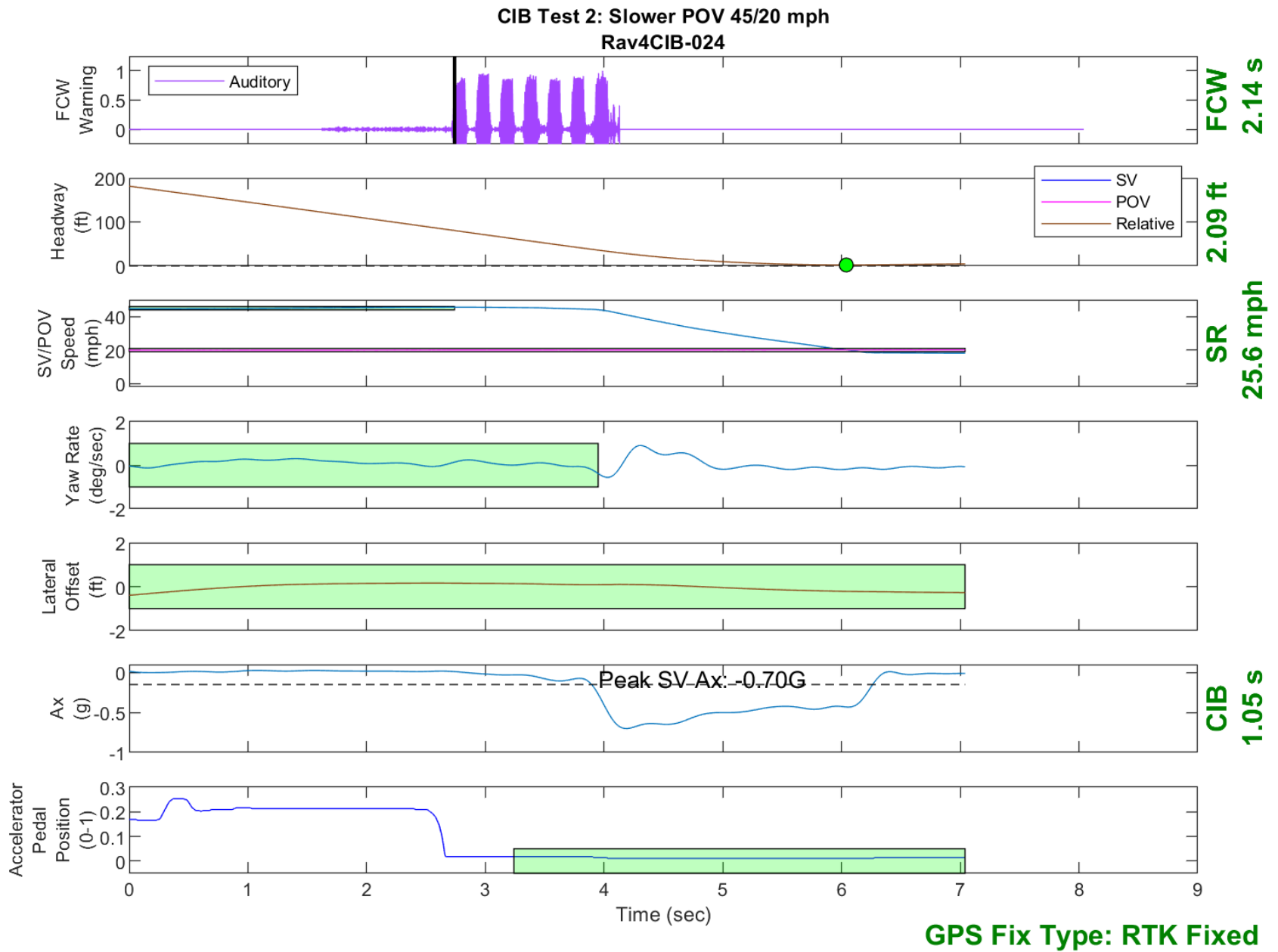

Figure D30. Time History for CIB Run 24, Test 2 - Slower Moving POV, 45/20 mph

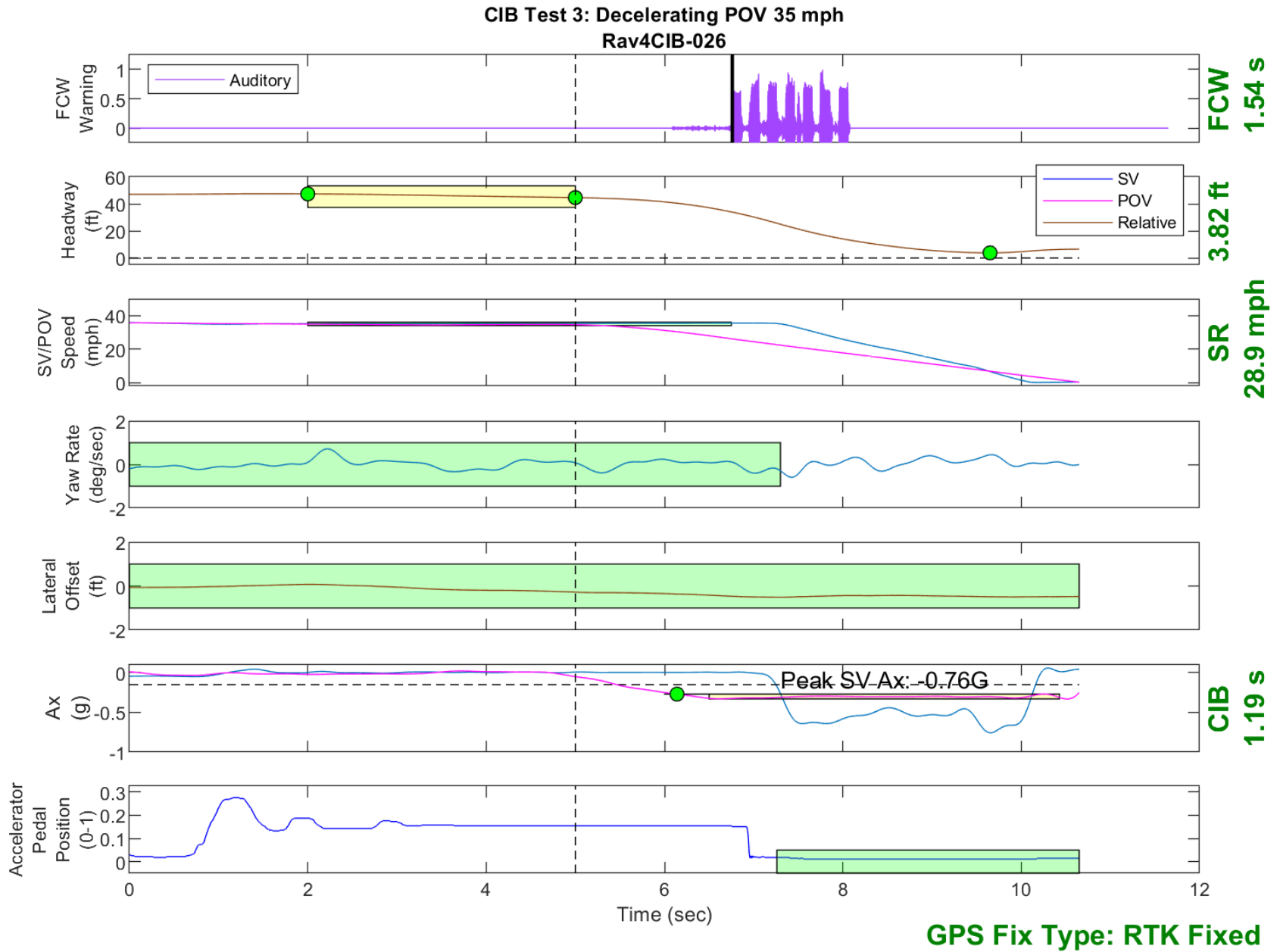

Figure D31. Time History for CIB Run 26, Test 3 - Decelerating POV 35 mph

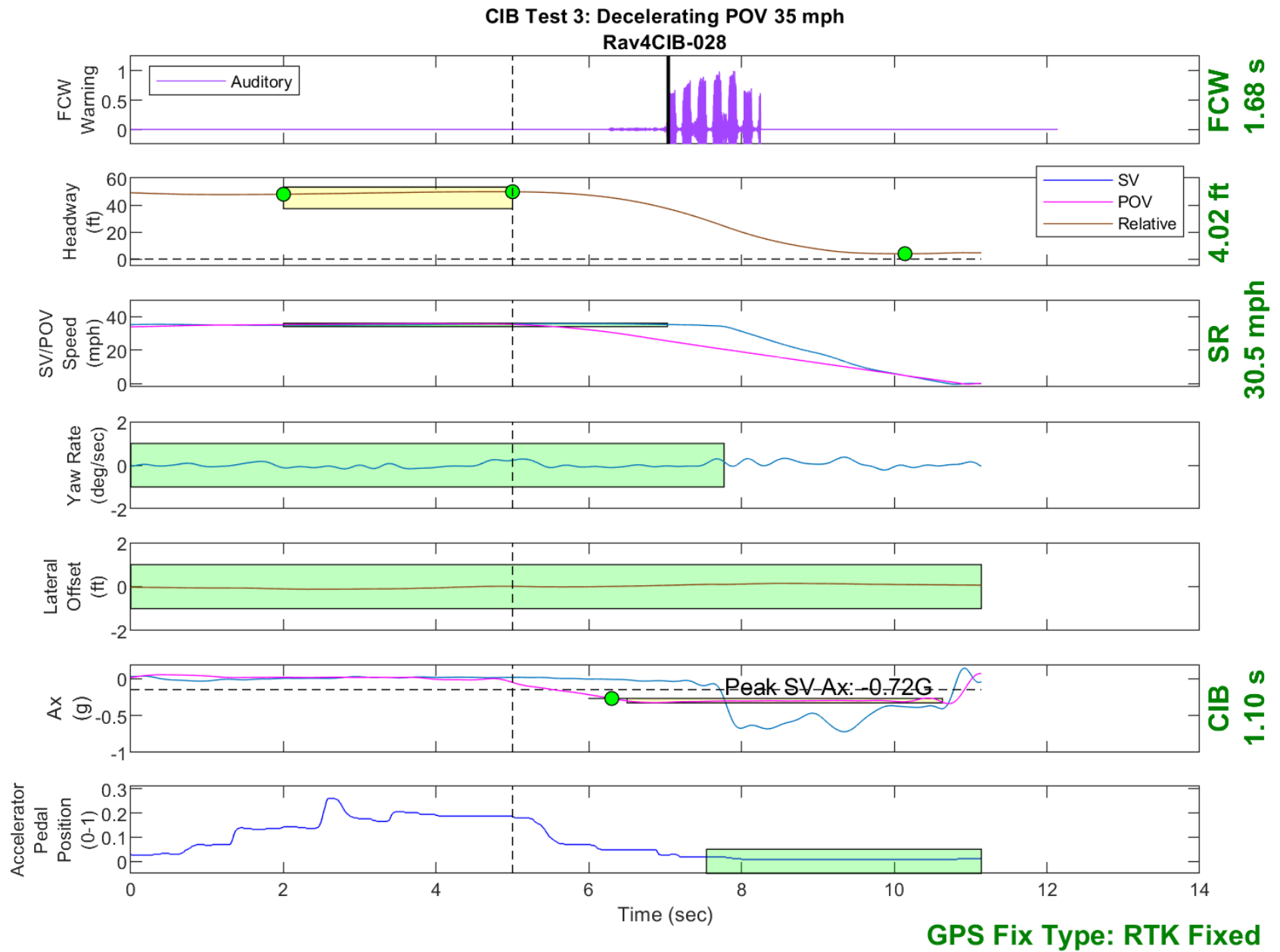

Figure D32. Time History for CIB Run 28, Test 3 - Decelerating POV 35 mph

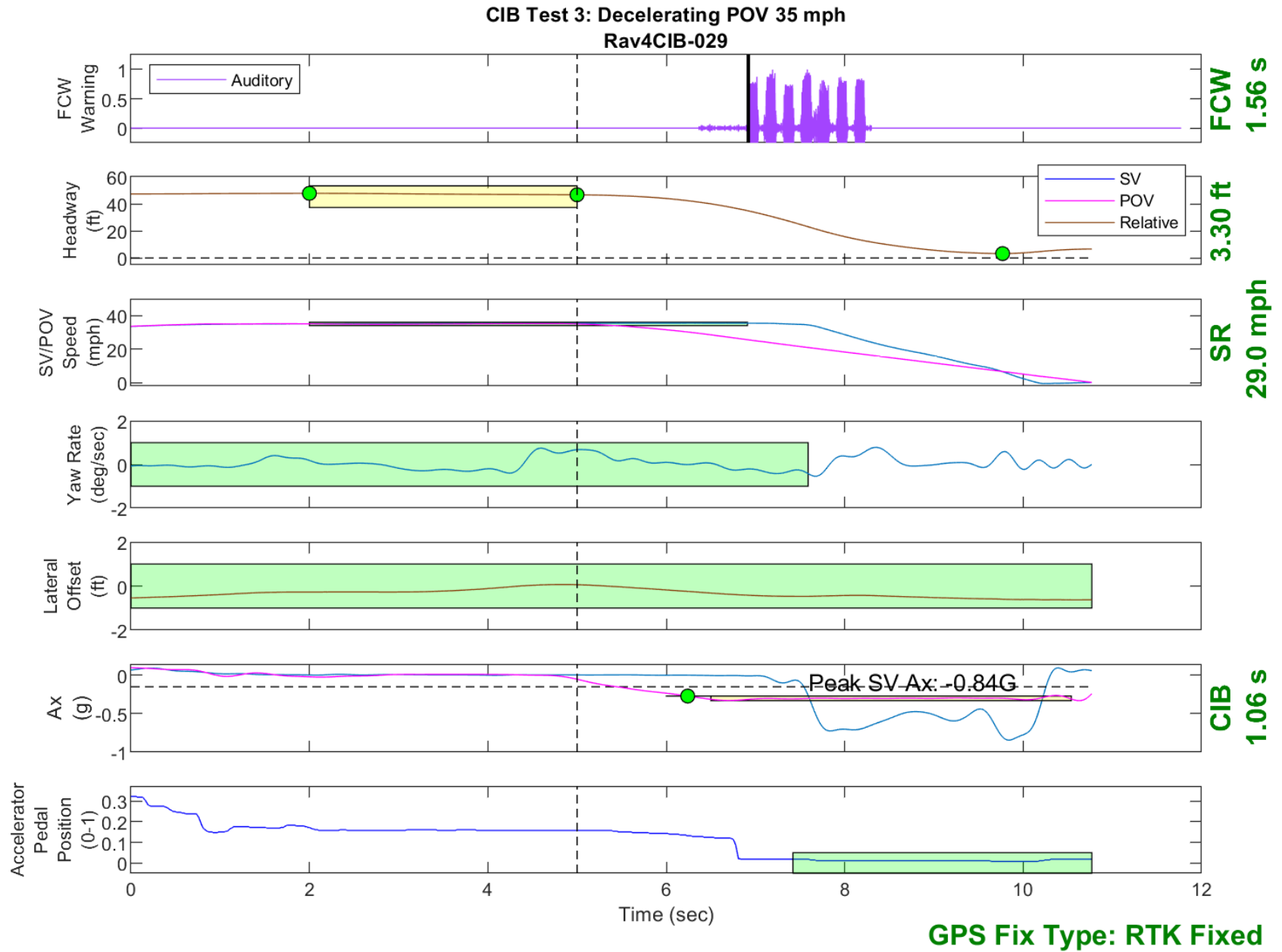

Figure D33. Time History for CIB Run 29, Test 3 - Decelerating POV 35 mph

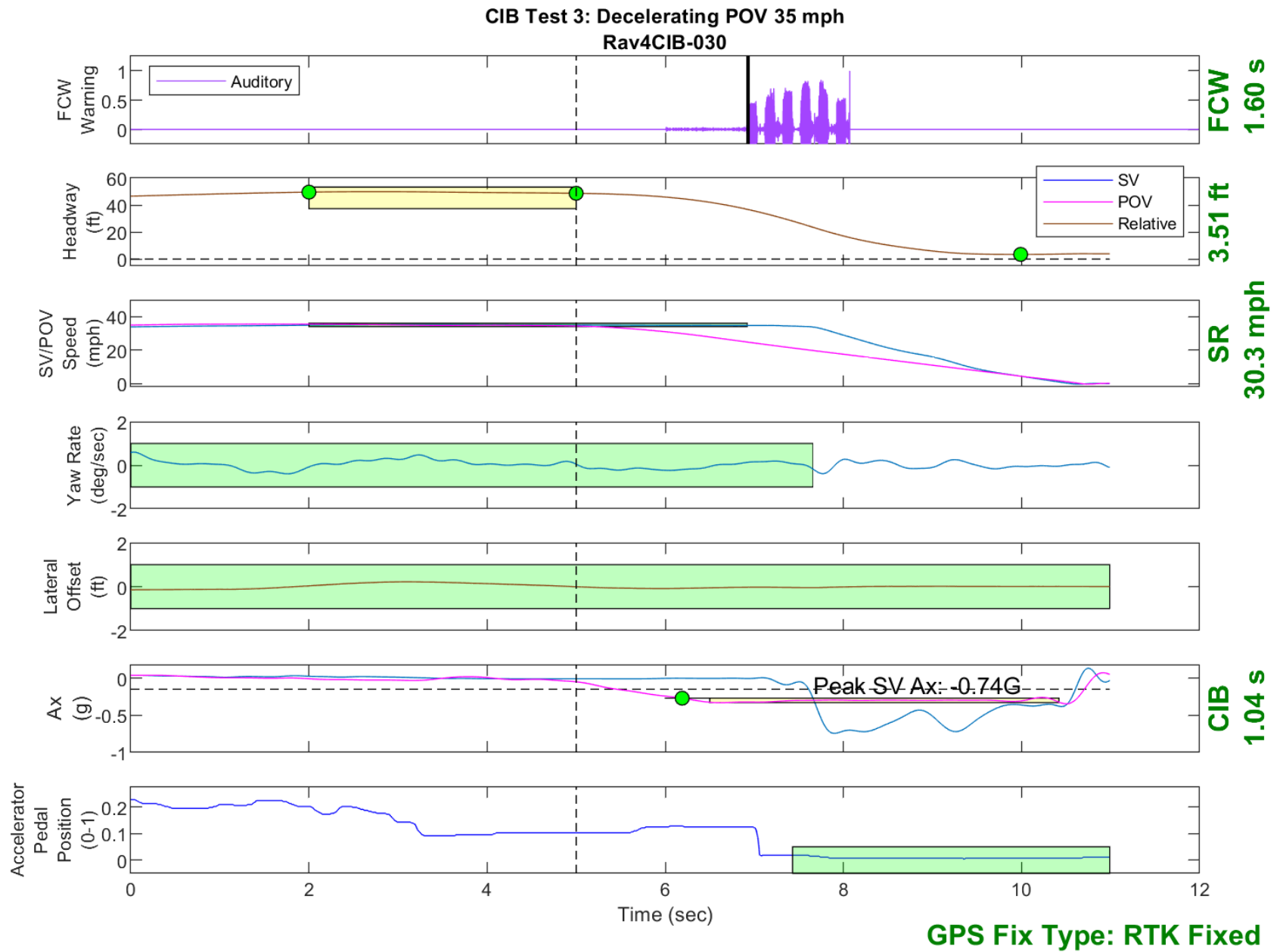

Figure D34. Time History for CIB Run 30, Test 3 - Decelerating POV 35 mph

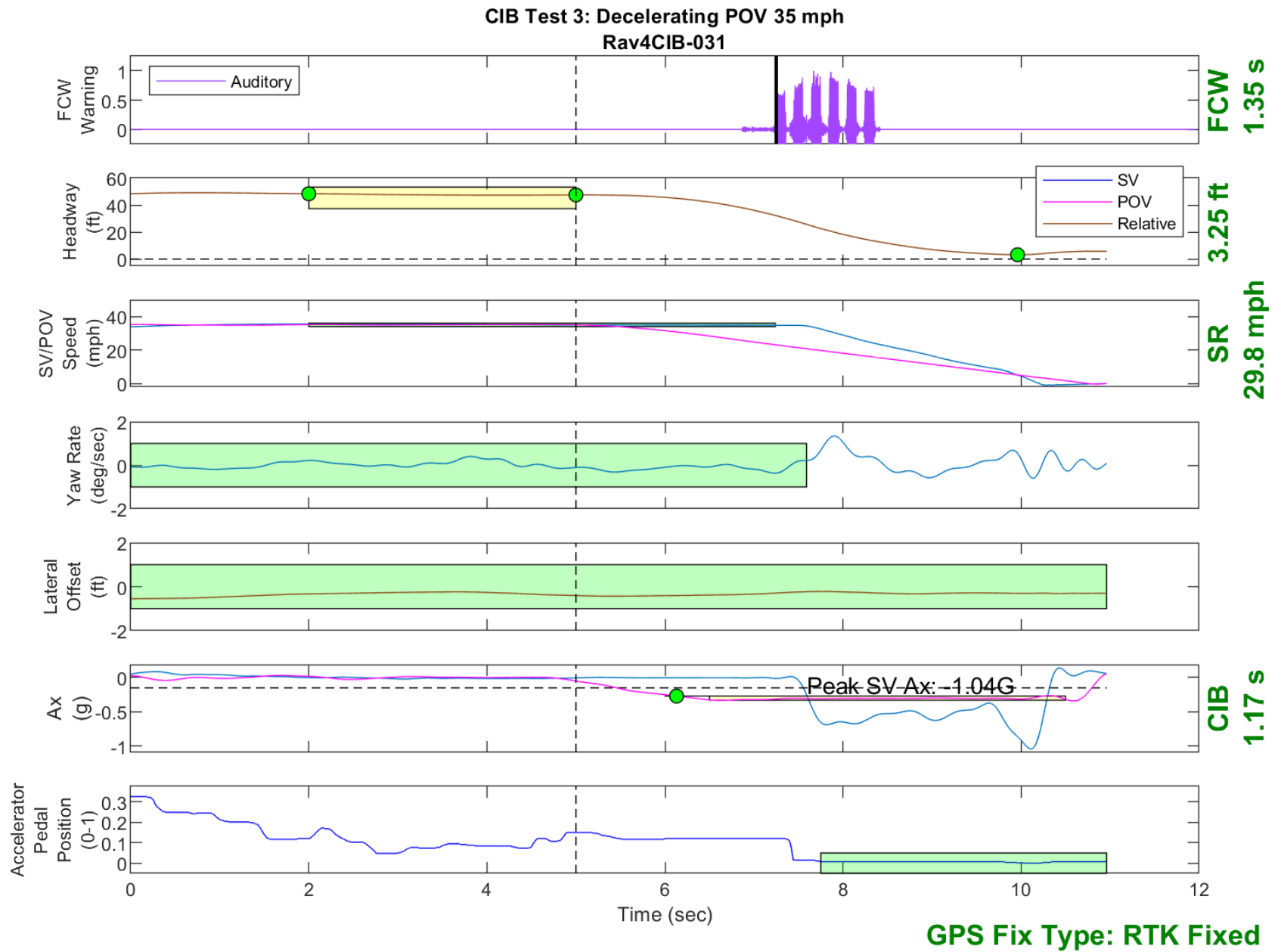

Figure D35. Time History for CIB Run 31, Test 3 - Decelerating POV 35 mph

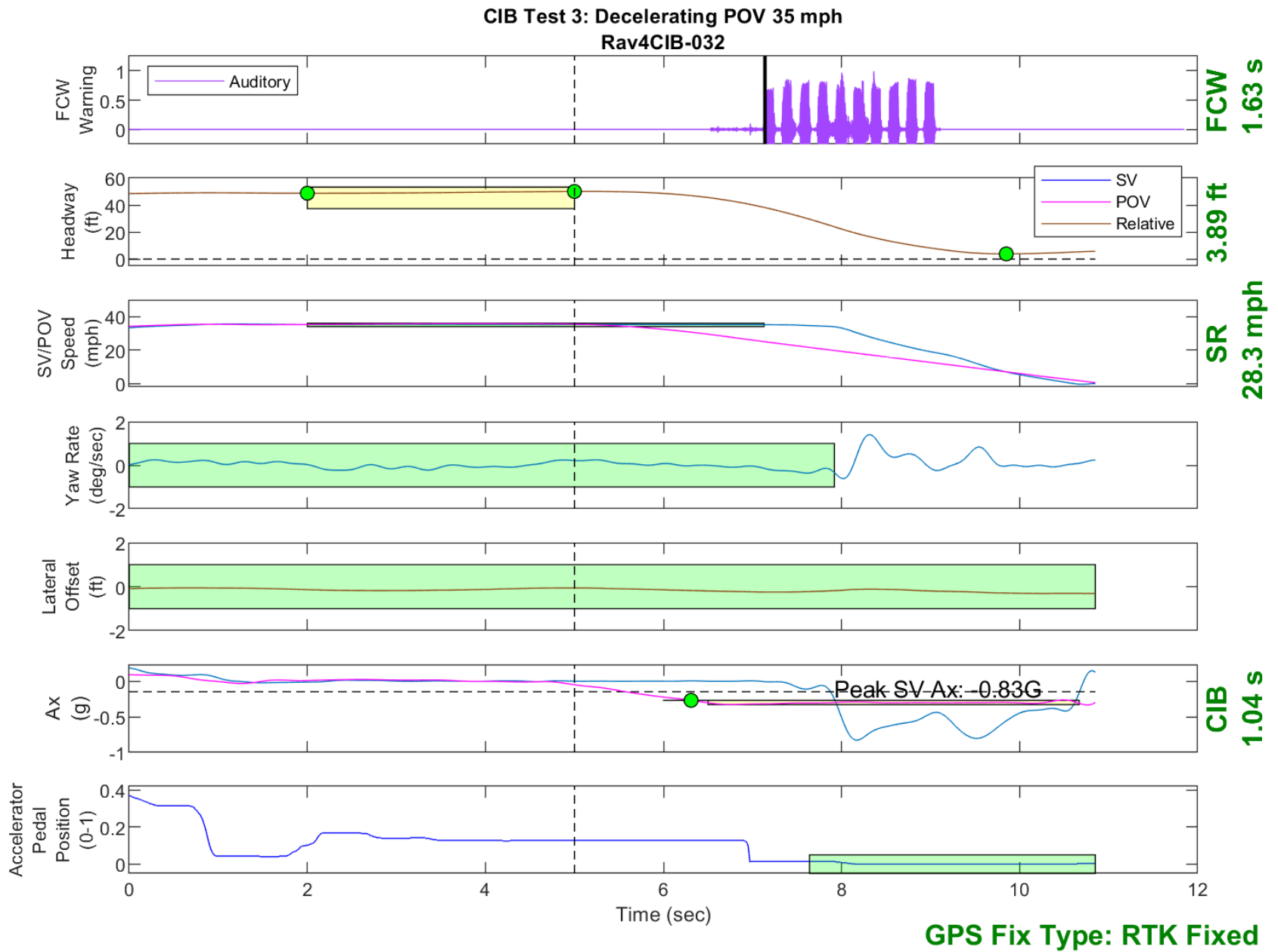

Figure D36. Time History for CIB Run 32, Test 3 - Decelerating POV 35 mph



Figure D37. Time History for CIB Run 33, Test 3 - Decelerating POV 35 mph

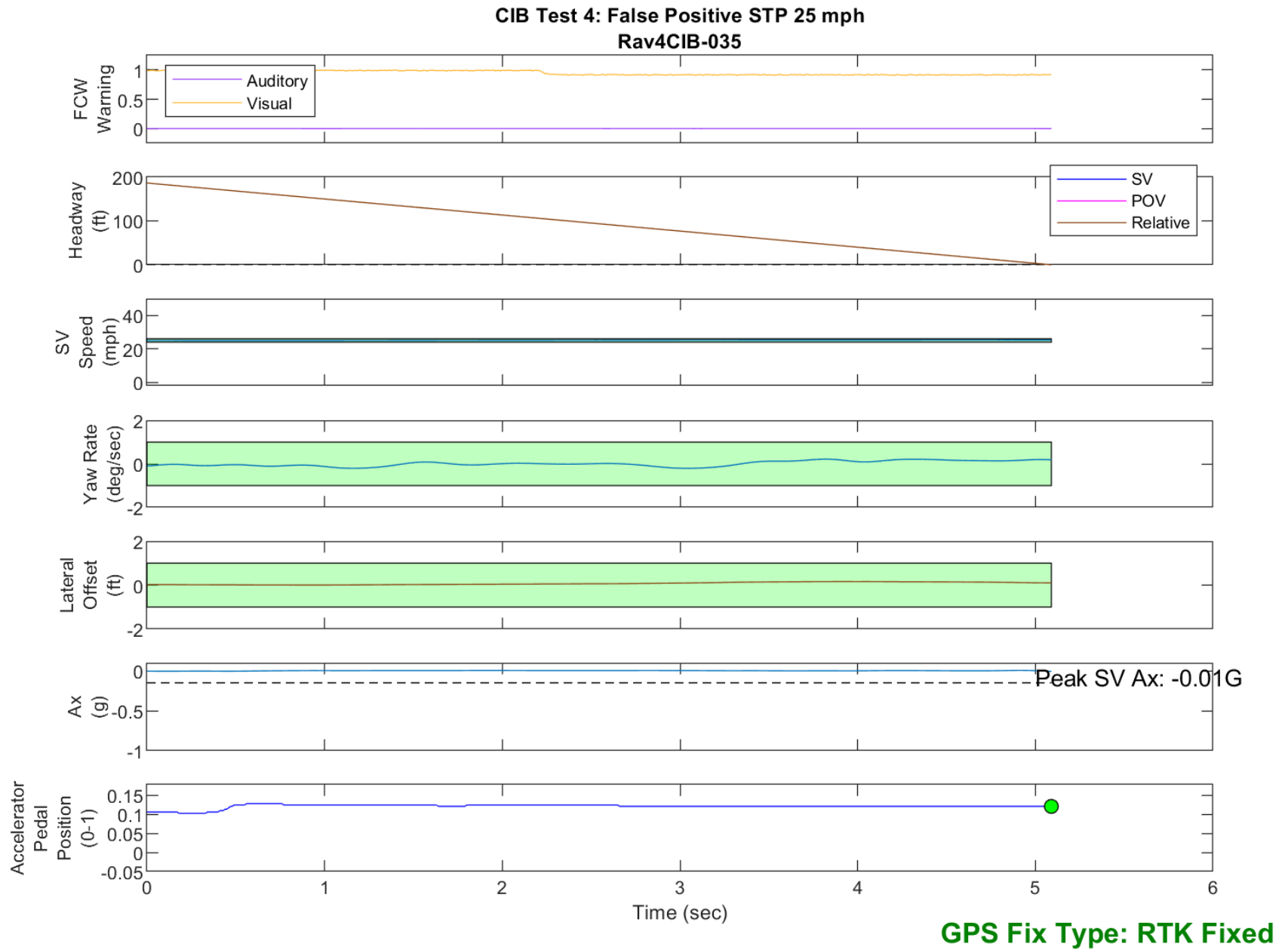

Figure D38. Time History for CIB Run 35, Test 4 - False Positive STP, 25 mph

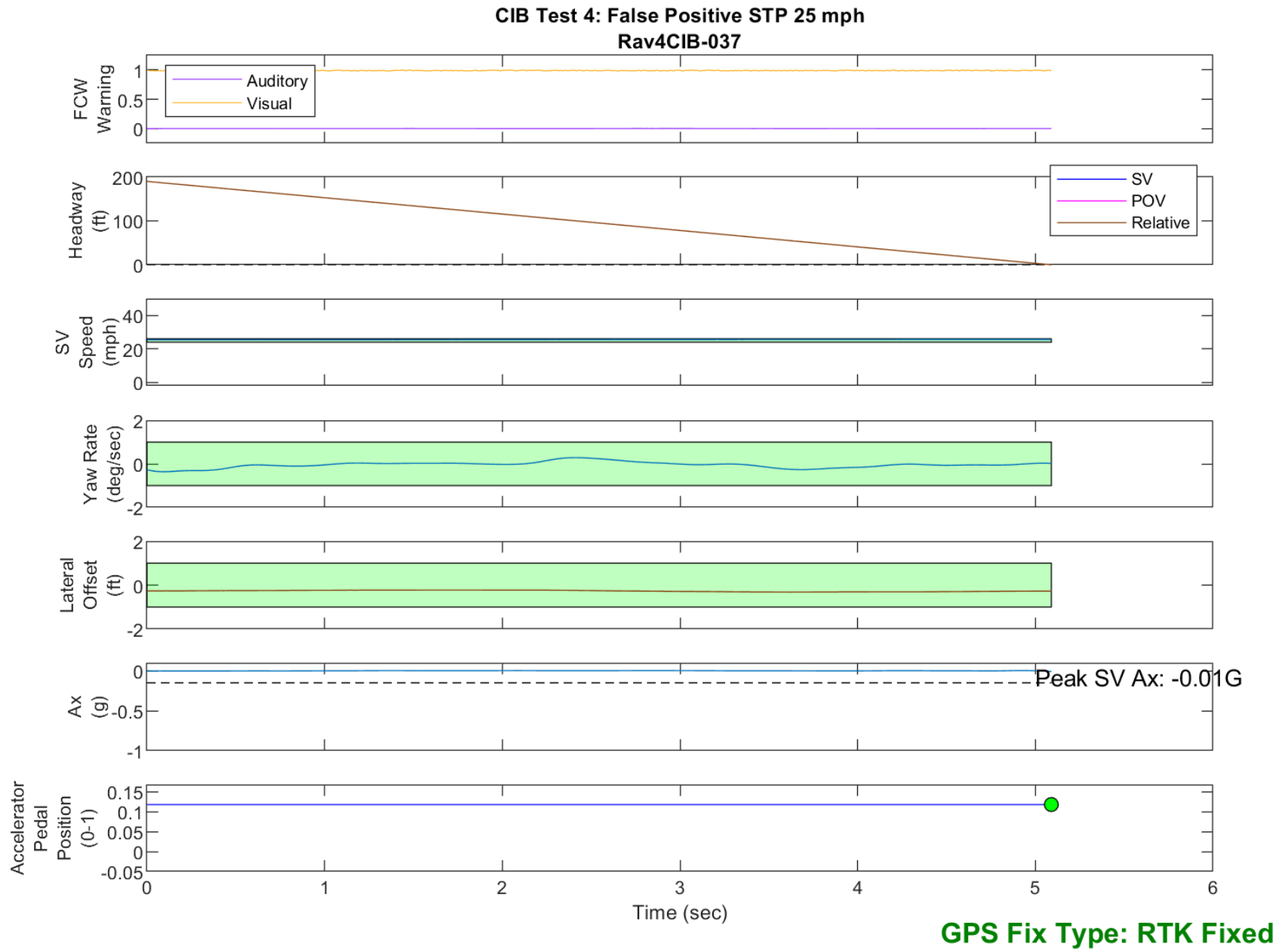

Figure D39. Time History for CIB Run 37, Test 4 - False Positive STP, 25 mph

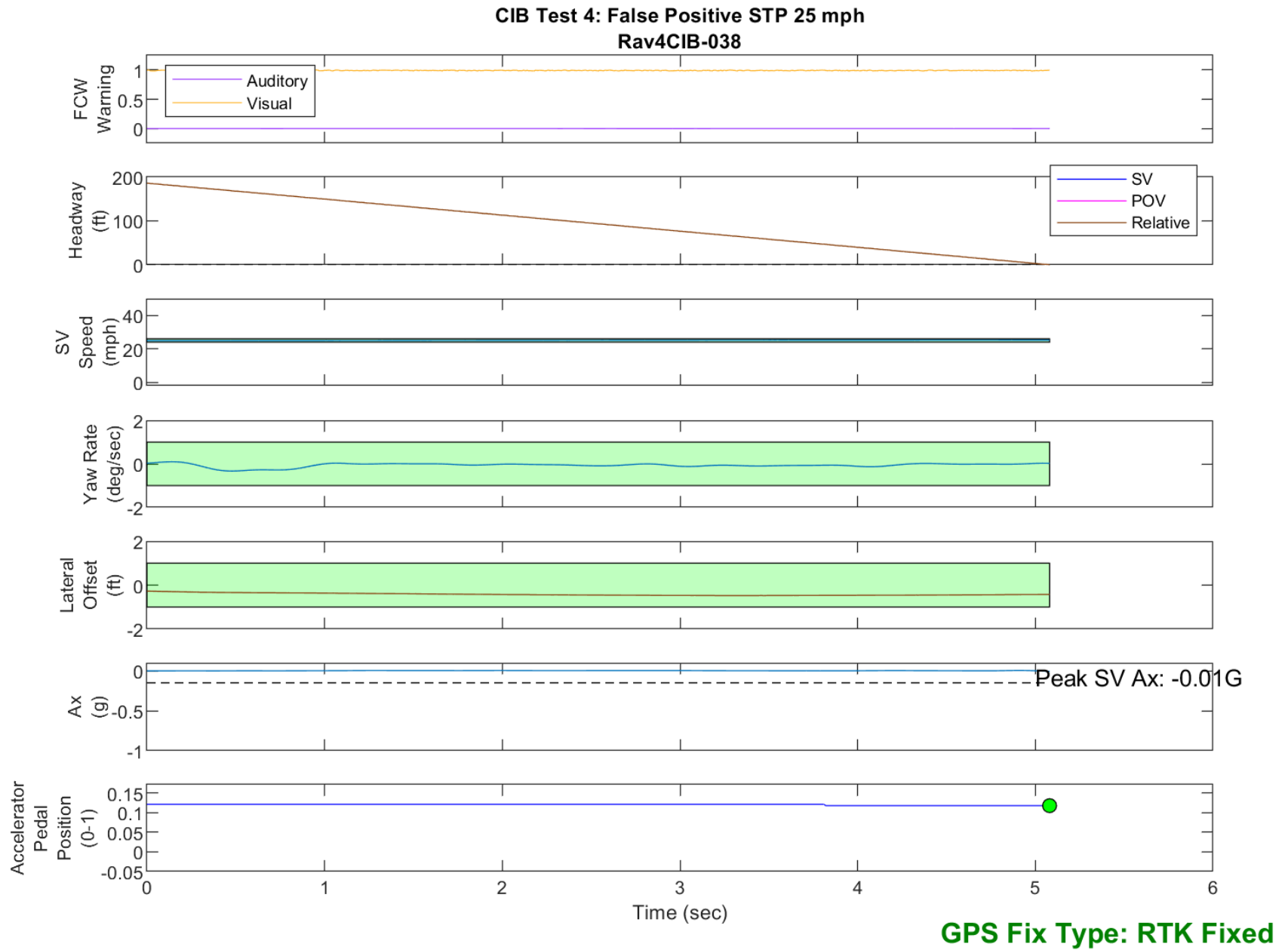

Figure D40. Time History for CIB Run 38, Test 4 - False Positive STP, 25 mph

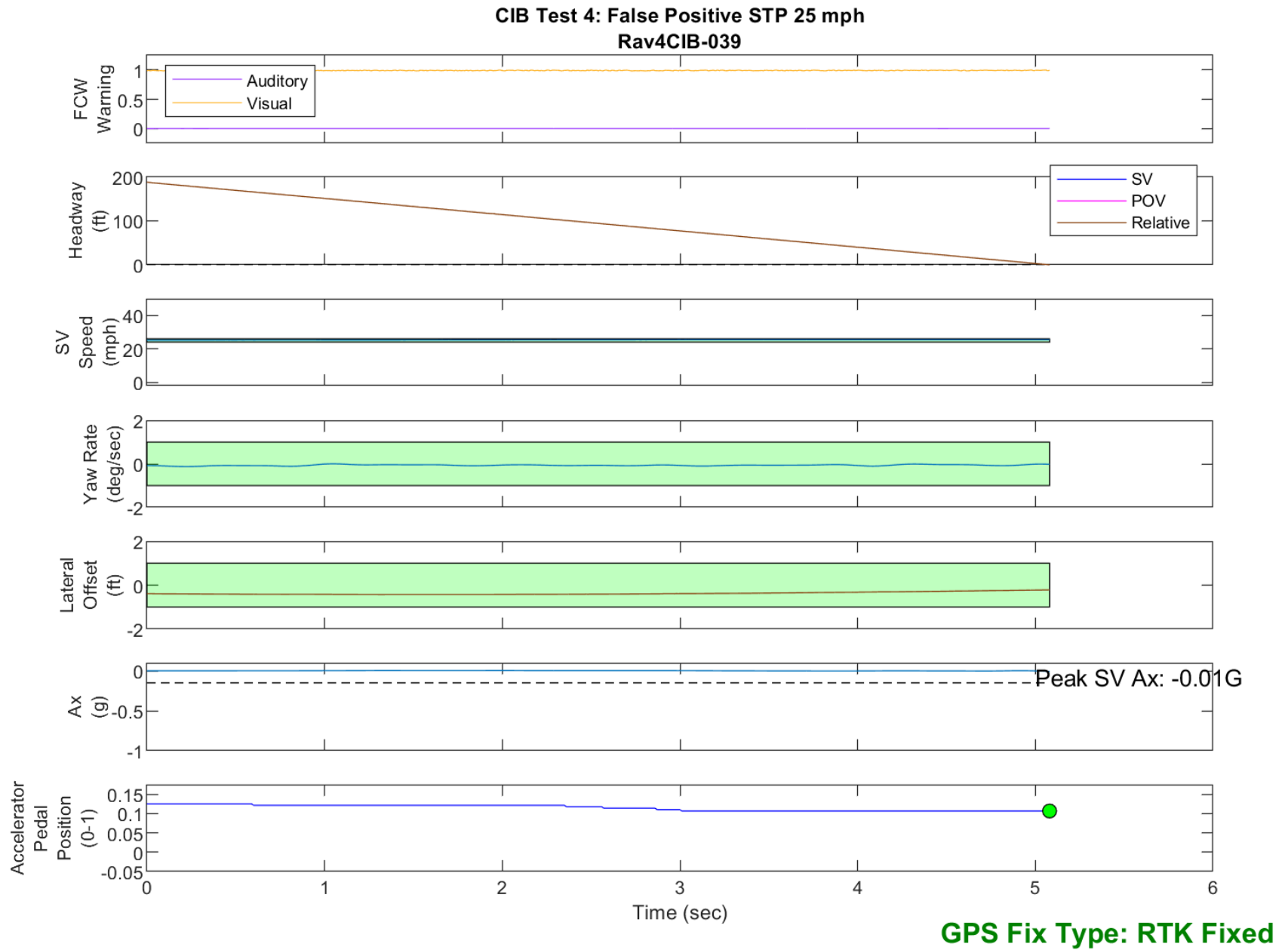

Figure D41. Time History for CIB Run 39, Test 4 - False Positive STP, 25 mph

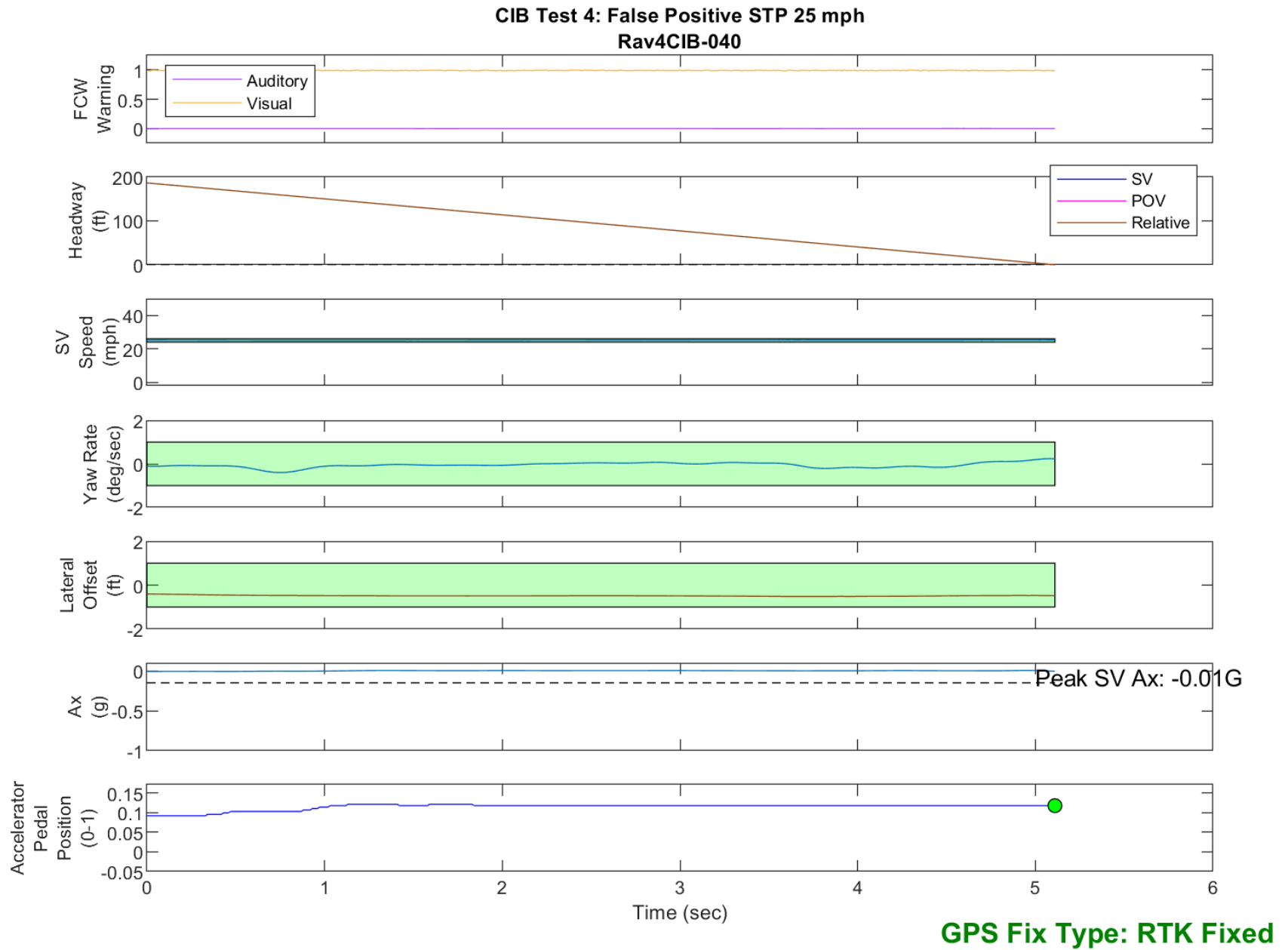

Figure D42. Time History for CIB Run 40, Test 4 - False Positive STP, 25 mph

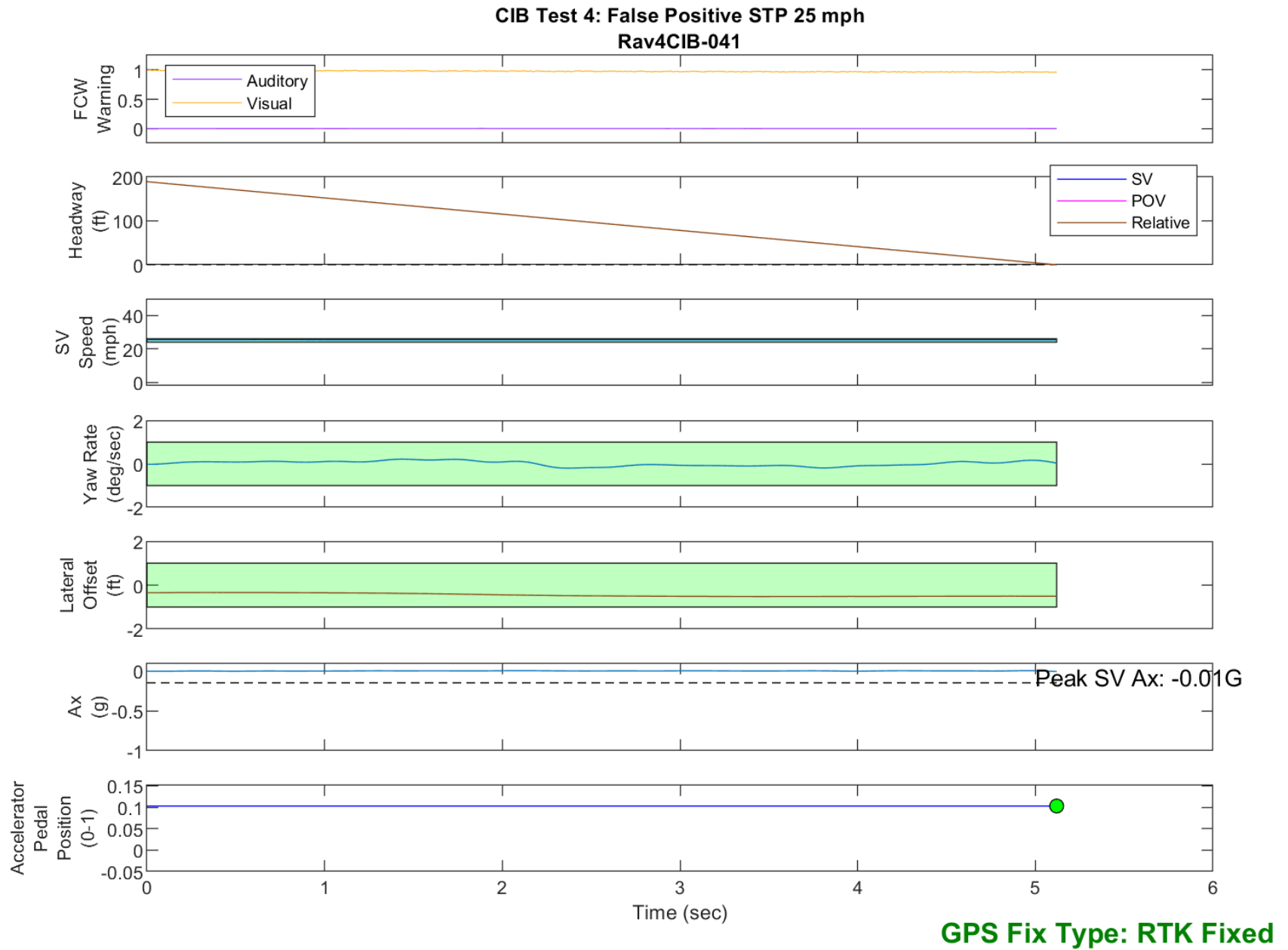

Figure D43. Time History for CIB Run 41, Test 4 - False Positive STP, 25 mph

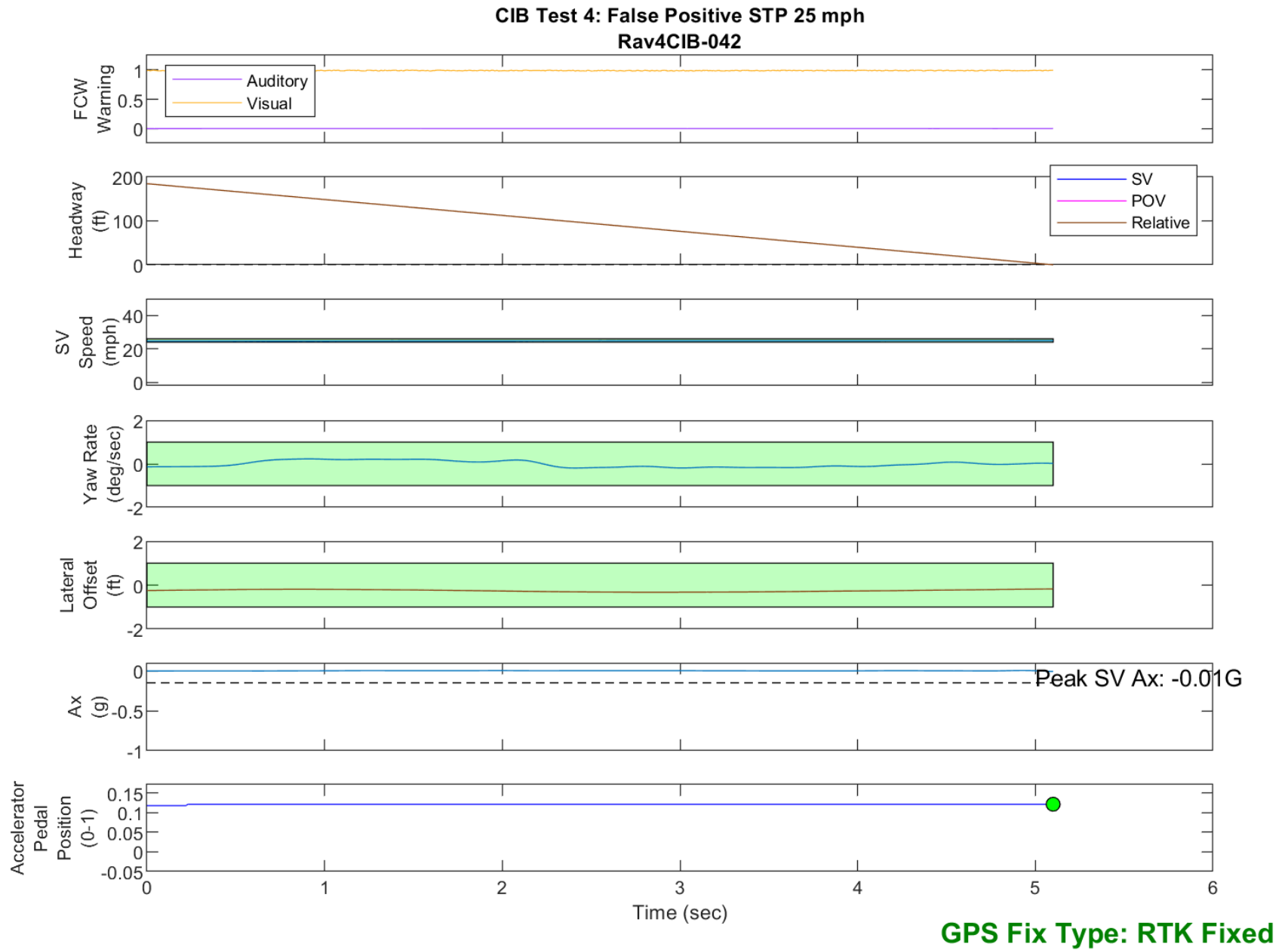

Figure D44. Time History for CIB Run 42, Test 4 - False Positive STP, 25 mph

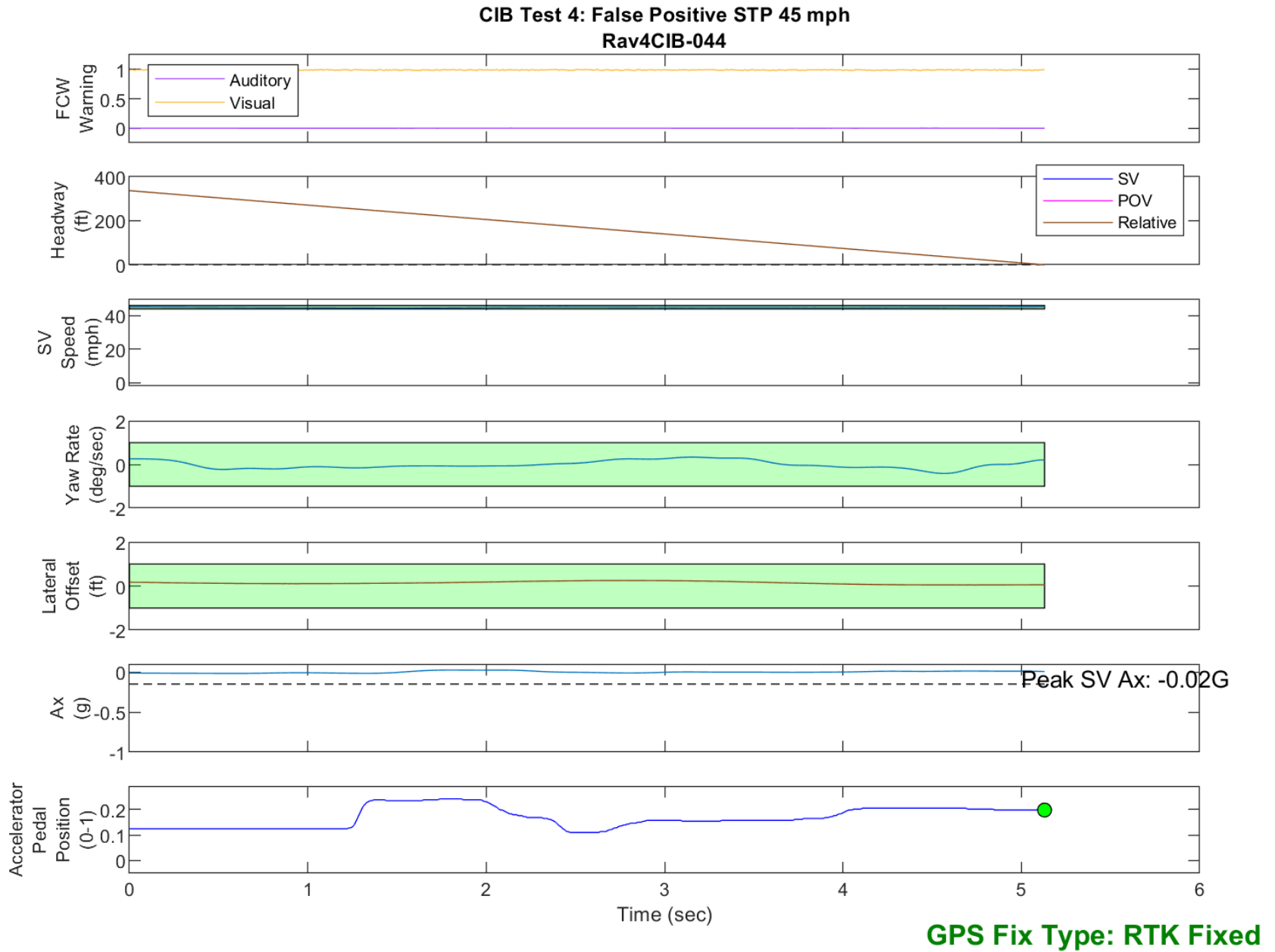

Figure D45. Time History for CIB Run 44, Test 4 - False Positive STP, 45 mph

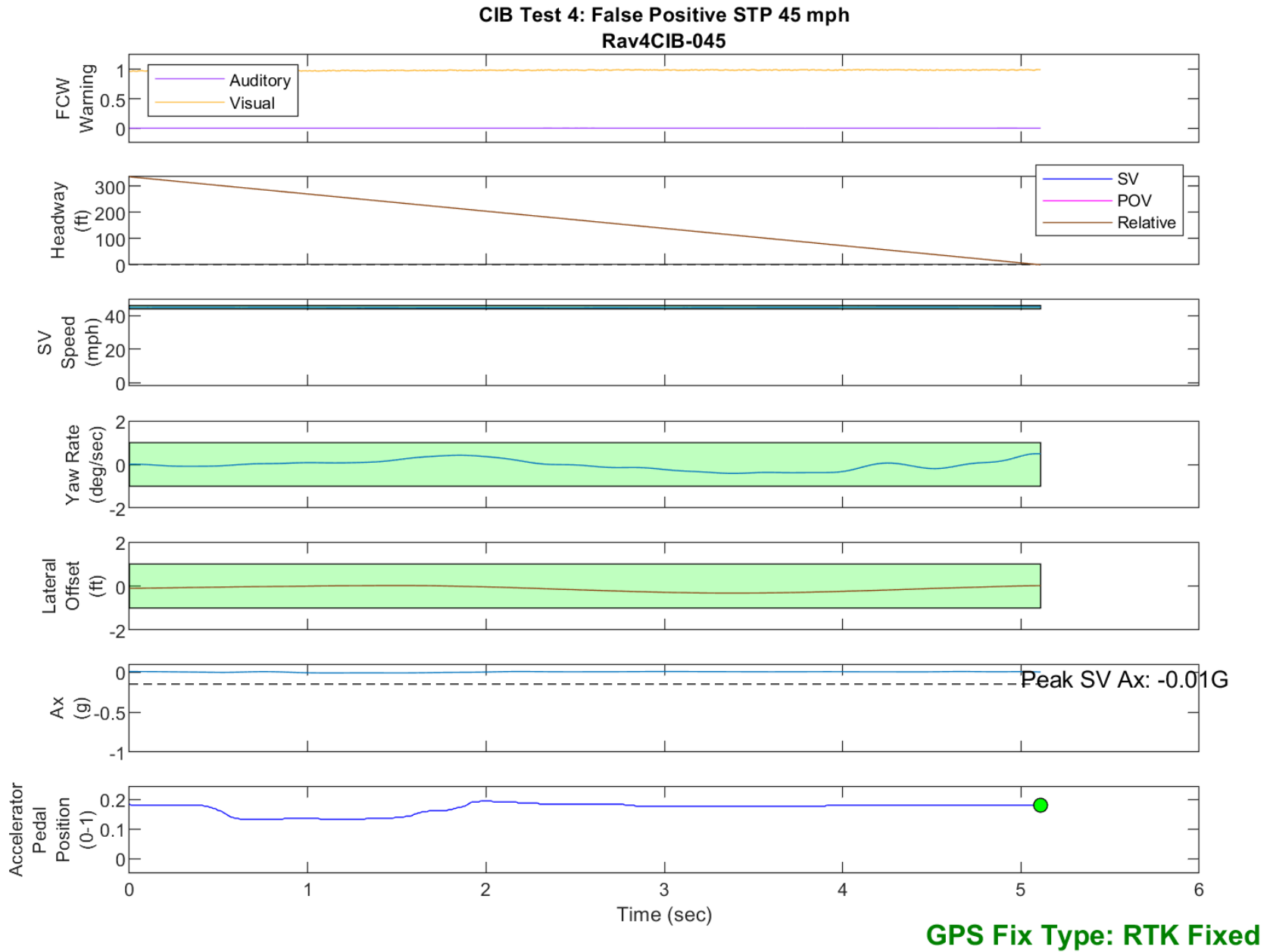

Figure D46. Time History for CIB Run 45, Test 4 - False Positive STP, 45 mph

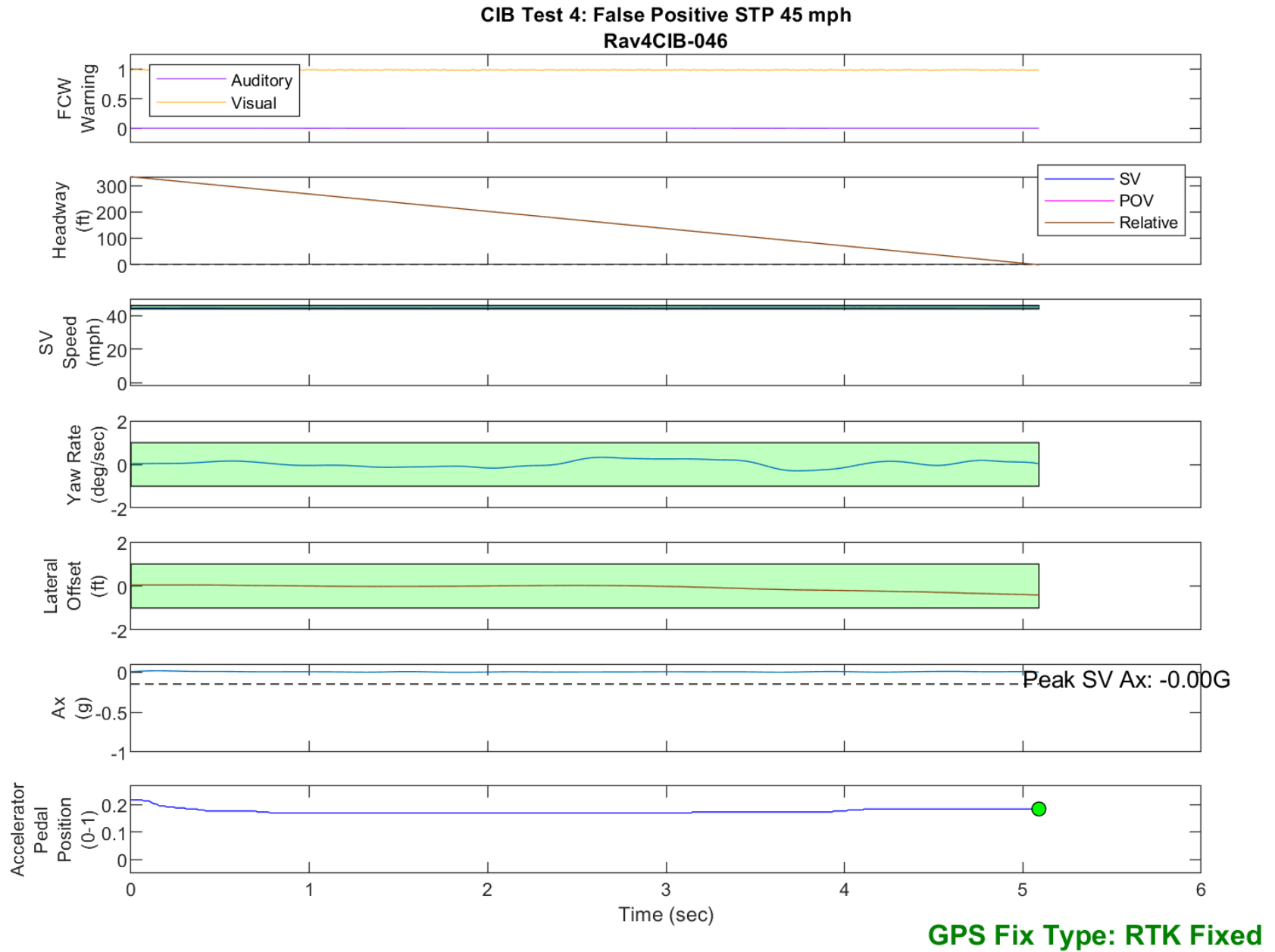

Figure D47. Time History for CIB Run 46, Test 4 - False Positive STP, 45 mph

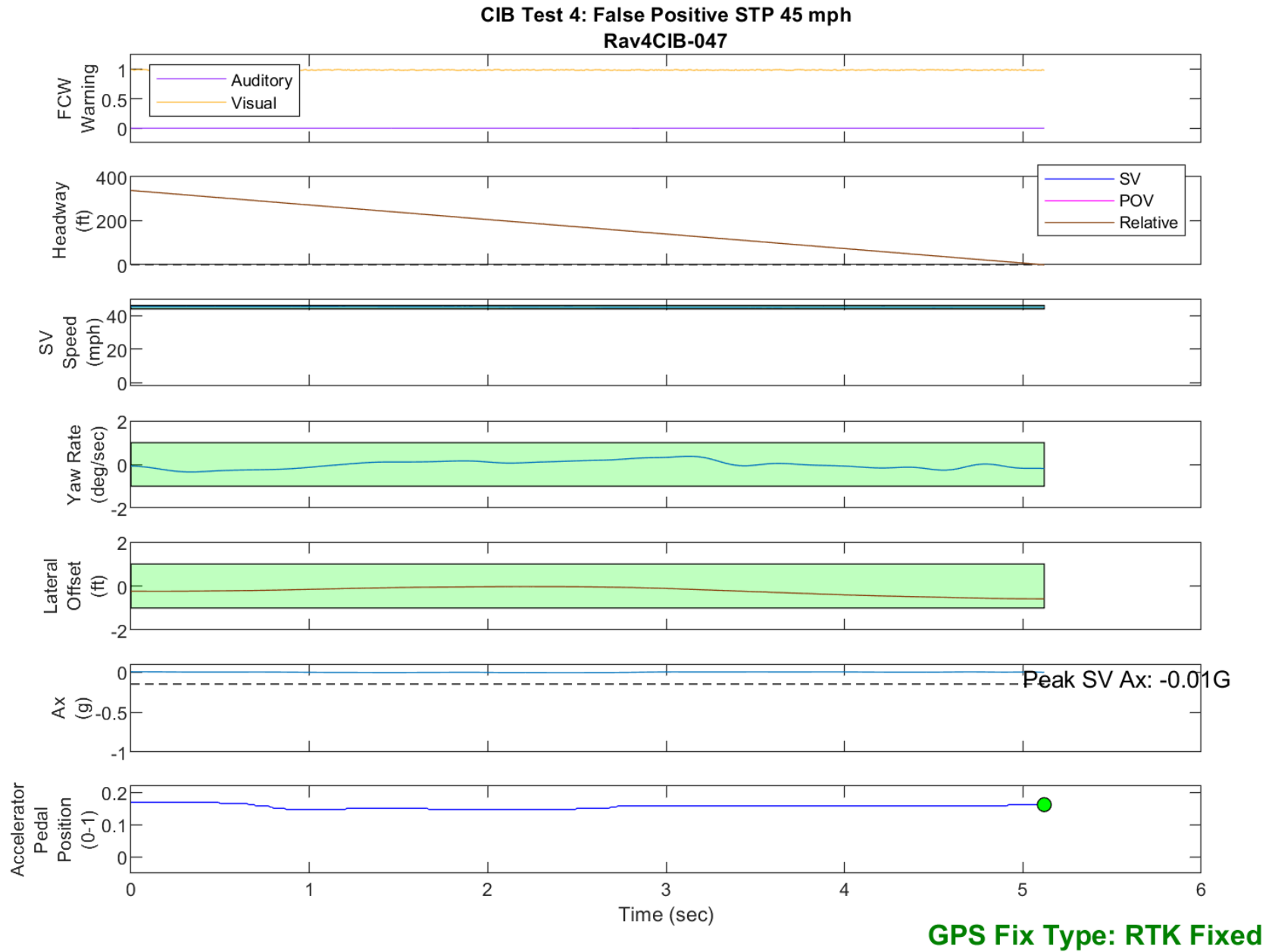

Figure D48. Time History for CIB Run 47, Test 4 - False Positive STP, 45 mph

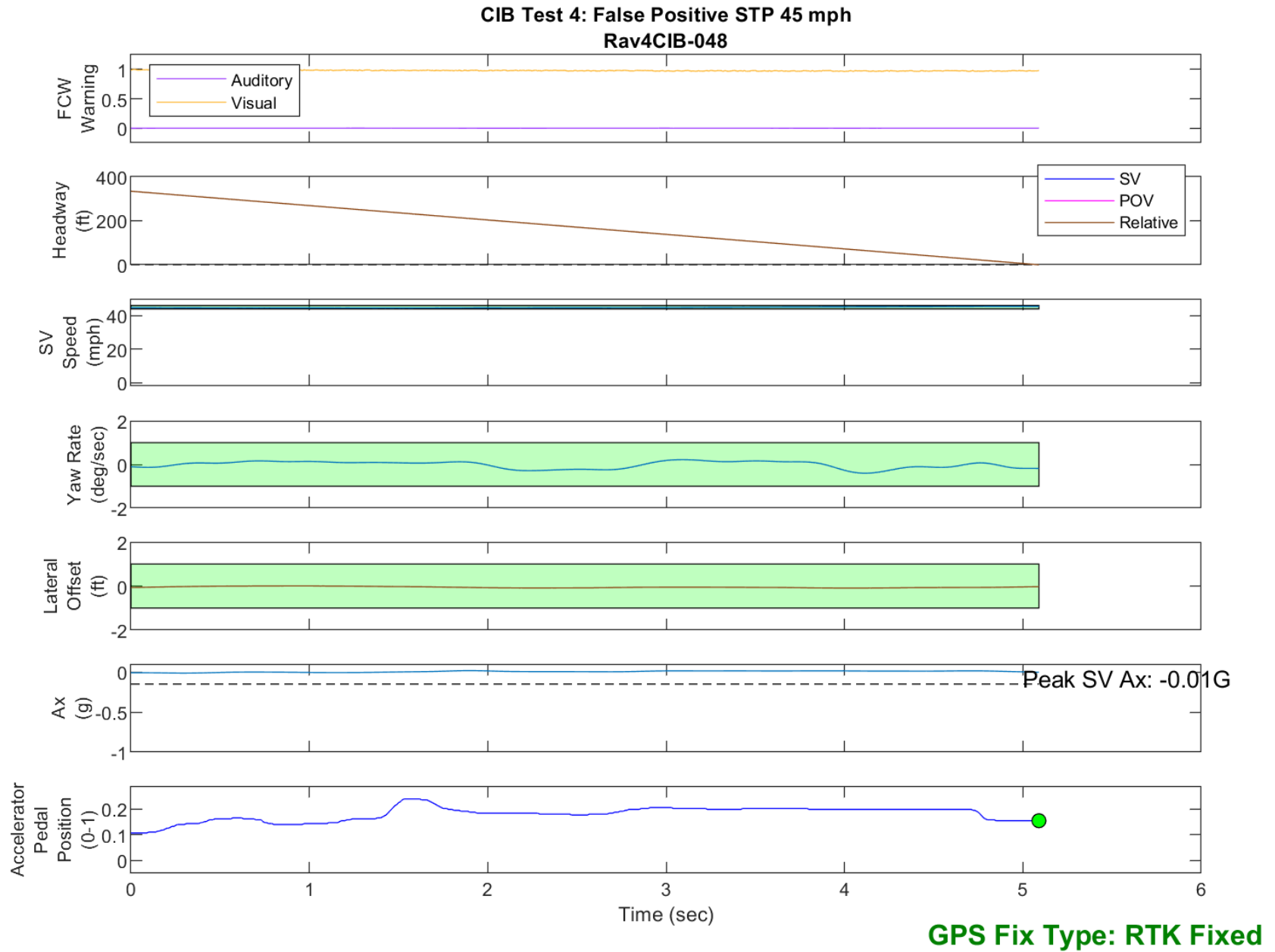

Figure D49. Time History for CIB Run 48, Test 4 - False Positive STP, 45 mph

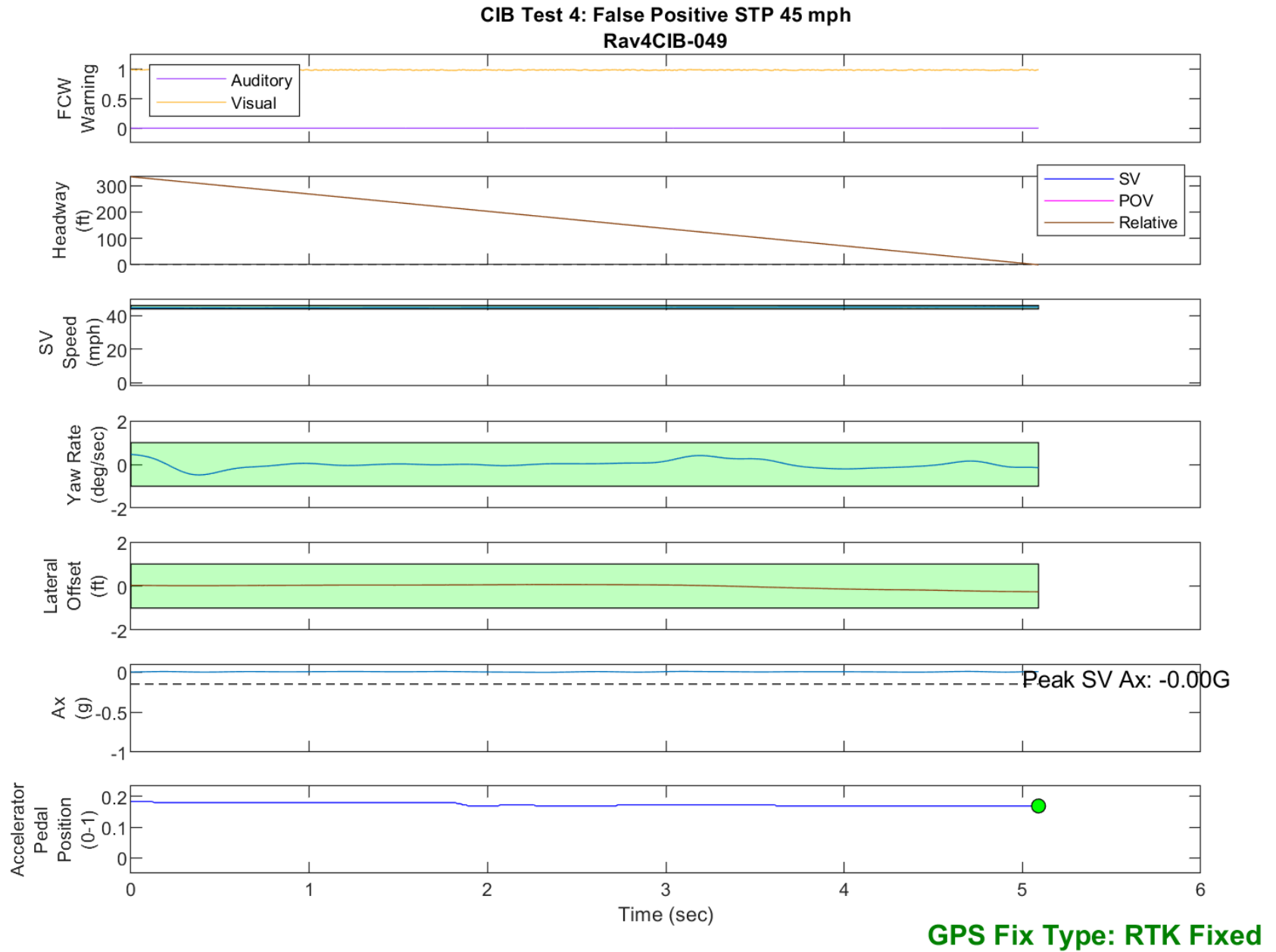

Figure D50. Time History for CIB Run 49, Test 4 - False Positive STP, 45 mph

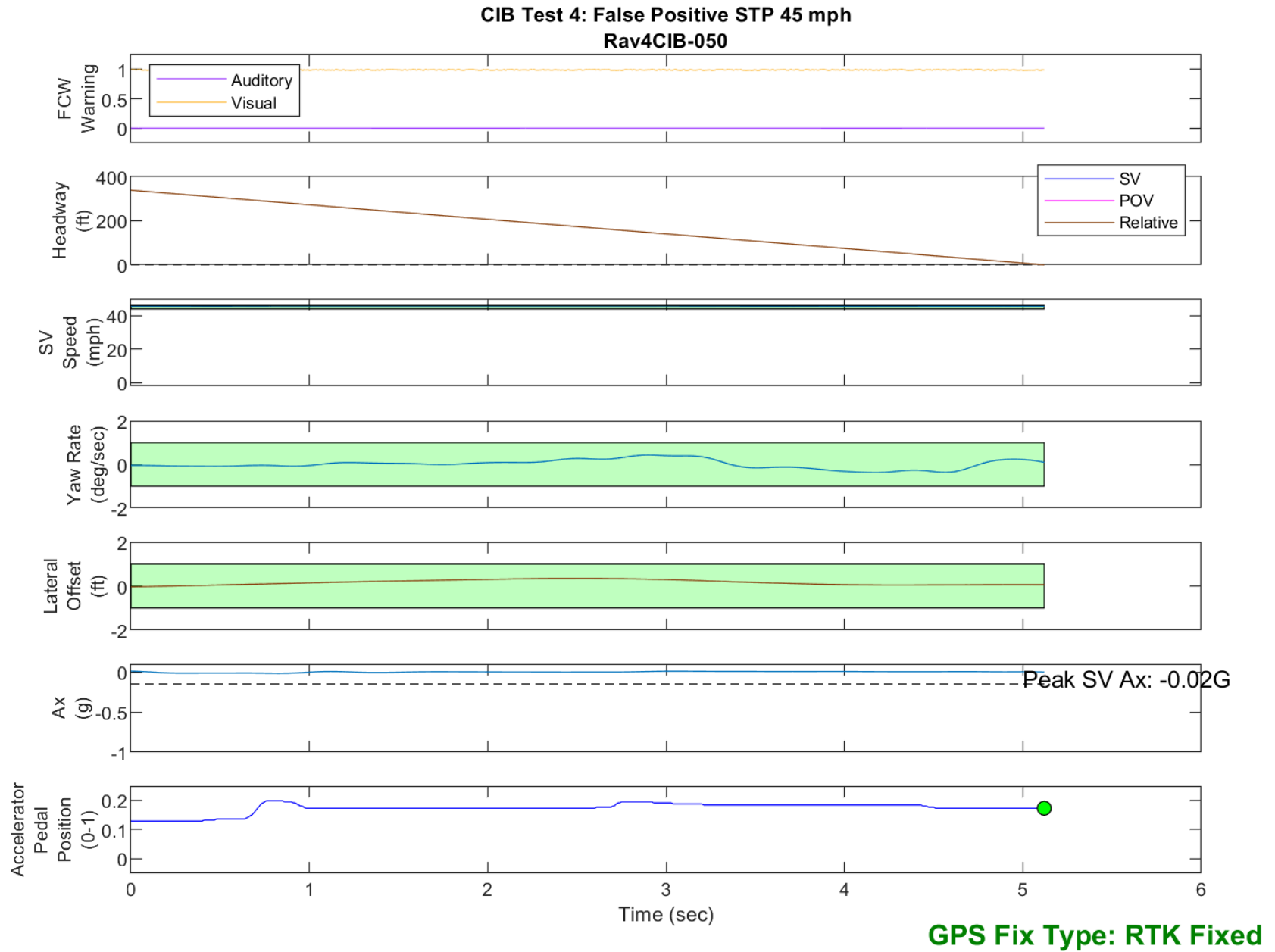

Figure D51. Time History for CIB Run 50, Test 4 - False Positive STP, 45 mph