

DEPARTMENT OF TRANSPORTATION**National Highway Traffic Safety Administration****49 CFR Part 571**

[Docket No. NHTSA–2021–0088]

RIN 2127–AK96

Federal Motor Vehicle Safety Standards; Bus Rollover Structural Integrity

AGENCY: National Highway Traffic Safety Administration (NHTSA), Department of Transportation (DOT).

ACTION: Final rule.

SUMMARY: NHTSA is issuing this final rule to establish Federal Motor Vehicle Safety Standard (FMVSS) No. 227, “Bus rollover structural integrity,” to enhance the rollover structural integrity of over-the-road buses (motorcoaches), and other buses with a gross vehicle weight rating (GVWR) greater than 11,793 kilograms (kg) (26,000 pounds (lb)). This final rule, issued pursuant to the Moving Ahead for Progress in the 21st Century Act (MAP–21), requires the buses to provide a “survival space” in a rollover test to protect occupants from possible collapse of the bus structure around them. In addition, to reduce the likelihood of ejection, this final rule prohibits emergency exits from opening in the rollover test. This final rule ensures that bus roofs and side wall panels will resist deformation and intrusion into the occupant space in rollover crashes, and reduces the risk of emergency exits becoming ejection portals in a crash.

DATES: The effective date of this final rule is: December 30, 2024. Optional early compliance is permitted.

Petitions for reconsideration: Petitions for reconsideration of this final rule must be received not later than February 14, 2022.

ADDRESSES: Petitions for reconsideration of this final rule must refer to the docket number set forth above and be submitted to the Administrator, National Highway Traffic Safety Administration, 1200 New Jersey Avenue SE, Washington, DC 20590. Note that all petitions received will be posted without change to <https://www.regulations.gov>, including any personal information provided.

Privacy Act: Please see the Privacy Act heading under Rulemaking Analyses and Notices.

FOR FURTHER INFORMATION CONTACT: For non-legal issues, you may contact James Myers, NHTSA Office of Crashworthiness Standards, telephone

202–493–0031, fax 202–493–2990. For legal issues: Deirdre Fujita, NHTSA Office of Chief Counsel, telephone 202–366–2992, fax 202–366–3820. Address: National Highway Traffic Safety Administration, U.S. Department of Transportation, 1200 New Jersey Avenue SE, West Building, Washington, DC 20590.

SUPPLEMENTARY INFORMATION:**Table of Contents**

- I. Executive Summary
 - a. Introduction
 - b. How This Final Rule Differs From the Notice of Proposed Rulemaking
 - c. NTSB Recommendations
 - d. Costs and Benefits
 - e. NHTSA’s Determination of MAP–21 Requirements and Considerations
 - f. Retrofitting
- II. Introduction
- III. NHTSA’s Statutory Authority
 - a. National Traffic and Motor Vehicle Safety Act (Safety Act)
 - b. MAP–21 (The Motorcoach Enhanced Safety Act of 2012)
- IV. Safety Need (FARS 2004–2018 Data Analysis)
- V. Summary of the NPRM
- VI. High Level Summary of the Comments
- VII. Scope and Purpose of the Rule
- VIII. Applicability of the Rule
 - a. Medium-Size Buses (Buses With a GVWR of 4,536 to 11,793 kg (10,000–26,000 lb))
 - b. Large Buses
- IX. School Bus Derivative Buses
- X. Performance Requirements
 - a. Severity of the Rollover Test
 - b. Intrusion Into the Survival Space
 - c. Luggage Racks and Seat Anchorages
 - d. Emergency Exits
- XI. Glazing Issues
 - a. Side Glazing on the Non-Struck Side of the Bus
 - b. Type of Glazing
 - c. Moon Roofs
 - d. Struck-Side Window Evaluations
- XII. Test Procedure Issues
 - a. Ballasting the Vehicle
 - b. Vehicle Fluids
 - c. Additional Tools for Survival Space Evaluation During Testing
- XIII. Other Issues
 - a. ECE R.66 Alternative Compliance Methods
 - b. Regulatory Alternatives
 - 1. FMVSS No. 216
 - 2. FMVSS No. 220
 - c. Additional MAP–21 Considerations
- XIV. Lead Time
- XV. Retrofitting Used Buses
- XVI. Overview of Costs and Benefits
- XVII. Rulemaking Analyses and Notices

I. Executive Summary**a. Introduction**

This final rule substantially improves motorcoach safety. It establishes an FMVSS to improve the resistance of motorcoach roofs and side wall panels to deformation and intrusion into the

occupant compartment in rollover crashes, and fulfills a mandate in section 32703(b)(1) of MAP–21. This final rule also accords with section 32703(b)(2) of MAP–21 by requiring emergency exits to remain closed in a rollover to prevent partial and complete ejection of passengers.

This final rule achieves longstanding NHTSA and Departmental goals to enhance motorcoach safety. NHTSA identified four priority areas in which to improve the safety of motorcoaches and other large buses: Requiring passenger seat belts, improved rollover structural integrity, improved emergency evacuation, and fire safety.¹ With this final rule, NHTSA has completed research and rulemaking on the first two priority areas and completed research on the other two.

Congress also focused on these and other areas in incorporating the Motorcoach Enhanced Safety Act of 2012 into MAP–21 (Pub. L. 112–141). Among other matters, MAP–21 directed NHTSA (as delegated by the Secretary of Transportation) to require seat belts in “motorcoaches,” a term, Congress stated, that has the same meaning given the term “over-the-road bus” in section 3038(a)(3) of the Transportation Equity Act for the 21st Century (49 U.S.C. 5310 note). An over-the-road bus (OTRB) is a bus characterized by an elevated passenger deck located over a baggage compartment.² NHTSA has used the term “over-the-road bus” in the FMVSSs issued pursuant to the MAP–21 mandates. For example, NHTSA fulfilled MAP–21’s seat belt mandate by amending FMVSS No. 208, “Occupant crash protection,” to require seat belts in each passenger seating position in OTRBs, as well as in other buses that are not OTRBs (non-OTRBs) with a GVWR greater than 11,793 kg (26,000 lb).³ (For the convenience of the reader, NHTSA uses the term “large buses” in this final rule to refer to OTRBs regardless of GVWR and non-OTRBs with a GVWR

¹ See “NHTSA’s Approach to Motorcoach Safety,” Docket No. NHTSA–2007–28793. In NHTSA’s plan, “motorcoach” referred to inter-city transport buses. In 2009, DOT also issued a Motorcoach Safety Action Plan that addressed additional factors, such as driver fatigue and operator maintenance schedules. An update to the Departmental plan was issued in December 2012, <https://www.fmcsa.dot.gov/sites/fmcsa.dot.gov/files/docs/Motorcoach-Safety-Action-Plan-2012.pdf>. This final rule is an action included in the Departmental plan.

² Under section 32701(6) of the Motorcoach Enhanced Safety Act, “motorcoach” does not include a bus used in public transportation provided by, or on behalf of, a public transportation agency, or a school bus.

³ 78 FR 70416, November 25, 2013; denial of petitions for reconsideration, 81 FR 19902, April 6, 2016.

greater than 11,793 kg (26,000 lb), with some exceptions.)

Section 32703(b)(1) of MAP-21 also directed NHTSA to pursue rulemaking for OTRBs to establish improved roof and roof support standards that substantially improve the resistance of bus roofs to deformation and intrusion in rollovers. MAP-21 requires NHTSA to adopt a final rule if NHTSA determines that such standards meet the requirements and considerations in subsections (a) and (b) of section 30111 of the National Traffic and Motor Vehicle Safety Act.⁴ As discussed in this final rule, NHTSA has made such a determination regarding an FMVSS for all large buses.

This final rule complements the November 2013 seat belt rule. With all new large buses manufactured since 2016 required to have lap and shoulder seat belts for passengers, increasing numbers of passengers can be belted. This final rule establishing FMVSS No. 227 will ensure that these belted passengers will be significantly protected against unreasonable risk of injury in frontal crashes and significantly protected against the risk of ejection in rollovers. Hand-in-hand with the seat belt rule, this final rule enhances the safety of these belted passengers by providing a “survival space” in a rollover, a space where the belted occupants are protected from intruding structures such as a collapsing roof or a detached luggage rack. The new standard’s improvements to the roof and sidewall strength of the buses will also protect unbelted occupants against structural failure of the bus compartment. This final rule improves transportation safety for the most vulnerable in our society since more than half of motorcoach trips are made by children and senior citizens.⁵ It furthers transportation equity by providing the same occupant crash protection to these passengers as the protection provided to occupants of other passenger motor vehicles,⁶ by reducing deaths and injuries due to the crushing of the roof into the occupant compartment in rollover crashes.

This final rule applies to all new large buses, with limited exceptions. The standard does not apply to school buses, prison buses, buses with perimeter

seating, or to transit buses that are not OTRBs. School buses already meet an FMVSS for roof strength, which is FMVSS No. 220, “School bus rollover protection” (49 CFR 571.220). In response to comments, NHTSA has also decided not to apply the standard to “school bus derivative buses,” which this final rule defines as buses built on a school bus platform. These vehicles may not have school bus lights and stop arms meeting FMVSS No. 108 and No. 131, respectively, or seating systems meeting FMVSS No. 222, “School bus seating and passenger protection,” but the buses have safety systems that are otherwise identical to school buses regarding their emergency exits, rollover protection (FMVSS No. 220), bus body joint strength, and fuel system integrity. The vehicles could be certified as meeting the FMVSSs for “school buses” if they had school bus lights meeting FMVSS No. 108, stop arms meeting FMVSS No. 131, and seating systems meeting FMVSS No. 222. Because school bus derivative buses already meet the roof crush resistance requirements in FMVSS No. 220, it would be redundant to require the buses to meet Standard No. 227 established by this final rule.

The test for the large buses adopted by this final rule is the complete vehicle rollover test of United Nations Economic Commission for Europe (ECE) Regulation 66, “Uniform Technical Prescriptions Concerning the Approval for Large Passenger Vehicles with Regard to the Strength of their Superstructure,” (ECE R.66).⁷ The test simulates a real-world rollover crash of a large bus. The test bus is placed on a tilting platform that is 800 mm (24 inches) above a smooth and level concrete surface. One side of the tilting platform along the length of the bus is raised at a steady rate of not more than 5 degrees/second until the vehicle becomes unstable, rolls off the platform, and impacts the concrete surface below. Some commenters to the August 6, 2014 notice of proposed rulemaking (NPRM) (79 FR 46090) thought that the test was too lenient, but NHTSA believes that those views are mistaken. As explained

⁷ Dated February 2006, <https://live.unece.org/fileadmin/DAM/trans/main/wp29/wp29regs/r066r1e.pdf>. ECE R.66 defines “superstructure” as “the load-bearing components of the bodywork as defined by the manufacturer, containing those coherent parts and elements which contribute to the strength and energy absorbing capability of the bodywork, and preserve the residual space in the rollover test.” “Bodywork” means “the complete structure of the vehicle in running order, including all the structural elements which form the passenger compartment, driver’s compartment, baggage compartment and spaces for the mechanical units and components.”

in this preamble, this test imparts severe crash forces that the buses must resist. FMVSS No. 227 prohibits any intrusion into the “survival space” by any part of the vehicle outside the survival space, except for minute objects weighing less than 15.0 grams, such as pebbles of glazing, or bolts and screws, which do not pose an unreasonable risk to safety for occupants.

The “survival space” requirement ensures at least a minimum level of structural integrity for the buses by prohibiting intrusions into the occupant space that can cause harm. It establishes “improved roof and roof support standards” that substantially improve the resistance of the roof to deformation and intrusion, in accordance with MAP-21. It ensures that buses are constructed so that structures outside of the survival space, such as luggage racks and large pieces of glazing, do not enter the survival space in the rollover.

The requirement that emergency exits remain shut during and after the rollover test reduces the likelihood of emergency exits becoming ejection portals during rollovers, which is a goal consistent with MAP-21. Section 32703(b)(2) of MAP-21 requires NHTSA to consider requiring advanced glazing⁸ standards for each motorcoach portal and “other portal improvements to prevent partial and complete ejection of motorcoach passengers, including children.” In NHTSA’s motorcoach tests conducted during development of this rulemaking, roof and side emergency exits opened during the rollover event and the panes of advanced glazing popped out of their mounting. The requirement that emergency exits remain closed is a “portal improvement” established pursuant to section 32703(b)(2). Additionally, the requirement that the glazing panels not intrude into the survival space by detaching from the non-struck side of the bus will ensure the glazing panels remain intact in their mounting during bus rollover crashes and not form ejection portals.⁹

⁸ MAP-21 (section 32702(1)) defines “advanced glazing” as “glazing installed in a portal on the side or the roof of a motorcoach that is designed to be highly resistant to partial or complete occupant ejection in all types of motor vehicle crashes.”

⁹ On May 6, 2016 (81 FR 27904), NHTSA issued an NPRM proposing to establish FMVSS No. 217a to improve glazing materials used in motorcoaches and other large buses. The NPRM proposed an impactor test of glazing material to simulate the loading from an average size adult male impacting a window on the opposite side of a large bus in a rollover. Countermeasures used to meet the test would likely involve the use of advanced glazing. This final rule adopting FMVSS No. 227 would complement FMVSS No. 217a by improving the securement of the advanced glazing in the buses.

⁴ MAP-21, section 32703(b) and (b)(1).

⁵ “Motorcoach Census 2013, A Study of the Size and Activity of the Motorcoach Industry in the United States and Canada in 2012,” American Bus Association Foundation, February 27, 2014.

⁶ Passenger vehicles under 4,536 kg (10,000 lb) GVWR are subject to the requirements of FMVSS No. 216, “Roof crush resistance; Applicable unless a vehicle is certified to § 216a,” or to FMVSS No. 216a, “Roof crush resistance, Upgraded standard.”

b. How This Final Rule Differs From the Notice of Proposed Rulemaking (NPRM)

The most noteworthy differences between this final rule and the NPRM¹⁰ are highlighted below.

1. This final rule adopts the NPRM's proposed ECE R.66 full vehicle test to improve the roof and structural integrity of OTRBs (except for a few buses with unique configurations), and non-OTRBs with a GVWR greater than 11,793 kg (26,000 lb)). The agency proposed to exclude non-OTRBs with perimeter seating from the standard. After evaluation of the comments received, this final rule excludes all perimeter seating buses, as there is not a sufficient reason to distinguish between buses just based on the location of a luggage compartment. Further, all prison buses are excluded due to the unique interior configuration of the buses, as are school bus derived buses, as the latter vehicles already meet NHTSA's school bus roof crush resistance standard.

2. This final rule adopts the NPRM's proposed prohibition that no part of the bus that is outside the survival space shall intrude into the survival space, both during movement of the tilting platform or resulting from impact of the bus on the impact surface. However, given the high force applications imparted to the bus structure in the rollover test, this final rule permits debris caused by the impact to fall into the survival space, such as small glazing pebbles or bolts and screws. The objects must not weigh more than 15.0 grams.

3. This final rule does not adopt the NPRM's proposal that each anchorage of an interior overhead luggage rack or other compartment must not completely separate from its mounting structure during movement of the tilting platform or resulting from impact of the bus on the impact surface. This final rule also does not adopt the NPRM's proposal that seat anchorages must not become dislodged during the test. Under the NPRM, those proposed prohibitions would have applied even if the luggage rack does not enter the survival space, or the seat anchorages dislodged within the survival space. NHTSA has decided that the primary purpose of this rulemaking is to establish a roof strength and crush resistance standard that improves the resistance of roofs to deformation and intrusion, *i.e.*, by providing a survival space to occupants in rollovers. The purpose is achieved by prohibiting *any* structure, such as overhead luggage racks, from intruding into the survival space. By prohibiting overhead luggage racks from impeding

into the survival space in the rollover, overhead luggage racks will have to be better anchored to the bus wall than they had in the past so that they do not detach and intrude into the survival space in the test. Thus, the proposed luggage rack provision is not needed to ensure that a survival space is provided since luggage racks are prohibited from intruding on the survival space. Similarly, the proposed seat anchorage provision is not necessary to achieve a survival space for occupants.

4. This final rule does not adopt the proposed provision that each side window glazing opposite the impacted side of the vehicle must remain attached to its mounting structure so as not to allow the passage of a 102 mm (5-inch) diameter sphere. The sphere test was proposed to ensure that, after the rollover test, the glazing remain firmly attached to its mounting. Because the primary purpose of this rulemaking is to provide a necessary survival space to occupants in rollovers, the purpose is achieved by prohibiting panes of glazing from falling into the survival space. The proposed requirement that the glazing not form openings is not germane to the survival space specification and unnecessarily complicates this rulemaking.

These changes and others are discussed in this preamble.

c. NTSB Recommendations

This final rule accords with the following National Transportation Safety Board (NTSB) recommendations that NTSB issued to NHTSA to improve motorcoach safety.

In an NTSB Highway Special Investigation Report (1999), *Bus Crashworthiness Issues*,¹¹ NTSB cited an October 1971 rollover of a 1970 Motor Coach Industries (MCI) bus as justification for the following recommendations:

“H-99-50 (MW): In 2 years, issue performance standards for motorcoach roof strength that provide maximum survival space for all seating positions and that take into account current typical motorcoach window dimensions.”

“H-99-51: Once performance standards have been developed for motorcoach roof strength, require newly manufactured motorcoaches to meet those standards.”

In November 2009, after investigating an August 2008 Sherman, Texas bus

crash,¹² the NTSB issued two safety recommendations. In this rollover crash, the failure of the overhead luggage rack on the vehicle impeded passenger egress and rescue efforts. Thus, NTSB stated that the Sherman accident and NHTSA's motorcoach testing indicate that the lack of standards for overhead luggage racks on motorcoaches leaves passengers at risk of serious injury from interaction with overhead luggage racks in a crash and made the following recommendations:

“H-09-23: Develop performance standards for newly manufactured motorcoaches to require that overhead luggage racks remain anchored during an accident sequence.”

“H-09-24: Develop performance standards for newly manufactured motorcoaches that prevent head and neck injuries from overhead luggage racks.”

This final rule is consistent with the above NTSB recommendations. NHTSA is issuing performance standards for motorcoach roof strength that provide a survival space for all seating positions and is requiring new motorcoaches to meet those requirements. The standard established by this final rule requires that overhead luggage racks remain anchored during a rollover such that they do not enter the requisite survival space and injure passengers in the survival space.

d. Costs and Benefits

NHTSA has examined the benefits and costs of this final rule to ensure that the agency adopts only those amendments that contribute to improved safety and that are consistent with the directives of MAP-21 and the principles for regulatory decision-making set forth in Executive Order 12866, *Regulatory Planning and Review*. Over the 15-year period between 2004 and 2018, on average 22 fatalities occurred annually to occupants of these buses. Though a relatively small percentage of overall traffic fatalities, data show that rollover crashes are particularly deadly for large buses. Among the 122 fatal crashes, 56 were rollover crashes resulting in 189 fatalities. This final rule enhances passenger protection in rollover crashes in a reasonable and achievable way. As discussed in the next section, NHTSA adopts this final rule because a rollover structural integrity standard meets the requirements and considerations in

¹² NTSB/HAR-09/02 PB2009-916202; Motorcoach Run-Off-the-Bridge and Rollover Sherman, Texas August 8, 2008; October 2009; <https://www.nts.gov/investigations/AccidentReports/Reports/HAR0902.pdf>, last accessed 09/08/2021.

¹¹ National Transportation Safety Board. 1999, *Bus Crashworthiness Issues*. Highway Special Investigation Report NTSB/SIR-99/04. Washington, DC.

¹⁰ NPRM, August 6, 2014 (79 FR 46090).

subsections (a) and (b) of section 30111 of the Safety Act. This rule provides safety to passengers in a reasonable, objective, and cost-effective manner while harmonizing the standard internationally.

NHTSA has determined this rulemaking to be cost beneficial.¹³ The agency estimates the annual cost of this final rule to be between \$4.81 million and \$11.84 million (see Table 1 below). The countermeasures may include stronger roof structure, support pillars, side walls, shock resistant latches for emergency exits, and improved window mounting, resulting in material costs for each bus covered under this final rule ranging from \$325 to \$591. We estimate the total weight increase will range from 181 to 356 kilograms (kg) (399 to 784 pounds (lb))

for each of these buses and cost an additional \$1,862 to \$4,790 in fuel per vehicle over the lifetime of the vehicle.

We estimated the benefits of this rule taking into account the benefits attributable to the agency's final rules on seat belts and electronic stability control (ESC), as those rules also applied to this universe of vehicles. We estimate that requiring the subject buses to meet the rollover structural integrity performance criteria will save approximately 2–3 lives annually. In addition, we expect that the rule will reduce the number of seriously injured occupants by 4 annually. Thus, we estimate that approximately 3.12 equivalent lives are saved annually if 15 percent of occupants use seat belts, and approximately 2.45 equivalent lives are saved annually (undiscounted) if 90

percent of occupants use seat belts (see Table 2 below).

The cost per equivalent life saved is estimated to be \$2.48 million to \$4.99 million when belt use is estimated to be 15 percent, and \$3.17 million to \$6.38 million when belt use is estimated to be 90 percent (see Table 3 below). The net cost/benefit impact ranges from a net benefit of \$13.09 million to \$23.31 million if seat belt usage is 15 percent. If the seat belt usage rate is 90 percent, the estimated net cost/benefit impact ranges from a net benefit of \$8.25 million to a net benefit of \$16.97 million (see Table 4 below). While the cost and benefits of this rule will vary depending on the material/fuel costs per vehicle and on the belt use rate, per all available information this final rule will be cost beneficial.

TABLE 1—ESTIMATED ANNUAL COSTS
[2020 Dollars]

Potential Costs:	
Material Costs per Vehicle	\$325 to \$591.
Material Costs, Total New Fleet	\$0.71 million to \$1.30 million.
Fuel Costs per Vehicle @ 3%	\$2,441 to \$4,790.
Fuel Costs per Vehicle @ 7%	\$1,862 to \$3,654.
Fuel Costs, Total New Fleet	\$4.10 million to \$10.54 million.
Total Annual Cost	\$4.81 million to \$11.84 million.

TABLE 2—ESTIMATED ANNUAL BENEFITS
[Undiscounted equivalent lives saved]

15 percent belt usage	3.12
90 percent belt usage	2.45

TABLE 3—COST PER EQUIVALENT LIFE SAVED
[Across 3% and 7% discount, in millions of 2020 dollars]

15 percent belt usage	2.48–4.99
90 percent belt usage	3.17–6.38

TABLE 4—ANNUALIZED COSTS AND BENEFITS
[In millions of 2020 dollars]

15% belt usage:			
3% Discount Rate	6.08–11.84	29.40	17.56–23.31
7% Discount Rate	4.81–9.34	22.43	13.09–17.61
90% belt usage:			
3% Discount Rate	6.08–11.84	23.05	11.21–16.97
7% Discount Rate	4.81–9.34	17.59	8.25–12.78

e. NHTSA's Determination of MAP-21 Requirements and Considerations

Section 32703(b) and (b)(1) of MAP-21 direct NHTSA: (a) To establish improved roof and roof support standards for motorcoaches that

substantially improve the resistance of motorcoach roofs to deformation and intrusion to prevent serious occupant injury in rollover crashes involving motorcoaches; if (b) NHTSA determines that such standards meet the

requirements and considerations set forth in subsections (a) and (b) of section 30111 of the Safety Act. In addition, section 32703(b)(2) directs NHTSA to consider portal improvements to prevent partial and

¹³NHTSA has developed a Final Regulatory Evaluation (FRE) that discusses issues relating to the potential costs, benefits and other impacts of

this regulatory action. The FRE is available in the docket for this final rule and may be obtained by downloading it or by contacting Docket

Management at the address or telephone number provided at the beginning of this document.

complete ejection of motorcoach passengers, including children, if such standards meet the requirements and considerations set forth in subsections (a) and (b) of section 30111 of the Safety Act.

NHTSA has determined that the standard issued by this final rule meets the requirements and considerations of section 30111(a) and (b) of the Safety Act.

Section 30111(a)

The provision at 49 U.S.C. 30111(a) of the Safety Act authorizes the Secretary (NHTSA, by delegation) to prescribe Federal motor vehicle safety standards that are practicable, meet the need for motor vehicle safety, and are stated in objective terms. “Motor vehicle safety” is defined in the Safety Act as “the performance of a motor vehicle or motor vehicle equipment in a way that protects the public against unreasonable risk of accidents occurring because of the design, construction, or performance of a motor vehicle, and against unreasonable risk of death or injury in an accident, and includes nonoperational safety of a motor vehicle.”¹⁴

NHTSA has determined that the standard issued by this final rule meets the requirements and considerations of section 30111(a) of the Safety Act. The standard is practicable, since it is based on the 2006 ECE R. 66 complete vehicle rollover test. New buses sold in Europe and other countries have been designed to meet the ECE R.66 rollover test requirements for over a decade. Further, NHTSA has conducted the vehicle rollover test of ECE R.66 in developing the NPRM. The three bus rollover tests the agency conducted using the ECE R.66 complete vehicle rollover test procedure showed that the test is feasible and practical for evaluating how well a bus structure maintains occupant survival space in a rollover. The standard is also cost beneficial, and thus is economically practicable.

Standard No. 227 meets the need for safety. Two of the real-world rollover crashes examined for this rule involved buses that had complete roof separation during the rollovers.¹⁵ Almost all the passengers in those two crashes were ejected due to the loss of the bus roofs. This standard will increase the likelihood that bus structures maintain their roof structure and provide a residual survival space for the vehicle occupants. Studies of bus structures before and after implementation of ECE

R.66 have concluded those requirements are effective in protecting bus occupants in rollover crashes.¹⁶ A bus design in use prior to ECE R.66 experienced complete structural collapse of the roof in a rollover crash with one and a half full 360 degree rolls down a 6-meter embankment. That bus model redesigned to meet ECE R.66 requirements was able to maintain adequate survival space in a rollover crash with two and a quarter full 360 degree rolls down a 9–10 meter embankment.¹⁷

This final rule meets the need for safety on many fronts. NHTSA’s Motorcoach Safety Action Plan targeted safety improvements for buses to reduce the incidence of fatalities and serious injuries caused by bus rollover accidents. The seat belt requirements in FMVSS No. 208¹⁸ for large buses provided a means for belted bus occupants to remain within the survival space in a crash. Buses designed to FMVSS No. 227 will provide a survival space for bus occupants. Anti-ejection requirements adopted for bus window portals¹⁹ will reduce the incidence of partial ejection of belted occupants as well as reduce the occurrence of partial or full ejection of unbelted occupants. Further, NHTSA has proposed to establish an FMVSS to require advanced glazing that is highly resistant to occupant ejection for each motorcoach portal, pursuant to section 32703(b)(2) of MAP–21.²⁰ This final rule adopting FMVSS No. 227 would complement FMVSS No. 217a by improving the securement of the advanced glazing in the buses.

The available information shows this final rule is cost beneficial. NHTSA estimates that requiring the subject buses to meet the performance criteria in this final rule will save approximately 2–3 lives and prevent 4 serious injuries annually. NHTSA estimates the net benefits range from \$8.3 million to \$23.3 million.

Standard No. 227 is stated in objective terms. The residual survival space is well defined, based upon a specified boundary at each transverse cross-section of the vehicle, with the cross-sections bounded by specified

¹⁶ Matolcsy, M. (2007), “The Severity of Bus Rollover Accidents,” Enhanced Safety of Vehicles (ESV) Paper 07–152, 20th ESV Conference, Lyon, France. Available at: <https://www.esv.nhtsa.dot.gov/Proceedings/20/07-0152-O.pdf>, last accessed April 26, 2021.

¹⁷ Matolcsy, M. (2006), “Rollover accident with ejection of occupants.” Informal working document of GRSG, No. GRSG–91–7. GRSG, 91st session, Geneva, October 2006.

¹⁸ 78 FR 70416, November 25, 2013.

¹⁹ 81 FR 27904, May 6, 2016.

²⁰ May 6, 2016 (81 FR 27904), supra.

forwardmost and rearmost vehicle landmarks. Potential intrusion into the residual survival space may be objectively measured using standard test measurement methodologies—such as templates representing the outline of the residual survival space and high-speed video. The FMVSS No. 227 test procedure matches the full vehicle test procedure of ECE R.66. Studies have shown the ECE R.66 full vehicle rollover test to be a relatively severe loading condition replicating real-world bus rollover crashes.²¹

Section 30111(b)

The provision at 49 U.S.C. 30111(b) specifies that, when prescribing such standards, the Secretary must consider all relevant, available motor vehicle safety information, consult with the states as appropriate, consider whether a standard is reasonable, practicable, and appropriate for the types of motor vehicles or motor vehicle equipment for which it is prescribed, and consider the extent to which the standard will carry out the statutory purpose of section 30101 of the Act. Section 30101 states that the purpose of the statute is to reduce traffic accidents and deaths and injuries resulting from traffic accidents, and that it is therefore necessary to prescribe FMVSS, and to carry out needed safety research and development.

NHTSA has issued this final rule in accordance with section 30111(b). As discussed throughout this document, the agency concludes, after comprehensive reviews of relevant available safety information that includes over 15 years of crash data and development of a NHTSA plan for motorcoach safety,²² that adopting FMVSS No. 227 meets the requirements and considerations of the Safety Act. NHTSA has provided the public with opportunities to review and provide input on the agency’s safety plan and comment on adoption of this structural integrity final rule when it was in proposed form. This final rule accords with National Transportation Safety Board Recommendations H–99–50, H–99–51, H–09–23, and H–09–24, and NHTSA expects wide public support overall for this final rule. NHTSA has determined that FMVSS No. 227 is reasonable and appropriate for the

²¹ Matolcsy, M. (2007), “The Severity of Bus Rollover Accidents,” Enhanced Safety of Vehicles (ESV) Paper 07–152, 20th ESV Conference, Lyon, France. Available at: <https://www.esv.nhtsa.dot.gov/Proceedings/20/07-0152-O.pdf>, last accessed April, 26 2021.

²² NHTSA’s Approach to Motorcoach Safety (2007), (Docket No. NHTSA–2007–28793–001), supra.

¹⁴ 49 U.S.C. 30102(a)(8).

¹⁵ These rollover crashes occurred in Turrell, Arkansas in 2004 and Mexican Hat, Utah in 2008.

vehicles to which the standard applies for improving bus occupant protection in rollover crashes and that establishing FMVSS No. 227 meets the purpose and policy of the Safety Act.

f. Retrofitting

NHTSA has decided not to require existing large buses to meet the requirements adopted today for new buses. None of the commenters supported a retrofitting requirement. Based on its tests of older buses, the agency believes that many existing buses may need major structural changes to the vehicle's sidewall and roof structure to meet the requirements adopted in this document. Such structural changes are likely to be cost-prohibitive, making retrofitting impracticable.

II. Introduction

Over the 15-year period between 2004 and 2018, data from NHTSA's Fatality Analysis Reporting System (FARS) indicate there were 122 fatal crashes involving large buses. These crashes resulted in 326 occupant fatalities (274 passenger and 52 driver fatalities). During this period, on average 22 fatalities occurred annually to occupants of these buses.

Data indicate that rollover crashes are a particular safety problem for these buses. Among the 122 fatal crashes, 56 were rollover crashes resulting in 189 fatalities. While fatal rollover crashes constitute about 43 percent of all fatal crashes involving these bus types, they represent about 58 percent of all the occupant fatalities. Further, 56 percent of the rollover crash fatalities were attributable to occupant ejections (106 ejection fatalities out of the total of 189 fatalities in bus rollover crashes).

Congress was especially concerned about motorcoach rollover crashes in passing provisions of MAP-21 relevant to this final rule. MAP-21 requires DOT to "establish improved roof and roof support standards for motorcoaches that substantially improve the resistance of motorcoach roofs to deformation and intrusion to prevent serious occupant injury in rollover crashes involving motorcoaches" if such standards meet the requirements and considerations set forth in subsections (a) and (b) of section 30111 of title 49, United States Code.²³ Under MAP-21, "motorcoach" means an OTRB, but does not include a bus used in public transportation provided by, or on behalf of, a public transportation agency, or a school bus. MAP-21²⁴ also directs DOT to consider

"portal improvements to prevent partial and complete ejection of motorcoach passengers, including children."

In accordance with MAP-21 and the Safety Act, we have issued this rollover-specific rule to apply to buses associated with an unreasonable risk of fatal rollover involvement. Thus, this final rule applies to OTRBs, and to all non-OTRBs with a GVWR greater than 11,793 kg (26,000 lb) (large buses), with some exceptions. The final rule excludes school buses, prison buses, non-OTRB transit buses, and buses with perimeter seating.²⁵ We have applied this rule to meet the requirements and considerations of MAP-21 and the Safety Act.

NHTSA is enhancing the safety of large buses in rollovers both by providing a survival space in the occupant compartment, and by reducing the likelihood of emergency exits opening during bus rollovers and becoming ejection portals. NHTSA achieved an important first step enhancing the safety of the buses in rollovers by the November 25, 2013 final rule that requires lap/shoulder belts for all passengers in large capacity buses.²⁶ This final rule builds on the rollover protection provided by seat belts by ensuring the buses provide a protective survival space for belted and unbelted retained occupants in rollovers. The 2013 seat belt rule significantly increased the ability of occupants of large buses to be retained in the bus structure in rollover crashes. This final rule provides the retained occupants a survival space in the bus structure, and strengthens the bus structure and emergency exit portals to protect unbelted occupants as well.

III. NHTSA's Statutory Authority

NHTSA is issuing this final rule pursuant to and in accordance with its authority under the National Traffic and Motor Vehicle Safety Act and the relevant provisions of MAP-21.

a. National Traffic and Motor Vehicle Safety Act (Safety Act)

Under 49 United States Code (U.S.C.) Chapter 301, Motor Vehicle Safety (49 U.S.C. 30101 *et seq.*), the Secretary of Transportation is responsible for prescribing motor vehicle safety standards that are practicable, meet the need for motor vehicle safety, and are stated in objective terms (section

²⁵ Under the standard, a bus with perimeter seating is a bus with 7 or fewer designated seating positions rearward of the driver's seating position that are forward-facing or can convert to forward-facing without the use of tools.

²⁶ NHTSA estimates that seat belts are 77 percent effective in preventing fatalities in rollover crashes.

30111(a)). "Motor vehicle safety" is defined in the Safety Act (section 30102(a)(8)) as "the performance of a motor vehicle or motor vehicle equipment in a way that protects the public against unreasonable risk of accidents occurring because of the design, construction, or performance of a motor vehicle, and against unreasonable risk of death or injury in an accident, and includes nonoperational safety of a motor vehicle." "Motor vehicle safety standard" means a minimum standard for motor vehicle or motor vehicle equipment performance (section 30102(a)(9)). When prescribing such standards, the Secretary must consider all relevant available motor vehicle safety information (section 30111(b)(1)). The Secretary must also consider whether a proposed standard is reasonable, practicable, and appropriate for the particular type of motor vehicle or motor vehicle equipment for which it is prescribed (section 30111(b)(3)) and the extent to which the standard will further the statutory purpose of reducing traffic accidents and associated deaths and injuries (section 30111(b)(4)). The responsibility for promulgation of FMVSSs is delegated to NHTSA (49 CFR 1.95).

b. MAP-21 (Incorporating the Motorcoach Enhanced Safety Act of 2012)

NHTSA is issuing this final rule in accordance with MAP-21, which incorporates the "Motorcoach Enhanced Safety Act of 2012" into Subtitle G.²⁷ Section 32703(b) of MAP-21 requires the Secretary (NHTSA by delegation) to prescribe regulations that would address certain aspects of motorcoach crash performance within two years if the agency determines that the standards would meet the requirements and considerations of section 30111(a) and (b) of the National Traffic and Motor Vehicle Safety Act.²⁸

There are two subsections of section 32703(b) that are particularly relevant to this final rule. Subsection (b)(1) specifies that the Secretary is to establish improved roof and roof support standards that "substantially improve the resistance of motorcoach roofs to deformation and intrusion to prevent serious occupant injury in rollover crashes involving motorcoaches." Subsection (b)(2) directs the Secretary to "consider advanced glazing standards for each motorcoach portal and [to] consider other portal

²⁷ Moving Ahead for Progress in the 21st Century Act, Public Law 112-141 (Jul. 6, 2012).

²⁸ *Id.* at section 32703(b).

²³ MAP-21, section 32703(b)-(b)(1).

²⁴ *Id.*, section 32703(b)(2).

improvements to prevent partial and complete ejection of motorcoach passengers, including children.”²⁹

MAP–21 contains other provisions pertaining to this rulemaking. Section 32702 states that “motorcoach” has the meaning given to the term “over-the-road bus” in section 3038(a)(3) of the Transportation Equity Act for the 21st Century (TEA–21).³⁰ Section 3038(a)(3) of TEA–21 (see 49 U.S.C. 5310 note) defines “over-the-road bus” as “a bus characterized by an elevated passenger deck located over a baggage compartment.” However, section 32702 of MAP–21 excludes transit buses and school buses from the “motorcoach” definition.³¹

MAP–21 further directs the Secretary to apply any regulation prescribed in accordance with section 32703(b) to all motorcoaches manufactured more than 3 years after the date on which the regulation is published.³² In addition, the Secretary may assess the feasibility, benefits, and costs of applying any requirement established under section 32703(b)(2) to “motorcoaches manufactured before the date on which the requirement applies to new motorcoaches” (retrofit).³³ Finally, MAP–21 also authorizes the Secretary to combine the required rulemaking actions as the Secretary deems appropriate.³⁴

IV. Safety Need (FARS 2004–2018 Data Analysis)

This rulemaking is conducted pursuant to the requirements of the Safety Act and MAP–21. It investigates whether there are unreasonable safety risks associated with rollover crashes in OTRB transportation, and if there are such risks, whether those safety risks can be reasonably reduced by having at least minimum levels of performance

specified for rollover structural integrity and portal improvements.

This rulemaking improves occupant safety in large bus rollover crashes. While developing the November 25, 2013 seat belt final rule, NHTSA found that most fatalities in OTRB crashes are attributable to rollovers. Because more than half of the rollover fatalities are attributable to ejections, NHTSA issued a seat belt requirement to mitigate those ejections.

Enhancing the structural integrity of the interior of these buses works together with the seat belt rule. More occupants will be able to be retained in the bus compartment because of the belts, so it makes sense to require a survival space that protects these restrained occupants in a rollover. Moreover, regardless of whether occupants are belted, data³⁵ show that the risk of serious injuries and fatalities can be reduced by improving the vehicle structure to protect occupants against collapsing roofs and bus components falling or intruding into the survival space. Additionally, emergency exits should remain closed in a crash, as an open exit forms a portal through which occupants could be completely or partially ejected. This final rule adopts requirements to meet these objectives.³⁶

Updated Data Analysis (FARS Data 2004–2018)

After the August 6, 2014 NPRM, NHTSA re-analyzed FARS data files for the years 2004 to 2018 to assess the impacts of this rulemaking.³⁷ The bus body types coded in FARS are “school bus,” “transit bus,” “cross country/intercity bus” to represent OTRBs (motorcoaches), “other bus” to represent other types of buses, and “unknown bus” to represent buses that could not be categorized into the other four bus

body type categories. Since 2011, a new bus body type, “van-based buses” was included. We also examined the FARS body type “Large Van” for van-based bus crashes for the years 2004–2018 where the vehicle was used to transport people. The buses can also be categorized by their GVWR: GVWR less than or equal to 10,000 lb, GVWR greater than 10,000 lb and less than or equal to 26,000 lb, and GVWR greater than 26,000 lb. The manner in which a bus was used is coded in FARS as “school bus,” “intercity bus,” “transit/city bus,” “shuttle bus,” and “modified for personal/private use.”

To assess the benefits and costs of this rule, the agency selected buses of body type “over-the-road bus (OTRB)” regardless of GVWR³⁸ and “other bus,” “unknown bus” and “van-based bus” body types with a GVWR greater than 26,000 lb, regardless of the manner in which they were used.³⁹ NHTSA also included fatal crashes of large vans with a GVWR greater than 26,000 lb used for transporting people (used as intercity bus, charter/tour bus, commuter bus, and shuttle bus) and found none for the 15-year period from 2004 to 2018.

For the 15-year period from 2004 to 2018, there were a total of 326 bus occupant fatalities in the bus types covered by of FMVSS No. 227 (see Table 5). Among these fatalities, 230 were occupants of OTRBs with a GVWR greater than 26,000 lb, 15 were occupants of OTRBs with GVWR <26,000 lb, and 81 were occupants in buses coded as “other bus,” “unknown bus,” and “van-based bus” with a GVWR greater than 26,000 lb. In this 15-year period, fatalities among occupants of OTRBs account for 75 percent of the 326 fatalities.

TABLE 5—BUS CRASH OCCUPANT FATALITIES IN THE BUS TYPES COVERED BY FMVSS NO. 227 [FARS data 2004–2018]

Year	OTRB GVWR <26,000 lb	OTRB GVWR >26,000 lb	Other bus GVWR >26,000 lb	Unknown bus GVWR >26,000 lb	Van-based GVWR >26,000 lb	Total
2004	0	23	4	0	27
2005	0	10	3	4	17

²⁹ While this final rule is mainly aimed at addressing the rollover structural integrity of specific large bus types, the reduced deformation of the bus structure would ensure that any advanced glazing installed on portals would be retained on their mounting and reduce the risk of occupant ejection in rollover crashes. Further, the requirement that emergency exits should not open during the rollover test would also ensure that the exits do not become ejection portals. Thus, both subsection (b)(1) and subsection (b)(2) are relevant to this rule.

³⁰ Moving Ahead for Progress in the 21st Century Act, Public Law 112–141, section 32702(6).

³¹ *Id.* at section 32702(6)(A)–(B).

³² *Id.* at section 32703(e)(1).

³³ *Id.* at section 32703(e)(2). “Retrofit Assessment for Existing Motorcoaches.”

³⁴ *Id.* at section 32706.

³⁵ Maétołcsy, M (2012), “Passenger’s Ejection in Bus Rollover Accident,” FISITA 2012 World Automotive Congress, paper F2012 F02–005. Available at <https://unece.org/DAM/trans/doc/2012/wp29grsg/GRSG-103-02e.pdf>. Last accessed May 03, 2021.

³⁶ This final rule does not address the issue of glazing breaking in a rollover crash that would

result in openings through which occupants could be completely or partially ejected even if emergency exits remain closed. This matter is addressed in the 2016 NPRM for advanced glazing (81 FR 27904), *supra*.

³⁷ Later in this preamble we discuss our analysis of updated data regarding buses with a GVWR of 10,000–26,000 lb.

³⁸ All OTRBs (cross country/intercity buses) are covered under MAP–21.

³⁹ Crashes and fatalities of unknown GVWR buses were proportionally distributed amongst the known values.

TABLE 5—BUS CRASH OCCUPANT FATALITIES IN THE BUS TYPES COVERED BY FMVSS NO. 227—Continued
[FARS data 2004–2018]

Year	OTRB GVWR <26,000 lb	OTRB GVWR >26,000 lb	Other bus GVWR >26,000 lb	Unknown bus GVWR >26,000 lb	Van-based GVWR >26,000 lb	Total
2006	0	8	2	3		13
2007	1	18	8	0		27
2008	0	38	2	0		40
2009	0	9	1	0		10
2010	0	11	1	0		12
2011	0	30	0	0		30
2012	2	12	1	0	1	16
2013	9	8	3	1	0	21
2014	1	18	5	1	0	25
2015	0	12	3	6	0	21
2016	1	8	26	0	0	35
2017	1	5	1	0	0	7
2018	0	13	5	0	0	18
Total	15	230	65	15	1	326

The bus occupant fatalities were further classified by the type of crash (rollover, front, side, rear). FARS also coded fatal bus events “other” that could not be classified into one of the four crash types. The bus occupant fatalities in these “other” bus crash types were further analyzed and found to result from occupants jumping or

falling off the bus, bus fire, explosion inside the bus, heavy object falling on an occupant, and fatal injuries to an occupant that are not crash related. Because these fatalities were not crash related, we did not include them in the count of bus crash fatalities.

In the 15-year period from 2004 to 2018, there were 122 fatal bus crashes

of bus types covered by FMVSS No. 227, among which 71 involved OTRBs with a GVWR greater than 26,000 lb (Table 6). Among the 122 crashes, 56 were rollover events, 59 were frontal crashes, 7 were side crashes, and 0 were rear crashes.

TABLE 6—FATAL CRASHES OF BUS TYPES COVERED BY FMVSS NO. 227
[FARS 2004–2018]

Bus body type and GVWR	Rollover	Frontal	Side	Rear	Total
OTRB (GVWR ≤26,000 lb)	7	2	0	0	9
OTRB (GVWR >26,000 lb)	35	33	3	0	71
Other (GVWR >26,000 lb)	11	18	3	0	32
Unknown (GVWR >26,000 lb)	3	5	1	0	9
Van-based (GVWR >26,000 lb)	0	1	0	0	1
Total	56	59	7	0	122

The 122 fatal bus crashes (involving bus types covered under FMVSS No. 227) resulted in 326 bus occupant fatalities (52 drivers and 274 passengers), as shown in Table 7. Among these fatalities, 189 persons (11 drivers, 178 passengers) died in 56

rollover crashes. In contrast, 116 persons (40 drivers, 76 passengers) died in 59 frontal crashes. Bus rollover crashes accounted for 58 percent of the total bus occupant fatalities and 65 percent of the passenger fatalities.

These data show the devastating nature of bus rollover events, where a

significant number of fatal or serious injuries can occur in a single bus rollover event. Among the 189 fatalities in bus rollover events, 149 fatalities (79 percent) were in OTRBs with a GVWR greater than 26,000 lb.

TABLE 7—BUS OCCUPANT FATALITIES IN CRASHES OF BUS TYPES COVERED BY FMVSS NO. 227 BY BUS BODY TYPE, GVWR, CRASH TYPE, AND OCCUPANT TYPE
[FARS data 2004–2018]

Bus body type and GVWR	Rollover		Front		Side		Rear		All types		Total Driv ± Pass
	Driv	Pass	Driv	Pass	Driv	Pass	Driv	Pass	Driv	Pass	
OTRB (GVWR ≤26,000 lb)	2	11	1	1	0	0	0	0	3	12	15
OTRB (GVWR >26,000 lb)	7	142	25	46	1	9	0	0	33	197	230
Other (GVWR >26,000 lb)	1	23	12	23	0	6	0	0	13	52	65
Unknown (GVWR >26,000 lb)	1	2	2	5	0	5	0	0	3	12	15
Van-based (GVWR >26,000 lb)	0	0	0	1	0	0	0	0	0	1	1
Total	11	178	40	76	1	20	0	0	52	274	326

NHTSA also examined bus rollover events by the ejection status of occupants, among bus types covered by

FMVSS No. 227 (see Table 8). Among the 178 passenger fatalities in bus

rollover events, 98 were to occupants ejected or partially ejected from the bus.

TABLE 8—BUS OCCUPANT FATALITIES IN ROLLOVERS IN BUS TYPES COVERED BY FMVSS NO. 227 BY BUS BODY TYPE, GVWR, OCCUPANT TYPE, AND EJECTION STATUS [FARS 2004–2013]

Bus body type and GVWR	Driver		Passenger	
	Not ejected	Ejected	Not ejected	Ejected
OTRB (GVWR ≤26,000 lb)	0	2	4	7
OTRB (GVWR >26,000 lb)	3	4	60	82
Other bus (GVWR >26,000 lb)	0	1	16	7
Unknown bus (GVWR >26,000 lb)	0	1	0	2
Van-based bus (GVWR >26,000 lb)	0	0	0	0
Total	3	8	80	98

These data show that while transportation by OTRBs (and other similar large buses) is an overall safe form of transportation, given the high occupancy of these vehicles, a significant number of fatal or serious injuries can occur in a single crash. This is especially true in bus rollover crashes that result in occupant ejections.

V. Summary of the NPRM

The NPRM underlying this final rule published August 6, 2014 (79 FR 46090). The agency proposed adoption of a new FMVSS No. 227 to set performance requirements that large buses must meet when tested using the full vehicle ECE R.66 test.

In support of the NPRM, the agency researched two existing roof crush/rollover standards: FMVSS No. 220, “School bus rollover protection,” and ECE R.66, “Uniform Technical Prescriptions Concerning the Approval of Large Passenger Vehicles with Regard to the Strength of their Superstructure.”⁴⁰ The agency

purchased three different bus models for this test program. Two older models were selected because they were representative of the range of roof characteristics (such as design, material, pillars, shape, etc.) of large bus roofs in the U.S. fleet. The vehicles selected were two 12.2 meters (m) (40 feet) long model year (MY) 1992 MCI model MC-12, and two 12.2 m (40 feet) long MY 1991 Prevost model (Prevost) LeMirage buses. The agency also procured a MY 2000 MCI bus, Model 102–EL3, that was 13.7 m (45 foot) in length. All five of the buses purchased were tested to requirements in either FMVSS No. 220 or ECE R.66. A summary of the testing program can be found in the NPRM, *supra*, in section IV.b (79 FR 46100–46102).⁴¹

Applicability

NHTSA proposed FMVSS No. 227 to apply to: (a) All new OTRBs, regardless

⁴¹ For further information on the four older buses tested, a detailed discussion of the tests and results are available in the docket entry NHTSA–2007–28793–0019. For further information on the newer vehicle tested, see the test report, “ECE Regulation 66 Based Research Test of Motorcoach Roof Strength, 2000 MCI 102–EL3 Series Motorcoach, NHTSA No.: MY0800,” October 1, 2009, Report No.: ECE 66–MGA–2009–001, which can be found on NHTSA’s website. https://www-nrd.nhtsa.dot.gov/database/aspx/searchmedia2.aspx?database=v_6797&mediatype=r&r_:tstno=6797, Report 8. Step-by-step instructions on accessing the research report can be found in a memorandum in Docket No. NHTSA–2007–28793–0025.

of GVWR; and (b) all new buses other than OTRBs with a GVWR greater than 11,793 kg (26,000 lb), including prison buses and double-decker buses.⁴² NHTSA focused on improving the rollover protection of buses with a GVWR greater than 26,000 lb because these were high-occupancy vehicles with an exceptionally high involvement in fatal rollovers. The agency also focused on the buses to which the agency’s November 25, 2013 final rule on passenger seat belts applied.

Performance Requirements

The NPRM proposed performance requirements that the buses must meet when subjected to a dynamic rollover test. The proposed test procedure replicated a rollover crash in a controlled manner. In the proposed test, the bus is placed on a tilting platform that is 800 mm (31.50 inches) above a smooth and level concrete surface. One side of the tilting platform along the length of the vehicle is raised at a steady rate of not more than 5 degrees/second until the vehicle becomes unstable, rolls off the platform, and impacts the concrete surface below with its roof leading edge. The rollover structural integrity test is illustrated below in Figure 1.

BILLING CODE 4910–59–P

⁴² Excepted from the NPRM were all school buses, and non-OTRB transit buses and non-OTRBs with perimeter seating.

⁴⁰ ECE R.66 defines “superstructure” as “the load-bearing components of the bodywork as defined by the manufacturer, containing those coherent parts and elements which contribute to the strength and energy absorbing capability of the bodywork, and preserve the residual space in the rollover test.” “Bodywork” means “the complete structure of the vehicle in running order, including all the structural elements which form the passenger compartment, driver’s compartment, baggage compartment and spaces for the mechanical units and components.” (Footnote added.)

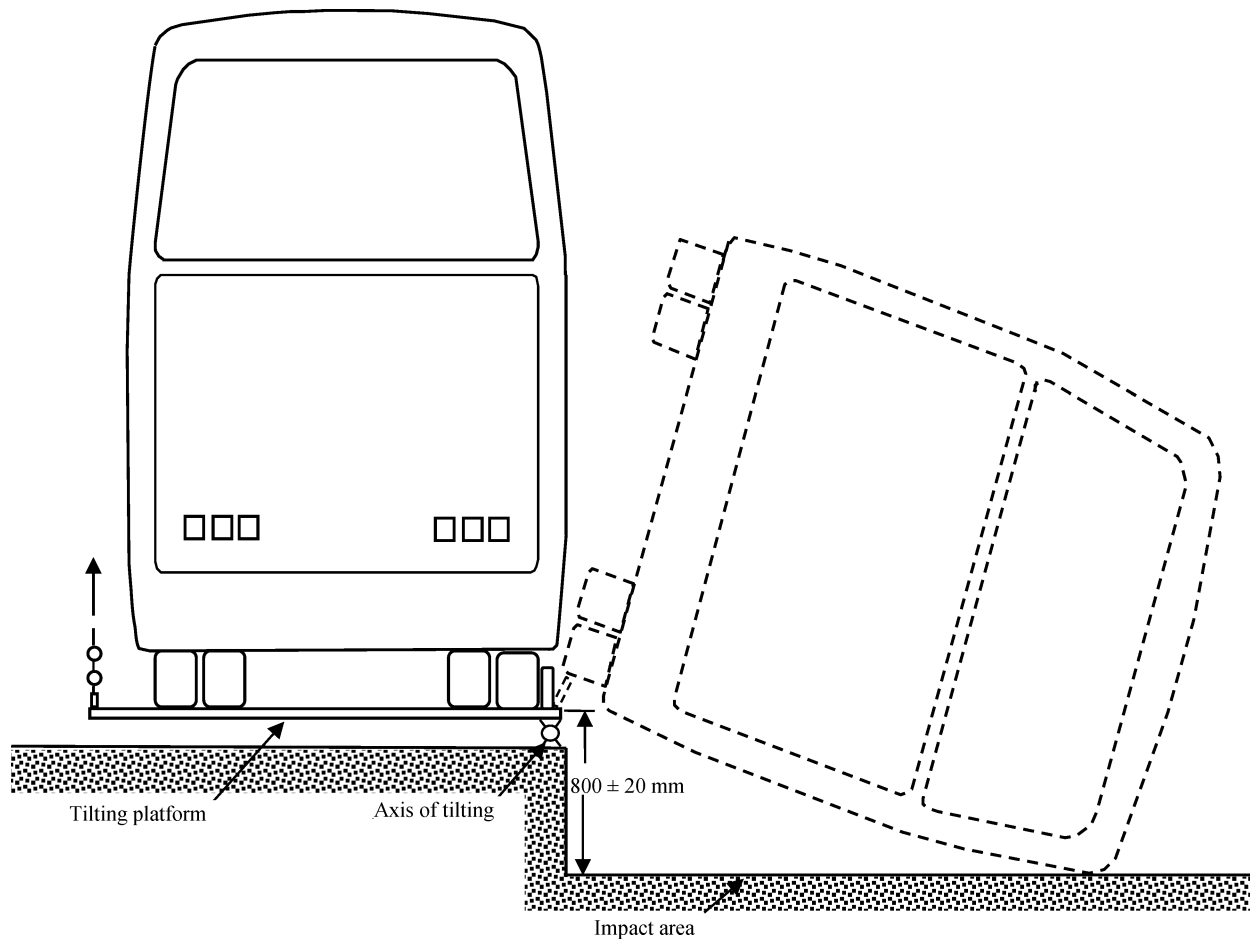

Figure 1: Vehicle on Tilting Platform

BILLING CODE 4910-59-C

NHTSA proposed that the agency could position the bus such that either side (right or left) of the vehicle may be tested for compliance, at the agency's option. The NPRM proposed that a mass of up to 68 kg (150 lb) (ballast) be secured in each designated seating position (DSP) equipped with a seat belt.

The main proposed performance requirements were as follows:

(1) Intrusion into the survival space by any part of the vehicle outside the survival space would be prohibited;

(2) Each anchorage of all seats and interior overhead luggage racks and compartments would be prohibited from completely separating from its mounting structure during movement of the tilting platform or from impact of the bus on the impact surface;⁴³

⁴³One reason for the proposal for overhead luggage racks was to further enhance structural integrity. NHTSA thought that, to meet the luggage rack retention requirement, a bus would have to limit its deformation and "racking" in the test. "Racking" means the tilting of the sides of the bus relative to the bus floor. The retention requirement

(3) Emergency exits would be required to remain shut during the test, and, after the test, be operable in the manner required under FMVSS No. 217, "Bus emergency exits and window retention and release"; and,

(4) Each side window glazing on the non-impacted side and roof of the vehicle would be required to remain attached to its mounting such that there is no opening that allows the passage of a 102 mm (4 inch) diameter sphere when a force of no more than 22 Newtons (N) is applied to the sphere at any vector in a direction from the interior to the exterior of the vehicle.

The proposed requirements described in paragraphs (2), (3) and (4) are beyond those specified in ECE R.66. The ECE regulation mainly assesses the strength of the "superstructure"⁴⁴ in preventing

would have applied to luggage racks regardless of their position relative to the survival space. If the rack separated from its mounting it would be a failure, even if the overhead luggage rack did not enter the survival space.

⁴⁴ECE R.66 Revision 1 defines "superstructure" as "the load-bearing components of the bodywork as defined by the manufacturer, containing those

intrusion into the survival space (ECE R.66 uses the term "residual space" rather than survival space). The regulation specifies that the superstructure of the vehicle shall have sufficient strength such that no part of the vehicle that is outside the residual space at the start of the test (e.g., pillars, luggage racks) shall intrude into the residual space during the test.

VI. High Level Summary of the Comments

NHTSA received 19 comments on the NPRM from commenters that included large bus manufacturers producing large buses domestically and abroad (Van Hool, TEMSA, Prevost, MCI, Daimler EvoBus, Daimler Trucks/Thomas Built Buses, IC Bus), small (final-stage) manufacturers (Hemphill Brothers (Hemphill), NiteTrain Coach (NiteTrain)), a bus industry group (American Bus Association (ABA)), a

coherent parts and elements which contribute to the strength and energy absorbing capability of the bodywork, and preserve the residual space in the rollover test."

glazing industry group (Enhanced Protective Glass Automotive Association (EPGAA)), motorcoach operators (Greyhound, Hemphill, NiteTrain⁴⁵), the National Transportation Safety Board (NTSB), a research laboratory (Florida A&M University's and Florida State University's Crashworthiness and Impact Analysis Laboratory (CIAL)), a consumer advocacy group (Advocates for Highway Safety (Advocates)), a group of families of passengers involved in six bus crashes, and two private citizens.

There was almost unanimous support for an FMVSS on large bus structural integrity, but differing views on what that standard should require. European bus manufacturers Van Hool and TEMSA opposed the proposed requirements and test procedures that differed from ECE R.66, believing that the ECE R.66 test was appropriate for assessing the strength of the bus superstructure and that subsystems such as seats, overhead racks, emergency exits, and glazing should not be assessed under the proposed standard. ABA concurred with this view. Daimler Trucks/Thomas Built Buses and IC Bus generally supported the intent and requirements of the NPRM but supported incorporating the test procedure of FMVSS No. 220, "School bus rollover protection" (49 CFR 571.220), rather than the test of ECE R.66, for school bus derived buses.

Hemphill and NiteTrain expressed concern about the test burdens on small manufacturers and suggested, as did ABA and Prevost, excluding entertainer buses from the standard. MCI and Van Hool suggested excluding prison transport buses and double-decker buses, respectively.

Consumers and consumer groups believed the proposal was not stringent enough or sufficiently representative of a high speed motorcoach rollover crash involving a bus sliding down an embankment. There were concerns expressed about the sphere test not representing the force imposed by an

⁴⁵ Both Hemphill and NiteTrain describe themselves not only as manufacturers of "entertainer buses" but also providers of motorcoach transportation services to the entertainment industry, operating the vehicles under contractual arrangements. Hemphill states that the majority of the contractual arrangements for operating the motorcoaches exceed 30 days, with many contracts covering periods of more than one year. Both Hemphill and NiteTrain describe "entertainer buses" as customized vehicles that include kitchens, bathrooms, bedrooms and lounging areas. Passengers are members of entertainment groups, including the lead artists, band members, road managers, stage hands and others, traveling on the road to different performance venues.

unbelted passenger thrown against the bus window. EPGAA believed that the proposed requirements should have accounted more for the potential use of advanced glazing as an ejection-mitigation countermeasure.

NTSB and CIAL believed the proposed standard should apply to all non-OTRBs with a GVWR greater than 4,536 kg (10,000 lb), rather than just to non-OTRBs with a GVWR greater than 11,793 kg (26,000 lb). NTSB also suggested the proposed performance requirements should apply to "moon roofs" and to side emergency doors.

No commenter supported a retrofit requirement.

VII. Scope and Purpose of the Rule

NHTSA proposed in the NPRM that the scope of FMVSS No. 227 would be to establish performance requirements for bus rollover structural integrity, and that the purpose of the standard would be to reduce death and injuries resulting from the structural collapse of the bus body structure, the unintended opening of emergency exits, and the detachment of window glazing, seats, and overhead luggage racks.

Van Hool, TEMSA, and the ABA opposed the scope of the proposed requirements and test procedures. The commenters believed that the ECE R.66 test was appropriate for assessing the strength of the bus "superstructure" but that subsystems such as seats, overhead racks, emergency exits, and glazing should not be assessed under FMVSS No. 227. Those commenters, and Prevost, believed that the ECE R.66 rollover test is only designed for, and is capable only of, providing an evaluation of the bus superstructure strength.

ECE R.66 defines "superstructure" as "the load-bearing components of the bodywork as defined by the manufacturer, containing those coherent parts and elements which contribute to the strength and energy absorbing capability of the bodywork, and preserve the residual space in the rollover test." ECE R.66 requires that the superstructure of the bus must have sufficient strength to ensure that, during and after the rollover test, no part of the vehicle that is outside the survival space at the start of the test intrudes into the survival space during the test.

Agency Response

This final rule adopts the NPRM's proposed prohibition that no part of the bus that is outside the survival space shall intrude into the survival space, both during movement of the tilting platform or resulting from impact of the

bus on the impact surface.⁴⁶ However, after consideration of the comments, NHTSA has decided not to adopt the NPRM's proposal that each anchorage of an interior overhead luggage rack or other compartment must not completely separate from its mounting structure during movement of the tilting platform or resulting from impact of the bus on the impact surface or that seat anchorages not become dislodged during the test.

Under the NPRM, those proposed prohibitions would have applied even if the luggage rack does not enter the survival space, or the seat anchorages dislodge within the survival space. NHTSA has decided that the primary purpose of this rulemaking is to establish a roof strength and crush resistance standard that improves the resistance of the bus superstructure to deformation and intrusion, *i.e.*, by providing a survival space to occupants in rollovers. The purpose is achieved by prohibiting any structure, such as overhead luggage racks, from intruding into the survival space. By prohibiting overhead luggage racks from impeding into the survival space in the rollover, overhead luggage racks will have to be better anchored to the bus wall than they had been in the past, so that they do not detach and intrude into the survival space in the test. Thus, the proposed luggage rack provision is not needed to provide a survival space, since luggage racks are prohibited from intruding into the survival space. By being securely anchored so that they do not fall into the survival space, luggage racks will be less likely to impede egress in an emergency, or fall and cause head and neck injuries to occupants.

NHTSA has decided against adopting the NPRM's proposal that seat anchorages must not become dislodged during the test. The agency believes the seat anchorage provision is not necessary to achieve a survival space for occupants. NHTSA proposed the requirement for the retention of seat anchorages because of the agency's test of the MY 1991 Prevost LeMirage bus.⁴⁷ In the test, anchorages of a seat with a restrained mid-size adult male dummy completely separated from its bus attachment location, allowing the seat to fall across the bus with the restrained dummy attached to the seat. NHTSA believed at the NPRM stage that the

⁴⁶ In response to comments, however, the final rule permits detritus and other debris caused by the impact to fall into the survival space, such as small glazing pebbles or bolts and screws. The objects must not weigh more than 15.0 grams. This issue is discussed in detail below.

⁴⁷ A summary of the test may be found in the NPRM, *supra*, in section IV.b 79 FR 46100-46102.

failure of the seat anchorages during the rollover test presented a significant safety risk to restrained occupants in bus rollover events and reduced the effectiveness of seat belts.

However, after considering the comments and other information, NHTSA concludes a specific requirement in FMVSS No. 227 for seat anchorages to remain completely attached is unnecessary for several reasons. First, the seat anchorages in the MY 1991 Prevost LeMirage separated from the bus because the seat was bolted to unreinforced sheet metal of the bus sidewall. In NHTSA's test of the newer MY 2000 MCI bus Model 102-EL3, none of the seats anchorages failed—despite the fact that certain seats were ballasted with either a 150 lb anthropomorphic ballast or with 150 lb steel weights. That is, the seats remained attached even while tested under highly demanding conditions, with the ballasts attached to the seats. This test of the MY 2000 MCI bus demonstrates that bus seat anchorage designs have improved since the MY 1991 and 1992 buses NHTSA tested in its test program.

Second, it is likely the connectivity strength of seat anchorage designs have improved even more since the design of the MY 2000 bus because of the agency's 2013 final rule requiring lap/shoulder belts on all large buses. The final rule requires the lap/shoulder belts to be integral to the bus seats, and that the belt anchorage, together with the seat anchorage to the bus, meet the rigorous strength requirements of FMVSS No. 210, "Seat belt assembly anchorages" (49 CFR 571.210). FMVSS No. 210 requires seat anchorages, attachment hardware, and attachment bolts to withstand loads of 13,345 N (3,000 lb) applied simultaneously to the lap belt portion and the shoulder belt portion of the Type 2 restraint system. The seat anchorages of new large buses meeting FMVSS No. 210 will be reinforced over and beyond the design of a MY 2000 bus, which reduces the risk even further that the seats will detach from the bus structure in a rollover as had been observed in the tests of the MY 1991 and 1992 buses. Thus, adding a specific requirement in FMVSS No. 227 for the seat anchorages to remain completely attached duplicates the seat anchorage retention requirements of FMVSS No. 210.

The agency's bus rollover tests found that glazing panels vacated their window mountings during the rollover. In adopting the proposal that items outside of the survival space must not enter the survival space, this final rule prohibits large panes of glazing falling into the survival space from the non-

struck side of the bus and injuring occupants. Strengthening the structure of the bus and glazing mountings to resist the rollover crash forces that act to pop out window glazing is an important "portal improvement" to prevent partial and complete ejection of motorcoach passengers," as directed by MAP-21 section 32703(b)(2). Further, strengthening the frames is critical to rollover safety if the subject buses employ advanced glazing that mitigate the risk of occupant ejection in rollovers. NHTSA research into advanced glazing as a means of mitigating occupant ejection⁴⁸ revealed the need for significant improvement in the structural integrity of motorcoaches before the benefits of advanced glazing materials could be achieved. FMVSS No. 227's survival space requirement will help prevent glazing from popping out or otherwise detaching from its window mount and will help ensure the safety countermeasures are retained in the window frames in a crash.

This final rule adopts the requirement for emergency exits to remain closed. This requirement is beyond ECE R.66 but is needed to address concerns relevant to the U.S. NHTSA's bus rollover tests found that emergency exit windows and roof hatches opened during the rollover. NHTSA considers open emergency exits potential safety hazards, as open emergency exits create unsafe ejection portals during a rollover crash. Approximately two-thirds of the fatalities in bus rollover crashes in this country involve occupants ejected from the bus. Reducing the likelihood of ejections through these portals by upgrading latches and hinges will reduce the fatality risk in rollovers and conform to the mandate of MAP-21 section 32703(b)(2).

ABA states that NHTSA placed too much emphasis on preventing unbelted passenger ejection rather than on ensuring the integrity of the body structure. It also states that the FMVSS No. 227 requirements that are not in ECE R.66 replicate the benefits already achieved through the bus seat belt rule.

NHTSA does not agree that FMVSS No. 227 overemphasizes unbelted passengers. Passengers using seat belts, and those that do not, will benefit from the standard by being protected from collapsing bus structures or contact with loose heavy objects. The requirements of

FMVSS No. 227 supplement, and do not replicate, the agency's final rule on passenger seat belts. With belted passengers more likely to be retained in the bus interior because of the belts, FMVSS No. 227 improves the protective attributes of the occupant compartment in which they are retained. FMVSS No. 227 will benefit unbelted occupants by helping retain glazing in window frames and providing at least a minimum level of protection against dangerous structural collapse into the occupant compartment. The requirement that emergency exits remain closed during the rollover test increases the likelihood that emergency exits do not become ejection portals during rollover crashes, including crashes involving more than a quarter turn. These requirements will benefit belted and unbelted occupants, as keeping side window exits closed protects against partial ejection of belted occupants and partial and complete ejections of unbelted occupants, including children.

VIII. Applicability of the Rule

NHTSA proposed to apply FMVSS No. 227 to high-occupancy vehicles with an unreasonably high involvement in fatal rollovers, and on which Congress focused in MAP-21.⁴⁹ NHTSA proposed to apply FMVSS No. 227 to buses to which the agency's November 25, 2013 final rule on passenger seat belts applied.⁵⁰ NHTSA's view in the NPRM was that FMVSS No. 227 should apply to those buses with seat belts, so that a survival space could be provided to the belted occupants.⁵¹

The agency received a number of comments relating to the proposed applicability of FMVSS No. 227. Two commenters requested us to include medium-size buses (buses with a GVWR between 4,536–11,793 kg (10,000–26,000 lb), two suggested excluding

⁴⁹ MAP-21 Subtitle G, the "Motorcoach Enhanced Safety Act of 2012," defined "motorcoach" as having the meaning given the term "over-the-road bus" in section 3038(a)(3) of TEA-21 (49 U.S.C. 5310 note) but did not include a transit bus or a school bus. Under MAP-21, an over-the-road bus is a bus characterized by an elevated passenger deck located over a baggage compartment.

⁵⁰ NHTSA's seat belt rule applied to all new over-the-road buses regardless of GVWR, including transit buses, prison buses, and perimeter-seating buses). The rule also applied to non-OTRBs that have a GVWR greater than 11,793 kg (26,000 lb), except for non-OTRB transit buses, prison buses, and perimeter-seating buses. The seat belt rule did not apply to school buses.

⁵¹ The proposed rollover structural integrity requirements applied to all new over-the-road buses regardless of GVWR (except for school buses). The rule also applied to all new non-OTRBs with a GVWR greater than 11,793 kg (26,000 lb), except for school buses, transit buses, and perimeter-seating buses.

⁴⁸ Martec Limited, "Motorcoach Glazing Retention Test Development For Occupant Impact During a Rollover," August 2006; Docket No. NHTSA-2002-11876-0015. Among other things, this research found that advanced glazing, such as laminate glazing, could pop out of its mounting due to torsional deformation of the structure around the window.

entertainer buses, one suggested excluding prison transport buses and another suggested excluding double-decker buses.

a. Medium-Size Buses (Buses With a GVWR of 4,536 to 11,793 kg (10,000–26,000 lb))

In the NPRM, NHTSA proposed not applying FMVSS No. 227 to medium-size buses. NHTSA based the decision on an analysis of crash data for medium-size buses. The agency examined 2000–2009 FARS data showing 42 occupant fatalities in buses with a GVWR between 4,536–11,793 kg (10,000–26,000 lb), of which 24 fatalities were a result of 13 rollover crashes. Over the ten-year period between 2000–2009, medium-size buses were associated with an average of 1.3 rollover crashes per year and 2.4 fatalities per year. In contrast, there was an average of 3.2 rollover crashes annually among large buses (OTRBs and non-OTRBs with a GVWR greater than 11,793 kg (26,000 lb)). These large bus rollover crashes resulted in an average of 11.4 fatalities per year. Among all fatalities occurring in rollover crashes in buses coded in FARS as “cross-country,” “other,” and “unknown” with a GVWR greater than 4,536 kg (10,000 lb), 83 percent were in buses with a GVWR greater than 11,793 kg (26,000 lb).

Two commenters (NTSB, CIAL) disagreed with the agency and commented that NHTSA should include medium-sized buses in the applicability of FMVSS No. 227.⁵²

NTSB Comment

NTSB commented that medium-size buses are often used in a similar fashion as motorcoaches with GVWRs over 11,793 kg (26,000 lb). It disagreed with the data analysis in the NPRM showing that medium-size buses do not have the same crash involvement as OTRBs and non-OTRBs with a GVWR over 11,793 kg (26,000 lb). NTSB stated that FARS has coding issues that may result in undercounting fatalities for the medium-size bus type. It references several crashes that it believes were not counted in the FARS database and suggest that the University of Michigan’s Buses Involved in Fatal Accidents (BIFA) database has a more accurate classification of crashes.

Agency Response

NTSB correctly pointed out that we had not included the data that NTSB discussed in its comment. We have updated our FARS data analysis on medium-size buses to include these data. Even with the adjustment, however, our analyses find that medium-size buses do not pose a sufficient safety need to warrant application of FMVSS No. 227 to the buses.

After NTSB commented, NHTSA carefully reexamined and updated FARS data to determine whether the agency under-counted the medium-size bus fatalities. We specifically used FARS data from 2004 to 2018 to ascertain the fatalities attributable to medium-size buses.

FARS has five relevant categories for medium-size buses that are non-OTRBs: “other bus,” “unknown bus,” “van-based bus,” “school bus,” and “transit bus.” Due to the intended scope of this rulemaking, NHTSA focused on only the first three categories.

To assure the dataset was complete, NHTSA also reexamined the FARS body types to check to make sure all medium-size buses were included in the analysis. There had been a change in FARS body codes in 2010. Prior to 2010, van-based buses with GVWRs less than or equal to 10,000 lb were coded as body type code 21, “large van.” In 2010, body code 55 was added to the FARS coding manual (van-based bus with a GVWR greater than 4,536 kg (10,000 lb)). With that change, NHTSA considered whether, for the FARS data files before 2010, it was possible that some van-based buses with a GVWR greater than 4,536 kg (10,000 lb) were classified under body code 21. Consequently, NHTSA searched for crashes involving body code 21 with a GVWR greater than 10,000 lb and with a bus use codes of “intercity,” “charter/tour,” “transit/commuter,” “shuttle”⁵³ to see if there were any other rollover crashes involving types of vehicles that could be considered “medium-size buses.” We identified three rollover crashes, as shown in Table 9 below.

Table 9 below shows the number of medium-size bus crashes with a fatality, over a fifteen-year period.

TABLE 9—FATAL BUS OCCUPANT CRASHES OF MEDIUM-SIZE BUSES (GVWR 10,000 LB TO 26,000 LB) THAT ARE NON-OTRBs, BY THE BODY TYPE AND THE CRASH MODE [FARS 2004–2018]

Body type	Rollover	Frontal	Side	Rear	Total
Other bus	7	8	3	1	19
Unknown bus	3	2	0	0	5
Van-based bus	9	20	8	2	39
Large van (used as intercity, tour, commuter, or shuttle buses)	3	6	5	2	16
Total	22	36	16	5	79

The data show that there were 79 fatal medium-size bus crashes between 2004 and 2018, of which 22 of the 79 crashes were rollover crashes. For the purposes of determining the safety need of applying FMVSS No. 227 to medium-size buses, NHTSA will focus only on

rollover crashes, as the harm the standard is intended to address, and the countermeasures that will be installed pursuant to that harm, only result from rollovers.

Table 10, below, shows the total number of medium-size bus fatalities attributable to various crash types.

⁵² While CIAL focused on paratransit medium-size buses, it requests applying FMVSS No. 227 to all medium-size buses. Further, as its comment does show that paratransit buses have a different safety concern compared other medium-size buses, we are responding to the comment about the whole

weight class rather than specifically regarding paratransit buses only.

⁵³ FARS has bus use categories of not a bus, school, intercity, charter/tour, transit/commuter, shuttle, modified for personal/private use, not

reported, and unknown. Among these bus use categories, the large vans that were used as charter/tour, intercity, commuter, and shuttle were relevant to this rulemaking. Therefore, only the large vans with these bus use codes were included.

TABLE 10—FATALITIES IN MEDIUM-SIZE BUSES BY BODY TYPE, CRASH MODE, AND OCCUPANT TYPE [FARS 2004–2018]

Body type	Rollover		Front		Side		Rear		All types		Total
	Driv	Pass	Driv	Pass	Driv	Pass	Driv	Pass	Driv	Pass	
Other bus	1	18	5	7	1	2	0	1	7	28	35
Unknown bus	0	6	1	1	0	0	0	0	1	7	8
Van-based bus	4	7	12	28	1	8	1	1	18	44	66
Large van (used as intercity, tour, commuter, or shuttle buses)	1	8	3	7	0	7	1	2	5	24	29
Total (above)	6	39	21	43	2	17	2	4	31	103	134

For the three relevant medium-size bus types and the large vans used as buses, there were 45 total fatalities (6 driver fatalities and 39 passenger fatalities) in rollover crashes for the fifteen-year period. Over the 15-year period 2004–2018, there were an average of 1.5 fatal medium-size bus rollover crashes, with an average of 3.0 bus occupant fatalities per year. These values are small compared to those of large buses. According to data from FARS 2004–2018, there was an average of 3.7 fatal rollover crashes involving large buses (GVWR greater than 11,793 kg (26,000 lb)) (including OTRBs), resulting in an average of 11.7 occupant fatalities per year. There are significantly higher average rates of

annual fatal crashes and fatalities for large buses compared to medium-size buses.

While the average rates of annual fatal crashes and fatalities for large buses are significantly higher than those of medium-size buses, the fleet size of large buses is significantly smaller than that of medium-size buses. There are an estimated 2,200 large buses (GVWR greater than 11,793 kg (26,000 lb)) (including OTRBs) produced annually, compared to approximately 15,000 buses with a GVWR between 4,536–11,793 kg (10,000–26,000 lb) produced annually.⁵⁴ Table 11, below, summarizes these figures.

These data mean that there is a considerable disparity between the fatal

rollover crash involvement for large buses versus medium-size buses. Not only are large buses involved in more than twice as many rollover crashes on average annually, they also have about four times the number of occupant fatalities annually in rollover crashes than medium-size buses. Further, taking into consideration the almost seven-fold difference in annual production between large buses and medium-size buses (the annual production of large buses is about 1/7th of the annual production of medium-size buses), the safety need for FMVSS No. 227 is substantially higher for large buses than for medium-size buses.

TABLE 11—SUMMARY STATISTICS FOR FATAL ROLLOVER CRASHES AND OCCUPANT FATALITIES FOR LARGE BUSES (INCLUDING ALL OTRBs) AND MEDIUM-SIZE BUSES [From 2004 to 2018 (FARS)]

Bus size	Avg. annual rollover crashes	Avg. annual rollover fatalities	Avg. annual fleet sales
Large Bus (greater than 26,000 lb GVWR) and all OTRBs	3.7	11.7	2,200
Medium-Size Bus (GVWR of 10,000–26,000 lb)	1.5	3.0	15,000

With regard to the question whether there is a safety need to apply FMVSS No. 227 to medium-size buses, NHTSA's answer is no, the data do not show such a need at this time. The difference between the fatal rollover crash involvement between large and medium-size buses may be attributable to medium-size bus designs (e.g., medium-size buses may have a lower center of gravity compared to heavy buses, affecting crash involvement and/or severity, or have better vehicle controllability for a variety of reasons), or may reflect a difference in how the buses are used. Regardless, the data dissuade NHTSA from applying FMVSS No. 227 in a one-size-fits-all manner to all buses. NHTSA concludes there is not

a substantial safety need to apply the standard to medium-size buses.

NHTSA does not concur with NTSB's view that the BIFA database provides more relevant statistics than NHTSA's database. The BIFA database only includes data up to 2010, and so more recent crash data are not available. Since 2010, NHTSA has improved the accuracy of its crash data collection on buses and has expanded the bus category to include van-based buses. NHTSA's updated analysis using the FARS data files more accurately includes the mid-size bus crash information.

NTSB stated that the statistics from BIFA indicate that 128 medium-size buses were involved in fatal crashes,

resulting in 58 occupant fatalities between 2000–2009. This information does not show whether these crashes were rollover crashes (the crashes relevant to this rulemaking), or whether the 58 occupants were killed in rollovers. Despite the lack of specific data about the nature and severity of the crashes, NHTSA undertook an analysis assuming that all the crashes NTSB referenced were rollover crashes, and that all 58 fatalities were attributable to rollovers. NHTSA found that, even with this assumption, the data still show a large disparity between the rollover crashes associated with large buses versus medium-size buses. Even if all 58 fatalities were attributable to rollover crashes, such crashes would contribute

⁵⁴ Evaluation of the Market for Small-to-Medium-Sized Cutaway Buses, Federal Transit Administration Project#: M1–26–7208.07.1,

December 2007, available at <https://www.transit.dot.gov/sites/fta.dot.gov/files/docs/AnEvaluationofMarketforSmalltoMediumSized>

CutawayBuses.pdf, last accessed November 04, 2016.

to, on average, 5.8 deaths annually (58 fatalities/10 years). In this hypothetical scenario, large buses would still be associated with 1.3 times the number of fatalities compared to medium-size buses each year—while the annual production of large buses would continue to be around 1/7th of the annual production of medium-size buses. Thus, even when factoring in the crash data suggested by NTSB and making assumptions about the data that likely includes more crashes and fatalities than actually occurred in medium-size buses, the data again show an absence of a safety need for applying FMVSS No. 227 to medium-size buses.

For the reasons above and in the NPRM, NHTSA declines to extend FMVSS No. 227 to medium-size buses.

CIAL Comment

CIAL argued that the proposed standard should apply to medium-size paratransit buses because buses meeting the proposed standard would be safer for passengers. It indicated it has been researching medium-size paratransit buses designed to meet FMVSS No. 220⁵⁵ and found that buses meeting FMVSS No. 220 fail a dynamic rollover test based “on the concept of survival space.” The commenter stated that six buses it tested showed a failure mode “in which a weak frontal structure allowed for excessive deformation to occur in the front portion of the bus body.”

Agency Response

NHTSA declines to make the suggested change. CIAL’s comment did not provide a basis to conclude there is a safety need to adopt the FMVSS No. 227 test for medium-size buses. (See response, above, to NTSB on this issue.) CIAL states that its evaluation using finite element models of medium-size paratransit buses shows that paratransit buses meeting FMVSS No. 220 failed to meet a “survival space” criterion of a Florida state vehicle standard. While CIAL’s comparison of the performance of paratransit buses under the requirements in FMVSS No. 220 and ECE R.66 was based on simulations, NHTSA conducted the physical tests specified in the two standards on the same large bus models. NHTSA’s rollover testing of motorcoaches indicated that large buses that did not meet the ECE R.66 survival space requirement also failed the FMVSS No. 220 requirements.

⁵⁵ The requirements in FMVSS No. 220 apply to school buses. The test in FMVSS No. 220 places a uniformly distributed vertical force pushing directly downward on the top of the bus with a platen.

Additionally, as noted earlier, over the 15-year period 2004–2018, there were an average of 1.5 fatal medium-size bus rollover crashes, with an average of 3 bus occupant fatalities per year. These data apply to all medium-size buses and therefore, the average annual number of rollover crashes and fatalities associated with medium-size paratransit buses would be extremely small. The fact that the vehicles did not meet the survival space criterion is not commensurate with a need to apply FMVSS No. 227 to the vehicle type at the FMVSS level. We decline to make the requested change, for the reasons provided above and in the NPRM.

b. Large Buses

Entertainer Buses

NHTSA proposed to apply FMVSS No. 227 to all OTRBs as they were defined in MAP–21. In doing so, NHTSA intended to cover all the buses Congress directed the agency to address in MAP–21, regardless of GVWR.

Comments Received

Hemphill and NiteTrain, manufacturers and operators of over-the-road entertainer buses, expressed concern about the test burdens on small final-stage manufacturers of these vehicles, and suggested excluding entertainer buses from the standard. Prevost, a manufacturer of both complete motorcoaches and incomplete vehicles (“shells”), also commented in favor of excluding entertainer buses. According to Hemphill and NiteTrain, their entertainer buses are built from incomplete bus shells purchased from Prevost. The shells consist of the window exits, roof exits, sidewall, and roof structure.

NiteTrain and Hemphill stated that since they do not alter the safety structure of their purchased motorcoach shells, any compliance with the new standard should be the responsibility of the shell manufacturer. ABA commented that NHTSA should consider entertainer buses a distinct type of motor vehicle and decide “on a case-by-case basis, the extent to which each element of the motorcoach safety requirements should be made applicable.”

Agency Response

NHTSA has decided not to apply FMVSS No. 227 to over-the-road perimeter-seating buses. The agency’s decision to scale back the scope of FMVSS No. 227 is based on an analysis of safety need, and not on a finding that small manufacturers cannot certify compliance with the standard. There are

ways small manufacturers may certify to FMVSS No. 227 that would not impose undue burdens on the manufacturers. For a discussion of those options, see the August 6, 2014 NPRM preceding this final rule (79 FR 46116–46117), and the Regulatory Flexibility Act analysis below in this final rule.

Instead, NHTSA has reassessed the need to apply FMVSS No. 227 to OTRBs with perimeter seating after considering that non-OTRBs with perimeter seating are excluded from the standard. NHTSA does not find a reason to distinguish between OTRB with perimeter seating and non-OTRB with perimeter seating, when the safety data indicate no relevant differences between the vehicles based on safety need. OTRB with perimeter seating do not present a greater risk of injury due to the failure of the structural integrity of the buses compared to non-OTRBs with perimeter seating.

Section 32703(a) of MAP–21 mandated NHTSA to prescribe a seat belt rule for lap/shoulder belts for motorcoaches (*i.e.*, which MAP–21 basically defined as over-the-road buses, except transit buses and school buses) and did not provide NHTSA discretion in applying the requirement. Thus, the 2013 seat belt rule issued pursuant to section 32703(a) applied uniformly to all over-the-road buses. NHTSA also applied the rule to non-OTRBs, but had discretion to draw distinctions among buses in that bus category, as appropriate. NHTSA drew on that discretion to design a rule that excluded non-OTRBs with perimeter seating from the belt requirement, based on an absence of a safety need for the belts.

NHTSA drafted the FMVSS No. 227 NPRM preceding this final rule to apply the proposed structural integrity requirements to the buses that were subject to the lap/shoulder belt requirements adopted by the 2013 MAP–21 final rule. The agency believed that there was a need to ensure enhanced structural integrity of the interior of buses subject to the seat belt rule, to better protect the restrained occupants who, due to the belts, will be retained in the bus interior.⁵⁶ The NPRM excluded from proposed FMVSS No. 227 perimeter seating buses, but not if they were OTRBs.⁵⁷

⁵⁶ 79 FR 46096, col. 1.

⁵⁷ The proposed definition of “perimeter-seating bus” is “a bus with 7 or fewer designated seating positions rearward of the driver’s seating position that are forward-facing or can convert to forward-facing without the use of tools and is not an over-the-road bus.” (S3.) NHTSA excluded perimeter-seating buses that were not over-the-road buses from the seat belt rule because perimeter-seating buses are often used in shuttle operations.

However, after considering the comments, NHTSA has decided not to apply FMVSS No. 227 to perimeter-seating buses as a class. In the seat belt final rule, NHTSA applied the belt requirement to OTRBs with perimeter seating, and not to non-OTRB with perimeter seating, because of a statutory mandate to require the seat belts in *all* OTRBs. There is no such mandate about the applicability of FMVSS No. 227. NHTSA has discretion under MAP-21 (section 32703(b)) to determine whether a rollover structural integrity standard and an anti-ejection portal improvement standard meet the requirements and considerations of section 30111(a) and (b) of the Safety Act.⁵⁸ After considering section 30111(a) and (b), NHTSA has decided it would not be appropriate to distinguish between perimeter-seating buses depending only on whether they are OTRBs or not.

NHTSA developed its motorcoach safety plan to protect the public against unreasonable risk of death or injury in high-occupancy vehicles.⁵⁹ In the Executive Summary in NHTSA's 2013 seat belt final rule, NHTSA stated: "One of the guiding principles NHTSA considers in determining the priorities of our rulemaking projects is to protect the public against unreasonable risk of death or injury in high-occupancy vehicles. In 2007, NHTSA published a comprehensive plan to research improvements to bus safety, entitled, 'NHTSA's Approach to Motorcoach Safety.'" [Footnote omitted.] In contrast, perimeter-seating OTRBs are low-occupancy vehicles compared to conventional inter-city buses that have primarily forward-facing seating. NHTSA has decided to exclude both OTRBs with perimeter-seating and non-OTRBs with perimeter-seating from this final rule, based on an absence of a safety need to include the buses. It is reasonable not to distinguish between the two kinds of perimeter-seating buses in applying the standard to the vehicles because of an absence of reasons to distinguish. This final rule treats both

kinds of buses with perimeter seating (OTRB and non-OTRB) the same under FMVSS No. 227.

It should be noted that Hemphill and NiteTrain indicate that they obtain a bus "shell" from an incomplete vehicle manufacturer, such as Prevost.⁶⁰ Prevost manufactures both complete motorcoaches and incomplete vehicles ("shells"). The agency believes that, following establishment of this FMVSS No. 227, Prevost will offer for sale in the U.S. incomplete vehicle shells that meet the structural integrity requirements of ECE R.66 (the standard on which FMVSS No. 227 is based), because most of their final-stage manufacturer customers will produce buses that are subject to FMVSS No. 227. For customers that produce buses that are excluded from FMVSS No. 227, for liability and competitive marketing reasons, it would make little commercial sense to offer shells that do not meet ECE R. 66 to customers, or for customers to buy such shells. Thus, even if perimeter-seating buses are excluded from FMVSS No. 227, manufacturers will likely produce buses using these ECE R.66 shells, which will result in vehicles that provide significantly improved structural integrity in a rollover crash. When the bus superstructure is strengthened to meet FMVSS No. 227 there will be less deformation of the bus structure and reduced torsional loads on interior structures, such as partitions, and reduced risk of intrusion into the occupant space. This means that perimeter-seating buses, even though excluded from the standard, will provide enhanced structural integrity in a rollover. Hemphill commented that partitions will "add support to the roof of our coaches and significantly increase the roof's integrity" and will "significantly reduce any intrusion into the survival space" in a rollover. While the commenter did not provide data or evidence to support its claim, NHTSA concurs that minor modifications to the vehicle structure, such as by installation of partitions, will not degrade the integrity of the superstructure of the bus, and that even these perimeter-seating buses will provide protection against roof collapse in a rollover.

Prison Transport Buses

The NPRM proposed to apply FMVSS No. 227 to prison transport buses (78 FR 70416). MCI, a manufacturer of prison transport buses, disagreed with this proposal. MCI expressed concern about the need to partition these buses to

provide cells, believing that each customer's unique cell configuration could affect the test results of the standard. MCI states it would not be practicable to fulfill a one-of-a-kind bus order by building a second bus for testing to meet MCI's certification responsibilities.

Agency Response

NHTSA agrees to exclude prison buses from FMVSS No. 227 but not for the reason given by MCI. Due to the nature of the vehicle type, prison vehicle interior configurations/partitions may vary considerably. However, NHTSA does not require the kind of certification burden MCI describes. A manufacturer does not have to build a replicate vehicle to test to enable the manufacturer to certify compliance with the standard. A discussion of various certification methods available to manufacturers can be found in the August 6, 2014 NPRM preceding this final rule (79 FR 46116-46117), and in the Regulatory Flexibility Act analysis below in this final rule.

NHTSA is excluding prison buses because the FMVSS No. 227 is not appropriate for the bus type. The agency does not know how many prison buses are manufactured each year, but does not believe there is a substantial number of such vehicles produced. Regardless of the number of vehicles produced, bus superstructures sold in the U.S. are likely to be strengthened to meet FMVSS No. 227 after this final rule becomes effective. With the strengthened superstructures, there will be less deformation of the bus structure and reduced torsional loads on interior structures, such as partitions. Thus, the agency has not found justification to apply FMVSS No. 227 to prison buses, as minor modifications to the vehicle structure, such as by installation of partitions, are unlikely to affect the structural integrity of the vehicles.

Double-Decker Buses

The NPRM proposed to apply FMVSS No. 227 to double-decker buses. Buses with open-roof sections would not have the open section assessed for compliance but the closed-roof sections would be. Double-decker buses with closed-roof sections on the lower and top levels would have both levels assessed for compliance. Since we saw no difference in the potential safety risks of double-decker buses and other large buses covered under our proposal, we proposed applying FMVSS No. 227 to the bus type.

⁵⁸ NHTSA is authorized under the Vehicle Safety Act to issue motor vehicle safety standards that "shall be practicable, meet the need for motor vehicle safety, and be stated in objective terms" (49 U.S.C. 30111(a)). When prescribing a motor vehicle safety standard, NHTSA considers, *inter alia*, relevant available motor vehicle safety information, whether a standard is reasonable, practicable, and appropriate for the particular type of motor vehicle or motor vehicle equipment for which it is prescribed, and the extent to which the standard will carry out the purpose and policy of the Act, *i.e.*, reduce traffic accidents and deaths and injuries resulting from traffic accidents (49 U.S.C. 30111(b)).

⁵⁹ 78 FR 70416, November 25, 2013. The preamble also makes repeated reference to "high-occupancy" buses in its analyses of crash data involving the subject buses.

⁶⁰ Incomplete vehicle manufacturers such as Prevost are large manufacturers.

Comments Received

NTSB and Coach USA (a large motorcoach operator) supported applying FMVSS No. 227 to double-decker buses. NTSB stated it would be appropriate to test the portions of the bus where bus structure could intrude on the vehicle occupants. Coach USA supported applying the same requirements to lower/enclosed sections of open-top double-decker buses, and stated that its double-decker buses already comply with the ECE R.66 test. In contrast, Van Hool stated that in Europe ECE R.66 can be applied to double-deckers only at the request of the manufacturer and referenced a document to argue that the number of fatalities that are attributable to double-decker buses is lower than those attributable to other buses.

Agency Response

This final rule applies FMVSS No. 227 to double-decker buses as proposed. Double-decker buses are being used for intercity/interstate transport of large numbers of passengers.⁶¹

We do not concur with Van Hool that there should not be a safety concern with double-decker buses. The document that Van Hool referenced to support its view consists only of meeting notes from a UN ECE informal working group meeting on ECE R.66.⁶² The meeting notes stated that a representative from Spain presented information about bus crashes, but the notes did not include statistics about double-decker buses. Further, the notes included a point made by a person from the International Road and Transport Union expressing concern that the increased mass of the superstructure of a double-decker bus above the vehicle's center of gravity might suggest that the double-decker bus should be subject to the ECE R.66 requirements. We do not see any information in the meeting notes that suggested that the safety risk is lower for these types of buses.

Further, we believe that the design characteristics and physics of double-decker buses suggest that double-decker buses are at least as susceptible to the rollover crash risk as the other buses covered under this final rule. Double-decker buses can have GVWRs fifteen to twenty percent greater than single-deck

OTRBs.⁶³ A Swedish study⁶⁴ on occupant fatalities in bus crashes concluded that—

The height of a double-deck vehicle may be 60–80 [centimeters] higher than a corresponding single deck vehicle. In case of a rollover with a double-deck vehicle, the greater [the] distance from the [center] of gravity in the upper compartment[,] the greater [the] increase of the rotation velocity. This, in turn, will increase the [ground] impact [leading to] greater risk for injuries as a consequence.

Thus, the available information does not support Van Hool's contention that there is little crash risk associated with double-decker buses. While the agency seeks to harmonize with ECE regulations to the extent possible, we believe applying FMVSS No. 227 to double-decker buses will meet a safety need in this country. According to Coach USA, its double-decker buses already meet the ECE R.66 requirements, which illustrates the practicability of the buses" meeting FMVSS No. 227.

This final rule makes a slight clarification in the regulatory text of FMVSS No. 227 relating to double-decker buses. The standard would not apply to a level of a bus that does not have a permanent roof over the level, such as the upper level of a double-decker bus that does not have a permanent roof over the upper level. However, a double-decker bus that is open-top in the rear half of the bus but permanently closed-top for the front half of the bus is subject to the requirements of FMVSS No. 227 for the front half of the top of the bus (as well as for the entire enclosed lower section of the bus).

IX. School Bus Derivative Buses

Daimler Trucks North America (DTNA)⁶⁵ and IC Bus, LLC (IC Bus) manufacture school and commercial buses and certify the vehicles to FMVSS No. 220, "School bus rollover protection," and FMVSS No. 221, "School bus body joint strength." The commenters suggest that NHTSA permit buses meeting FMVSS No. 221 the option of meeting FMVSS No. 220 rather than FMVSS No. 227. They state that the buses are similar in appearance to school buses but are sold for non-school related purposes. The

commenters contend that the operating environment for these buses is closer to that of school buses than intercity buses and that the vehicles should be subject to the school bus safety standards for rollover protection (FMVSS No. 220) and joint strength (FMVSS No. 221) rather than FMVSS No. 227.

Agency Response

We agree with the commenters and have excluded school bus derivative buses from FMVSS No. 227. This is because the buses already provide a survival space by meeting FMVSS No. 220, "School bus rollover protection," and do not need to meet the requirements of FMVSS No. 227.

FMVSS No. 227 defines "school bus derivative buses" in a manner reflecting that the buses are built on a school bus platform for sale in the U.S. The buses have safety systems that are identical to school buses regarding their fuel systems, bus body joint strength, emergency exits and roof crush resistance. The vehicles could be certified as meeting the FMVSSs for "school buses" if they had seating systems meeting FMVSS No. 222, "School bus seating and passenger protection" (49 CFR 571.222), and school bus lights and stop arms meeting FMVSS No. 108 and No. 131, respectively. NHTSA is excluding the buses to avoid redundancy in the FMVSSs. Thus, the definition is designed to exclude only vehicles that could be certified to the school bus FMVSSs and not other large buses.

DTNA and IC Bus argue that their school bus derived commercial buses operate under conditions more similar to those of school buses than OTRBs. The "applications" in which the commercial buses are used are described by DTNA as "church activity, retirement community, college campus, boys and girls club, parks and recreation department and airport shuttles." IC Bus echoes that description and adds "support of emergency responders." NHTSA agrees that these applications describe usage that is more local in nature than that of intercity OTRBs. NHTSA recognizes, however, that once purchased, operators of the vehicles could use school bus-derivative buses in ways other than that described by DTNA and IC Bus, so in analyzing the commenters' suggestion NHTSA must consider the likelihood that the buses may not be used like school buses.

It is a fact that FMVSS No. 220 has a record of rollover safety in school buses. The standard has been applied to school buses since 1977. School bus derivative buses are already manufactured to meet the school bus roof crush resistance

⁶¹ See e.g., Megabus website, <http://us.megabus.com/>, last accessed October 24, 2016.

⁶² <https://www.unece.org/fileadmin/DAM/trans/doc/2008/wp29grsg/GRSG-95-07e.pdf> (last accessed Feb-23-2017).

⁶³ Van Hool TX Luxury Touring Coach GVWRs are 50,700 lb (40" vehicle length) and 54,000 lb (45" vehicle length). Van Hool TD925 double-decker buses are GVWR 62,000 lb (45" vehicle length). Vehicle data from <https://www.abc-companies.com/>, last accessed October 24, 2016.

⁶⁴ Albertsson, Pontus; Occupant Casualties In Bus And Coach Traffic; 2005; ISBN 91-7305-829-7.

⁶⁵ DTNA states that it manufactures school buses under the Thomas Built Bus brand.

requirements in FMVSS No. 220. NHTSA believes these buses already have improved roofs and roof supports that substantially improve the resistance of the roofs to deformation and intrusion compared to buses that do not meet FMVSS No. 220.⁶⁶ To avoid redundancy in the FMVSSs, this final rule permits these buses the option of meeting FMVSS No. 220 when tested in accordance with the test procedures of FMVSS No. 220, instead of the ECE R.66-based rollover test requirements of FMVSS No. 227.

The agency is not permitting buses other than school bus derivative buses to meet FMVSS No. 220. Buses other than school bus derivative buses have been designed such that they have a higher center of gravity and/or utilize larger windows than school buses. These characteristics can lead to a higher incidence of occupant ejections during rollovers. Thus, the dynamic rollover test in ECE R.66 affords the agency an opportunity to set a minimum level of performance for the ejection-mitigating features of non-school bus derivative buses, such as emergency exits closure and side window glazing retention during a rollover crash.

X. Performance Requirements

The NPRM proposed performance requirements that buses must meet when subjected to a tilt rollover test. In the proposed test, the bus is placed on a tilting platform that is 800 mm (31.50 inches) above a smooth and level concrete surface. One side of the tilting platform along the length of the vehicle is raised at a steady rate of not more than 5 degrees/second until the vehicle becomes unstable, rolls off the platform, and impacts the concrete surface below with its roof leading edge. The major points of this testing method involve a quarter-turn roll of the bus onto its side (so that it strikes the top corner of the bus superstructure on a rigid surface) and ballasting the vehicle to simulate the load that the bus would be carrying in a rollover crash. This test creates a high-severity test condition that encompasses the majority of real-world bus rollovers.

⁶⁶ In addition, as DTNA and IC Bus point out, the vehicles also meet FMVSS No. 221, which adds to the structural integrity of the vehicles. The purpose of FMVSS No. 221 is to reduce deaths and injuries resulting from the structural collapse of school bus bodies in crashes.

a. Severity of the Rollover Test

EPGAA, Advocates, the families of bus crash victims (the families), and Ms. Stoos, express concern that the proposed test evaluation is not severe enough to replicate the conditions of real-world bus rollovers. The families and Advocates state that the rollover test should include: Vehicle rollovers greater than 90 degrees (one quarter roll); high vehicle speed prior to rollover; embankments; and impacts that may occur after the rollover. Advocates references a 2007 glazing retention test development study commissioned by NHTSA and Transport Canada to illustrate its point (“Motor Coach Glazing Retention Test Development For Occupant Impact During A Rollover,” Martec Technical Report # TR-06-16, Rev 4, August 2006 (“Martec study”)⁶⁷).

Agency Response

NHTSA does not agree with the commenters’ argument that FMVSS No. 227’s test is not a reasonable representation of a severe rollover crash. As discussed below, research papers, test reports, simulation analyses, and reports on the efficacy of the ECE R.66 test support the implementation of the test.

FMVSS No. 227’s test is highly stringent, accounting for the potential real-world rollover crash forces that are imparted on the bus superstructure in a rollover crash. The test creates a force near the top corner of the bus in the transition from the sidewall to the roof. This application of force is representative of a bus rolling over into a drainage ditch along a highway; however, in the FMVSS No. 227 test, the bus strikes a hard surface that is more rigid than the typical earthen drainage ditches along the roadside. The hard surface results in the energy from the rollover being absorbed by the bus and not shared between the bus and the ground. This hard surface contact makes FMVSS No. 227’s rollover test more stringent than similar rollovers into earthen embankments. Matolcsy, M. (2007), “The Severity of Bus Rollover Accidents,” 20th International Technical Conference for the Enhanced Safety of Vehicles, Paper 989, Lyon,

⁶⁷ Docket No. NHTSA-2002-11876-0015.

France.⁶⁸ The test also gives the agency a repeatable, reproducible, and practical method to evaluate bus structural integrity during rollover crashes.

It can appear to the eye that crashes involving multiple quarter-turn rolls along the ground are more severe than a single quarter-turn rollover onto rigid pavement that ends instantly, all other things being equal. The significant difference is that the multiple quarter-turn roll loads an entire side, then the roof, then the other side, next the wheels/suspension/floor, and so on until the bus comes to a rest. The multiple quarter-turn rollover dissipates the crash energy across major portions of the vehicle structure over a relatively long duration. The vehicle structure in a multiple quarter-turn crash is not managing or absorbing all of the crash energy at once. Single quarter-turn rollovers, in which the crash forces are reacted over a short duration by relatively weak localized components of the vehicle structure, require the entire vehicle structure to be stronger. Therefore, the more stringent rollover test is one in which the energy of the crash is applied instantaneously, such that the vehicle needs to manage and absorb all the energy applied at the same time.

The demanding nature of the ECE R.66 test incorporated into FMVSS No. 227 is discussed at length in the 2007 report, which evaluated the sufficiency of the test for adoption into R.66.⁶⁹ The report’s author notes that early work on ECE R.66 considered different types of rollover scenarios during deliberations to “find an appropriate standard approval rollover test.” For the issue of conducting a test with multiple turns (*i.e.*, the bus rolling more than a quarter-turn), the study concluded that the ECE R.66-based test imparts more loads on the bus superstructure than other potential tests that included multiple turns. This was found even though the tests with multiple turns began with a bus raised higher from its final end of test resting place—*i.e.*, the other tests began with greater potential energy than the ECE R.66-based test.

Figure 3, below, shows the three rollover tests that were analyzed during development of ECE R.66.

⁶⁸ Available at: <https://www-esv.nhtsa.dot.gov/Proceedings/20/07-0152-O.pdf>.

⁶⁹ Matolcsy, M. (2007), *supra*.

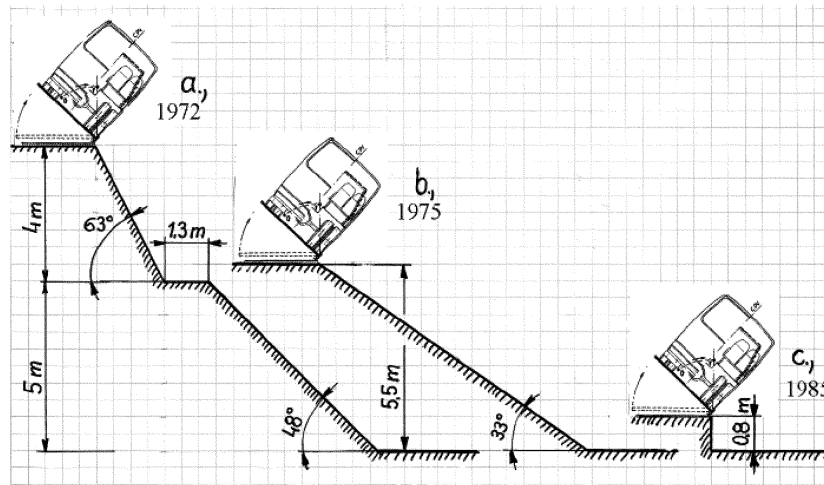

Figure 3: Three different rollover tests Hungary⁷⁰ evaluated for ECE R.66 development.

Test conditions “a” and “b” produce an initial contact between the bus and ground that may distribute the crash load into more of the bus sidewall structure than test condition “c.” Test condition “c” concentrates the initial rollover impact load into the upper outer corner of the bus superstructure.

The study compared the quarter-turn ECE R.66 test to other tests in which the bus traveled a greater distance during the test and rolled multiple times. The research conducted a series of tests under three test scenarios using the same bus type. In the end, the research showed test “c,” which is essentially ECE R.66, produced results that imparted the greatest loads on the bus superstructure. The test series further showed that bus reinforcements to provide survival space in test “b” needed further reinforcement to provide sufficient survival space in test “c.” From these data, it was found that, while a test could simulate a crash with more total energy (e.g., test conditions “a” and “b” under which the bus begins the test with higher potential energy), the long dissipation of that energy over multiple rolls during the crash significantly reduces the damage imparted to the bus superstructure during the test.

NTSB and Advocates request that the agency consider a test involving more than a quarter-turn rollover. The commenters did not elaborate on how many more turns of a vehicle rollover they would like the agency to adopt. The agency has no data on the number of quarter-turns that occur in a bus rollover since the FARS database does not capture that crash detail. Nonetheless, the Matolcsy report, *supra*, explains how buses developed to meet the requirements of ECE R.66 have maintained survival space when those

buses have experienced rollovers beyond a quarter-turn and down embankments. This information suggests that FMVSS No. 227 will lead to buses capable of providing bus passengers with a survival space and lowered risk of ejection during rollover crashes greater than a quarter-turn.

The Matolcsy report provides additional examples of real-world improvements manufacturers have made to buses in response to ECE R.66 requirements, including photographs of how bus interior compartments looked post-crash before and after application of ECE R.66 to the vehicles. A bus that was not designed to comply with ECE R.66 experienced structural collapse in a rollover crash with one and a half full 360 degree rolls down a 6-meter embankment similar to the one depicted above in Figure 3(b). In contrast, a bus designed to meet ECE R.66 requirements was able to maintain adequate survival space in a rollover crash with two and a quarter full 360 degree rolls down a 9–10 meter embankment similar to the crash depicted in Figure 3(b) above.

In its comments, Advocates references a research project on motorcoach window glazing in which the research used finite element (FE) models to compare the loads on the bus structure in different simulation tests where the bus carried different lateral speeds into its crash with the impact surface.⁷¹ The

simulation scenarios in the research included: (1) No lateral speed with 800 mm drop (replicating ECE R.66), (2) 30 kilometers per hour (km/h) lateral speed with 400 mm drop, and (3) 30 km/h lateral speed with 800 mm drop.⁷²

Advocates refers to a statement by the researchers that the ECE R.66 test is not the most stringent test condition. NHTSA notes that the statement reflected only a preliminary finding of Phase I of the study and was later corrected.⁷³ The preliminary results in Phase I were refined in Phase II of the study. After improving their analysis methodology and conducting the simulation again in Phase II, the researchers conclude that the ECE R.66 test is the more stringent test when compared to tests that incorporated a lateral speed.⁷⁴ As can be seen in the Table 12 data, the ECE R.66 rollover produced higher rollover contact forces than rollover simulations with the ECE R.66 drop height and an initial lateral velocity.

Development for Occupant Impact during a Rollover. (NHTSA–2002–11876).

⁷² See Martec Technical Report # TR–06–16; “Motor Coach Glazing Retention Test Development For Occupant Impact During A Rollover,” (Joint NHTSA and Transport Canada Program; Final Report); Docket No. NHTSA–2002–11876–0015.

⁷³ The authors stated that the models used for the first phase were not detailed and were “only expected to provide rough-order-of-magnitude roof/ground [contact] forces.”

⁷⁴ *Id.*

⁷¹ See Comment from the Advocates for Highway Safety, Docket No. NHTSA–2014–0085–0016, page 5 and 6. The comment references the 2007 NHTSA report, *National Motor Coach Glazing Test*

⁷⁰ *Id.*

TABLE 12—COMPARISON OF ROOF IMPACT FORCES ⁷⁵

	Rollover Scenario					
	No. 1 (ECE R.66)		No. 2 (400 mm)		No 3. (800 mm)	
	Phase I	Current	Phase I	Current	Phase I	Current
Contact Surface	Roof perimeter	Window Posts	Roof Perimeter & Window Posts.	Window posts	Roof Perimeter	Window Posts.
Peak contact Force (N)	4,065,900	2,831,593	4,538,964	2,468,656	3,920,160	2,696,370.
Average Impact Force (N)	1,481,100	1,219,995	2,271,342	891,627	1,960,137	1,149,529.

When a bus traveling at highway speeds tips and begins a multiple-turn roll, the energy in the crash will not be completely transferred to the vehicle structure at the first impact. A significant portion of the energy will go towards sustaining the rolling motion of the bus. Thus, while the vehicle would sustain more impacts during this extended rollover crash, the loads on the superstructure would be lower than the ECE R.66-based test. Further, even if the bus turned only once at highway speed, landed on its side, and slid on the side, the single impact at highway speed would load an entire side of the bus structure, rather than just a corner of the bus superstructure. This flat-faced, wide application of the load dissipates the energy and enables the bus to better withstand the load than the more stringent concentrated load application of FMVSS No. 227. The friction from the sliding of the bus on the surface of the ground also dissipates the kinetic energy of the crash over a longer period—further reducing the load on the vehicle superstructure. In short, FMVSS No. 227 presents a severe real-world application of crash loads on the superstructure, and does so in a controlled, objective manner appropriate for an FMVSS compliance test.

Advocates also discuss a crash variation where the bus may hit an embankment or other “vertical surface” type object. This crash variation may or may not increase the total energy to be dissipated during the crash, but the load concentration may change. However, even with different potential objects loading the structure, we believe that the loads to which the superstructure is subjected might be similar in some respects to the loading to which the superstructure is exposed when tested under FMVSS No. 227. While no embankment or other “vertical surface”-type object is a part of the test, the vehicle superstructure’s loading during the test is akin to the concentrated force that is applied when striking a “vertical surface.” The test involves loading the entirety of the energy in the test onto a

concentrated section of the structure (i.e., the corner of the roof). Thus, we believe that FMVSS No. 227 reflects an aspect of the “vertical surface” and other crash variations about which Advocates is concerned.⁷⁶

For the above reasons, NHTSA concludes that the ECE R.66-based test adopted in this final rule is an effective high-stringency test. The test substantially increases the likelihood that large buses will withstand the crash forces in a real-world rollover crash and provide a survival space to occupants.⁷⁷ FMVSS No. 227 addresses motorcoach crashes that are more than quarter-turn crashes, without having to expose the vehicles to the exact same conditions. Given that all available information indicate that the FMVSS No. 227 test sufficiently replicates a deadly rollover crash, we are adopting the ECE R.66-based test in this final rule.

b. Intrusion Into the Survival Space

The NPRM proposed to prohibit intrusion into the “survival space,” demarcated in the vehicle interior from approximately the rear wall of the bus to 600 mm (24 inches) in front of the front surface of the seat back of the front

⁷⁶ NHTSA also notes that, at this time, the petitioner’s request to incorporate vertical surfaces to mimic a motorcoach accident scenario is impractical to meet. To adopt an objective, repeatable and meaningful test maneuver that incorporates highway speeds and vertical surfaces for the bus to impact, NHTSA should have additional information on what speed is representative, how to trip the bus to initiate a roll, what vertical surface objects are representative, etc. Such information is now unavailable. Further, a test incorporating highway speeds and vertical surfaces is currently not practical as the test conditions are exceedingly difficult to replicate, and pose inordinate safety risks to technicians conducting the test.

⁷⁷ Advocates also points to an NTSB Preliminary Report on a crash of a 1996 Setra Motorcoach operated by AM USA Express, Inc. Comparing the image of that bus (post-crash) in the NTSB Preliminary Report to a bus that NHTSA tested using ECE R.66 in research. Advocates argues that the ECE R.66 test fails to represent real-world crash conditions. Advocates does not present any information regarding the roof structures of these vehicles and whether their structures are similar enough to compare the severity of the crash conditions. There is insufficient information to make any reasonable conclusions comparing the crash severity in these two cases.

row seats, by any part of the vehicle outside the survival space.

The purpose of the proposal is to guard against inadequate survival provided to occupants, especially belted ones, due to collapsing sidewalls, roof structure, or other objects. We intended the requirement to complement our standard requiring seat belts for passengers on the subject buses, to ensure that passengers retained in their seats will have a survival space protecting them from collapsing vehicle structure. Our research found structural intrusions into the survival space in the tested MY 1991, MY 1992, and MY 2000 buses. The NPRM proposed to define the vehicle survival space in a specific manner (see S4 of the proposed standard, 79 FR 46119–46120). The NPRM also proposed use of “survival space templates” in the compliance test.

Overall, commenters concurred with the survival space concept, suggesting small changes to the proposal.

MCI suggested that the survival space requirements should account for variations in vehicle floor heights so that the same height space can be provided in each vehicle segment. MCI requested survival space be defined relative to the forward and rear floor height of each segment of the vehicle.

NHTSA does not believe there is a need to change the survival space definition in response to MCI. The survival space definition already accounts for variations in interior compartment floor height front-to-rear and side-to-side in the vehicle.

However, the agency does believe it should clarify two ambiguities in the survival space definition. First, the “survival space” definition is clarified by defining “occupant compartment” to mean a space within the vehicle interior intended for driver and passenger use, excluding any space occupied by fixed appliances such as bars, kitchenettes, or toilets. Second, the definition of “survival space” is made clearer with regard to a forward-most seat that is not forward-facing. The specification of the centerline used to locate the reference point for the transverse vertical plane was not entirely clear in the NPRM. The “longitudinal” centerline should be

⁷⁵ *Id.*, table from report, page 14.

specified for the most forward point on the most forward seat. Further, the direction that the most forward seat faces will affect the relative positioning of the transverse vertical plane to this seat. This final rule therefore modifies the definition of survival space to specify that the front boundary of the survival space is a transverse vertical plane determined relative to the most forward seat⁷⁸ in the passenger deck when the seat is in its forward-most position and its seat back is in the manufacturer's nominal design riding position. This transverse vertical plane is, (1) for a forward-facing seat, 600 mm in front of the most forward point on the longitudinal centerline of the front surface of the seat back, (2) for a rearward-facing seat, through the most forward point on the longitudinal centerline of the seat back, and (3) for a side-facing seat, through the most forward point on the seat, including the seat back, seat arm rest, and seat cushion.

Intrusion of Items Into the Survival Space

MCI expresses concern that small glass shards falling from a window into the survival space may be a failure per the language of S5.1⁷⁹ of the NPRM.

That was not NHTSA's intent in issuing this rule, but the agency agrees the proposed language could be read to produce such an outcome. NHTSA's intent in maintaining a survival space was to "set a minimum level of structural integrity for these buses, to help prevent dangerous structural intrusions into the occupant survival space."⁸⁰ The intent of the survival space requirement was to ensure "that the roof and sidewalls will be able to withstand the racking forces of a rollover crash."⁸¹ The purpose of retaining the window glazing to its mounting structure was to "ensure that the vehicle's structural integrity will prevent heavy glazing panels from falling into the passenger compartment and becoming ejection portals."⁸² We used "massive" and "heavy" to describe the window glazing panels and discussed a need to "[reduce] risk of injury from falling panels of glazing and occupant ejections." As NHTSA's intent

was not to require protection from "small glass shards" during the bus rollover, this final rule has clarified the requirements to reflect this view, as discussed below.

NHTSA is providing in FMVSS No. 227 that objects of a minute size may intrude into the survival space. As to the size of the objects, the commenters do not provide a suggested definition for "small glass shards." NHTSA thus turned to analyzing the Federal glazing standard to determine how the standard describes acceptably "small" glass shards regarding occupant safety. Glazing material used in motor vehicles must meet the requirements of FMVSS No. 205, "Glazing materials" (49 CFR 571.205). FMVSS No. 205 specifies that "[g]lazing materials for use in motor vehicles must conform to ANSI/SAE Z26.1-1996"⁸³ unless FMVSS No. 205 provides otherwise.

ANSI/SAE Z26.1-1996 allows "small particles" to disengage from the glazing material during some of the laminated glazing⁸⁴ impact tests, though there is no express definition of "small particles" in ANSI/SAE Z26.1-1996. There is a 227 g (0.5 lb) 9.14 m (30 feet) ball drop impact test⁸⁵ in the ANSI standard for laminated glazing. The ball drop test allows "total separation of glass from the reinforcing or strengthening material" that does "not exceed 1935 square millimeters (mm²) (3 square inches (in²)) on either side." (During the rollover testing the agency conducted in support of the FMVSS No. 227 NPRM, laminated glazing panels did shatter, but no discernable amount of the glazing material came free from the interlayer material.)

The ANSI/SAE Z26.1-1996 maximum glazing separation size of 1935 mm² (3 in²) for laminated glazing evaluated using the ANSI ball drop test is helpful in indicating ANSI's determination of the maximum size of glazing that may enter the survival space without causing injury. Glazing pieces 1935 mm² (3 in²) or smaller are not massive or heavy, and the likelihood that they will cause serious blunt trauma injury is significantly lower compared to contact with an entire 84 kg (185 lb) glazing panel in a crash.

However, NHTSA further considered MCI's comment that "a failure of a

single fastener (such as a rivet) that is part of the attachment of the parcel rack assembly could be deemed a failure of the test." The agency decided that small items other than glazing pieces (e.g., a bolt) should be allowed to enter the survival space if small glazing pieces are allowed. Given that the potential for injury caused by pieces entering the survival space is a function of the mass of the item, we decided to limit the items allowed to enter the survival space by the mass of the item.

As to what that mass should be, we again turned to ANSI/SAE Z26.1-1996 and glazing characteristics to start. The ANSI standard permits pieces of laminated glazing of 1935 mm² (3 in²) to separate (break off) in the 227 g (0.5 lb) 9.14 m ball drop impact test. We estimate that laminated glazing has a glass thickness of approximately 2.5 mm for each glass layer, and a glass density⁸⁶ of about 0.00251 g/mm³ (1.445 ounce (oz)/in³). Thus, a piece of laminated glazing of 1935 mm² (3 in²) has a mass of approximately 12 grams (g) (0.43 oz). Factoring in a 3 g (0.11 oz) tolerance, we are prohibiting intrusion into the survival space by any part of the vehicle outside the survival space other than items with a mass of less than 15.0 grams (0.53 oz). Tempered glazing shatters into tiny pebbles that are significantly smaller and lighter than pieces of broken laminated glazing. The shattered pieces of tempered glazing would weigh significantly less than 15.0 grams (0.53 oz).

C. Luggage Racks and Seat Anchorages

As discussed above in this preamble, the NPRM proposed to prohibit any anchorage of an interior overhead luggage rack or compartment or anchorage of a vehicle seat from completely separating from its mounting structure during the movement of the tilting platform or resulting from impact of the bus on the impact surface. After reviewing the comments, NHTSA has decided not to adopt the proposed requirements.

Under the NPRM, those proposed prohibitions would have applied even if the luggage rack does not enter the survival space, or the seat anchorages dislodged within the survival space. NHTSA has decided that the primary purpose of this rulemaking is to establish a roof strength and crush resistance standard that improves the resistance of roofs to deformation and intrusion, *i.e.*, by providing a survival

⁷⁸ This seat could be a passenger seat, the driver's seat, or a temporary (jump) seat.

⁷⁹ 79 FR 46120. The NPRM proposed the following regulatory text (S5.1): No part of the vehicle which is outside the survival space shall intrude into the survival space during the movement of the tilting platform or resulting from impact of the vehicle on the impact surface.

⁸⁰ 79 FR 46092, August 6, 2014.

⁸¹ *Id.*

⁸² *Id.*

⁸³ American National Standard for Safety Glazing Materials for Glazing Motor Vehicles and Motor Vehicle Equipment Operating on Land Highways-Safety Standard (ANSI/SAE Z26.1-1996).

⁸⁴ The requirements for the tempered glazing fracture test in the American National Standards Institute (ANSI) standard require that "no individual fragment free from cracks and obtained within 3 minutes subsequent to test shall weigh more than 4.25 gram (g) (0.15 ounce (oz))."

⁸⁵ ANSI/SAE Z26.1-1996, S5.12

⁸⁶ Glass density value from <https://www.saflex.com/en/AutoReduceVehicleWeight.aspx> I couldn't access this 4/20/20.

space to occupants in rollovers. The purpose is achieved by prohibiting *any* structure, such as overhead luggage racks, from intruding into the survival space. By prohibiting overhead luggage racks from impeding into the survival space in the rollover, overhead luggage racks will have to be better anchored to the bus wall than they had been in the past so that they do not detach and intrude into the survival space in the test. Thus, the proposed luggage rack provision is not needed to provide a survival space, since luggage racks are prohibited from intruding into the survival space. By being securely anchored so that they do not fall into the survival space, luggage racks will be less likely to impede egress in an emergency, or fall and cause head and neck injuries to occupants.

NHTSA has decided against adopting the NPRM's proposal that seat anchorages must not become dislodged during the test. The agency believes the seat anchorage provision is not necessary to achieve a survival space for occupants. NHTSA proposed the requirement for the retention of seat anchorages because of the agency's test of the MY 1991 Prevost LeMirage bus.⁸⁷ In the test, all seats on the opposite side of the impact detached from their sidewall mounting. A seat with a restrained mid-size adult male dummy completely separated from its anchorages and fell across the bus with the restrained dummy attached to the seat. NHTSA believed at the NPRM stage that the failure of the seat anchorages during the rollover test presented a significant safety risk to restrained occupants in bus rollover events and reduced the effectiveness of seat belts.

However, after considering the comments and other information, NHTSA concludes a requirement that the seat anchorages remain completely attached is unnecessary. In NHTSA's test of the MY 2000 MCI bus Model 102-EL3, all of the seats remained attached to their original anchorages. The seats were ballasted with either a 150 lb anthropomorphic ballast or with 150 lb steel weights, which is to say the seats remained attached even while tested under highly demanding conditions. This test of the MY 2000 MCI bus demonstrates that bus seat designs have improved since the MY 1991 and 1992 buses NHTSA tested in its test program.

Second, NHTSA believes the seat anchorage designs are likely to have improved even more since the design of

the MY 2000 bus because of the agency's 2013 final rule requiring lap/shoulder belts on all large buses. The final rule requires the lap/shoulder belts to be integral to the bus seats, and that the belt anchorage, together with the seat anchorage, meet the rigorous strength requirements of FMVSS No. 210, "Seat belt assembly anchorages" 49 CFR 571.210. FMVSS No. 210 requires seat anchorages, attachment hardware, and attachment bolts to withstand loads of 13,345 N (3,000 lb) applied simultaneously to the lap belt portion and the shoulder belt portion of the Type 2 restraint system. Thus, the seat anchorages of new large buses meeting FMVSS No. 210 will be reinforced over and beyond the design of a MY 2000 bus, which reduces the likelihood even further that the seats will detach from the bus structure in a rollover as observed in the tests of the MY 1991 and 1992 buses. Thus, the proposed seat anchorage provision is not necessary to achieve a survival space for occupants.

d. Emergency Exits

The NPRM proposed that emergency exits must remain shut during the rollover test. The agency was concerned about emergency exits opening during a rollover, as NHTSA had observed this to happen in the tests conducted prior to the NPRM. The NPRM also proposed that roof and rear door emergency exits must be operable in the manner required under FMVSS No. 217, "Bus emergency exits and window retention and release," after the test.

Comments Received⁸⁸

EvoBus commented that the proposal that roof exits remain closed is unnecessary, as it did not know that any passenger has been ejected through the roof exit. TEMSA requested that NHTSA move the requirement that side emergency exits remain closed to proposed FMVSS No. 217a. NTSB requested that side emergency exit doors also be required to meet FMVSS No. 227. Advocates suggested the requirement should apply to all side exits.

Agency Response

In response to EvoBus, NHTSA has observed roof exits opening in the FMVSS No. 227 tests conducted in support of the NPRM. Their opening posed an ejection safety risk that this final rule now addresses. Crash data do not identify the portals through which

occupants were ejected, so data records' not indicating ejections through roof exits does not mean such ejections did not or will not occur. The final rule adopts a simple requirement that will reduce an ejection risk from open portals in the chaotic and unpredictable phases of a rollover. The cost of improved emergency latches is minor—\$10 per coach for a total annual new bus fleet cost of \$22,000. Congress, in enacting MAP-21, also wanted NHTSA to address the ejection risk from portals, and an opening in the bus roof caused by an open emergency exit poses an unreasonable risk of ejection of a child's head, limb or body, or those of an adult, in a rollover. NHTSA does not understand why design changes to the roof exits to enable them to meet the FMVSS No. 227 requirements would "cause opening failures," nor did EvoBus explain its statement.

NHTSA does not agree with TEMSA that the requirements should be moved to FMVSS No. 217 or to the proposed FMVSS No. 217a. Both 217 and the proposed 217a do not address the dynamic torsional loads a bus structure transmits to the emergency exits during the rollover test in the manner FMVSS No. 227 does. Potential actuation of emergency exit latches due to inertial loading, assessed by FMVSS No. 227, is not assessed under current FMVSS No. 217 or proposed Standard No. 217a.

NTSB requests that FMVSS No. 227's requirements should also apply to side emergency exit doors.⁸⁹ NHTSA agrees, and had proposed that "emergency exits [should] remain latched to avoid becoming an ejection portal for unrestrained occupants,"⁹⁰ and that "all emergency exits shall not open during the rollover structural integrity test."⁹¹ The final rule adopts the proposal. However, NHTSA has decided not to require side emergency doors and emergency windows be operable after the crash test. The proposed provision that the exits must be operable after the test goes beyond purposes of the rulemaking (to provide a safe survival space and to reduce the risk of ejection through portals).

Further, there are challenges to requiring exits on the non-struck side to open with the bus on its side after the test.⁹² FMVSS No. 217 specifies force

⁸⁹ Under FMVSS No. 217, emergency exit "windows" and emergency exit "doors" are considered "emergency exits," whereas an emergency exit door is a specialized type of emergency exit. *I.e.*, not all emergency exits are emergency exit "doors."

⁹⁰ 79 FR 46109–46110.

⁹¹ 79 FR 46110.

⁹² This issue was discussed in the NPRM (79 FR 46110).

⁸⁷ A summary of the test may be found in the NPRM, *supra*, in section IV.b 79 FR 46100–46102.

⁸⁸ ABA requested an exclusion of entertainer buses from requirements in FMVSS No. 217, S5.2, "Provision of emergency exits." The request is beyond the scope of the rulemaking and is not addressed in this preamble.

requirements needed to open the exit, calculated assuming the bus is upright on its wheels. FMVSS No. 217 only tests the subject buses when they are upright, so there are no gravity considerations. If the bus were tested on its side, the force requirement would have to be calculated to a yet-undetermined level to account for the mass of the window, the effect of gravity, and the fact that an occupant would be pushing on the exit while perched on seats they climbed on. NHTSA does not agree with Advocates that NHTSA should conduct an FMVSS No. 217 test after “righting” the bus on its wheels (buses are tested upright per FMVSS No. 217). The agency is concerned that righting the bus after the severe rollover test of FMVSS No. 227 may not be possible without further damaging the structural integrity of the bus. Further, conducting the test from inside the vehicle as per the FMVSS No. 217 test procedure would expose lab technicians to unreasonable safety risks.

XI. Glazing Issues

a. Side Glazing on the Non-Struck Side of the Bus

The NPRM proposed that each side window glazing on the non-struck side of the vehicle would have to remain attached to its mounting such that there is no opening that will allow the passage of a 102 mm (4 inch) diameter sphere when a force of no more than 22 N is applied.

This final rule does not adopt this provision. The sphere test was proposed to ensure that, after the rollover test, the glazing remain securely attached to its mounting. Because the primary purpose of this rulemaking is to provide a necessary survival space to occupants in rollovers, the purpose is achieved by prohibiting harmful panes of glazing from intruding into the survival space. The proposed requirement that the glazing remain securely attached to its mounting is redundant to the survival space specification and unnecessarily complicates this rulemaking.⁹³

⁹³ Some commenters objecting to the sphere test misunderstood the purpose of the test. The test was not intended to simulate an unbelted passenger's impact onto bus window glazing during a bus rollover. The sphere test was intended simply to measure whether the bus structure retained the glazing panels in the window frame when subjected to a rollover. In the final rule, this would be assessed by the prohibition that no large object enter the survival space. While retention of the glazing in its mounting could reduce occupant ejection, whether the glazing forms an opening through which an ejection could occur in a rollover crash, is the subject of NHTSA's proposed FMVSS No. 217a and will be addressed in the context of that rulemaking. 81 FR 27904, May 6, 2016, *supra*.

b. Type of Glazing

EPGAA, Greyhound and Advocates requested that the agency require advanced glazing material in bus windows, while Prevost, Van Hool, and EvoBus suggest that tempered glass should be permitted. Prevost expresses that “there is a small possibility that some glazing could shatter when submitted to the proposed testing.” Prevost and EvoBus request an exclusion of tempered glazing from the rule, or that shattered glazing not be considered a failure of the FMVSS No. 227 requirements.

Agency Response

The agency is not distinguishing among glazing types in FMVSS No. 227 or providing exclusions of tempered glazing. The standard is generally performance-oriented and technology neutral, requiring window glazing and surrounding window frame structures on the non-struck sides of the bus to be manufactured so as not to unsafely intrude into the survival space in the rollover test. As discussed above, this final rule accommodates intrusion of small pebbles of tempered glass into the survival space. This final rule makes allowances for minute objects weighing less than 15.0 grams to enter the survival space, in recognition that it may be difficult, and unnecessary, to keep more miniscule pieces of glazing and other items from entering the survival space in the FMVSS No. 227 rollover event.

The requirement in FMVSS No. 227 preventing bus components from intruding into the survival space is critical to rollover safety if the subject buses employ advanced glazing that mitigate the risk of occupant ejection in rollovers. NHTSA's research⁹⁴ found that advanced glazing, such as laminated glazing, could pop out of its mounting due to torsional deformation of the structure around the window. FMVSS No. 227's survival space requirement would improve the structural integrity around window frames and prevent glazing from popping out or otherwise detaching from its window mount in a rollover.

c. Moon Roofs

NTSB requested NHTSA consider including “moon roofs” in the glazing retention requirements of FMVSS No. 227. We agree with NTSB that “moon roofs” should be subject to the requirements of FMVSS No. 227, as

⁹⁴ Martec Limited, “Motorcoach Glazing Retention Test Development For Occupant Impact During a Rollover,” August 2006; Docket No. NHTSA–2002–11876–0015.

there is a risk of passenger ejection through glass roofs during a bus rollover. Rather than use the term “moon roofs” however, hereinafter we use the term “roof panel/windows” since the latter term is more descriptive and inclusive of the components we seek to address.

Ejections through the roof occur in real-world crashes. From 2000–2009, two-thirds of the rollover fatalities in the subject buses were ejected occupants.⁹⁵ Two of the crashes (Turrell, Arkansas in 2004 and Mexican Hat, Utah in 2008) discussed in the NPRM involved roof separation from the bus. Almost all the passengers in those two crashes were ejected due to the loss of the bus roofs. In such crash events, unrestrained passengers can still be ejected if a bus that meets the survival space requirements fails to keep roof panels/windows closed or intact. We believe that manufacturers can use the same countermeasures to retain roof panels/windows to the glazing frames that they use to keep side window glazing attached to the side window frames.

MAP–21⁹⁶ defines a portal as “any opening on the front, side, rear, or roof of a motorcoach that could, in the event of a crash involving the motorcoach, permit the partial or complete ejection of any occupant from the motorcoach, including a young child.” Roof panels/windows are portals per the MAP–21 definition. Any bus opening containing glazing material is a portal that can become an opening through which bus occupants may be partially or completely ejected if the glazing detaches from its mounting. The final rule's including roof panels/windows in FMVSS No. 227 accords with MAP–21. We will evaluate roof panels/windows like we do side windows. *I.e.*, no portion of a roof panel/window may enter the survival space, except for objects weighing less than 15.0 grams, and they must remain closed.

d. Struck-Side Window Evaluations

Several commenters (Advocates, Greyhound, NTSB, the families, and Ms. Stoops) request that the agency evaluate windows on the struck side as well as the non-struck side of the bus.

Under FMVSS No. 227, the agency can roll either side of the bus. Thus, manufacturers must ensure that vehicles can resist the torsional loads imparted into the structure on either side of the bus. To the extent the commenters suggest the sphere test should be conducted on the struck-side windows

⁹⁵ 79 FR 46098; August 6, 2014.

⁹⁶ See Sec. 32072, *supra*.

when the bus is resting on the ground, as discussed above the agency is not adopting the sphere test, or any test involving lab technicians entering the rolled vehicle to assess compliance with a requirement.

XII. Test Procedure Issues

a. Ballasting the Vehicle

To simulate a real-world rollover incorporating foreseeable conditions that are challenging to the vehicle, NHTSA proposed to subject the vehicle to the forces resulting from the mass of restrained occupants. To achieve this, the NPRM proposed (in S6.2.5 of the regulatory text) that a mass up to 68 kg (150 lb) (ballast) be secured in each designated seating position (DSP) equipped with a seat belt.⁹⁷ The ballast would represent the mass of an “average” occupant, and is the mass NHTSA uses in determining a vehicle’s GVWR per 49 CFR part 567, “Certification.” NHTSA stated that ballasting is important because it increases the weight and center of gravity of the vehicle, which better simulates the forces on the vehicle structure in a rollover when the seats are occupied by belted passengers. Also, when occupants are belted into the vehicle, their mass imparts crash forces to the seat anchorages during a crash, which NHTSA sought to replicate in the test (79 FR 46105–46107).

The agency indicated in the NPRM that it did not believe the method of ballasting or type of ballast used were of importance, as those factors will not significantly alter the forces imposed on the vehicle structure or the seat anchorages during compliance testing, so long as the ballast is 68 kg (150 lb) at each DSP. NHTSA noted in the NPRM that the NPRM differed from ECE R.66 on this issue of ballasting. ECE R.66 specifies the option of two different methods of securing occupant ballast to the passenger seats.⁹⁸ It

⁹⁷ All DSPs in the buses are required to have seat belts per our November 25, 2013 MAP–21 final rule amending FMVSS No. 208 (78 FR 70416).

⁹⁸ As discussed in the NPRM (79 FR 46107), we tested both types of ballasts, anthropomorphic (“water dummies”) ballasts and fixed steel ballasts, to determine the feasibility of each and the differences between the two. We found that the method of ballasting and type of ballast used were not important, as these factors did not significantly alter the forces upon the vehicle structure or the seat anchorages during the test, so long as the ballast is 68 kg (150 lb). Four commercially available “water dummies,” each filled with 68 kg (150 lb) of sand, were installed in one full row of seats (four seating positions) and were secured with ratchet straps that were configured to simulate Type 2 seat belts. Steel ballasts, 68 kg (150 lb) per seating position, were installed in a second full row of seats (four seats). In this row, steel plates were placed on top of each seat cushion and were secured with

reduces the load to 34 kg (75 lb) when a fixed ballast is used (79 FR 46106). Further, it specifies a different ballasting method.⁹⁹

Comments Received

Several bus manufacturers commented on the proposal, all requesting that we adopt the ballasting approach of ECE R.66 (*i.e.*, the anthropomorphic ballast at 68 kg (150 lb) and the fixed steel plate ballast at 34 kg (75 lb)).¹⁰⁰ All the commenters essentially argue that passengers in a bus, restrained by the seat belts, will not transfer their entire load onto the seat anchorages and bus structure in the same way as fixed ballasts. Therefore, commenters argue, when using the fixed steel plate ballasts, the ballast weight should be 34 kg (75 lb) (*i.e.*, 50 percent of the weight for anthropomorphic ballasts).

In support of their view that a 50 percent weight is appropriate for fixed ballasts, the commenters argue that ECE R.66 considers a 75-lb weight for fixed steel ballasts equivalent to the 150-lb anthropomorphic ballast secured with the seat belt. Van Hool cites an ECE Ad Hoc Expert Group document that puts the load transferred by belted occupants to the vehicle structure as between 0 and 100 percent of the standard passenger mass of 68 kg (150 lb).¹⁰¹

bolts that passed through the cushion and attached to a bar which clamped onto the seat frame. The overall center of gravity of the bus, and consequently, the energy absorbed in the test, was only slightly higher (less than 3 percent) when the water dummies were used compared to when the fixed weights were used. The differences in forces and moments generated at the anchorages due to the ballasts were also small.

⁹⁹ In addition to specifying a different weight for fixed steel plate ballasts, ECE R.66 requires the ballasts be fixed to the seat such that its center of gravity aligns with that of the anthropomorphic ballast (*i.e.*, approximately 100 mm forward and 100 mm above the seating reference point). However, NHTSA simply proposed to fix the steel ballasts to the seat because in the agency’s research NHTSA found it difficult to position and fix the rigid weights per the ECE specification. We investigated whether affixing the rigid weights as specified by ECE R.66 is necessary and stated in the NPRM that it was not. The different center of gravity heights between the anthropomorphic ballasts and the fixed weight ballasts did not appear to affect the overall performance of the vehicle in the rollover test. 79 FR 46107.

¹⁰⁰ Greyhound Lines, Inc., an operator, suggested that NHTSA should ballast the overhead luggage racks during rollover testing. Ballasting of luggage rack and the lower luggage compartment of a motorcoach was not proposed in the August 6, 2014 NPRM and therefore the public was not provided a full opportunity to comment on this issue. ECE R.66 does not require ballasting of the luggage rack, and NHTSA does not see a safety need for a requirement to ballast the luggage racks.

¹⁰¹ See Report about the Ad-Hoc Expert Group (AHEG) meeting dealing with the development of Regulation 66 (Frankfurt, 22–23, November, 2001), available at <https://www.unece.org/fileadmin/DAM/>

Prevost and Daimler both cite an ECE analysis finding that 50 percent of the restrained occupant’s weight transfers to the bus structure during a crash.¹⁰²

Agency Response

NHTSA is adopting the provision to use the 68 kg (150 lb) ballast in NHTSA’s compliance test. NHTSA does not concur that a 75-lb (50 percent lighter weight) fixed ballast would simulate a similar amount of force on the seat anchorages and bus structure as a 150-lb occupant.

Prevost’s and Daimler’s comments reflect the state of knowledge in 2001, a time early in the development of ECE R.66. According to their cited analysis, there were no experimental data available at the time to evaluate the percentage of mass that should be included in the test. At that time, it was then theorized that 50 percent of the occupant weight was an appropriate estimate for the weight that a restrained occupant would transfer to the bus structure. However, subsequent published studies have found that the 50 percent value grossly underestimates the amount of force imparted by restrained bus occupants.

As discussed in the NPRM (79 FR 46106), an Australian study that utilized bus section testing and computer simulations¹⁰³ estimated that 93 percent of a lap/shoulder belt-restrained occupant mass, 75 percent of a lap belt-restrained occupant mass, and 18 percent of an unrestrained occupant mass are effectively coupled to the vehicle structure during a rollover. Further, a European Commission sponsored study in 2003¹⁰⁴ found that the percentage of occupant mass coupled to the vehicle structure during a rollover is 90 percent for lap/shoulder belted occupants and 70 percent for lap belted occupants. Based on these research findings, NHTSA proposed in the NPRM to use the full weight of 150 lb (68 kg) at all DSPs.

Since the NPRM, NHTSA has learned about additional studies that corroborate the Australian and ECE findings. An

trans/doc/2002/wp29grsg/TRANS-WP29-GRSG-82-inf02.doc (last accessed February 8, 2017).

¹⁰² Study about the Incidence of the Use of Safety Belts with regard to Regulation 66 of Geneva, presented by Spain at the 81th Working Party on General Safety Provisions (GRSG), October, 2001, https://www.unece.org/fileadmin/DAM/trans/main/wp29/wp29wgs/wp29grsg/grsginf/81/grsg81_inf09.doc (last accessed February 8, 2017).

¹⁰³ Anderson, J., *et al.*, “Influence of Passengers During Coach Rollover,” Cranfield Impact Centre Ltd., 18th International Technical Conference on the Enhanced Safety of Vehicles, Nagoya, Japan, Paper No. 216, 2003.

¹⁰⁴ Enhanced Coach and Bus Occupant Safety (ECBOS), Project No. 1999–RD.11130, European Commission, 5th Framework, August 2003.

Italian study¹⁰⁵ reports that seat deformation is influenced by an occupant's weight during rollover testing. Reports co-authored by TEMSA¹⁰⁶¹⁰⁷ conclude that 90 percent of the passengers' mass should be added to the rollover vehicle mass. Thus, the data cited by Prevost and Daimler appear to be outdated. Available studies now uniformly agree that more than 90 percent of the occupant mass is coupled with the bus during a rollover crash. Accordingly, we disagree with ballasting only 50 percent of the 150-lb occupant load.

For the above reasons, we are adopting the proposed language from the NPRM on ballasting. Using lower weight ballast for the fixed ballast, as suggested by some commenters, would not adequately simulate the loading conditions of the average restrained occupant.¹⁰⁸

b. Vehicle Fluids

NHTSA specified that all fluids in the vehicle, including fuel, would be at maximum capacity during the test. For environmental and test personnel safety, NHTSA proposed to use substitute fluids to conduct the test if the weight of the original fluid was maintained.

Comments Received

Van Hool commented that NHTSA should not include vehicle fluid specifications and should permit manufacturers to replace parts of the bus representative masses. The commenter believed that manufacturers should be able to decide on these conditions and determine them for their bus if "the basic features and behaviour [sic] of the superstructure are not influenced by it." Van Hool recommends that the agency use the ECE R.66 definition of cg to determine whether the manufacturer's selected

¹⁰⁵ Belingardi, G., Martella, P., and Peroni, L., "Coach Passenger Injury Risk During Rollover: Influence of the Seat and the Restraint System," 19th International Technical Conference on the Enhanced Safety of Vehicles, Washington DC, Paper No. 05-0439, 2005.

¹⁰⁶ Guler, M., Atahan, A., and Bayram, B., "Effectiveness of Seat Belt Usage on the Rollover Crashworthiness of an Intercity Coach"; 21st International Technical Conference on the Enhanced Safety of Vehicles, Stuttgart, Germany, Paper No. 09-0205, 2009.

¹⁰⁷ Elitok, K., Guler, M., Bertan Bayram, B., and Stelzmann, U., "An Investigation on the Roll-Over Crashworthiness of an Intercity Coach, Influence of Seat Structure and Passenger Weight," 9th International LS-DYNA Users Conference, 2006.

¹⁰⁸ NHTSA asked for comment on whether, when fixed ballasts are used, it is necessary to specify a specific center of gravity for the fixed steel plate ballasts. 79 FR 46107. No comments were received on this issue. For the reasons in the NPRM, NHTSA believes it is sufficient for the steel ballasts to be placed on top of the seat cushion.

vehicle conditions are appropriate for testing.

Agency Response

We have changed the regulatory text so that vehicle fluid fill levels are now specified as a percentage range of the maximum capacity rather than only as maximum capacity. FMVSS No. 227 specifies that the agency will test the bus with all fluids (or replacement fluids) at 90 to 95 percent of the maximum level for each of the fluids.

In specific response to Van Hool, NHTSA does not believe the requested change is necessary. Van Hool requested that NHTSA use manufacturer-defined test conditions for items such as the vehicle fluid levels and representative masses for expensive vehicle parts, if the manufacturer-specified conditions maintain a specified cg. As NHTSA explained in the NPRM, in the U.S., manufacturers self-certify their products' compliance with the FMVSSs. The test conditions specified in an FMVSS specify the conditions under which NHTSA will assess compliance. The purpose of specifying these conditions is to give manufacturers notice of how NHTSA will test, not to prescribe the testing methods that manufacturers must use to certify compliance.

To illustrate, FMVSS No. 227 specifies that the agency will test the bus with all fluids (or replacement fluids) at 90 to 95 percent of the maximum level for each of the fluids. The standard does not require manufacturers to conduct the test under the same conditions. Manufacturers may use different testing methods to certify compliance with the FMVSSs. They must reasonably conclude that their vehicles will pass the FMVSS test when tested by NHTSA as specified in the FMVSS. It is not incumbent on NHTSA to specify in the FMVSSs all the possible testing methods a manufacturer might use as a basis for its certification.

c. Additional Tools for Survival Space Evaluation During Testing

Van Hool suggested that additional evaluation tools be permitted as supplemental or alternatives to the proposed survival space template, to simplify testing. It stated that high-speed photography, video, deformable templates, electrical contact sensors, and other suitable evaluation and techniques should be permitted as part of the standard.

After considering the comment, NHTSA has decided to change some of the language in the regulatory text of FMVSS No. 227 to provide more flexibility in the tools the agency will

use to measure compliance. As stated in the NPRM, we intended that "[o]ther tools could also be used to help determine whether there was intrusion into the survival space, such as deformable templates, high speed video, photography, or a combination of means. NHTSA could use templates and/or other means of determining whether intrusion occurred."¹⁰⁹ However, describing the use of survival space templates in detail in the regulatory text of FMVSS No. 227 implies the opposite, and makes unclear NHTSA's flexibility to use other compliance tools that are not described in the regulatory text. We believe it would be more efficient for the agency to move the specifications on the detailed use of templates or other methods to a test procedure document that NHTSA's Office of Vehicle Safety Compliance publishes.

XIII. Other Issues

a. ECE R.66 Alternative Compliance Methods

The rollover test in this final rule is based on the complete vehicle test from ECE R.66. NHTSA is not adopting ECE R.66's four alternative options for complying with ECE R.66 requirements.¹¹⁰ The following options are considered by ECE R.66 to be equivalent approval tests: (1) A rollover structural integrity test of body sections representative of the vehicle, (2) quasi-static loading tests of body sections, (3) quasi-static calculations based on testing of components, and (4) computer simulation (finite element analysis) of a complete vehicle.¹¹¹

Comments Received

Bus manufacturers already producing vehicles subject to ECE R.66 (Van Hool, TEMSA, Prevost, EvoBus) asked NHTSA to adopt the alternatives of ECE R.66. TEMSA believed that computer

¹⁰⁹ 79 FR 46109.

¹¹⁰ There are significant differences in the way a manufacturer demonstrates compliance with safety regulations in European Union and in the United States. In Europe, European governments use "type approval," which means that they approve particular designs as complying with their safety standards. In the U.S., NHTSA issues performance standards, to which manufacturers self-certify that their vehicles or equipment comply. NHTSA does not pre-approve vehicles or equipment before sale. Under the Vehicle Safety Act, the FMVSSs must be objective, repeatable, and meet certain other statutory criteria. NHTSA enforces the FMVSSs by obtaining new vehicles and equipment for sale and testing them to the requirements in the FMVSSs according to the procedures specified in the standards.

¹¹¹ Further information regarding the alternative certification methods of ECE R.66 is available at: Motorcoach Roof Crush/Rollover Testing Discussion Paper, March 2009, Docket No. NHTSA-2007-28793-0019.

simulation would be feasible if NHTSA “defines the performance requirements, assumptions, calculations and validation method in the regulation, [and] all manufacturers make the same assumptions and perform the test with same simulation and analysis methods.” Prevost believed that ECE R.66 alternatives may be used to prove certification of designs that are “evolutions of what already exists.” EvoBus believed not allowing numerical simulation imposes a burden because “it would be necessary to provide a vehicle with exactly the same specifications as the one which gave raise to questions.”

Agency Response

This final rule adopts the complete vehicle test of ECE R.66 into FMVSS No. 227. By doing so, NHTSA is specifying the test procedure NHTSA will use to assess a vehicle’s compliance with FMVSS No. 227. The standard will not provide for NHTSA’s use of Alternatives 1 through 4 to determine compliance. However, this does not mean that manufacturers must use the complete vehicle test to certify their vehicles. To the contrary, the Safety Act requires manufacturers to ensure their vehicle meet all applicable FMVSSs, and that they certify the compliance of their vehicle with applicable FMVSS. The Safety Act specifies that manufacturers may not certify if in exercising reasonable care the manufacturer has reason to know the certificate is false or misleading. This means a manufacturer may use the alternative compliance methods of ECE R.66 to certify its vehicles if it can do so in exercising reasonable care. While manufacturers must ensure that their vehicles will meet the requirements of FMVSS No. 227 when NHTSA tests the vehicles in accordance with the test procedures specified in the standard, they do not have to conduct the test described in FMVSS No. 227 to certify that compliance.

NHTSA considered ECE R.66’s alternative compliance methods but determined that they would not be practical for the agency’s compliance program. (See explanation in the NPRM, 79 FR 46111–46112.) The agency has considered the comments but has not changed its mind.

Alternatives 1 and 2 involve testing body sections. To obtain a body section, NHTSA could procure it from the manufacturer, but that raises questions about how representative the sample would be of buses in actual production. Some manufacturers might make a more conscientious effort to produce the specimen, and so the specimen might

not be representative of a typical mass-produced bus. NHTSA could section a bus itself, but that would be impractical and a waste of resources.

Alternatives 1 and 2 require that the body-sections be representative of the entire vehicle. Determining the representativeness of a body-section would require input and analysis from the manufacturer, and even with that, determining what is “representative” could be subjective and difficult for NHTSA to verify. (*E.g.*, is the center of gravity of the body section representative of the whole vehicle?) Importantly, it might make more sense if the representative sample were representative of the worst-case (weakest) section, to make sure all body sections of the bus are capable of passing the test. The alternatives do not make it clear that NHTSA could test the weakest section, and thus do not make clear that the entire vehicle would have to meet the standard.

Testing an entire vehicle rather than body sections is preferable to NHTSA because it better ensures all body sections will be able to conform to FMVSS No. 227, including representative as well as worse-case (weakest) sections of the bus. Testing an entire bus to the complete vehicle test is the most objective, scientific way to assure the entire bus structure is satisfactory and the glazing panels are retained.

Regarding Alternatives 3 and 4, under the Safety Act, NHTSA is directed to issue performance standards,¹¹² the compliance with which must be measured objectively.¹¹³ A concern with assessing compliance using calculations, extrapolations, and computer simulations is that entities may differ in opinion as to whether a manufacturer’s calculations and computer simulations were appropriate or correctly made for demonstrating compliance in a particular instance. A manufacturer may have the knowledge of the materials and joint structure for their vehicles to be able to accurately model them, while an external entity may not be able to easily reproduce those results.

The variability of assumptions in such models makes this method less preferable for use by NHTSA in

¹¹² In 49 U.S.C. 30102, the Vehicle Safety Act defines “motor vehicle safety” as the “performance” of motor vehicles or motor vehicle equipment in a way such as to avoid creating an unreasonable risk of accident to the general public. The same Act defines “motor vehicle safety standards” as minimum standards for motor vehicle or motor vehicle equipment “performance.”

¹¹³ In 49 U.S.C. 30111(a), the Vehicle Safety Act requires that Federal motor vehicle safety standards be stated in objective terms.

evaluating compliance with an FMVSS. For example, for Alternative 3, we would need to identify the location of the plastic zones and plastic hinges as well as estimate their load-deformation curves. For Alternative 4, mathematical models that simulate accurately the actual rollover crash of the vehicle are required.

Further, there is a concern that basing compliance on calculations and computer simulations may not account for differences that may occur between the analytical model and the vehicle as *manufactured*. Because an actual vehicle is not involved in the assessment of compliance using Alternatives 3 and 4, these alternatives might not account for variation or flaws in material properties, or quality control deficiencies in the manufacturing build processes. A design that looks acceptable “on paper” or in theory might not turn out so as assessed by testing an actual vehicle. To the extent possible, NHTSA prefers to test actually-manufactured vehicles, to assess not only the design of the vehicle, but the real-world production of the vehicle.

In short, deficiencies in vehicle performance due to poor quality control of manufacturing processes, sub-standard quality of supplied materials or errors in the engineering analysis underlying the vehicle design can be better discovered when an actual vehicle is tested than under a compliance system using Alternatives 3 and 4.

For these reasons, this final rule is based on the complete vehicle test of ECE R.66 to determine compliance. NHTSA is incorporating ECE R.66’s compliance framework in a manner that meets the requirements of MAP–21 and the requirements and considerations of NHTSA’s Safety Act. The agency emphasizes that FMVSS No. 227 does not preclude manufacturers from using the alternative compliance methods of ECE R.66 to certify their vehicles. As explained in the NPRM,¹¹⁴ although an engineering analysis model would not be appropriate as the agency’s method of assessing the compliance of vehicles with a Federal motor vehicle safety standard manufacturers are not required to use NHTSA’s test as the basis for their certification. While the agency’s test defined in the proposed regulatory test would be an objective test capable of determining which vehicles meet the minimum requirements, manufacturers can use other methods (such as the alternative compliance options in ECE

¹¹⁴ 79 FR 46117; August 6, 2014.

R.66) in certifying the compliance of their own vehicles.

Manufacturers using ECE R.66's alternatives are responsible for ensuring that the vehicles will meet the requirements of FMVSS No. 227 when tested by NHTSA per the agency's procedures. However, manufacturers certifying compliance of their own vehicles have much more detailed information regarding their own vehicles and production methods than NHTSA and should be capable of using other methods to certify their vehicles. If manufacturers are confident that the data obtained by using the test methods described in ECE R.66's Alternatives 1 through 4 assure conformance with the standard just as the complete vehicle test does, nothing precludes them from using those alternatives to certify their vehicles to FMVSS No. 227 with confidence.

b. Regulatory Alternatives

In deciding on the approach adopted by this final rule, NHTSA examined the following alternatives.

1. FMVSS No. 216

NHTSA considered the requirements of FMVSS No. 216, "Roof crush resistance." FMVSS No. 216 applies to vehicles with a GVWR of 4,536 kg (10,000 lb) or less (light vehicles), and specifies a test that applies localized static loads to the upper front corners of a vehicle's roof and windshield area. The large buses covered under this final rule are larger/heavier than light vehicles and are more likely to roll along a longitudinal vehicle axis than yaw and pitch. Thus, in an actual rollover involving one of these vehicles, the entire length of the vehicle is loaded as in the ECE R.66 test. NHTSA believes the ECE R.66 test is more representative of a real-world rollover of a large bus than the FMVSS No. 216 test since the ECE R.66 test imparts loads along the full length of the vehicle.

In addition, the ECE R.66 test is a dynamic test in which "survival space" performance requirements are specially designed for the large bus interior. There are also additional safety issues specific to the vehicles covered by this rule (opening of emergency exits, detachment of windows from their mountings) that can be evaluated in the dynamic event. Since two-thirds of rollover fatalities are due to ejections, addressing these additional safety issues is vital to addressing the safety problem in rollovers. Therefore, the agency believes that the ECE R.66 test addresses more of the safety needs of a large bus rollover crash than the FMVSS No. 216 test.

2. FMVSS No. 220

FMVSS No. 220 is a school bus roof crush standard that places a uniformly distributed vertical force pushing directly downward on the top of the bus with a platen that is 914 mm (36 inches) wide and that is 305 mm (12 inches) shorter than the length of the bus roof. The standard specifies that when a uniformly distributed load equal to 1.5 times the unloaded vehicle weight is applied to the roof of the vehicle's body structure through a force application plate, the downward vertical movement at any point on the application plate shall not exceed 130 mm (5.125 inches) and the emergency exits must be operable during and after the test.

The agency included FMVSS No. 220 in its research into rollover structural integrity for large buses and, in the NPRM, tentatively decided the ECE R.66 test was preferable to the FMVSS No. 220 for motorcoaches for several reasons. First, the agency determined that an ECE R.66 based test is more suitable for the vehicles covered by FMVSS No. 227 than an FMVSS No. 220-based test because a significant portion of fatalities in the subject buses result from occupant ejections. Unlike school buses, the subject motorcoach and other large buses operate intercity routes and typically travel at higher speeds than school buses transporting children to a local educational facility. Further, many of the motorcoaches and subject intercity buses are designed with a higher center of gravity than school buses and have larger windows. These characteristics can lead to a higher incidence of occupant ejections during rollovers involving the non-school buses. The agency believed dynamic rollover test in ECE R.66 affords the agency the opportunity to better evaluate ejection-related factors such as the emergency exits and side window glazing retention during a rollover crash.

After considering the comments, NHTSA makes the following decisions. As previously discussed, the agency is permitting manufacturers of school bus derivative buses to certify compliance with FMVSS No. 220 as an alternative to certifying to the ECE R.66 test in FMVSS No. 227. FMVSS No. 220 has been proven to adequately ensure roof crush protection in vehicles designed to meet the FMVSSs applying to school buses, so allowing school bus derivative buses to meet FMVSS No. 220 avoids redundancy in the FMVSS. NHTSA is not permitting FMVSS No. 220 as an alternative to FMVSS No. 227 for buses other than school bus derivative buses. The dynamic test in FMVSS No. 227 is

a more representative test of real-world rollovers for motorcoaches and buses other than school buses and addresses safety needs arising in rollovers of those vehicles that FMVSS No. 220 does not address.

c. Additional MAP-21 Considerations

In addition to the MAP-21 provisions discussed previously in this document, MAP-21 also directs NHTSA to consider the best available science, potential impacts on seating capacity, and potential impacts on the size/weight of motorcoaches.¹¹⁵ Further, MAP-21 directs the agency to consider combining the various motorcoach rulemakings contemplated by MAP-21 and to avoid duplicative benefits, costs, and countermeasures.¹¹⁶

NHTSA considered the best available science in developing this final rule. The agency developed this rule based on FMVSS No. 220 and ECE R.66 test studies NHTSA conducted on large bus rollover structural integrity (*see* section IV of the NPRM), and after considering advanced glazing countermeasures (*see* May 6, 2016 (81 FR 27904) NPRM, *supra*, and "Motor Coach Glazing Retention Test Development For Occupant Impact During A Rollover," Martec Technical Report # TR-06-16, Rev 4, August 2006¹¹⁷). NHTSA considered FMVSS No. 216 and ECE R.66 alternative compliance methods (*see* sections VI of the NPRM).

Coach USA provided the only response to the NPRM request for comment on the impact of added vehicle weight to seating capacity. It requested NHTSA to consider that further increases to motorcoach weight could make it difficult for all operators to carry a full passenger load while still complying with applicable vehicle and axle weight limits. NHTSA does not believe this final rule will adversely impact seating capacity. Large bus buyers expect maximum seating capacity with adequate luggage capacity for a given floor space or vehicle length. Estimates for structural weight added to a bus to meet this final rule are based on usage of steel.¹¹⁸ NHTSA is aware that other methods of reinforcing the structure (such as the use of high strength steel sections, rigid polyurethane foam filling to reinforce and stabilize thin walled hollow sections, and optimized designs that

¹¹⁵ *See* MAP-21 section 32703(e)(1).

¹¹⁶ *See id.* at section 32706(b)-(c).

¹¹⁷ Docket No. NHTSA-2002-11876-0015.

¹¹⁸ Final Regulatory Evaluation Large Bus Structural Integrity FMVSS No. 227; NHTSA Office of Regulatory Analysis and Evaluation, National Center for Statistics and Analysis. Available in the docket for this rule.

redistribute the impact loads and enhance the energy absorption capability) may enable a large bus to withstand greater crash forces without increasing as much weight.¹¹⁹

Through this final rule and our accompanying Final Regulatory Evaluation (FRE), the agency has considered the potential impacts of this rule on the size and weight of motorcoaches and other large buses affected by this rule.¹²⁰ As described further in the next section (and in the FRE), we have considered potential weight increases to motorcoaches as a cost of this final rule due to increased fuel consumption. In the accompanying FRE, we have quantified and accounted for this increased fuel consumption cost in our cost-benefit analysis of the rule. After considering all costs, including the potential weight increase, the agency concludes that the requirements in this final rule will be cost-beneficial.

NHTSA has designed this rule to complement the agency's 2013 final rule on FMVSS No. 208 requiring seat belts for passenger seating positions. The seat belt rule will result in increasing numbers of passengers buckling up on large buses. As they do so, more and more will be retained within the passenger compartment in crashes. NHTSA has designed it so that FMVSS No. 227 and FMVSS No. 208 work together to provide a survival space to the passengers retained within the passenger compartment due to the seat belts. NHTSA has also designed this final rule bearing in mind NHTSA's May 6, 2016 NPRM,¹²¹ issued pursuant to section 32703(b)(2) of MAP-21, that proposes to adopt an advanced glazing standard for large buses (OTRBs and non-OTRBs with a GVWR greater than 11,793 kilograms (26,000 pounds)). The reinforcements to the superstructure and bus body to meet FMVSS No. 227's structural integrity requirements will increase the likelihood that anti-ejection advanced glazing installed consistent with section 32703(b)(2) will be retained in a rollover crash.

Finally, NHTSA is avoiding duplicating benefits, costs, and countermeasures in the motorcoach rulemakings of MAP-21. As described

above, the agency believes that the requirements of FMVSS No. 227 work together with the passenger seat belt requirements of FMVSS No. 208 and complements an advanced glazing standard. As described in the accompanying FRE, the agency has estimated the benefits and costs of this final rule while considering the effect of seat belts on the subject buses and the application of the ESC rule.

XIV. Lead Time

The agency proposed a compliance date of 3 years after publication of the final rule for FMVSS No. 227. MAP-21 (in section 32703(e)) directs that the rulemaking shall apply to all motorcoaches manufactured more than 3 years after the date on which the regulation is published as a final rule.

Comments Received

IC Bus agreed with the proposed 3-year lead time. Van Hool stated "that for the requirements for the strength of superstructure according to the Series of Amendment 01 of UN Regulation No. 66 . . . a transition period of 144 months was granted."

Agency Response

This final rule adopts the 3-year compliance date. To enable manufacturers to certify to the new requirements as early as possible, optional early compliance with the standard is permitted. The 3-year date for motorcoaches is required by MAP-21. If Van Hool was requesting a 144-month lead time, NHTSA declines the request as contrary to MAP-21. Further, the commenter provided no information to support or further explain their interest in or need for a 144-month (12-year) lead time for the effective date of FMVSS No. 227. Van Hool and others currently manufacture buses for sale to European countries including Italy, France, Germany, Poland, and the Netherlands.¹²² Each of these countries is listed under the 1958 Agreement as countries granting approval to buses meeting the requirements of ECE R.66. Since Van Hool already designs buses for ECE R.66 requirements, NHTSA believes that the commenter has a good foundation for manufacturing buses that meet the structural requirements of FMVSS No. 227.

NHTSA concludes that three years of lead time will be sufficient for bus manufacturers generally to make the necessary changes. The lead time for motorcoaches is mandated by MAP-21,

but it is also reasonable. Van Hool and other manufacturers of buses that already meet ECE R.66 may have to improve the type of latches used on emergency exits, and improve the mounting of side windows, but three years will be ample time to complete the design, testing, and changes in production necessary to certify compliance to the FMVSS No. 227 requirements.

For manufacturers whose buses do not already meet ECE R.66, NHTSA believes that manufacturers will need to make structural design changes to their large bus models either by changing the strength of the sidewall and glazing frame material or the material's physical dimensions (*i.e.*, thickness or width). Per the results of our test program conducted in support of this rulemaking, newer buses may need stronger side pillars to meet the glazing retention requirements, and redesigned mechanisms on roof exits and side window exits to ensure that they do not release during the impact. We believe that these changes can be done within three years. Further, we note that under 49 CFR 571.8(b), manufacturers of buses other than motorcoaches built in two or more stages and alterers are provided an additional year of lead time for manufacturer certification and compliance.

XV. Retrofitting Used Buses

The agency stated in the NPRM that, based on the agency's tests of older buses, major structural changes to the vehicle's entire sidewall and roof structure would be needed for some existing buses to meet the proposed rollover structural integrity requirements. NHTSA believed that the structural changes are likely to be cost-prohibitive, making retrofitting for rollover structural integrity impractical. NHTSA requested comments on the feasibility, benefits, and costs of any potential requirement to retrofit existing buses to meet FMVSS No. 227.

Comments Received

Almost half of the respondents to the NPRM commented on the retrofit issue and all opposed retrofitting. IC Bus, Daimler Trucks, Van Hool, ABA, Greyhound, Coach USA, Prevost, and Advocates raised concerns about retrofit. They believed that the work involved in retrofitting a bus to meet FMVSS No. 227, even just the glazing aspects of the standard, would entail impracticable and unreasonable reworking of the bus structure. The complications of retrofit are exacerbated, they stated, by having to deal with the condition of existing

¹¹⁹ See Lilley, K. and Mani, A., "Roof-Crush Strength Improvement Using Rigid Polyurethane Foam," SAE Technical Paper 960435, 1996. Available at: <https://subscriptions.sae.org/content/960435/>, see also Liang, C. and Le, G. Optimization of bus rollover strength by consideration of the energy absorption ability. International Journal of Automotive Technology. Vol. 11.(2) 173-185. Available at: <https://www.springerlink.com/content/tk824863k66w0228/export-citation/>.

¹²⁰ "Motorcoach" in this paragraph has the meaning given in MAP-21 (OTRBs).

¹²¹ 81 FR 27904, *supra*.

¹²² Information from review of Van Hool website press release information. Obtained February 24, 2017 (<https://www.vanhool.be/ENG/bedrijfsinfo/historiek/historiek2009-20.html>).

structures, the lack of original design information, and possible need for Federal oversight and approval of each bus's structural rework.

Agency Response

NHTSA is not specifying a retrofit requirement. The agency did not receive or discover any new information that would alter the previous determination that retrofitting of existing buses would be impracticable and unreasonable. The agency continues to expect the structural changes needed for retrofitting to be substantial, and to involve significant costs beyond those estimated in our regulatory analysis for new buses. The cost impacts would likely have a substantial adverse impact on a significant number of small entities (e.g., owner-operators of buses used for transport), without a commensurate safety benefit. Therefore, NHTSA reaffirms the earlier decision not to require retrofit of used buses to meet FMVSS No. 227.

XVI. Overview of Costs and Benefits

Based on the FARS data over the 15-year period between 2004 and 2018, there were a total of 56 fatal rollover crashes involving the bus types covered by this final rule, resulting in 189 occupant fatalities. Beyond the benefits attributable to the rules on seat belts and ESC for these vehicles, NHTSA estimates this final rule will save approximately 3 lives annually (undiscounted) if 15 percent of occupants use seat belts, and approximately 2 lives annually (undiscounted) if 90 percent of occupants use seat belts.¹²³ NHTSA estimates this final rule will reduce the number of seriously injured occupants by approximately 4 annually. These estimated benefits are distinct from the passenger protections attributable to the seat belt and ESC requirements for buses covered by this final rule and are conservative estimates. As explained later in this section, these estimates do not count possible benefits to belted

occupants who were saved from injury or fatality because of the survival space provided by FMVSS No. 227.

While belted occupants will benefit from a survival space, unbelted occupants will benefit as well. The belted occupant will mostly benefit from reduced intrusion of structures and objects into the survival space. The unbelted occupants will benefit from a reduced risk of occupant ejection. Given these differences in how occupants will benefit from the rule, we have estimated benefits for each group separately.

Also, the benefits estimates will vary by seat belt use. Available research regarding seat belt use suggests that it can be highly variable. NHTSA has estimated the lower end of seat belt use at 15 percent and the upper end of seat belt use at 90 percent. The agency assumes that, initially, belt use will be closer to the lower end (15 percent) because passengers are not yet accustomed to seat belts on the buses. Many large buses in use do not have seat belts, and passengers have not been educated about the benefits of buckling up in a large bus.

NHTSA estimates that at 3 percent and 7 percent discount rates, 1.87 to 2.45 equivalent lives are saved annually if 15 percent of occupants use seat belts and 1.46 to 1.92 equivalent lives are saved annually if 90 percent of occupants use seat belts (see Table 13 below).

The agency estimates that, assuming steel is used to strengthen the vehicle structure to comply with the requirements in this final rule, material costs for each vehicle will range from \$325 to \$591 and cost between \$0.71 million and \$1.30 million to equip the entire new large bus fleet annually (see Table 14 below). NHTSA further estimates that, if steel is used to comply, the total weight increase will range from 181 to 356 kg (399 to 784 lb) and cost an additional \$1,862 to \$4,790 in fuel per vehicle over the lifetime of the vehicle. The total fuel cost for the new fleet is estimated to be \$4.10 million to

\$10.54 million. The total costs will be approximately \$4.81 million to \$11.84 million annually. The cost per equivalent life saved is estimated to be between \$2.48 million and \$6.38 million (see Table 15 below) and net economic benefit is estimated to be between \$8.25 million and \$23.31 million in 2020 dollars.

The available information shows this final rule is cost beneficial. The above estimates for the cost per equivalent life of this rule vary due to uncertainties regarding seat belt use rates and the incremental increase in weight that is necessary to meet FMVSS No. 227. For seat belt use, NHTSA believes that the projected net impact on the economy will be closer to the estimates for the 15 percent belt use rates than the 90 percent belt use rate, as explained above. A large portion of the costs of this structural integrity rule is dependent on this incremental increase in weight. NHTSA does not have more specific information regarding the likely weight increase to these vehicles.

The agency believes that the cost effectiveness of this rule is not very sensitive to changes in belt usage rates because belted passengers will still realize safety benefits because of this rule. Many serious injuries that occur in large bus crashes can occur despite a passenger's use of a safety belt. For example, while belted passengers may not be ejected, they can still be struck by the collapsing side wall of the bus. Therefore, even though increasing seat belt usage rates may mean that more passenger ejections (and fatalities) will be prevented by seat belts (consequently reducing the number of prevented ejections attributable to FMVSS No. 227), the final rule will still be effective in preventing serious injuries to belted passengers. Thus, we expect that the monetized value of the benefits of this rule is not very sensitive to fluctuations in seat belt use—even though the type of benefit will change.¹²⁴

TABLE 13—ESTIMATED ANNUAL BENEFITS
[Equivalent lives saved]

	15% belt use	90% belt use
3% Discount	2.45	1.92
7% Discount	1.87	1.46

¹²³ The FRE prepared in support of this final rule assumes that the seat belt use rate on large buses will be between 15 percent and the percent use in passenger vehicles, which was 90 percent in 2009. To maintain consistency with the seat belt rule, we have used the same low belt usage rate estimate of 15 percent from that rule, and the same source of

information to establish the high belt usage rate estimate (See 2009 National Occupant Protection Use Survey. More information at: <https://www-nrd.nhtsa.dot.gov/pubs/811100.pdf>).

¹²⁴ For further information, see the FRE prepared in support of this final rule. The FRE discusses

issues relating to the potential costs, benefits and other impacts of this regulatory action. The FRE is available in the docket for this final rule and may be obtained by downloading it or by contacting Docket Management at the address or telephone number provided at the beginning of this document.

TABLE 14—ESTIMATED ANNUAL COSTS
[2020 Dollars]

Potential Costs:	
Material Costs Per Vehicle	\$325 to \$591.
Material Costs, Total New Fleet	\$0.71 million to \$1.30 million.
Fuel Costs per Vehicle @ 3%	\$2,441 to \$4,790.
Fuel Costs per Vehicle @ 7%	\$1,862 to \$3,654.
Fuel Costs, Total New Fleet	\$4.10 million to \$10.54 million.
Total Annual Cost	\$4.81 million to \$11.84 million.

TABLE 15—COST PER EQUIVALENT LIFE SAVED IN MILLIONS (M) OF 2020 DOLLARS

	15% belt use 3% discount	15% belt use 7% discount	90% belt use 3% discount	90% belt use 7% discount
Cost (New Vehicle + Fuel)	6.08–11.84	4.81–9.34	6.08–11.84	4.81–9.34
Equivalent Lives Saved	2.45	1.87	1.92	1.46
Cost per Equivalent Life Saved	2.48–4.83	2.57–4.99	3.17–6.17	3.28–6.38

The cost of reinforcing the roof strength and structural integrity of these vehicles to meet the requirements in this final rule are predominantly dependent upon the material and weight increases necessary to reinforce the superstructure. NHTSA estimates that the countermeasures may include stronger roof and side walls, shock resistant latches for emergency exits, and improved window mounting. As mentioned above, these material costs for each vehicle are estimated to be between \$325 and \$591. However, while the agency assumes in these estimates that steel is applied to reinforce the vehicle structure, the agency is aware that other methods of reinforcing the structure (such as the use of high strength steel sections, rigid polyurethane foam filling to reinforce and stabilize thin-walled, hollow sections, and optimized designs that redistribute the impact loads and enhance the energy absorption capability) may enable a vehicle to withstand greater crash forces without adding as much weight.¹²⁵ Therefore, while our analysis has assumed the use of steel, the agency is aware that there may be other countermeasures that weigh less—which could result in lower fuel costs—than we have currently estimated, over the lifetime of the vehicle.

¹²⁵ See Lilley, K. and Mani, A., “Roof-Crush Strength Improvement Using Rigid Polyurethane Foam,” SAE Technical Paper 960435, 1996. Available at: <https://subscriptions.sae.org/content/960435/>; see also Liang, C. and Le, G. Optimization of bus rollover strength by consideration of the energy absorption ability. International Journal of Automotive Technology. Vol. 11.(2) 173–185. Available at: <https://www.springerlink.com/content/tk824863k66w0228/export-citation/>.

The agency also notes that, in addition to the quantifiable benefits mentioned above, there are other benefits arising from this final rule. Our economic analysis of this rule is only able to calculate the benefits that can be realized above and beyond the benefits attributable to previously-published final rules, in particular, the November 25, 2013 (78 FR 70416) seat belt final rule. In other words, we are only able to estimate the benefits to passengers whose serious and fatal injuries were not prevented by seat belts. When an occupant who would have been seriously or fatally injured in a bus crash is estimated as saved from such injury by a countermeasure previously made effective for that occupant (e.g., a seat belt), NHTSA no longer estimates additional benefits for that particular passenger.

However, we believe that some people who were saved by the seat belt could still benefit from this rule, as the poor structural integrity of a bus could contribute toward a fatality or an injury for this saved occupant. It is important to note that while the agency could estimate benefits to belted passengers who still were seriously injured or killed notwithstanding the seat belts, because of our practices we do not estimate what additional benefits could be realized by passengers who were already considered saved from serious and fatal injury due to the seat belts. As the agency is unaware of any available information that would enable the agency to quantify this latter benefit, the agency’s economic analysis of this rule only estimates the benefits to occupants

who were not saved by the seat belts.^{126 127}

XVII. Rulemaking Analyses and Notices

Executive Order (E.O.) 12866, E.O. 13563, and DOT Rulemaking Procedures

NHTSA has considered the impact of this final rule under Executive Orders 12866 and 13563, and DOT administrative rulemaking orders and procedures. This final rule is not considered significant and was not reviewed by the Office of Management and Budget under E.O. 12866.

This final rule increases roof strength and structural integrity for certain large bus types by establishing requirements for maintaining survival space and emergency exit operability during and after a rollover structural integrity test. This final rule specifies a test procedure that tilts the vehicle on a platform until the vehicle becomes unstable and rolls over onto a level concrete impact surface.

¹²⁶ Thus, we believe our estimate of benefits is conservative, undercounting possible benefits to occupant who were saved from fatal ejection by seat belts but still seriously injured by collapsing structure or unrestrained heavy vehicle components intruding into the survival space.

¹²⁷ This final rule will also theoretically result in additional benefits by functioning to support NHTSA’s proposed rule on FMVSS No. 217a, *supra*, to mitigate ejection risks through installation of advanced glazing. This final rule will provide for the structural foundation, or anchor, to retain advanced glazing to the vehicle when that advanced glazing is installed per the proposed FMVSS No. 217a. While this final rule on FMVSS No. 227 could result in associated benefits regarding FMVSS No. 217a, we have not quantified them for this rulemaking proceeding.

NHTSA has prepared a FRE for this final rule.¹²⁸ Beyond the benefits attributable to rules on seat belts for this same group of vehicles and ESC, NHTSA estimates that this final rule will save approximately 3.12 equivalent lives annually if seat belt usage among occupants is 15 percent, and approximately 2.45 equivalent lives annually if seat belt usage is 90 percent. The total cost of making the necessary structural changes, and of lifetime fuel costs, will be approximately \$4.81 million to \$11.84 million annually (for the entire new fleet). The net cost per equivalent life saved is estimated to be between \$2.48 million and \$6.38 million. The benefits, costs, and other impacts of this rulemaking are discussed at length in the FRE.

Executive Order 13609: Promoting International Regulatory Cooperation

The policy statement in section 1 of Executive Order 13609 provides, in part: The regulatory approaches taken by foreign governments may differ from those taken by U.S. regulatory agencies to address similar issues. In some cases, the differences between the regulatory approaches of U.S. agencies and those of their foreign counterparts might not be necessary and might impair the ability of American businesses to export and compete internationally. In meeting shared challenges involving health, safety, labor, security, environmental, and other issues, international regulatory cooperation can identify approaches that are at least as protective as those that are or would be adopted in the absence of such cooperation. International regulatory cooperation can also reduce, eliminate, or prevent unnecessary differences in regulatory requirements.

As mentioned in this preamble, the agency has considered regulatory approaches taken by foreign governments (namely, the European Union in ECE R.66) and decided to base FMVSS No. 227 on ECE R.66. In addition to the goal of reducing unnecessary differences in regulatory requirements between the U.S. and its trading partners, the agency has found the ECE R.66 test to be the most suitable test available for ensuring a minimum reasonable level of protection for passengers traveling in buses that are associated with the highest crash risk. While NHTSA has determined that it is not able to adopt the entirety of ECE R.66 and has adopted emergency exits

latching requirements which are not in ECR R.66, the agency has explained its rationale for its decisions in the relevant sections of this document.

Regulatory Flexibility Act

Pursuant to the Regulatory Flexibility Act (5 U.S.C. 601 *et seq.*, as amended by the Small Business Regulatory Enforcement Fairness Act (SBREFA) of 1996), whenever an agency is required to publish a notice of rulemaking for any proposed or final rule, it must prepare and make available for public comment a regulatory flexibility analysis that describes the effect of the rule on small entities (*i.e.*, small businesses, small organizations, and small governmental jurisdictions). The Small Business Administration's regulations at 13 CFR part 121 define a small business, in part, as a business entity "which operates primarily within the United States." (13 CFR 121.105(a)). No regulatory flexibility analysis is required if the head of an agency certifies that the rule will not have a significant economic impact on a substantial number of small entities. The SBREFA amended the Regulatory Flexibility Act to require Federal agencies to provide a statement of the factual basis for certifying that a rule will not have a significant economic impact on a substantial number of small entities.

NHTSA has considered the effects of this rulemaking action under the Regulatory Flexibility Act. Per 13 CFR 121.201, the Small Business Administration's size standards regulations used to define small business concerns, manufacturers of the vehicles covered by this rule fall under North American Industry Classification System (NAICS) No. 336111, *Automobile Manufacturing*, which has a size standard of 1,000 employees or fewer. NHTSA estimates that there are 26 manufacturers of these types of vehicles in the United States (including manufacturers of motorcoaches, cutaway buses, second-stage motorcoaches, and other types of large buses covered by this rule). Using the size standard of 1,000 employees or fewer, we estimate that approximately 10 of these 26 manufacturers are considered small businesses.

I certify that this final rule will not have a significant economic impact on small entities. First, the agency estimates that the incremental costs to each vehicle would be \$325 to \$591 per unit to meet the rule. This incremental cost would not constitute a significant impact given that the average cost of the vehicles covered by this rule ranges from \$200,000 to \$400,000. Further,

these incremental costs, which are very small compared to the overall cost of the vehicle, can ultimately be passed on to the purchaser and user.

In addition, the agency believes that certifying compliance with the rule will not have a significant impact on the small manufacturers. These entities have various options available that they may use to certify compliance with the standard.

This final rule adopts ECE R.66's compliance framework in a manner that meets the requirements of MAP-21 and the requirements and considerations of NHTSA's Safety Act. The standard will not provide for NHTSA's use of Alternatives 1 through 4 to determine compliance. However, this does not mean that manufacturers must use the complete vehicle test to certify their vehicles. To the contrary, the Safety Act requires manufacturers to ensure their vehicle meet all applicable FMVSSs, and that they certify the compliance of their vehicle with applicable FMVSS. The Safety Act specifies that manufacturers may not certify if in exercising reasonable care the manufacturer has reason to know the certificate is false or misleading. This means a manufacturer may use the alternative compliance methods of ECE R.66 to certify its vehicles if it can do so in exercising reasonable care. While manufacturers must ensure that their vehicles will meet the requirements of FMVSS No. 227 when NHTSA tests the vehicles in accordance with the test procedures specified in the standard, they do not have to conduct the test described in FMVSS No. 227 to certify that compliance.¹²⁹

One option is to certify compliance using modeling or engineering analyses (such as a plastic hinge analysis of portal frames of the vehicle). ECE R.66 itself accounts for and accommodates this compliance option, and this approach has been used for years by European manufacturers in meeting ECE R.66. An engineering analysis model is less preferable to the dynamic test procedure specified in this rule as the agency's method of assessing the

¹²⁹ Under the Vehicle Safety Act, a manufacturer can avoid civil penalties associated with a noncompliance if it showed that it exercised due care in certifying its vehicles. A showing of due care can be based on engineering analyses, computer simulations, and the like, and NHTSA will assess the due care upon which the certification is made by evaluating, among other factors, the size of the manufacturer and its resources. Even small manufacturers, however, are responsible for having a reasonable idea as to whether their vehicles comply with the standard. They are responsible for proclaiming that their vehicles will comply should NHTSA test their vehicle. The alternatives discussed in this section provide those bases for certification.

¹²⁸ Final Regulatory Evaluation Large Bus Structural Integrity FMVSS No. 227; NHTSA Office of Regulatory Analysis and Evaluation, National Center for Statistics and Analysis. Available in the docket for this rule.

compliance of vehicles with an FMVSS, since the agency may not know enough about the assumptions to use in the model or whether the model in fact represents the subject vehicle as manufactured. However, unlike NHTSA, manufacturers have access to much more information regarding their own vehicles and can analyze information of sufficient detail and breadth about vehicle design, material characteristics and production processes to form a basis for their certification. They can use their own methods for certifying compliance of their vehicles, such as engineering analyses to certify their vehicles. If the basis for their certification is made using reasonable care, they will have met the requirement of section 30115 to certify the compliance of their vehicles. If they used reasonable care in certifying and manufacturing the vehicles, the likelihood that the vehicles will pass the FMVSS No. 227 compliance test when tested by NHTSA according to the standard is very high.

The manufacturer could test body sections of the vehicle, as contemplated by ECE R.66, Alternatives 1 and 2. The manufacturer could “section” the vehicle or otherwise obtain a body section representative of the vehicle and of the weakest section of the vehicle. It could base its certification on these tests, without testing a full vehicle. As discussed above, they know their vehicles best, and can test the section most at risk of not meeting FMVSS No. 227 to make sure the vehicle would meet the standard when tested by NHTSA in the complete vehicle test. This process will allow small manufacturers to test parts of the vehicle for compliance, and use their engineering expertise to calculate that the bus will meet the standard when NHTSA tests it in accordance with the procedure specified in FMVSS No. 227.

In the event small manufacturers elect to conduct a test of a full vehicle, there are various methods available to reduce the costs of the test. One such method is by testing a vehicle which is not completely new. As the requirements in this final rule pertain to structural integrity, we believe that a manufacturer could test the relevant body design on an old bus chassis or other underlying structure, and could sufficiently assess and certify the compliance of the vehicle’s structural integrity to FMVSS No. 227. Similarly, the agency believes that more costly parts of the vehicle (such as the engine and other portions of the powertrain) could be replaced in a complete vehicle test of a bus with ballast equal to the weight of the absent components. The small manufacturer

could base its certification on such testing, which do not involve a destructive test of an actual vehicle.

NHTSA notes that the product cycle of large buses subject to FMVSS No. 227 is much longer than other vehicle types. With a longer product cycle, the agency believes that the costs of certification for manufacturers would be further reduced as the costs of conducting compliance testing and the relevant analyses could be spread over a significantly longer period.

This rule may affect operators of the buses—some of which may be small businesses—but only indirectly as purchasers of these vehicles. As mentioned above, NHTSA anticipates that the impact on these businesses will not be significant because (assuming that additional steel is used for compliance) the expected price increase of the vehicles used by these businesses is small (\$325 to \$591 for each vehicle (vehicles valued between \$200,000 and \$400,000)). NHTSA anticipates that fuel costs for these businesses will increase between \$1,862 and \$4,790 (in 2020 dollars) per vehicle over its lifetime. These expected increases in costs are small in comparison to the cost of each of these vehicles. Given that these costs will equally affect all operators, the small operators will be able to pass these costs onto their consumers. This final rule does not require retrofitting of vehicles on the road.

Executive Order 13132 (Federalism)

NHTSA has examined this final rule pursuant to Executive Order 13132 (64 FR 43255; Aug. 10, 1999) and has determined that no additional consultation with States, local governments, or their representatives is mandated beyond the rulemaking process. The agency has concluded that the rule does not have sufficient federalism implications to warrant consultation with State and local officials or the preparation of a federalism summary impact statement. The rule does not have “substantial direct effects on the States, on the relationship between the national government and the States, or on the distribution of power and responsibilities among the various levels of government.”

NHTSA rules can have preemptive effect in two ways. First, the National Traffic and Motor Vehicle Safety Act contains an express preemption provision that when a motor vehicle safety standard is in effect under this chapter, a State or a political subdivision of a State may prescribe or continue in effect a standard applicable to the same aspect of performance of a

motor vehicle or motor vehicle equipment only if the standard is identical to the standard prescribed under the chapter. 49 U.S.C. 30103(b)(1). It is this statutory command by Congress that preempts any non-identical State legislative and administrative law address the same aspect of performance.

The express preemption provision described above is subject to a savings clause under which “[c]ompliance with a motor vehicle safety standard prescribed under this chapter does not exempt a person from liability at common law.” 49 U.S.C. 30103(e). Pursuant to this provision, State common law tort causes of action against motor vehicle manufacturers that might otherwise be preempted by the express preemption provision are generally preserved. However, the Supreme Court has recognized the possibility, in some instances, of implied preemption of State common law tort causes of action by virtue of NHTSA’s rules—even if not expressly preempted.

This second way that NHTSA rules can preempt is dependent upon the existence of an actual conflict between an FMVSS and the higher standard that would effectively be imposed on motor vehicle manufacturers if someone obtained a State common law tort judgment against the manufacturer— notwithstanding the manufacturer’s compliance with the NHTSA standard. Because most NHTSA standards established by an FMVSS are minimum standards, a State common law tort cause of action that seeks to impose a higher standard on motor vehicle manufacturers will generally not be preempted. However, if and when such a conflict does exist—for example, when the standard at issue is both a minimum and a maximum standard—the State common law tort cause of action is impliedly preempted. See *Geier v. American Honda Motor Co.*, 529 U.S. 861 (2000).

Pursuant to Executive Order 13132, NHTSA has considered whether this rule could or should preempt State common law causes of action. The agency’s ability to announce its conclusion regarding the preemptive effect of one of its rules reduces the likelihood that preemption will be an issue in any subsequent tort litigation.

To this end, the agency has examined the nature (*e.g.*, the language and structure of the regulatory text) and objectives of this final rule and does not foresee any potential State requirements that might conflict with it. NHTSA does not intend that this final rule preempt state tort law that would effectively

impose a higher standard on motor vehicle manufacturers than that established by this rule. Establishment of a higher standard by means of State tort law would not conflict with the standard issued by this final rule. Without any conflict, there could not be any implied preemption of a State common law tort cause of action.

National Environmental Policy Act

NHTSA has analyzed this final rule for the purposes of the National Environmental Policy Act. The agency has determined that implementation of this action will not have any significant impact on the quality of the human environment.

Paperwork Reduction Act

Under the procedures established by the Paperwork Reduction Act of 1995, a person is not required to respond to a collection of information by a Federal agency unless the collection displays a valid Office of Management and Budget (OMB) control number. This rulemaking would not establish any new information collection requirements.

National Technology Transfer and Advancement Act

Under the National Technology Transfer and Advancement Act of 1995 (NTTAA) (Pub. L. 104–113), “all Federal agencies and departments shall use technical standards that are developed or adopted by voluntary consensus standards bodies, using such technical standards as a means to carry out policy objectives or activities determined by the agencies and departments.” Voluntary consensus standards are technical standards (*e.g.*, materials specifications, test methods, sampling procedures, and business practices) that are developed or adopted by voluntary consensus standards bodies, such as SAE International. The NTTAA directs this agency to provide Congress, through OMB, explanations when the agency decides not to use available and applicable voluntary consensus standards.

While the agency is not aware of any voluntary standards that exist regarding rollover structural integrity for the large buses covered by this final rule, the agency has examined the applicable European Union standard (ECE R.66). As discussed extensively above, we have adopted an ECE R.66-based test, in part, to avoid requiring manufacturers to meet fundamentally different rollover requirements than those required in the European Union. The areas of this final rule that differ from ECE R.66, and the reasons in support, are extensively

discussed in the earlier sections of this preamble.

Executive Order 12988

With respect to the review of the promulgation of a new regulation, section 3(b) of Executive Order 12988, “Civil Justice Reform” (61 FR 4729, February 7, 1996) requires that Executive agencies make every reasonable effort to ensure that the regulation: (1) Clearly specifies the preemptive effect; (2) clearly specifies the effect on existing Federal law or regulation; (3) provides a clear legal standard for affected conduct, while promoting simplification and burden reduction; (4) clearly specifies the retroactive effect, if any; (5) adequately defines key terms; and (6) addresses other important issues affecting clarity and general draftsmanship under any guidelines issued by the Attorney General. This document is consistent with that requirement.

Pursuant to this order, NHTSA notes as follows. The issue of preemption is discussed above in connection with E.O. 13132. NHTSA notes further that there is no requirement that individuals submit a petition for reconsideration or pursue other administrative proceeding before they may file suit in court.

Unfunded Mandates Reform Act

The Unfunded Mandates Reform Act of 1995 requires agencies to prepare a written assessment of the costs, benefits and other effects of proposed or final rules that include a Federal mandate likely to result in the expenditure by State, local or tribal governments, in the aggregate, or by the private sector, of more than \$158 million annually (adjusted for inflation to 2020 dollars with base year of 1995). This final rule will not result in expenditures by State, local or tribal governments, in the aggregate, or by the private sector in excess of \$158 million annually.

Plain Language

Executive Order 12866 and E.O. 13563 require each agency to write all rules in plain language. Application of the principles of plain language includes consideration of the following questions:

- Have we organized the material to suit the public’s needs?
- Are the requirements in the rule clearly stated?
- Does the rule contain technical language or jargon that isn’t clear?
- Would a different format (grouping and order of sections, use of headings, paragraphing) make the rule easier to understand?

- Would more (but shorter) sections be better?
- Could we improve clarity by adding tables, lists, or diagrams?
- What else could we do to make the rule easier to understand?

If you have any responses to these questions, please inform us.

Regulation Identifier Number (RIN)

The Department of Transportation assigns a regulation identifier number (RIN) to each regulatory action listed in the Unified Agenda of Federal Regulations. The Regulatory Information Service Center publishes the Unified Agenda in April and October of each year. You may use the RIN contained in the heading at the beginning of this document to find this action in the Unified Agenda.

Privacy Act

Anyone is able to search the electronic form of all comments received into any of our dockets by the name of the individual submitting the comment (or signing the comment, if submitted on behalf of an association, business, labor union, etc.). You may review DOT’s complete Privacy Act Statement in the **Federal Register** published on April 11, 2000 (65 FR 19477–78).

List of Subjects in 49 CFR Part 571

Imports, Motor vehicles, Motor vehicle safety.

In consideration of the foregoing, NHTSA amends 49 CFR part 571 as follows:

PART 571—FEDERAL MOTOR VEHICLE SAFETY STANDARDS

- 1. The authority citation for part 571 continues to read as follows:

Authority: 49 U.S.C. 322, 30111, 30115, 30117, and 30166; delegation of authority at 49 CFR 1.95.

Subpart B—Federal Motor Vehicle Safety Standards

- 2. Section 571.227 is added to read as follows:

§ 571.227 Standard No. 227; Bus rollover structural integrity.

S1. *Scope.* This standard establishes performance requirements for bus rollover structural integrity.

S2. *Purpose.* The purpose of this standard is to reduce death and injuries resulting from the structural collapse of the bus body structure in rollover crashes and from partial and complete ejections through emergency exits opening in such crashes.

S3. *Application.*

(a) Subject to S3(b), this standard applies to:

(1) Over-the-road buses; and
(2) Buses that are not over-the-road buses, and that have a gross vehicle weight rating (GVWR) greater than 11,793 kilograms (26,000 pounds).

(b) This standard does not apply to:

(1) School buses, school bus derivative buses, transit buses, and prison buses; and
(2) Buses with 7 or fewer designated seating positions rearward of the driver's seating position that are forward-facing or can convert to forward-facing without the use of tools.

S4. Definitions.

Occupant compartment means a space within the vehicle interior intended for driver and passenger use, excluding any space occupied by fixed appliances such as bars, kitchenettes, or toilets.

Over-the-road bus means a bus characterized by an elevated passenger deck located over a baggage compartment.

Prison bus means a bus manufactured for the purpose of transporting persons subject to involuntary restraint or confinement and has design features consistent with that purpose.

School bus is defined in § 571.3.

School bus derivative bus means a bus that meets Federal motor vehicle safety standards for school buses regarding emergency exits (§ 571.217), rollover protection (§ 571.220), bus body joint strength (§ 571.221), and fuel system integrity (§ 571.301).

Stop-request system means a vehicle-integrated system for passenger to use to signal to a vehicle operator that they are requesting a stop.

Survival space means all points within a three-dimensional space in the occupant compartment as defined within the following volume:

(1) The front boundary of the survival space is a transverse vertical plane forward of the most forward seat (whether passenger, or driver seat) when the seat back is in the manufacturer's nominal design riding position. This transverse vertical plane is:

(i) For a forward-facing seat, 600 millimeters (mm) in front of the forward most point on the longitudinal centerline of the front surface of the seat back when the seat is in its forward most position;

(ii) For a rearward-facing seat, through the most forward point (relative to the vehicle) on the longitudinal centerline of the seat back when the seat is in its forward most position with respect to the vehicle;

(iii) For a side-facing seat, through the most forward point (relative to the

vehicle) on the seat, including the seat back, seat arm rest, and seat cushion.

(2) The rear boundary of the survival space is the inside surface of the rear wall of the occupant compartment of the vehicle.

(3) The outer boundary of the survival space at any transverse cross section between, or at the front and rear boundaries, is defined on each side of the vehicle by the occupant compartment floor and the following three line segments (see Figure 1 of this section, provided for illustration purposes only):

(i) Segment 1 extends vertically from the floor to an end point that is 500 mm above the floor and 150 mm inboard of the side wall.

(ii) Segment 2 starts at the end point of Segment 1. The end point of Segment 2 is 750 mm vertically above and 250 mm horizontally inboard of the end point of Segment 1.

(iii) Segment 3 is a horizontal line that starts at the end point of Segment 2 and ends at the vertical longitudinal center plane of the vehicle.

Transit bus means a bus that is equipped with a stop-request system sold for public transportation provided by, or on behalf of, a State or local government and that is not an over-the-road bus.

S5. *Requirements.* When tested under the conditions in S6 and the test procedures specified in S7, each bus shall meet the requirements in S5.1 and S5.2.

S5.1 *Survival space intrusion.* No part of the vehicle that is outside the survival space shall intrude into the survival space during the movement of the tilting platform or resulting from impact of the vehicle on the impact surface, except as provided below in this paragraph.

(a) Items separated from the vehicle and with a mass less than 15.0 grams that enter the survival space will not be considered for this evaluation of survival space intrusion.

(b) Portions of a bus over which there is not a permanent roof, such as the upper level of an open-top double-decker bus, will not be considered for this evaluation.

S5.2 *Opening of Emergency exits.* Emergency exits shall not open during the movement of the tilting platform or resulting from impact of the vehicle on the impact surface.

S6. Test conditions.

S6.1 Tilting platform.

S6.1.1 The tilting platform has a top surface that rests horizontally at its initial position and is of sufficient size to fully contact the bottom of the vehicle's tires, as shown in Figure 2 of

this section (figure provided for illustration purposes only).

S6.1.2 The top surface of the tilting platform, at its initial position, is 800 ± 20 millimeters (mm) above the impact surface specified in S6.1.6, as shown in Figures 1 and 2 of this section (figures provided for illustration purposes only).

S6.1.3 The axis of rotation of the tilting platform is a maximum of a 100 mm horizontal distance from the edge of the impact surface closest to the platform and a maximum of 100 mm below the horizontal plane at the top surface of the tilting platform as shown in Figure 3 of this section (figure provided for illustration purposes only).

S6.1.4 The tilting platform is equipped with rigid wheel supports on the top surface as illustrated in Figure 3 of this section (figure provided for illustration purposes only). At each vehicle axle, the wheel closest to the platform's axis of rotation is supported. The rigid wheel supports are positioned to make contact with the outboard tire sidewall of the supported wheels with the vehicle positioned as specified in S6.3.1 to prevent sliding of the vehicle during the test. Each rigid wheel support has the following dimensions:

(a) The height above the top surface of the tilting platform is no greater than two-thirds of the vertical height of the adjacent tire's sidewall.

(b) The width is a minimum of 19 mm.

(c) The length is a minimum of 500 mm.

(d) The top inboard edge has a radius of 10 mm.

S6.1.5 While raising the platform, the tilting platform roll angle, measured at the outside of each wheel farthest from the pivot point, does not differ by more than one degree.

S6.1.6 The impact surface is horizontal, uniform, dry, and smooth concrete. The impact surface covers an area that is large enough to ensure that the vehicle does not strike beyond the impact surface edges.

S6.2 Vehicle preparation.

S6.2.1 The vehicle's tires are inflated to the manufacturer's recommended tire pressure.

S6.2.2 Test equipment may be attached securely to the bus structure such that the equipment does not break away from the bus structure from the time the tilting platform begins movement to after the vehicle comes to rest on the impact surface.

S6.2.3 Fixed seats may be removed or adjustable seats repositioned for the installation of test equipment in the survival space. Ballast of any weight up to the weight of the removed seat and 68 kg per designated seating position

may be secured to the bus floor. The ballasts are not placed farther forward than the forward most point of the vehicle seat immediately in front of the removed seat, and the ballasts are not placed farther rearward than the rear most point of the vehicle seat immediately behind the removed seat.

S6.2.4 The fuel tank is filled to any level from 90 to 95 percent of capacity. All other vehicle fluids are filled to any level from 90 to 95 percent of capacity. Fluids may be substituted if the weight of the original fluid is maintained.

S6.2.5 *Ballasting*. The vehicle is loaded to any weight up to and including the GVWR. Up to 68 kilograms (150 pounds) of ballast is installed at all designated seating positions that are equipped with occupant restraints. The ballast is

placed on the top of each seat cushion and attached securely to the seat frame such that it does not break away from the seat from the time the tilting platform begins movement to after the vehicle comes to rest on the impact surface.

S7 Rollover structural integrity test procedure. Each vehicle shall meet the requirements of S5 when prepared as specified in S6.2 and tested in accordance with the procedures set forth in paragraphs (a) through (f) of this S7.

(a) Position the vehicle on the tilting platform as illustrated in the examples of Figures 2 and 3 of this section with its longitudinal centerline parallel to the tilt platform's axis of rotation, the right or left side facing the impact surface at NHTSA's option, and with the outboard

tire sidewall at the widest axle within 100 mm of the axis of rotation. (Figures provided for illustration purposes only.)

(b) Apply the vehicle parking brakes.

(c) Attach a rigid wheel support to the tilting platform at each axle of the vehicle so that it contacts the outboard tire sidewall of the wheel closest to the impact surface.

(d) Block the suspension system of the vehicle to be within ± 25 mm of the normal riding attitude as loaded in S6.2.5.

(e) Vehicle windows, doors, and emergency exits are fully closed and latched but not locked.

(f) Tilt the vehicle at a rate not to exceed 5 degrees/second until it starts to rollover on its own.

BILLING CODE 4910-59-P

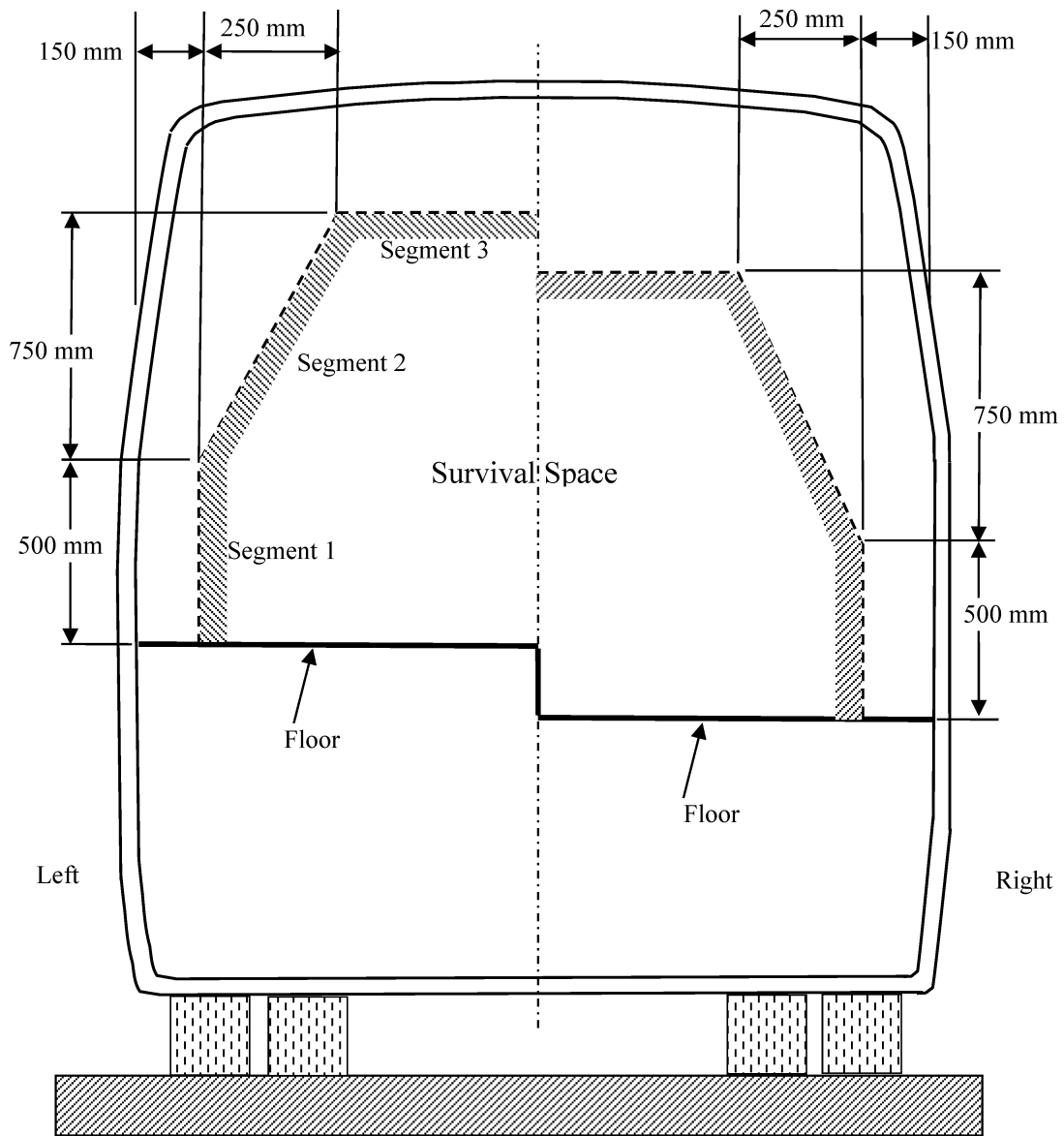

**Figure 1 to § 571.227: Survival Space
(Rear View - For Illustration Purposes)**

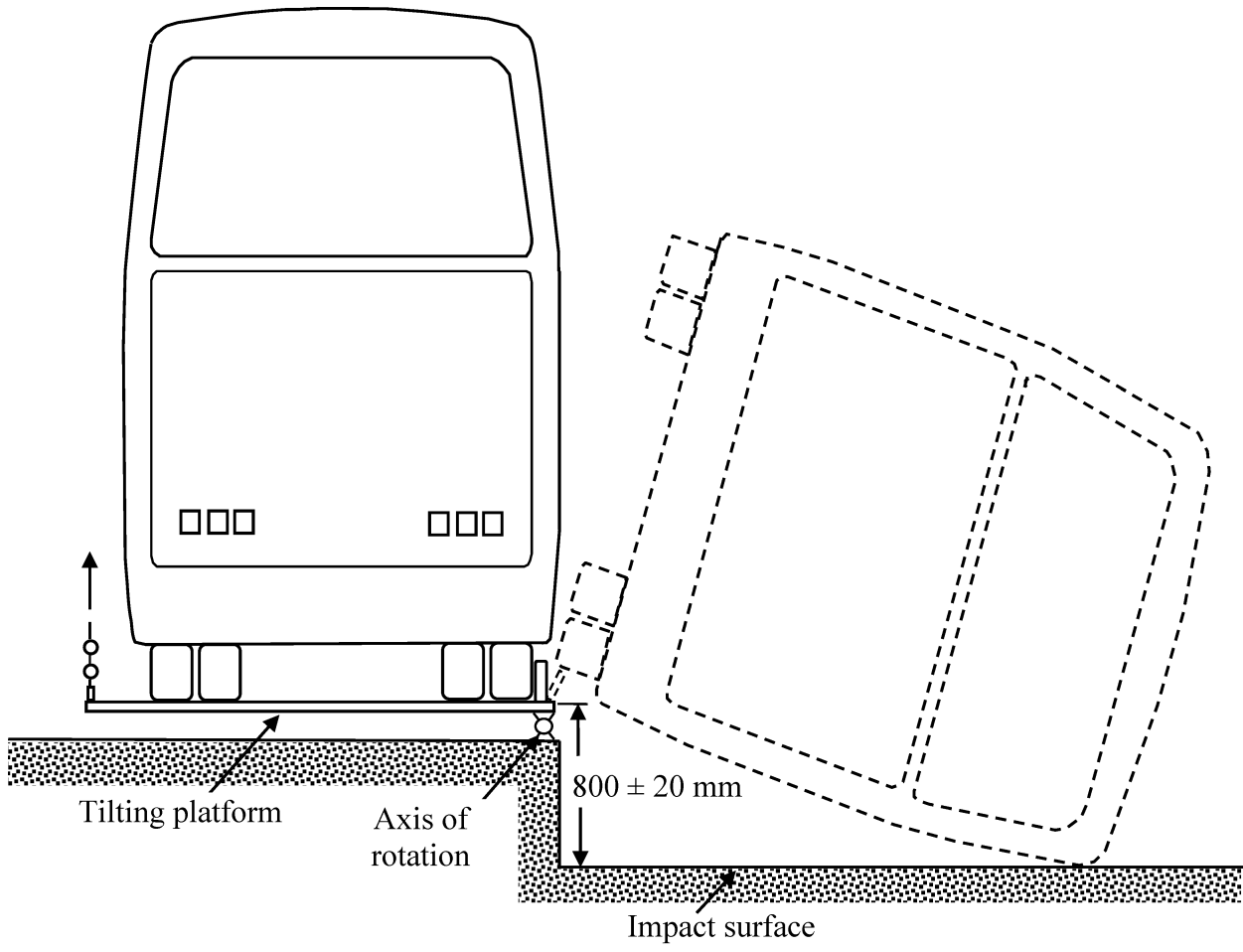

**Figure 2 to § 571.227: Vehicle on Tilting Platform
(Rear View – For Illustration Purposes)**

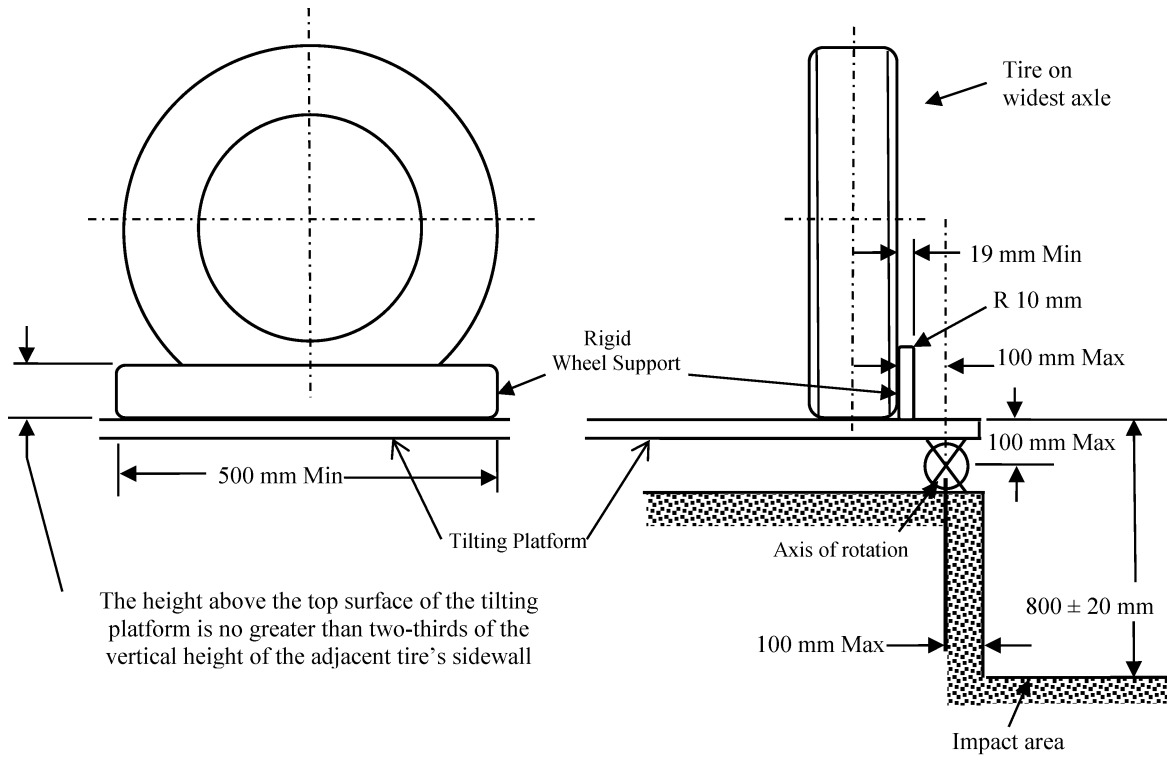

**Figure 3 to § 571.227: Axis of Rotation
(For Illustration Purposes)**

Issued under authority delegated in 49 CFR 1.95.

Steven Cliff,
Deputy Administrator.

[FR Doc. 2021-27538 Filed 12-28-21; 8:45 am]

BILLING CODE 4910-59-C