



# ADS Crash Safety

*NHTSA Safety Research Portfolio Public Meeting: Fall 2021*

*October 21, 2021*

# Background/Motivation

---

- NHTSA is researching the safety of occupants in vehicles equipped with Automated Driving Systems (ADS)
- Expect to see more...
  - Reclined seating
  - Rear-seat occupants
  - Rear-impact kinematics
  - Children in different seat positions/configurations
  - Unoccupied vehicles
- Research Areas
  - Biomechanical response and injury mechanisms from post-mortem human surrogates (PMHS)
  - Assessment of human body models
  - Assessment, modification of existing ATDs

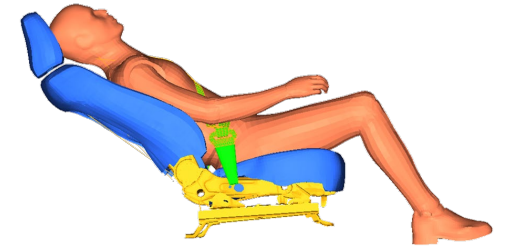
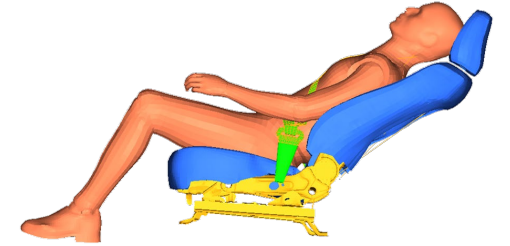

## Content Warning

Some content in this session depicts post-mortem human surrogates (PMHS), or cadavers. NHTSA and its university research partners follow an Institutional Review Board process to ensure protection of the rights and welfare of human subjects of research. Viewer discretion is advised.



# Panel Presentations

1

## **Forward Facing Crash Safety**

Dan Parent

2

## **Rear Facing Crash Safety**

Jason Stammen

3

## **Vehicle Compatibility in Unoccupied ADS**

Ian Hall

4

## **Unconventional Child Seating Environments**

Ian Hall

# Forward-Facing Crash Safety

*Dan Parent*

# Forward-facing Reclined: Introduction

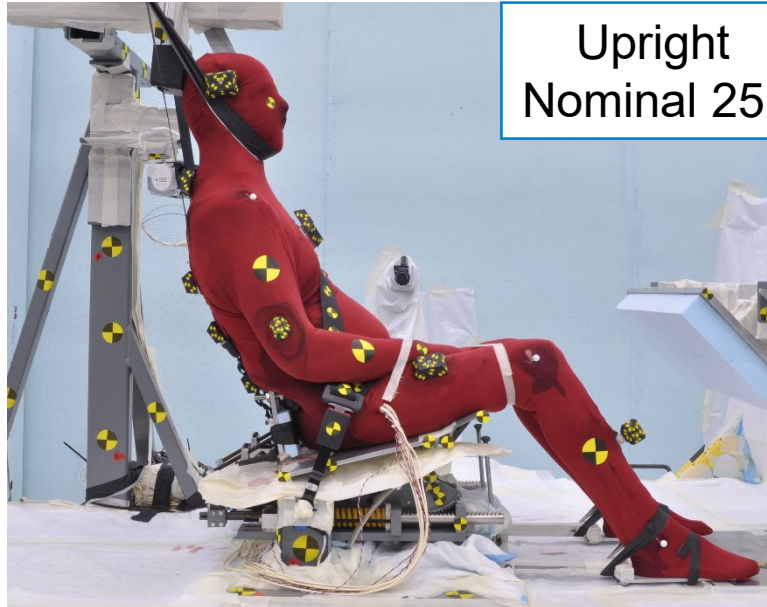

## Research question

- Current knowledge of human response and injury mechanisms in motor vehicle crashes is based on human surrogate response in upright postures. How would a reclined posture change kinematics and injury mechanism(s)?

## Approach

- Collect data on occupant response in a repeatable laboratory condition to compare upright to reclined postures in frontal impacts (forward-facing in a frontal crash or rear-facing in a rear crash)

# Forward-facing Reclined: Methodology

## Test Apparatus

- Spring-controlled seat ([Uriot et al., 2015](#))
- Adjustable, open seatback
- Adjustable, padded knee bolster

## Crash Pulse

- Frontal rigid barrier crash test
- Low-speed: 15 kph or 32 kph
- High-speed: TBD

## Subject positioning

- Target volunteer postures ([Reed et al., 2018](#))

## Instrumentation

- 6DOF sensors (head, spine, pelvis, legs)
- Strain gages (ribs, clavicles, sternum, ASIS)
- 3D motion tracking (TEMA or VICON)

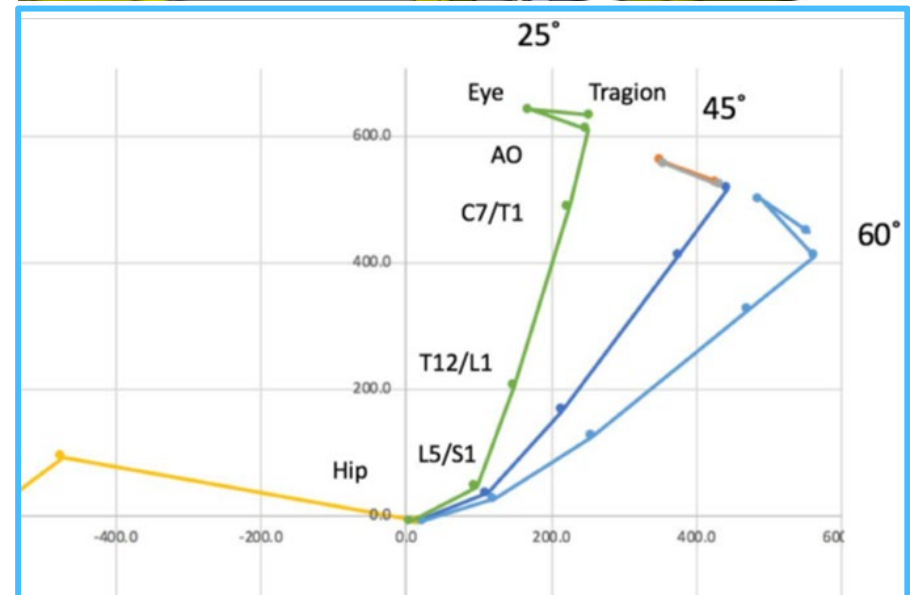
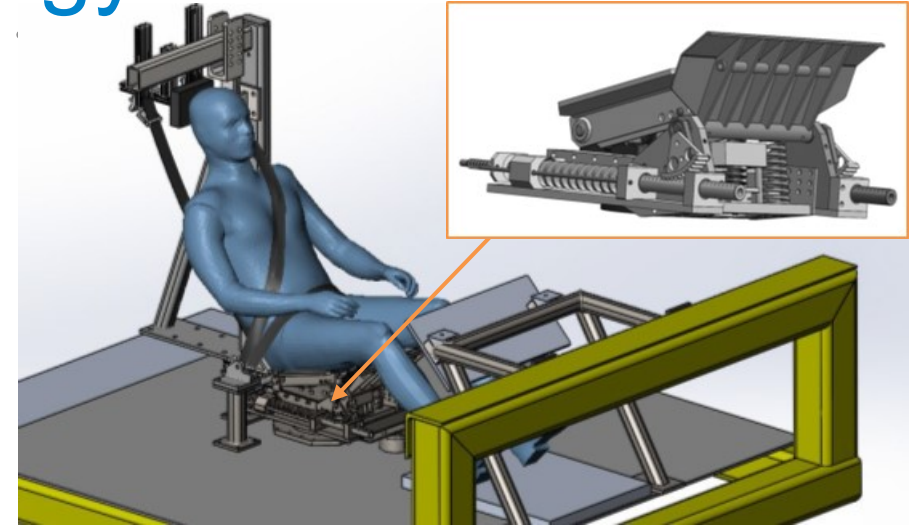

# Forward-facing Reclined Test Matrix

## Phase I: 50<sup>th</sup> Male

TSTNO	TSTREF	Delta V (kph)	Seat Back Angle	Sex	Age	Weight (kg)	Stature (cm)
12795	AV2002	32	45°	M	91	76	175
12796	AV2003	32	25°	M	72	64	174
13109	AV2104	32	25°	M	80	80	169
13110	AV2105	32	45°	M	85	71	170
13119	AV2106	32	25°	M	71	53	166
13124	AV2107	32	45°	M	70	64	176

Click here to download photos, videos, reports, and data from these tests

## Phase II: Obese / Small Female

TSTNO	TSTREF	Delta V (kph)	Seat Back Angle	Sex	Age	Weight (kg)	Stature (m)
13111	NAVSC101	15	45°	F	59	105	160
13112	NAVSC102	32					
13113	NAVSC103	15	45°	M	70	96	169
13114	NAVSC104	32					
13115	NAVSC105	15	45°	F	64	59	153
13116	NAVSC106	32					
13117	NAVSC107	15	45°	F	51	50	154
13118	NAVSC108	32					
13120	NAVSC109	15	25°	F	77	108	162
13121	NAVSC110	32					
13122	NAVSC111	15	25°	F	78	54	166
13123	NAVSC112	32					
13125	NAVSC113	15	25°	F	78	109	183
13126	NAVSC115	32					
TBD	NAVSC116	15	25°	F	85	35	144
TBD	NAVSC117	32					

Detailed Task Implementation Plans: [http://mreed.umtri.umich.edu/AV\\_Safety\\_TIP/](http://mreed.umtri.umich.edu/AV_Safety_TIP/)



# Forward-facing Reclined: Deliverables

## Technical Data Package

- Instrumentation data
- Processed three-dimensional kinematics
- Media (photos, videos, medical imaging)
- Test report

## Additional Analysis

- Biofidelity corridors
- ATD matched pair testing
  - THOR-50M (with Modifications for Reclined Seating)
  - THOR-05F
- Human Body Model evaluation/improvement
- Injury criteria development

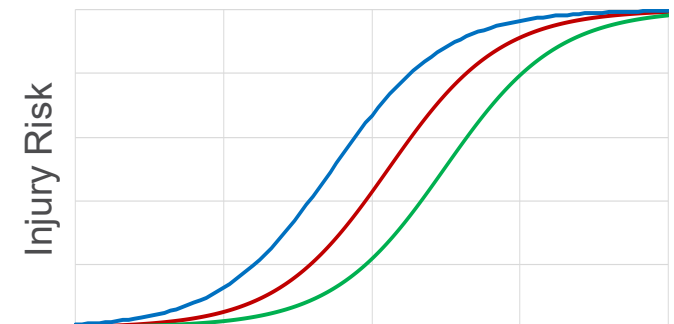
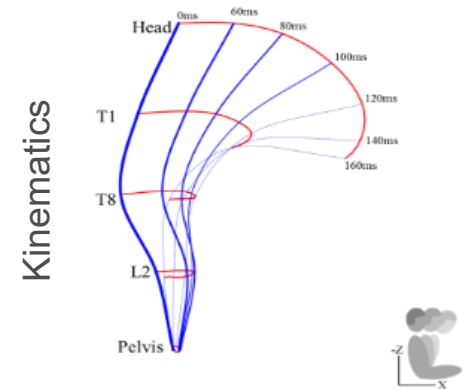
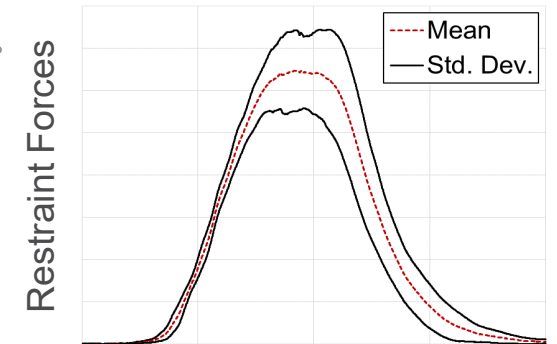

# THOR-50M Modifications for Reclined Seating

- Objective
  - Design and fabricate modified parts to address limitations in THOR-50M static positioning in reclined seats
- Tasks
  - Baseline static positioning assessment in 3 seats
  - Design and fabricate prototype parts
  - Incorporate design in THOR-50M FE model
  - Repeat baseline positioning assessment with modified THOR-50M
  - (Optional) Fabricate 3 additional sets of parts
  - **(New) Conduct sled tests**
- Key Outputs
  - 3D CAD package for modified parts
  - Static positioning assessment data
  - Sled test data
  - Updated THOR-50M FE model

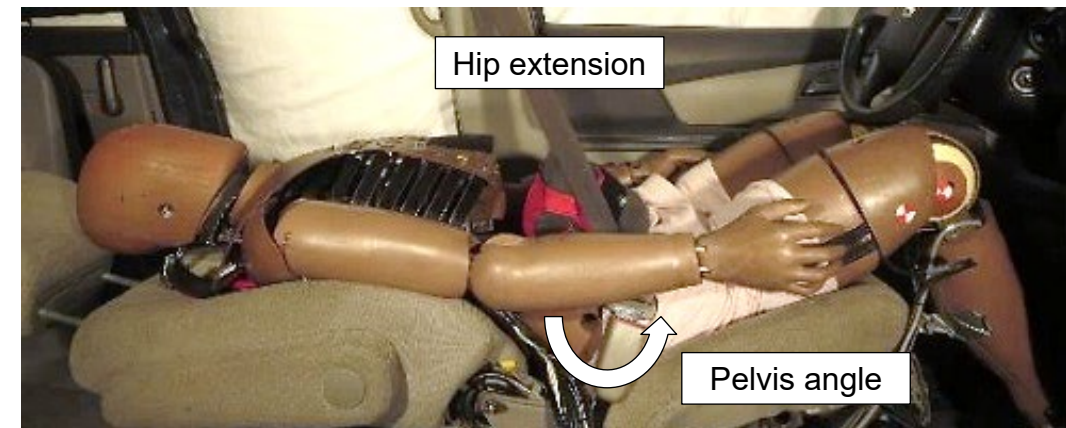
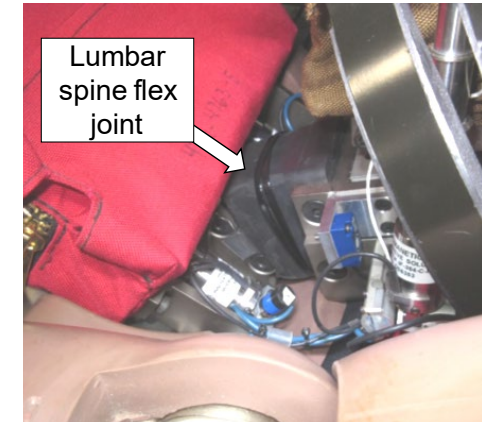
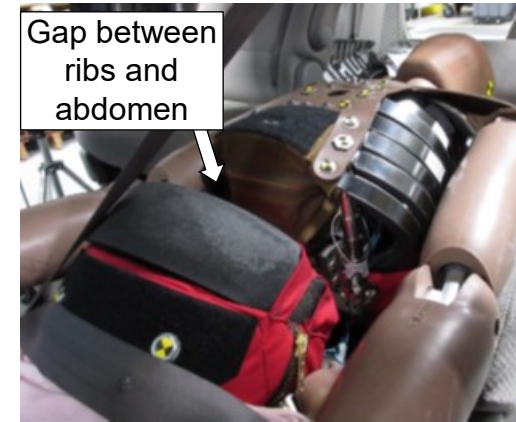

# THOR-50M Modifications for Reclined Seating

New Lower Thoracic Spine Flex Joint

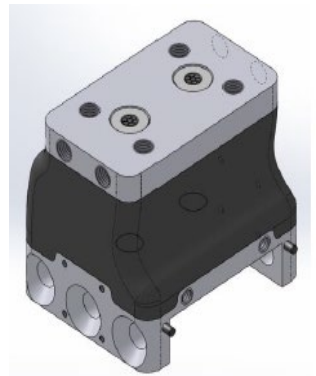
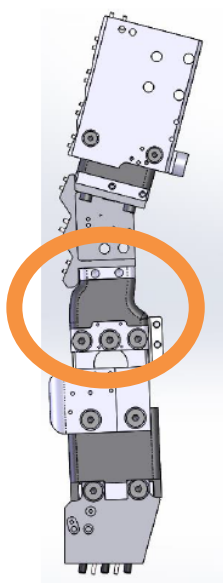

Modified Pelvis and Thigh Flesh



Unified Foam Abdomen

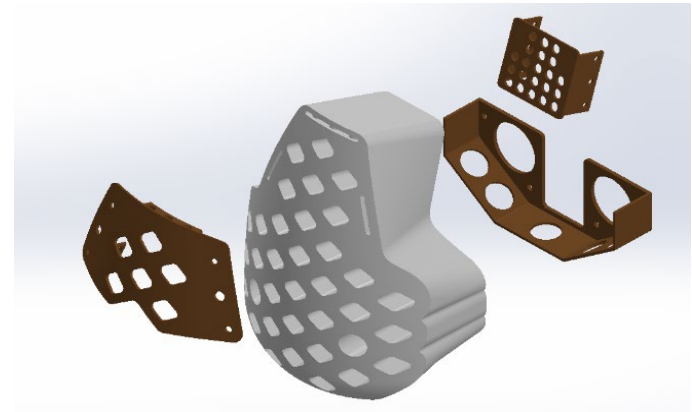

Modified Jacket

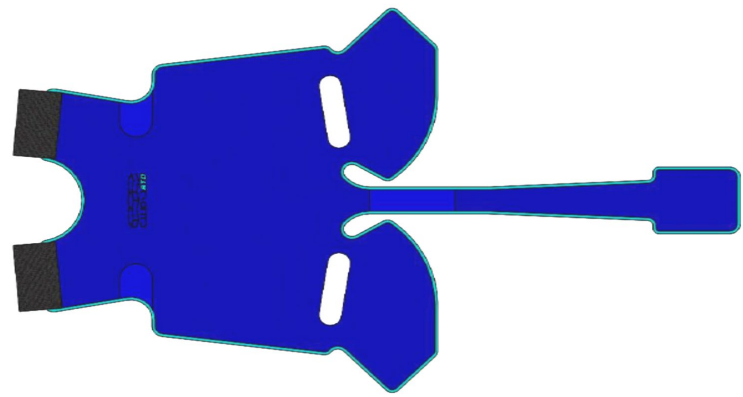

# THOR-50M Modifications for Reclined Seating

## Gold Standard 1

### Tasks

Baseline static positioning assessment in 3 seats

Incorporate design in THOR-50M FE model

Design and fabricate prototype parts

Install parts on THOR-50M, run qualification tests

Repeat static positioning assessment with modified THOR-50M

Conduct sled testing:

- Gold Standard 1: 40 km/h, standard 3-pt belt
- Gold Standard 2: 30 km/h, 3kN force-limited 3-pt belt
- Reclined: 50 km/h, semi-rigid seat, force-limited and pretensioned 3-point belt

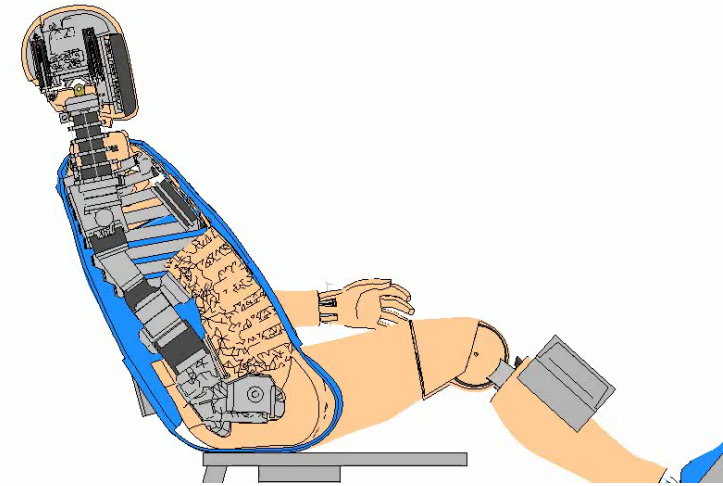

## Reclined

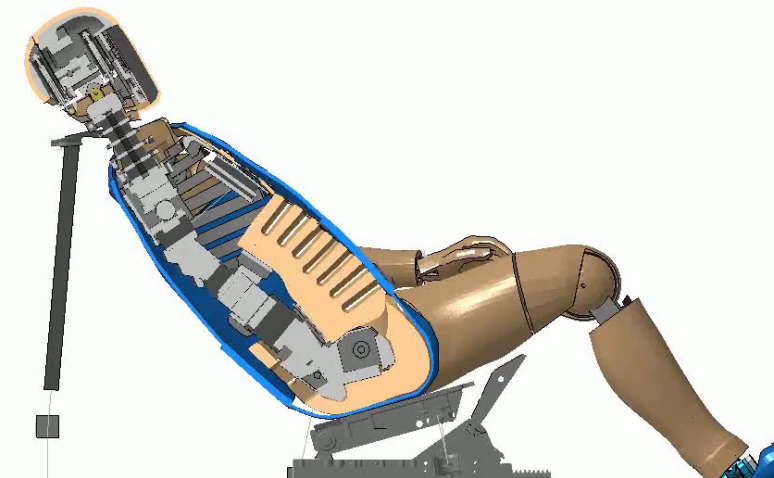

# THOR-50M Modifications for Reclined Seating

## Publications

Venue	Location/Link
Baseline Static Positioning Assessment Report	NHTSA Biomechanics Database <a href="https://www-nrd.nhtsa.dot.gov/database/MEDIA/GetMedia.aspx?tstno=12990&amp;index=1&amp;database=B&amp;type=R">https://www-nrd.nhtsa.dot.gov/database/MEDIA/GetMedia.aspx?tstno=12990&amp;index=1&amp;database=B&amp;type=R</a>
Occupant Protection for ADS-Equipped Vehicles Docket	NHTSA-2019-0123-0002 <a href="https://www.regulations.gov/document/NHTSA-2019-0123-0002">https://www.regulations.gov/document/NHTSA-2019-0123-0002</a>
2021 SAE Government-Industry Digital Summit	NHTSA Website <a href="https://www.nhtsa.gov/node/103691">https://www.nhtsa.gov/node/103691</a>
2021 RCCADS Workshop	TRC RCCADS Website <a href="https://trcpg.com/wp-content/uploads/2021/06/RCCADS-2021-Forman_Modifications-to-the-THOR-50M-for-Improved-Usability-in-Reclined-Postures.pdf">https://trcpg.com/wp-content/uploads/2021/06/RCCADS-2021-Forman_Modifications-to-the-THOR-50M-for-Improved-Usability-in-Reclined-Postures.pdf</a>

# Automated Wheelchair Securement System

## • Objective

- To develop a prototype automated wheelchair tiedown and occupant restraint system (AWTORS) that can be used without assistance by a person using a wheelchair

## • Design Components

- Automated wheelchair docking system using Universal Docking Interface Geometry (UDIG)
- Automated seat belt donning system
- Self Conforming Rearseat Air Bag (SCaRAB)
- Center Airbag To Contain Humans (CATCH)

## • Key Outputs

- Volunteer usability testing data
- Design drawings, demonstration
- Sled test data
- More Information: [Wheelchair Transportation Safety Open House](#)

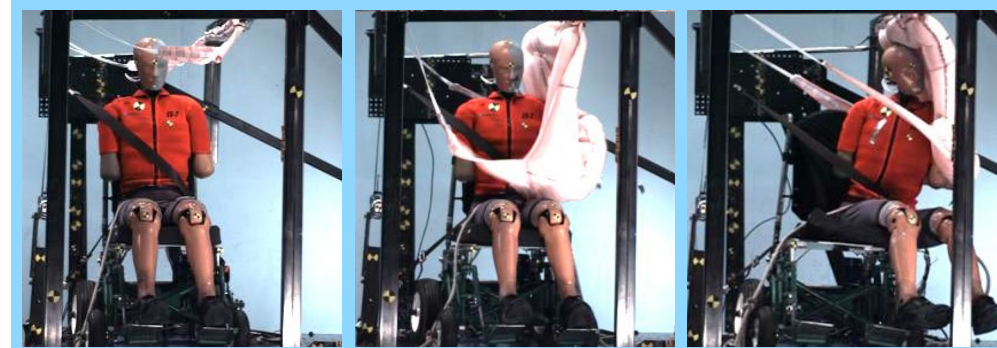
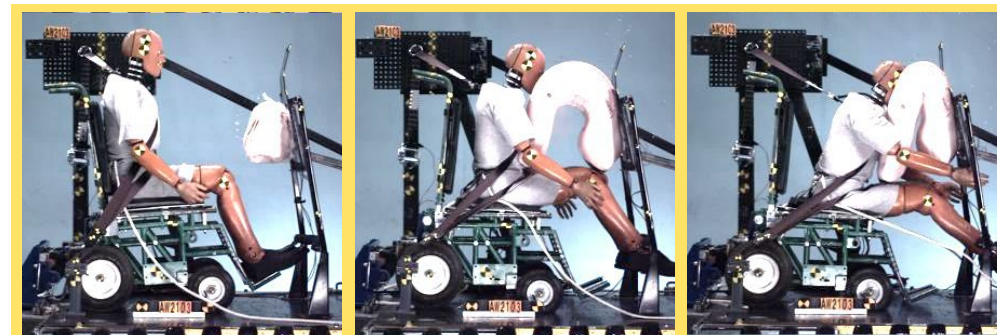
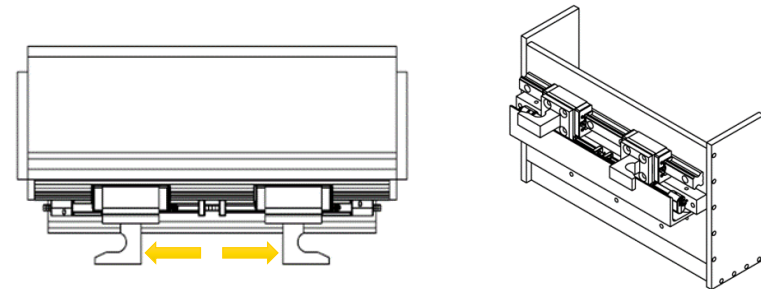

# Rear Seat Occupant Protection

---

- Objective
  - Improve understanding of rear seat occupant response and injury risk, as Automated Driving Systems-Dedicated Vehicle (ADS-DV) occupants may be more likely to self-select a rear seat
- Completed Tasks
  - Assessment of expected performance based on seat geometry, features, and restraint system
  - Computational simulations of rear seat response in frontal NCAP environment
  - Sled testing using Hybrid III, THOR 50<sup>th</sup> percentile male ATDs in 7 vehicle bucks
  - Report to be published in National Transportation Library
- Ongoing Tasks
  - Sled testing using PMHS (N=12) in 4 vehicle bucks
  - Seating Preference Study

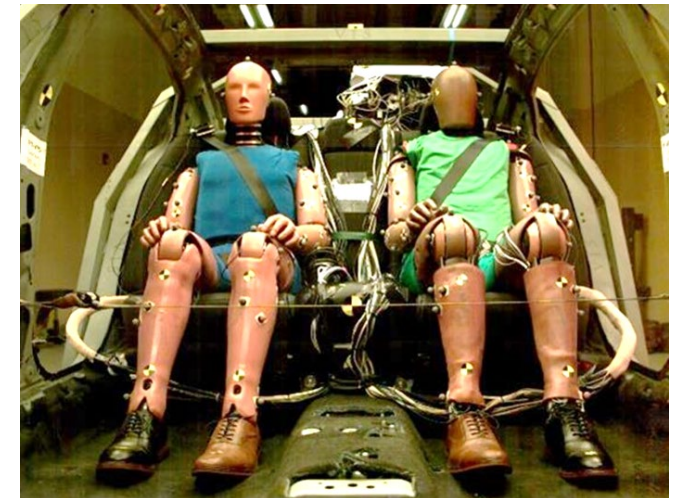
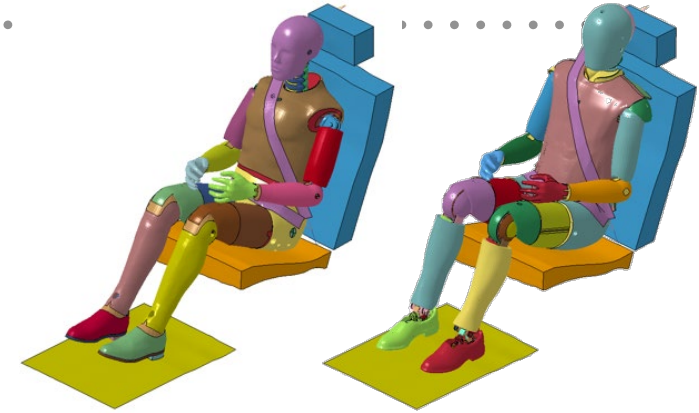

# Rear Seat Occupant Protection – ATD Sled Testing

Buck	Pretensioner & Load Limiter	Delta-V (km/h)	Submarining Severity	Description
V1	Y	32	Minor	Right Side
		56	None	
V6	N	32	None	
		56	None	
V10	N	32	Moderate	Bilateral
		56	Severe	Bilateral
V13	N	32	Moderate	Bilateral
		56	Severe	Bilateral
V14	Y	32	None	
		56	None	
V15	N	32	Minor	Right Side
		56	Moderate	Bilateral
V19	Y	32	Minor	Right Side
		56	Moderate	Bilateral





# ADS Lumbar Spine Response and Injury Risk

Awarded September 2021

- Background
  - Reclined postures, along with countermeasures to prevent them, may increase lumbar spine loads
- Objective
  - Characterize the current understanding of lumbar spine injury risk in motor vehicle crashes involving forward-facing
- Base Tasks
  - Literature Review
  - Assessment of Lumbar Spine Response Data
  - Assessment of Lumbar Spine Injury Criteria
- Optional Tasks
  - Human Body Finite Element Modeling
  - Post-Mortem Human Surrogate Testing

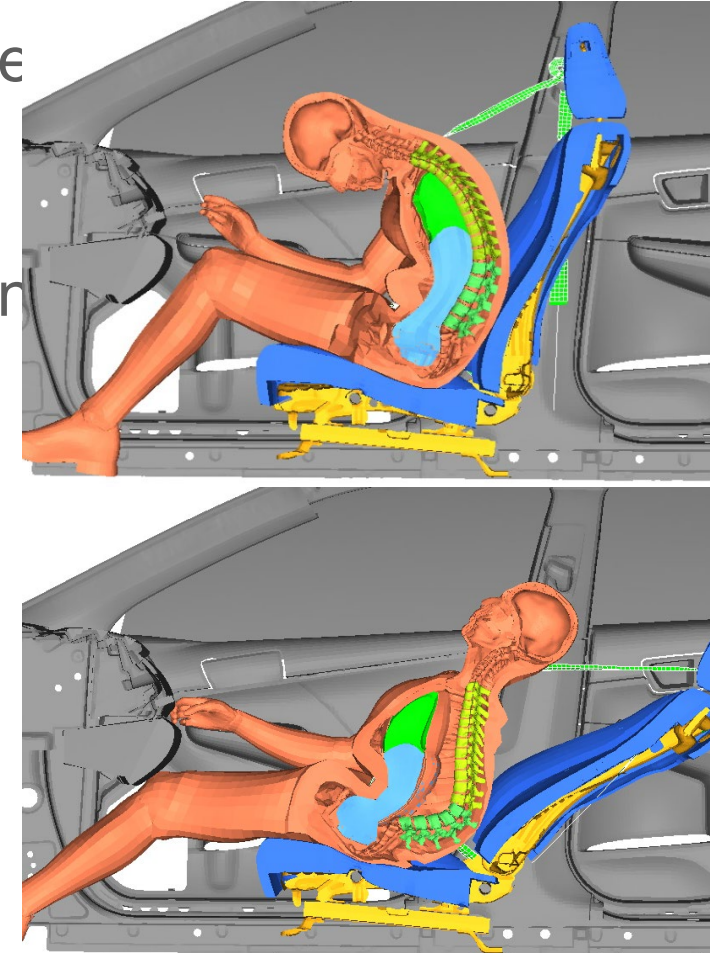

# Rear Facing Crash Safety

*Jason Stammen*

# Rear-Facing Upright/Reclined

- Two other potential ADS-equipped vehicle seating scenarios are **rear-facing in a frontal crash** or **forward-facing in a rear crash**
- NHTSA is generating new post-mortem human surrogate (PMHS)-based biomechanical data in those modes
- ATDs and human body models to be modified as needed to provide optimal injury risk assessment given this new PMHS data

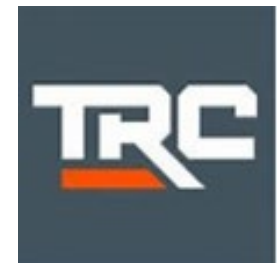
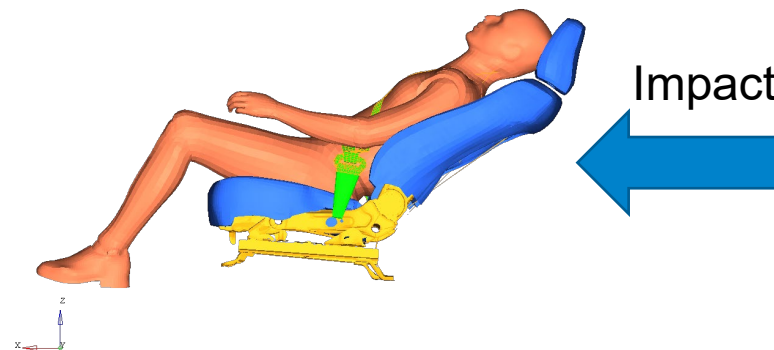
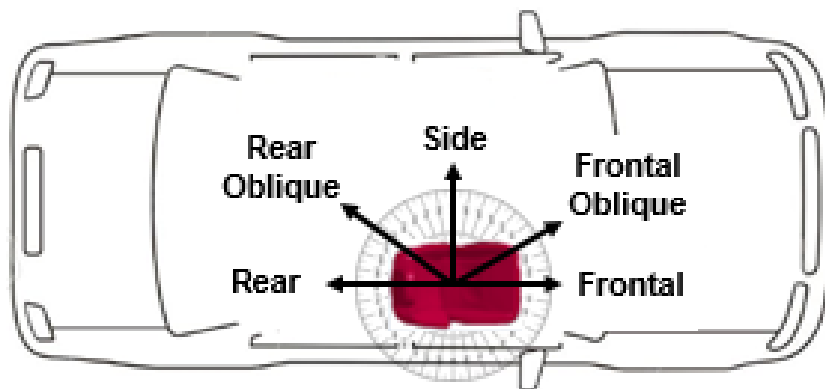

# Rear-Facing: Test Setup

- Repeatability: rigidized support to prevent seat back rotation – eliminates variation due to rotational stiffness when testing different seats
- Instrumentation: load cells to measure forces & moments at head restraint, seat back, and seat anchor points to floor
- Adjustability: can accommodate various recline angles, seats, PDOF, and speeds
- Tested two types of seats: (1) integrated belt (Honda Odyssey Row 2), (2) standard D-ring (Honda Accord Row 1)
- Tested both PMHS and THOR-50M in both 25 deg and 45 deg recline, at 24 kph and 56 kph

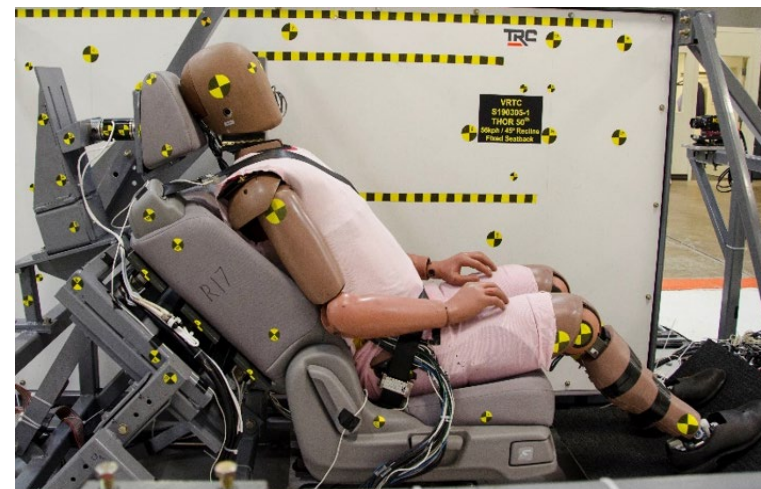

**Integrated Belt**

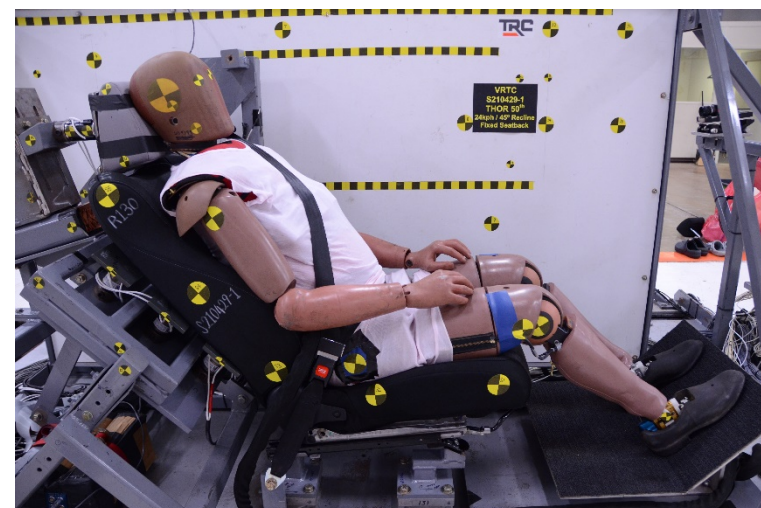

**Standard D-Ring**

# Rear-Facing: Occupant Positioning

- **Subject selection:** anthropometry close to 50<sup>th</sup> male ATD, no physical issues preventing sensor installation
- **Positioning:** for both PMHS and THOR-50M, match as closely as possible the volunteer postures from UMTRI study<sup>1</sup>
- **Head restraint location:** follow FMVSS 202a backset for standard seat back angle; maintain HR position relative to seat back when reclined

THOR-50M, 25° Seat back



PMHS, 25° Seat back



THOR-50M, 45° Seat back

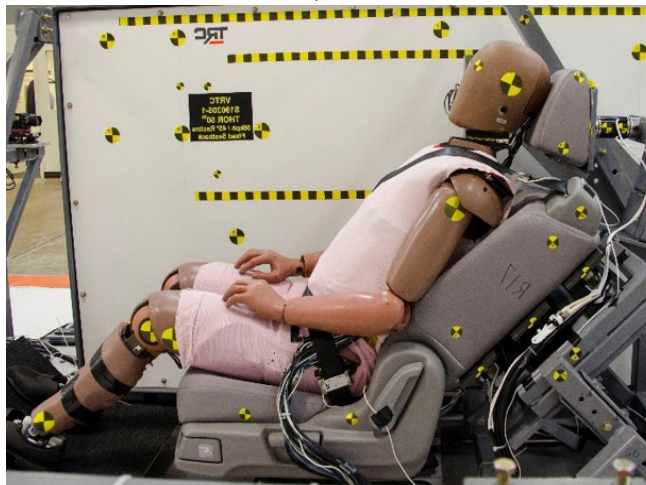

PMHS, 45° Seat back

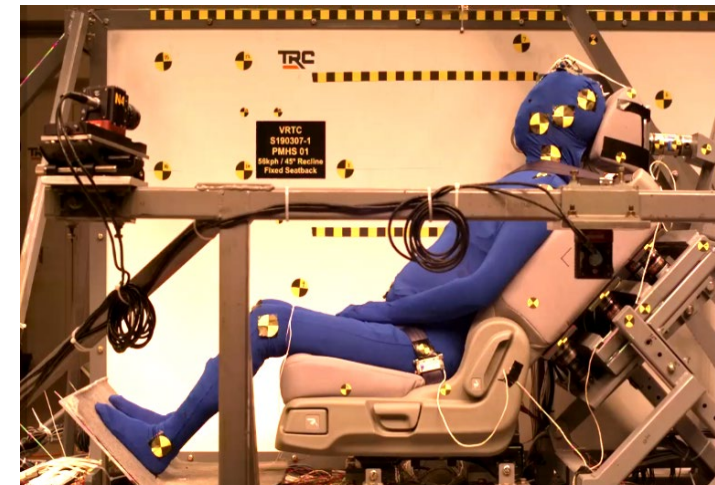

<sup>1</sup>Reed M, Ebert S. "Effects of Recline on Passenger Posture and Belt Fit" UMTRI-2018-2 (2018).

# Rear-Facing: Instrumentation

Sensor	THOR	PMHS
Head Accelerometers & Angular Rates Sensors (ARS)	X	X
Upper Neck Forces & Moments	X	
Upper & Lower Thorax IRTRACCs	X	
Chestband	X	X
T1 Accelerometers & ARS	X	X
T4 Accelerometers & ARS		X
T6 Accelerometers & ARS	X	
T12 Accelerometers & ARS	X	X
Acetabulum Forces & Moments	X	
Pelvis Accelerometers & ARS	X	X
Femur Force & Moments	X	
Femur Accelerometers, ARS, Strain Gages		X
Tibia Force & Moments	X	
Tibia Accelerometers, ARS, Strain Gages		X

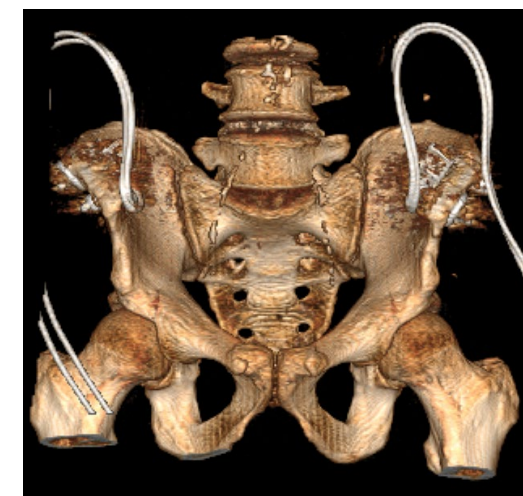
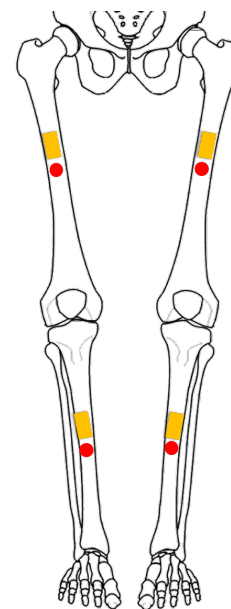
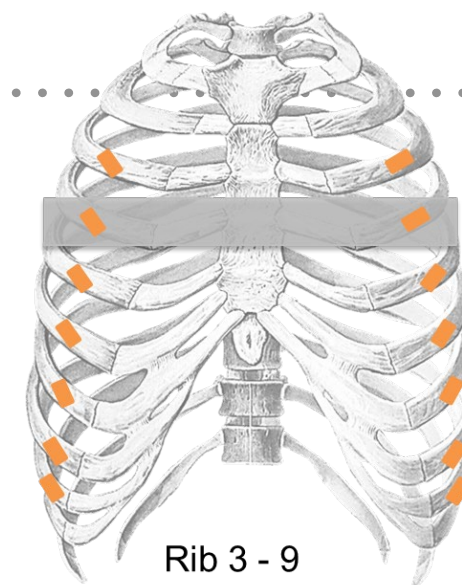
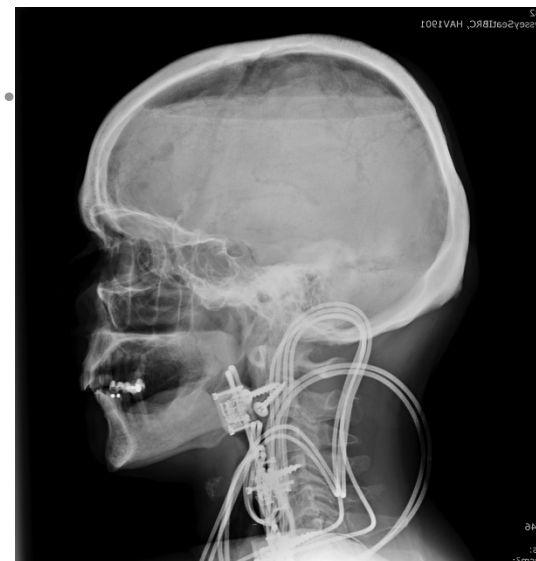

# PMHS Tests: Integrated Belt

- Biomechanical response corridors were generated to be used for evaluating current safety tools, such as ATDs and human body models (HBMs)
- Ramping of PMHS was larger in the 45-degree recline condition than in the 25-degree recline condition
- Although seat back reaction forces in the 25-degree recline condition were greater than those in the 45-degree condition, more rib fractures occurred in the 45-degree recline condition
- Shoulder and pelvis fractures occurred at 45 deg only
- No spine injuries occurred in either condition

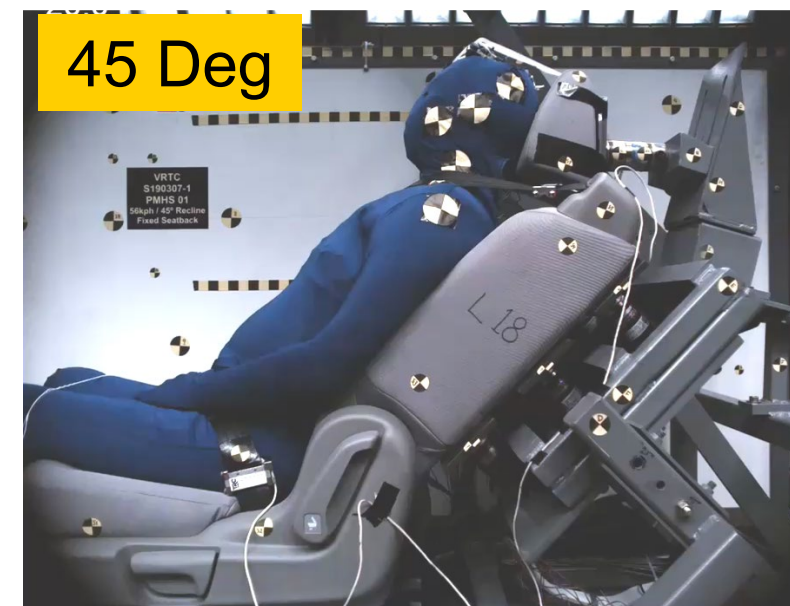
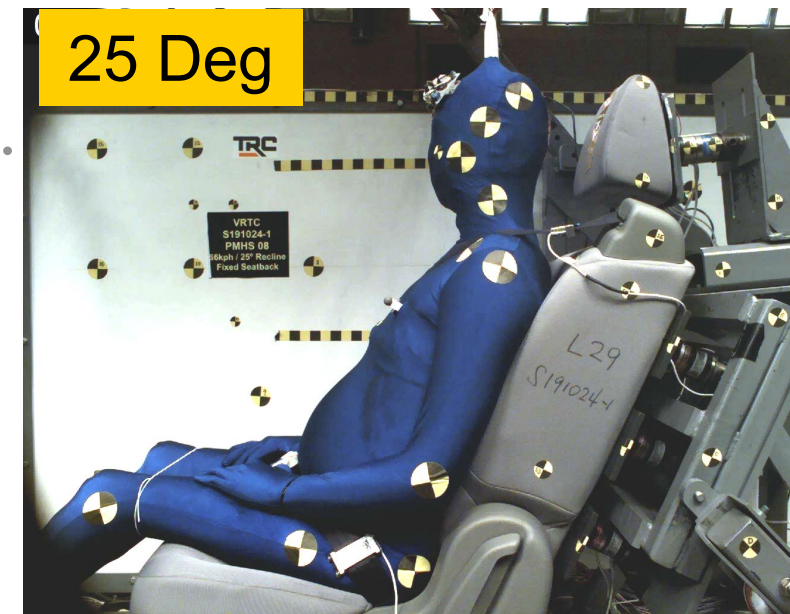

# PMHS Tests: Integrated Belt vs. D-Ring

- More injuries were observed in the standard D-ring belt than in the integrated belt, in particular with the 25-degree seat back angle.
- Higher ramping of the PMHS was observed in the standard belt than the integrated belt, since the standard belt was not able to hold the PMHS in place during the event.
- Seat back loads were higher in the standard belt than the integrated belt due to the softer seat back.
- No lumbar spine injuries were observed in either belt condition
- Off-axis rotation measured from both iliac wings may be an indicator for pelvis injuries in the rear-facing frontal impact.
- Details in upcoming SAE IJTS paper

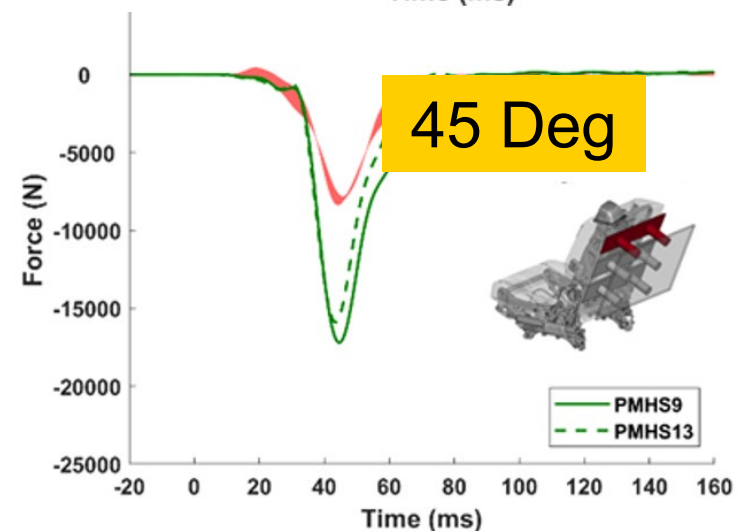
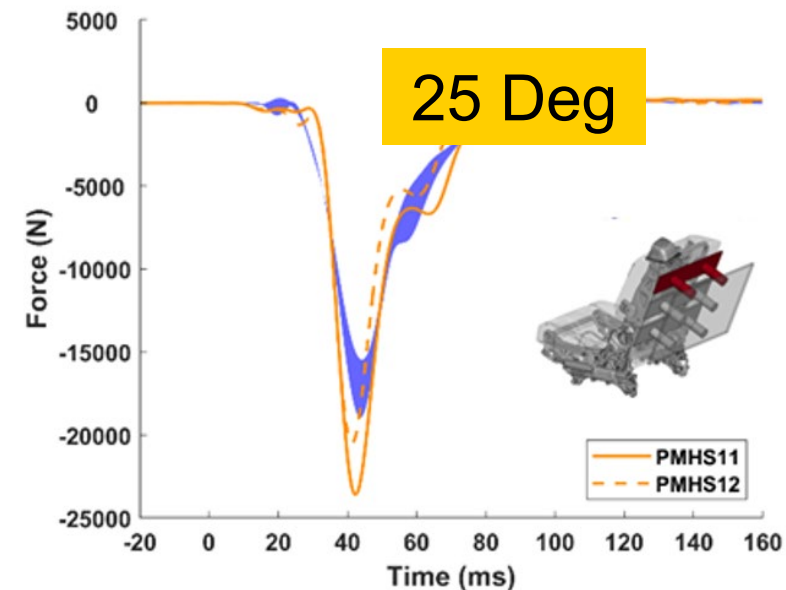



# Rear-Facing: Injury Mechanisms

- Test observations: many injuries – primarily rib and pelvis fractures due to seat interaction
- Examination of these injuries and the combined loading (seat back, seat cushion, belt) that is causing them

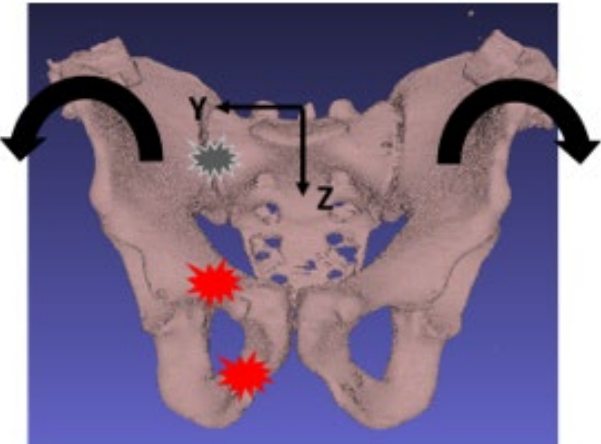
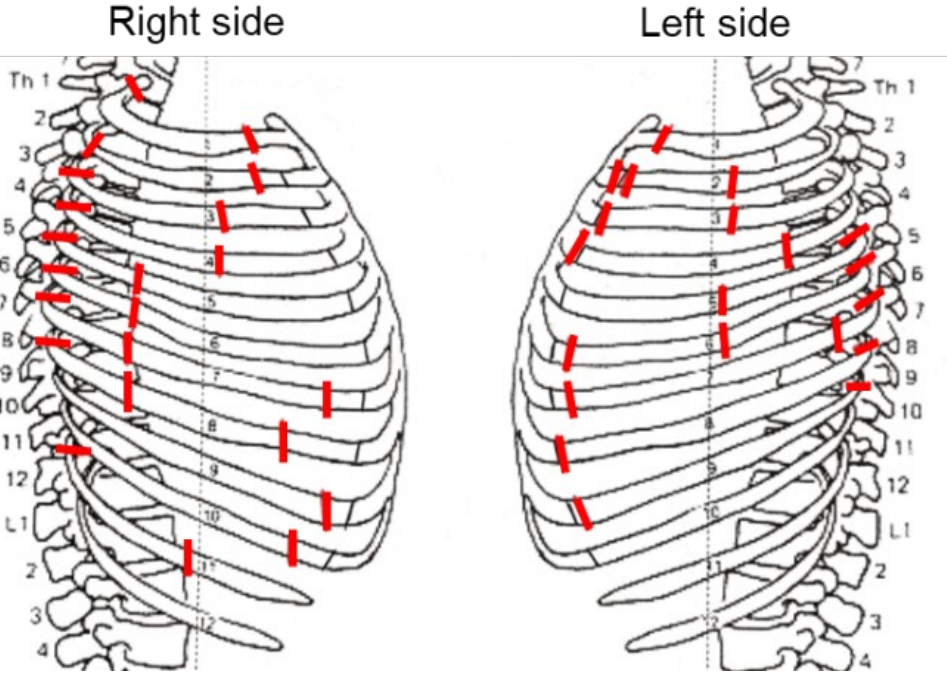

(a) A-P view for rotation about X-axis

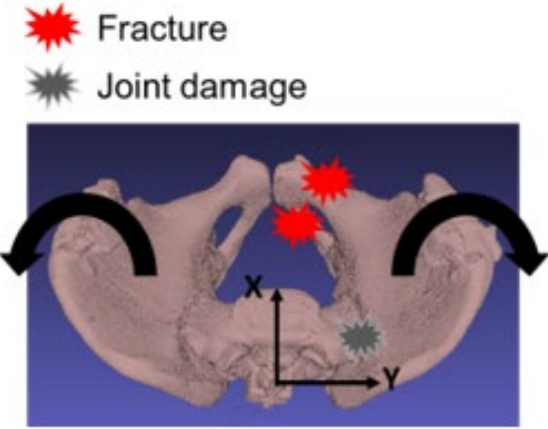

(a) S-I view for rotation about Z-axis

★ Fracture  
★ Joint damage

# THOR-50M Biofidelity

- Tested THOR-50M in same conditions as PMHS
- Applied an updated Biofidelity Ranking System (BRS) methodology
- THOR approximates human response reasonably well but there are some areas in need of improvement
- Details will be published in a SAE IJTS paper (early 2022)

Lower BRS  
score =  
better  
biofidelity

## THOR Biofidelity Summary

Location	25 deg BRS score	45 deg BRS score
HR Plate	1.56	1.98
Seatback Top Plate	1.94	1.71
Seatback Middle Plate	1.28	3.17
Seatback Bottom Plate	2.53	2.70
Belt Tensions	1.76	2.40
<b>SEAT LOADING</b>	<b>1.81</b>	<b>2.39</b>
Head	2.31	2.08
Spine	1.33	1.33
Thorax	1.89	1.37
Pelvis	2.48	1.53
<b>OCCUPANT RESPONSE</b>	<b>2.00</b>	<b>1.58</b>

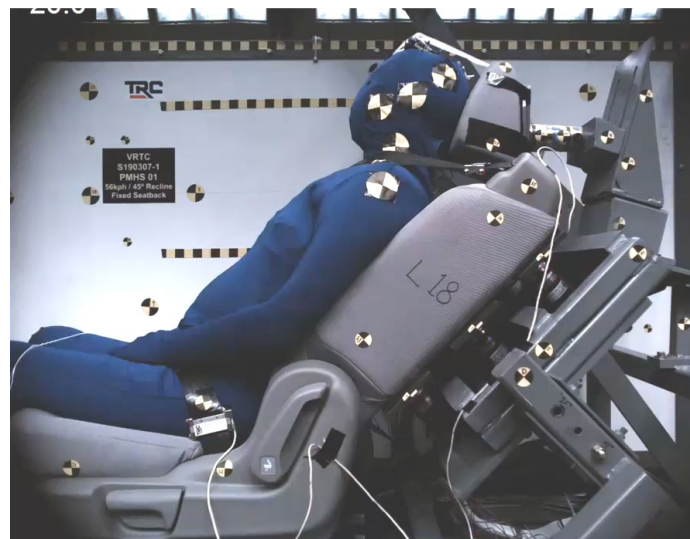

PMHS<sup>1</sup>

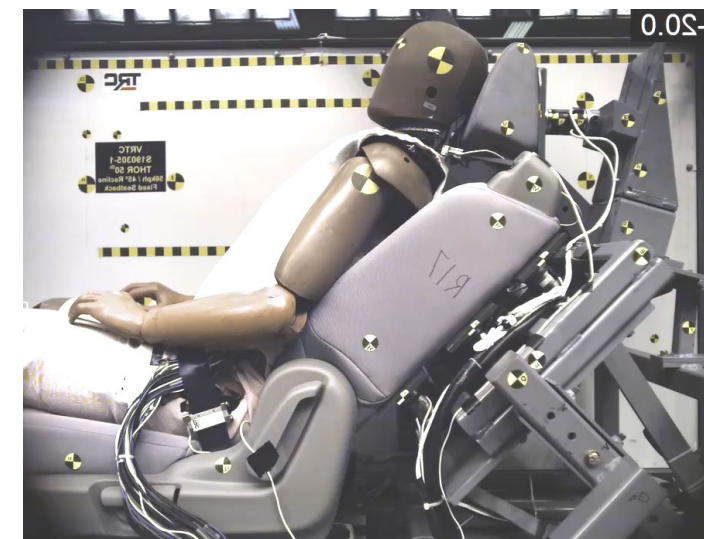

THOR 50<sup>th</sup> Male

# Evaluating Modified ATDs

- Identified design aspects of standard THOR-50M that need to be changed for rear-facing use:
  - Neck
  - Lumbar adjustment
  - Gap between ribcage and abdomen
  - Cable routing
- Evaluating two THOR ATDs that have modifications for reclined seating
  - THOR-AV (Humanetics)<sup>1</sup>
  - THOR-50M with reclined mods (UVA/Cellbond)<sup>2</sup>

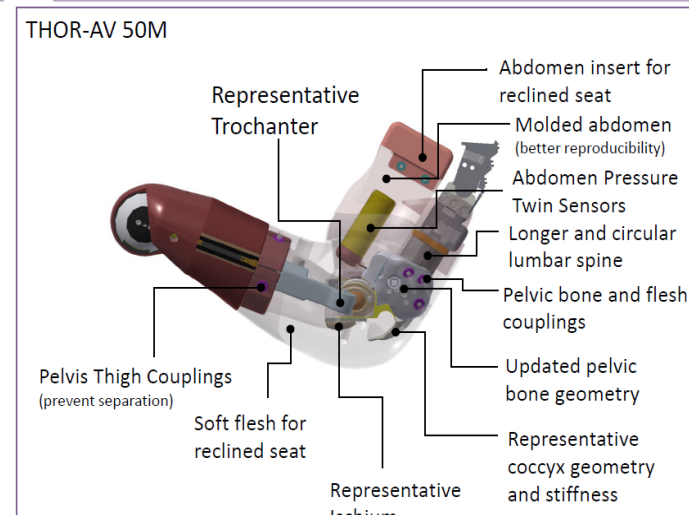
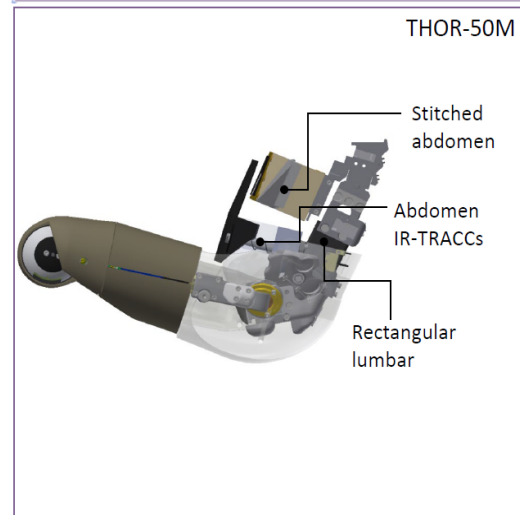
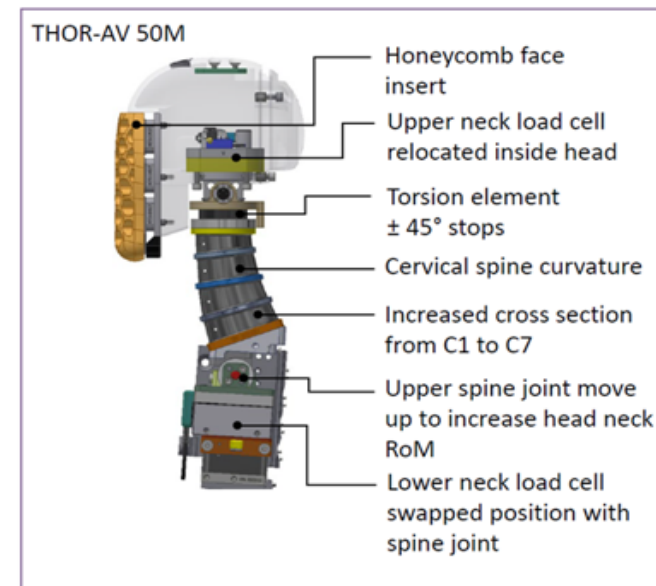
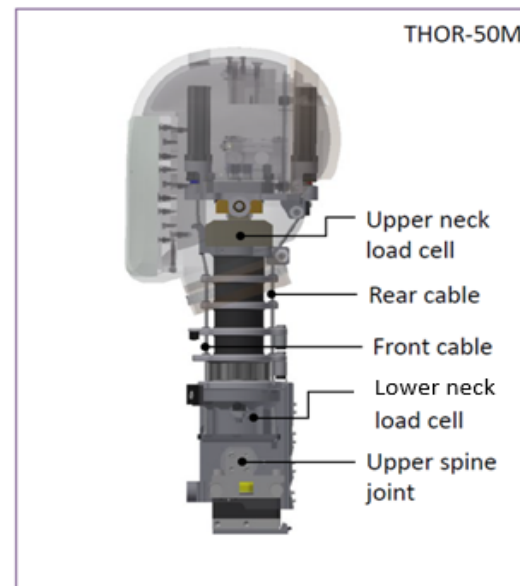

<sup>1</sup>Wang J. "THOR-AV Development and Biofidelity Evaluation" SAE Government/Industry Meeting (Feb 2021)

<sup>2</sup>Forman J. "Modifications to the THOR-50M for Improved Usability in Reclined Postures – Update and Preliminary Findings" SAE Government/Industry Meeting (Feb 2021)

# GHBMCM Biofidelity Analysis

- Evaluating GHBMCM biofidelity in the rear-facing condition
- Working out the details of the FE seat model to match experimental seat behavior
- Abdomen content motion in GHBMCM is one area that needs to be addressed

PMHS

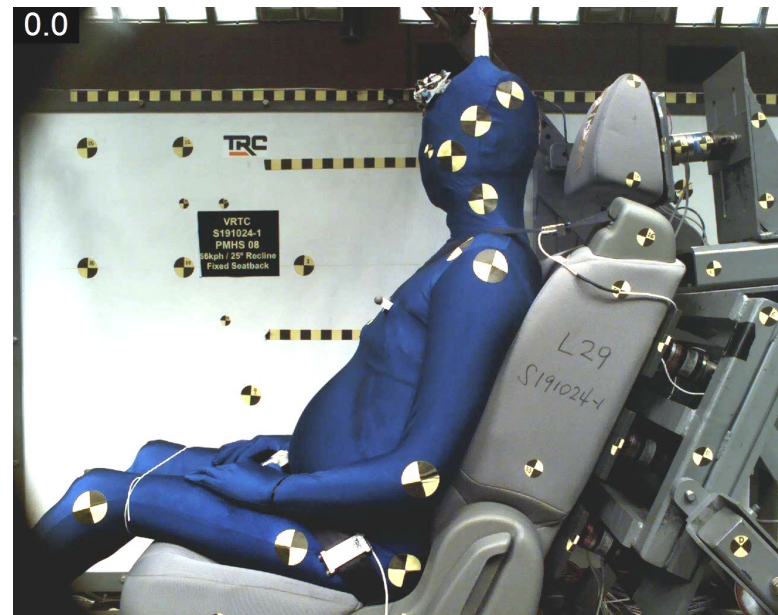

GHBMCM M50-O

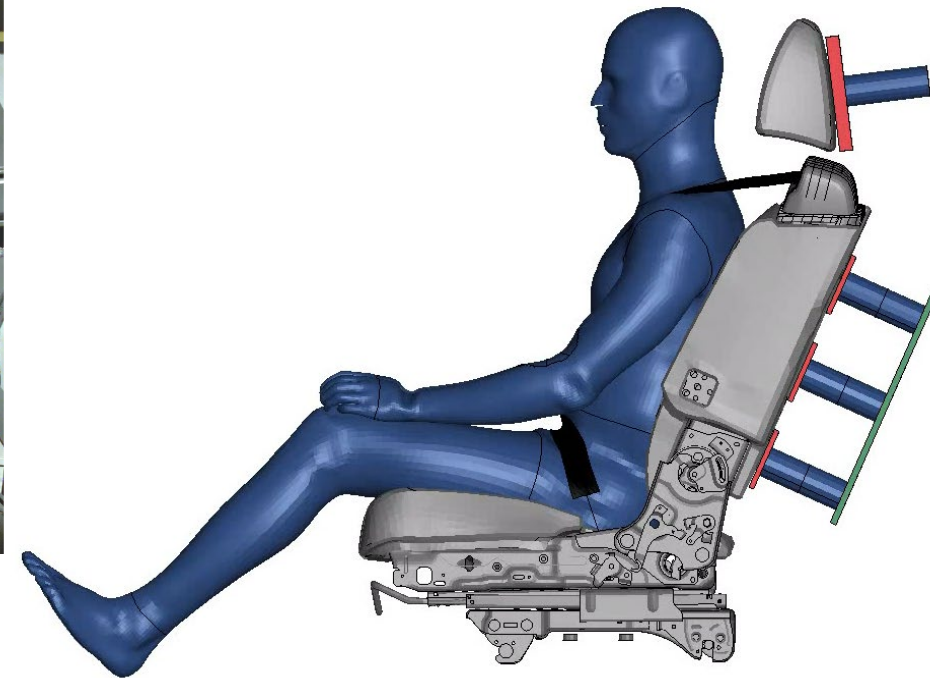

# Upcoming Tests

---

- Sled testing coming up soon
  - Effect of pretensioner on injury and kinematics
  - Other occupant size PMHS (small female, large male)
  - Other ATDs (THOR-05F)

# Information on Rear-Facing Tests

PMHS and ATD data from Odyssey/ABTS tests presented today are available in the NHTSA Biomechanics Database:

<https://www-nrd.nhtsa.dot.gov/database/VSR/bio/QueryTest.aspx>

(Search for test numbers 13077 – 13098)

Kang et al. (SAE Government/Industry 2019, 2020, & 2021)

Kang et al. (Stapp Car Crash Conference 2020) on PMHS responses & biofidelity targets in 56 kph Odyssey tests:

<https://saemobilus.sae.org/content/2020-22-0005/#abstract>

CAD files for both the Odyssey seat and ADS sled buck are found at:

<https://www.nhtsa.gov/crash-simulation-vehicle-models>

Buck: <https://www.nhtsa.gov/nhtsa-ftp?fid=63781#block-nhtsa-page-title>

Seat: <https://www.nhtsa.gov/nhtsa-ftp?fid=63786#block-nhtsa-page-title>

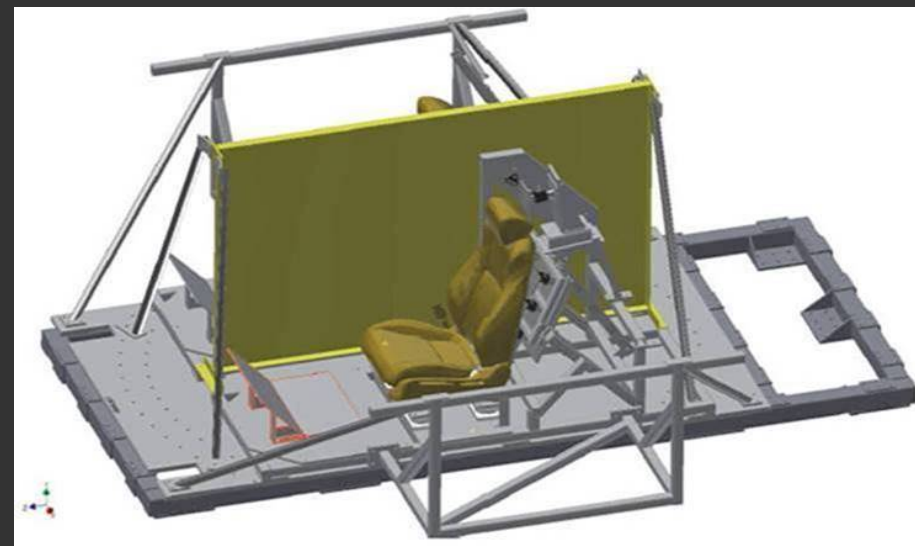

# Summary

---

- NHTSA is generating biomechanical data in high and low speed rear-facing, reclined seating scenarios so that ATDs and models can be evaluated and refined
- Results suggest potential for injuries to posterior ribcage, lower spine, pelvis, and lower extremities
- ATDs and HBMs will need to be revised for reclined seating and protection of rear-mounted instrumentation

For more information see  
Docket ID **NHTSA-2019-0123**  
NHTSA Crashworthiness  
Research - Occupant  
Protection for ADS-Equipped  
Vehicles Documentation

# Vehicle Compatibility in Unoccupied ADS

*Ian Hall*



# What are Unoccupied ADS-Equipped vehicles?

## • UADS Characteristics

- Delivery vehicles without a human driver.
- Operate across various sizes and Operational Design Domains (ODDs).
- Could be designed to protect the occupants of a crash partner vehicle.

## • Justification for Research

- Unoccupied ADS-Equipped vehicles (UADS) differ from occupied vehicles.
- Regulations related to occupant presence and occupant safety are not applicable.

## • Goal

- Study how geometry and stiffness variations in U-ADS vehicles affect occupant and structural responses in a crash partner.

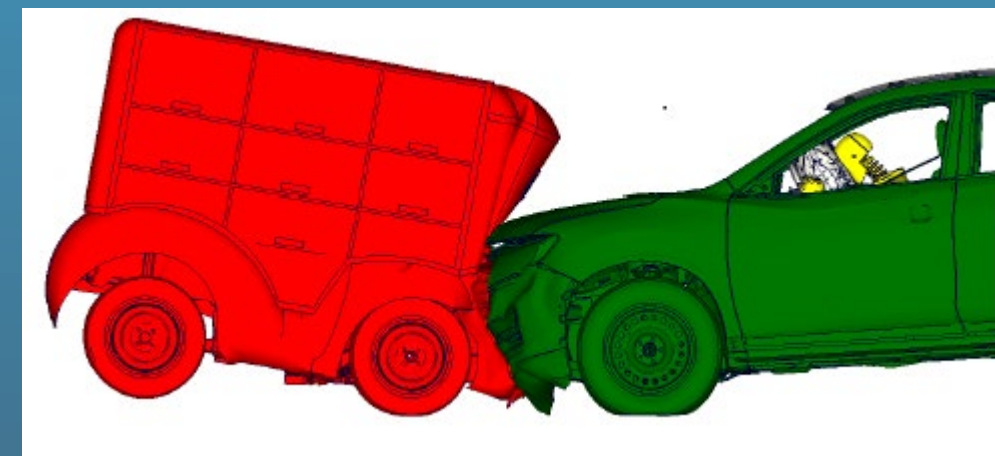

# Research Plan

## Literature Review and Scope

- Four main U-ADS vehicle size/ODD classifications.
  - Small Local (800 kg.,  $\leq 35$  km/h)
  - Mid-size (1500 kg.,  $\leq 40$  km/h)
  - Large (4000 kg.,  $\leq 45$  km/h)
  - Tractor Trailer (3400 kg.,  $\leq 50$  km/h)
- Two crash partner vehicles: Sedan and SUV.
- Real-world accident analysis studied conventional and ADAS-equipped vehicles
- Lit Review identified three main crash scenarios: Full Frontal, Frontal Oblique, and Side Impact.

## Compatibility Metrics

- Structural geometry of primary and secondary energy absorbing structures
- EuroNCAP Compatibility Assessment, including movable deformable barrier deformation characteristics, and Occupant Load Criteria.
- Crush Work Stiffness (Kw400)

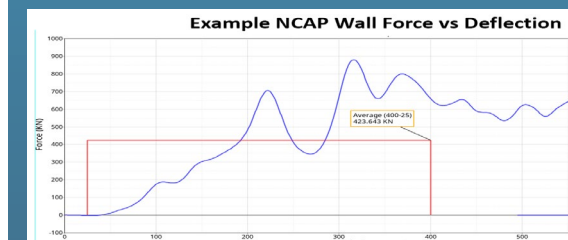
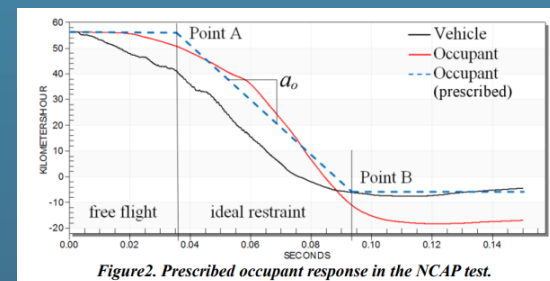
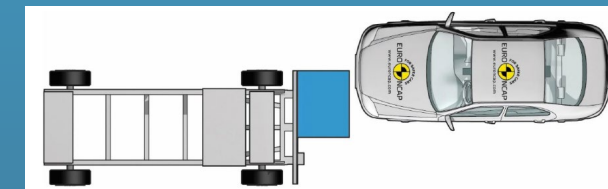
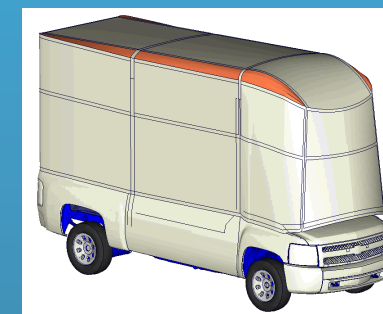
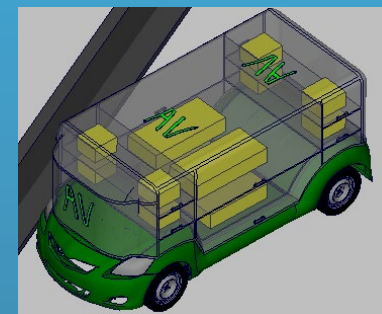

# Research Plan

## • Simulation Plan

- Conducted reference simulations for each crash partner.
  - Crash Partner to Rigid Wall
  - Crash Partner to EuroNCAP MPDB
  - FMVSS No. 214 Side Impact
  - IIHS Side Impact
- Conducted reference baseline U-ADS to crash partner impacts.
- Modified the front structure of the U-ADS vehicles to yield better or worse compatibility performance.
- Using U-ADS vehicles with modified frontal structural characteristics, we conducted modified U-ADS to Crash Partner impacts.
- Outputs are occupant and structural responses for the crash partner.

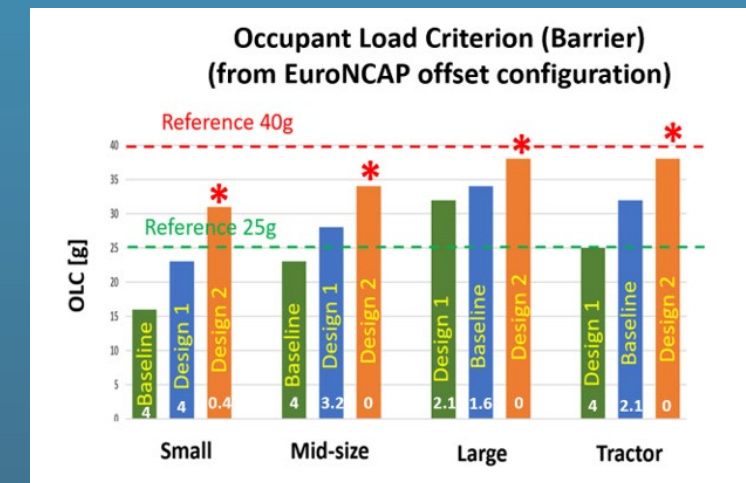
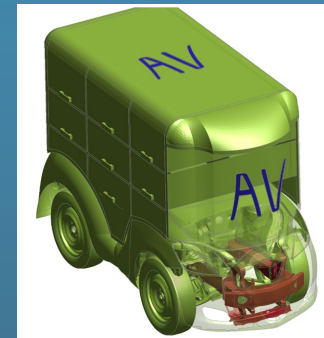
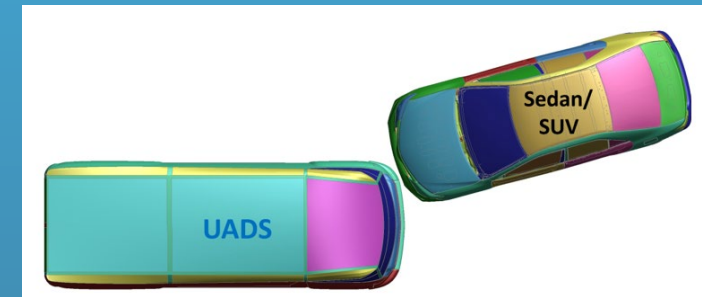
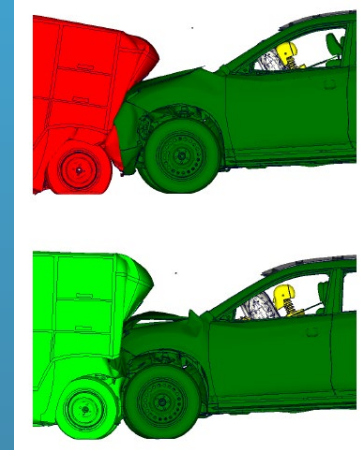

# Unconventional Child Seating Environments

*Ian Hall*

# Why study Unconventional Seating Environments?

## • Background

- Vehicle interiors are starting to change. ([AV Test](#))
- Future ADS-equipped vehicles may differ from current conventional vehicles.
  - No human driver and no steering wheel.
  - May not be in two or three distinct rows
  - May be rear-facing, lateral-facing, or be angled relative to the vehicle's motion.
- In terms of child safety, how would new unconventional seating orientations affect occupant responses?

## • Goal

- Study dynamic crash responses of 1YO – 10YO occupants in age-appropriate child seats in a variety of unconventional seating environments.

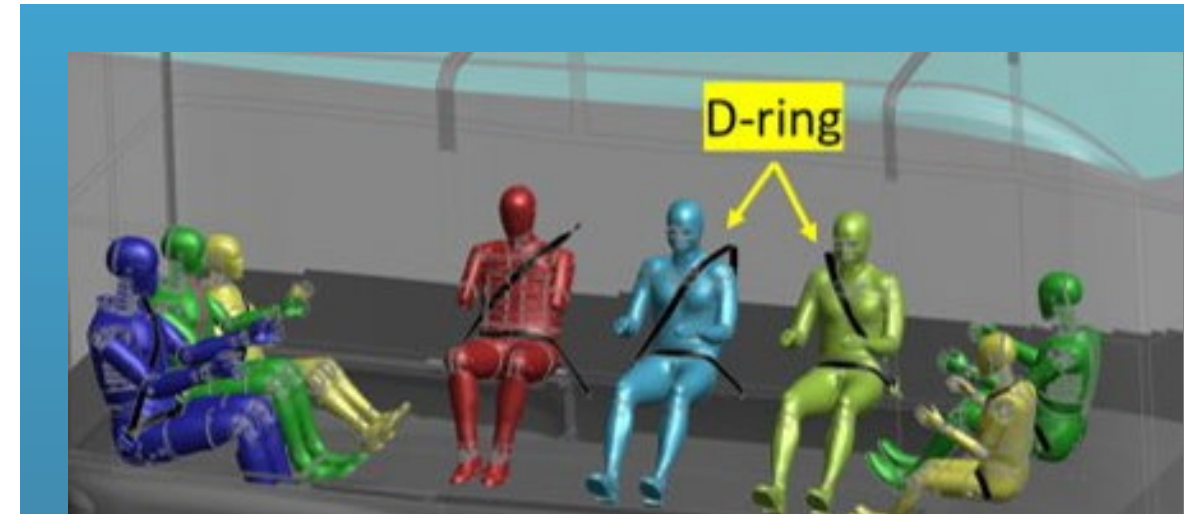

Source: <https://www.nhtsa.gov/automated-vehicle-test-tracking-tool>

# Research Plan

- Literature Review and Scope
  - Real-world accident analysis studied conventional and ADAS-equipped vehicles.
  - Crash scenarios
    - Frontal, frontal oblique, far-side.
    - Comparable pulse to frontal FMVSS No. 213.
  - Vehicle Environment
    - Minivan: Dodge Caravan.
    - Sedan: Ford Fiesta.
  - Seating Environment
    - Forward-facing, Rear-facing, Campfire.
    - Frontal bench, proposed in FMVSS No. 213 frontal NPRM.
  - Wide range of occupant ages in age-appropriate CRSs.
    - CRABI-12MO
    - Hybrid III - 3YO
    - Hybrid III - 6YO
    - Hybrid III - 10YO

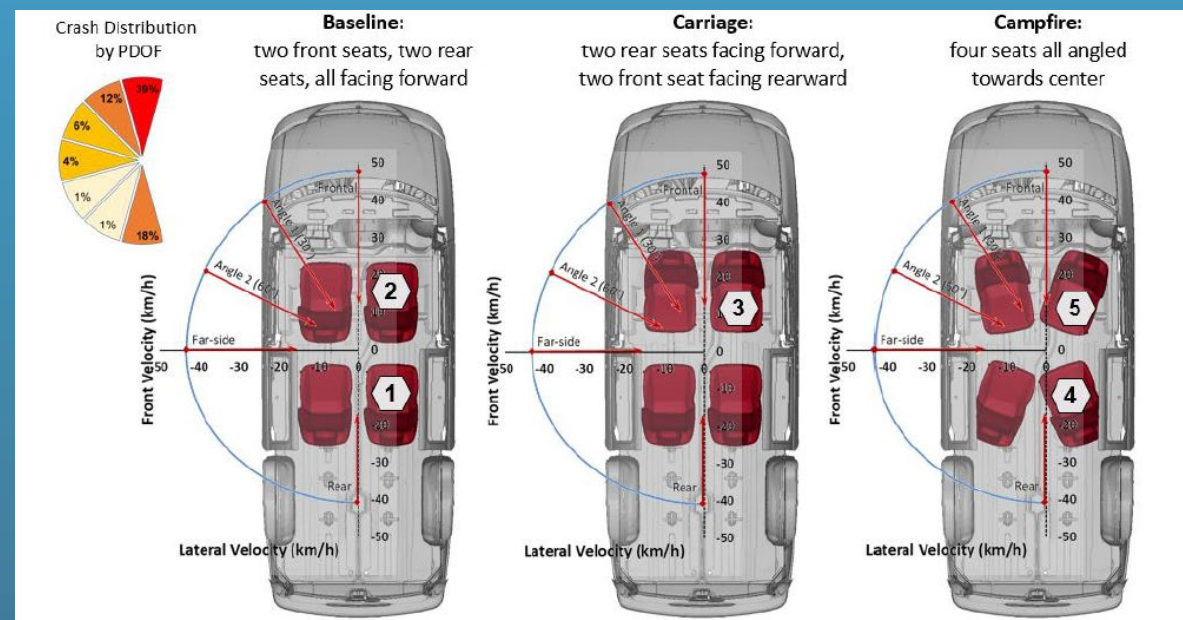

# Research Plan

## ■ Validation tests using 213 buck

- Pulse comparable to FMVSS No 213
  - Front, Frontal Oblique, Far-side, and Rear.
- Seating Environment
  - Frontal 213 buck proposed in frontal NPRM
  - Dodge Caravan vehicle seat for rear impacts

## ■ Simulation Plan

- Compare the responses of younger (1YO – 3YO) occupants in harnessed CRS in conventional vs. unconventional seating environments.
- Compare the responses of older (6YO – 10YO) occupants who use boosters or the vehicle seat in conventional vs. unconventional seating environments.

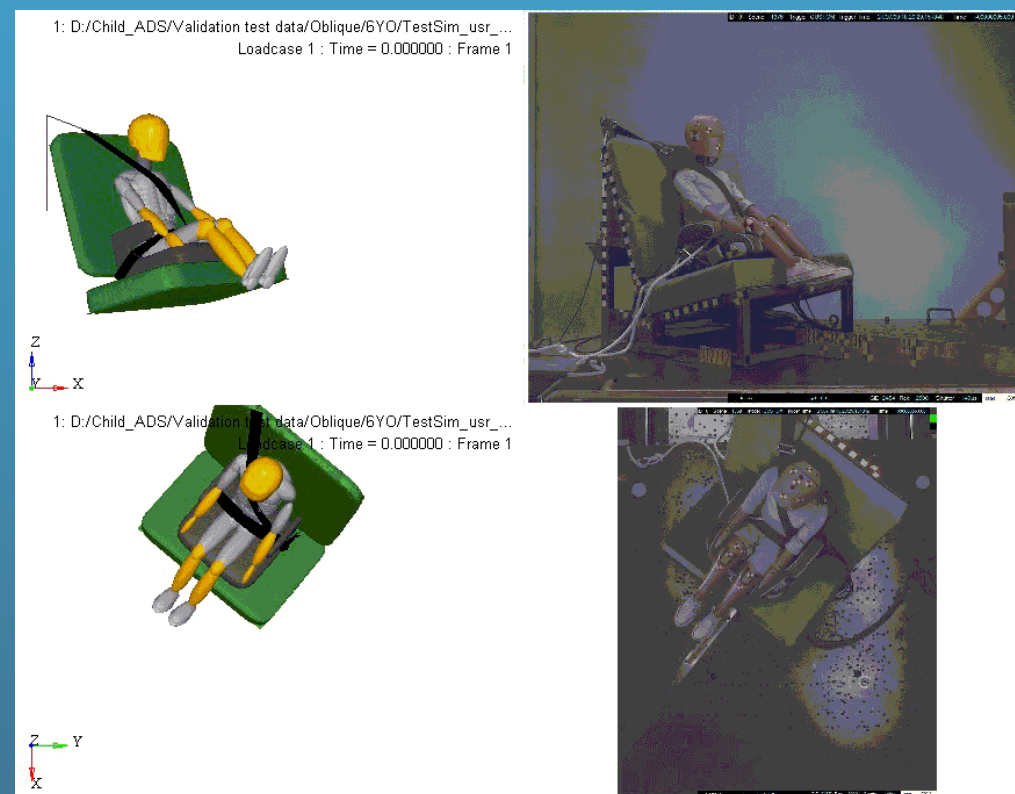

# Research Plan

## ■ Validation tests using 213 buck

- Pulse comparable to FMVSS No 213
  - Front, Frontal Oblique, Far-side, and Rear.
- Seating Environment
  - Frontal 213 buck proposed in frontal NPRM
  - Dodge Caravan vehicle seat for rear impacts

## ■ Simulation Plan

- Compare the responses of younger (1YO – 3YO) occupants in harnessed CRS in conventional vs. unconventional seating environments.
- Compare the responses of older (6YO – 10YO) occupants who use boosters or the vehicle seat in conventional vs. unconventional seating environments.

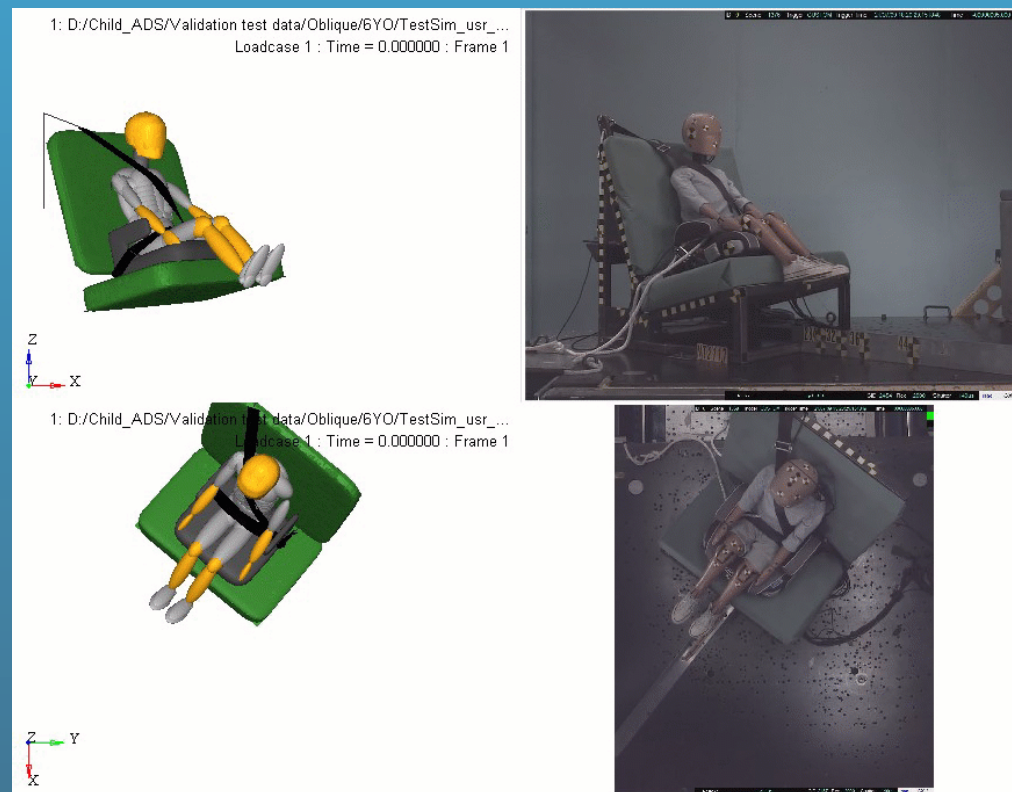



# Research Plan

## ■ Validation tests using 213 buck

- Pulse comparable to FMVSS No 213
  - Front, Frontal Oblique, Far-side, and Rear.
- Seating Environment
  - Frontal 213 buck proposed in frontal NPRM
  - Dodge Caravan vehicle seat for rear impacts

## ■ Simulation Plan

- Compare the responses of younger (1YO – 3YO) occupants in harnessed CRS in conventional vs. unconventional seating environments.
- Compare the responses of older (6YO – 10YO) occupants who use boosters or the vehicle seat in conventional vs. unconventional seating environments.

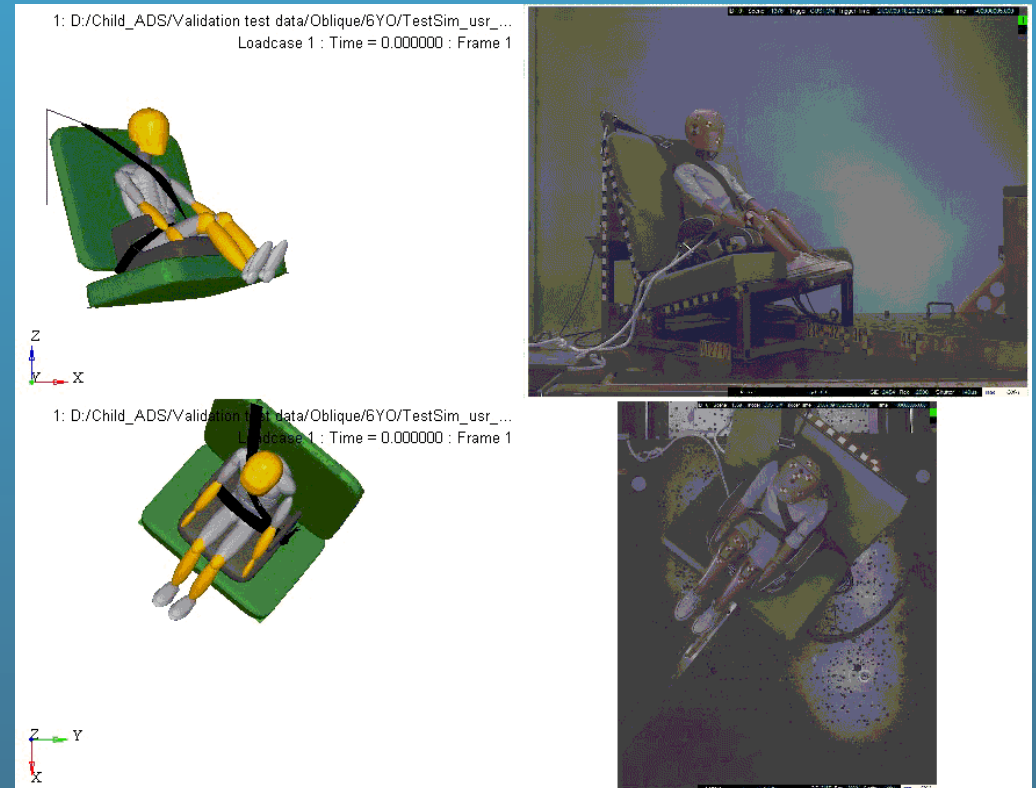

# Thank you for your time and attention

Dan Parent:

[dan.parent@dot.gov](mailto:dan.parent@dot.gov)

Jason Stammen:

[jason.stammen@dot.gov](mailto:jason.stammen@dot.gov)

Ian Hall:

[ian.hall@dot.gov](mailto:ian.hall@dot.gov)