

VIN marking area for EV6 model

- 1. Hood**
- 2. Tail Gate**
- 3. Front Fender (LH/RH)**
- 4. Front Door (LH/RH)**
- 5. Rear Door (LH/RH)**
- 6. Side Outer Panel (LH/RH)**
- 7. Front Bumper**
- 8. Rear Bumper**
- 9. Motor & Decelerator (FR/RR)**



Hood

TARGET AREA FOR
REPLACEMENT PART

TARGET AREA FOR
ORIGINALLY EQUIPPED PART

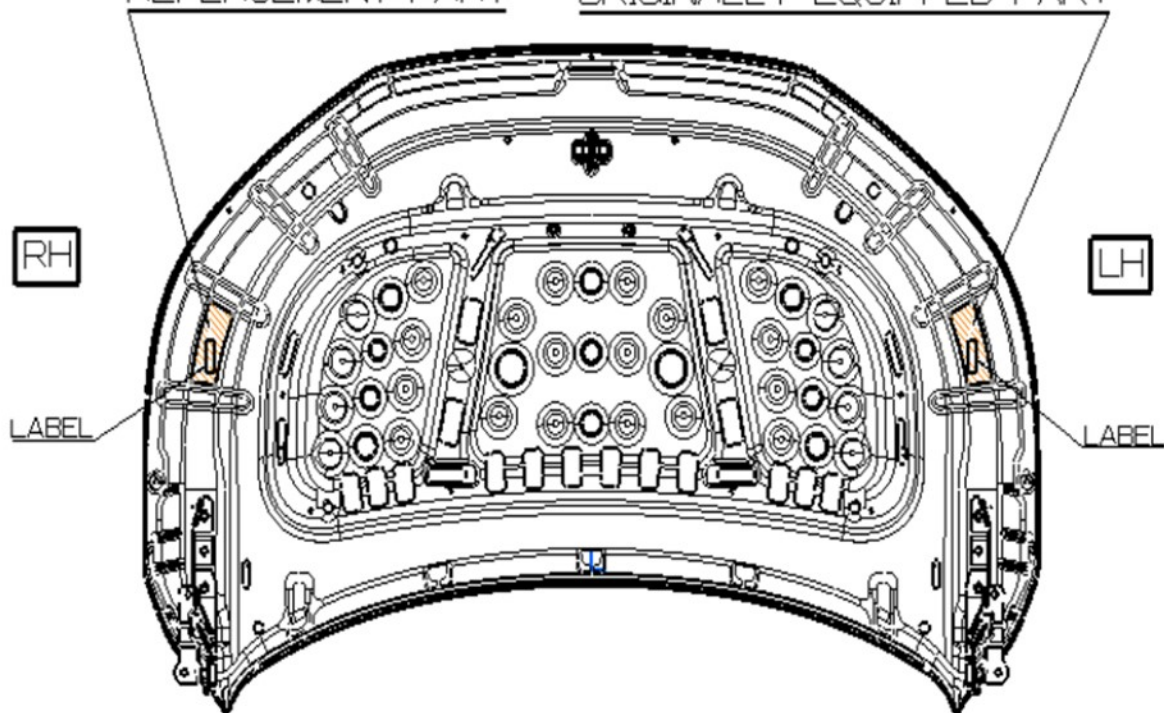

Tail Gate

TARGET AREA FOR
REPLACEMENT PART

TARGET AREA FOR
ORIGINALLY EQUIPPED PART

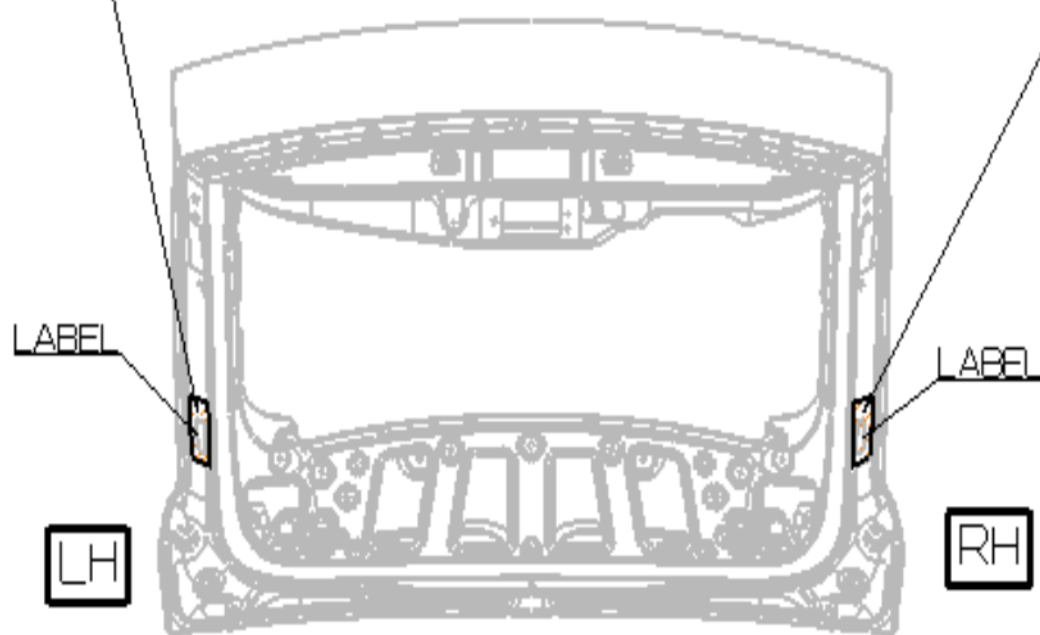

Front Fender (LH/RH)

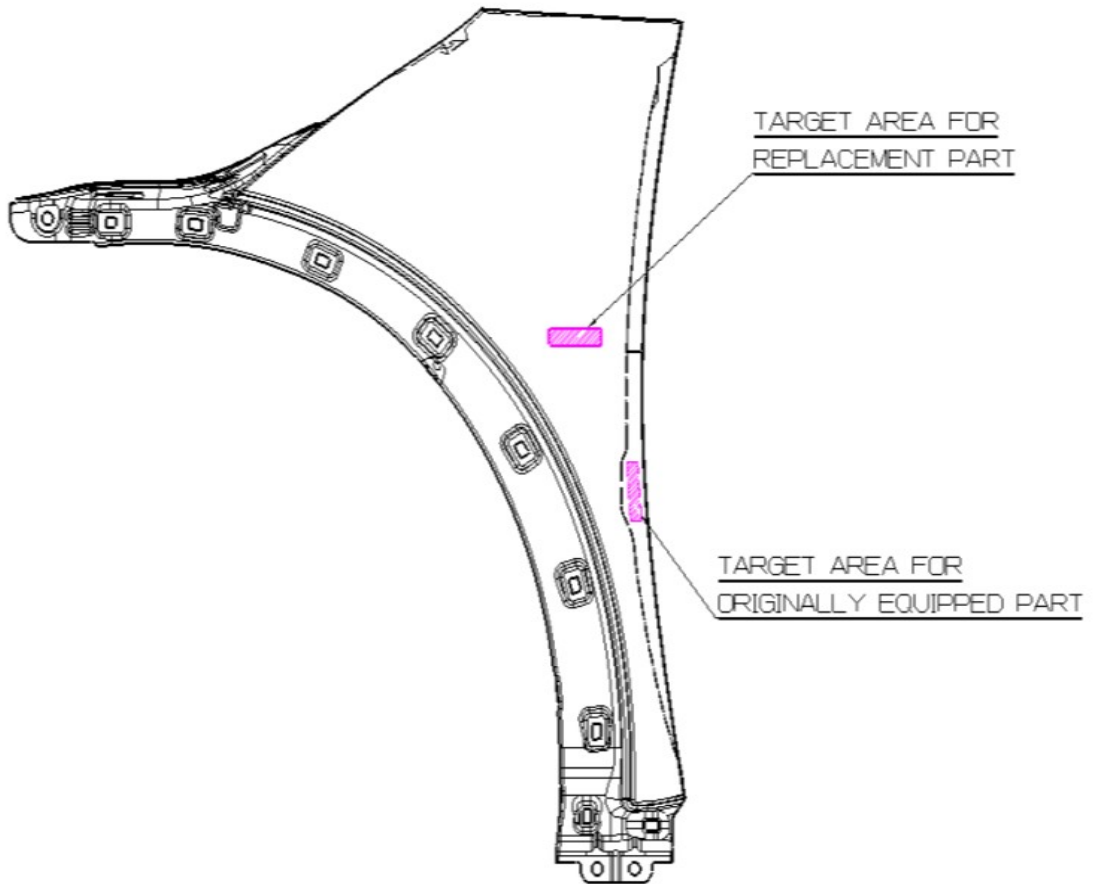

PNL-FENDER, LH/RH

Front Door (LH/RH)

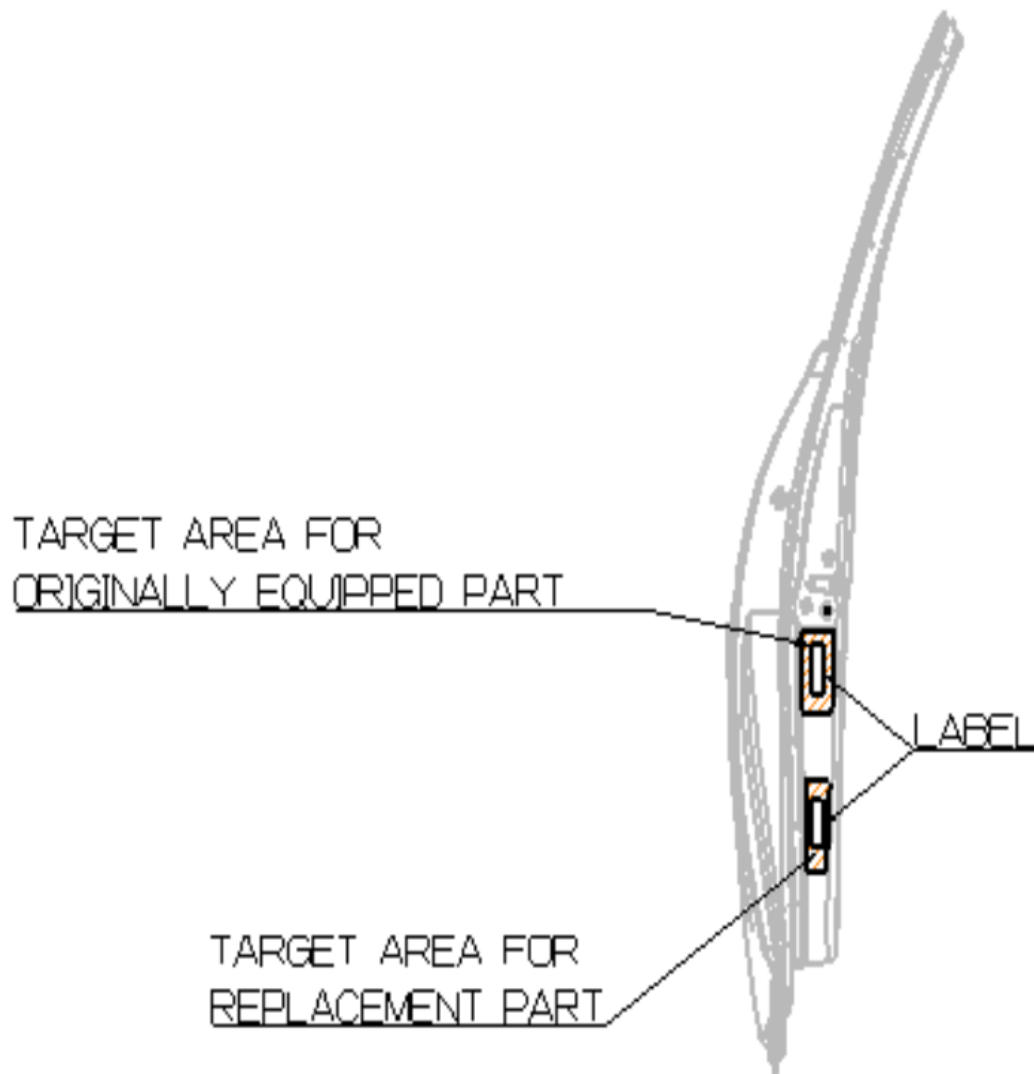

Rear Door (LH/RH)

TARGET AREA FOR
ORIGINALLY EQUIPPED PART

TARGET AREA FOR
REPLACEMENT PART

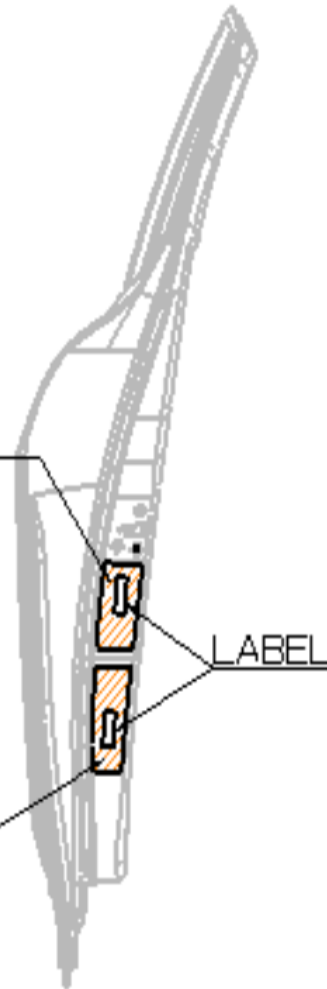

Side Outer Panel (LH/RH)

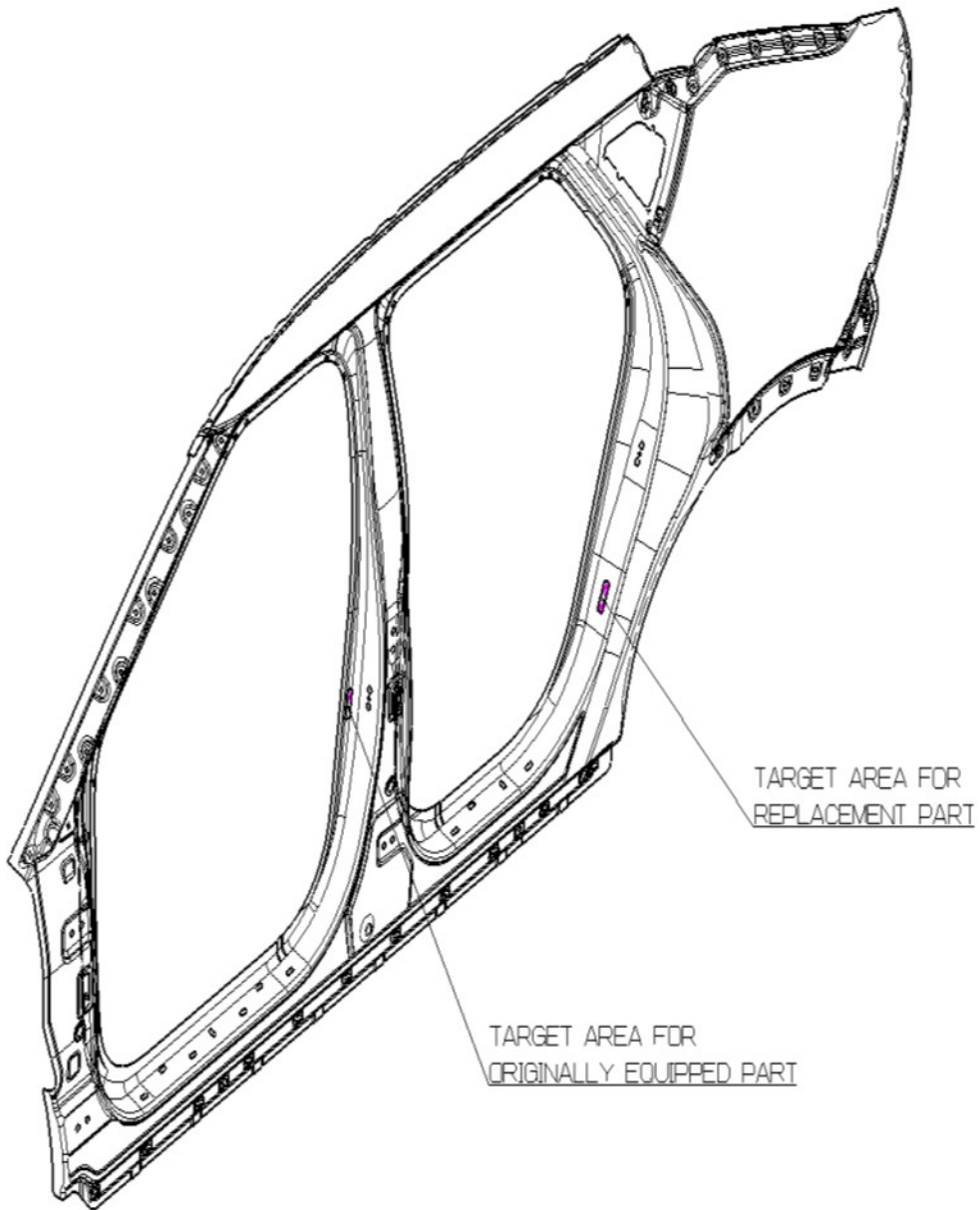

PNL-SIDE OTR, LH/RH

Front Bumper

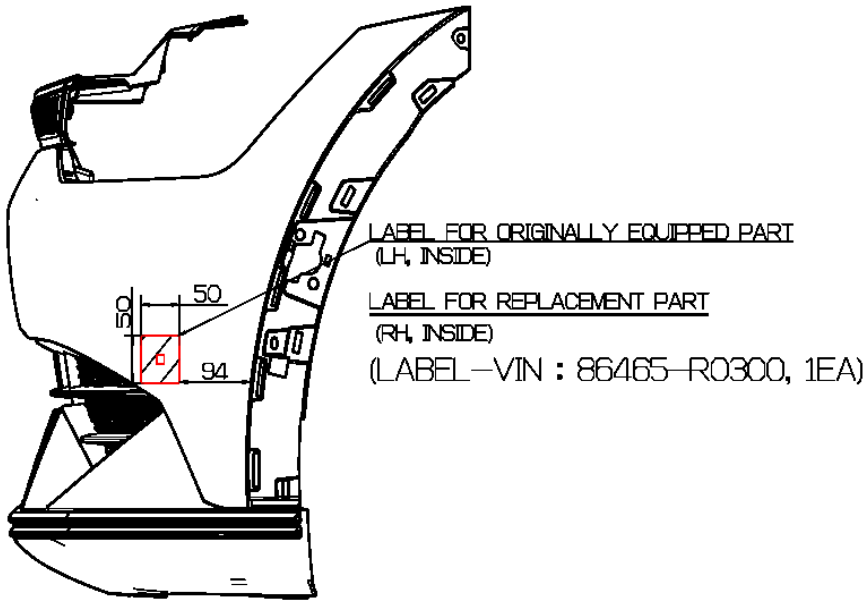

FR BUMPER ASSY (STD)

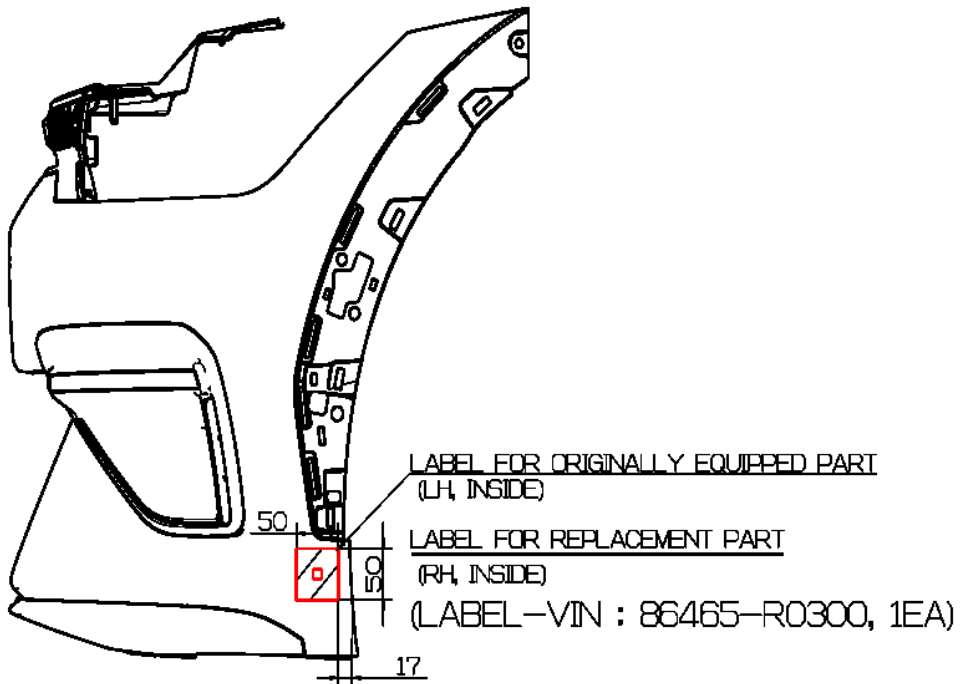

FR BUMPER ASSY (GT-LINE)

Rear Bumper

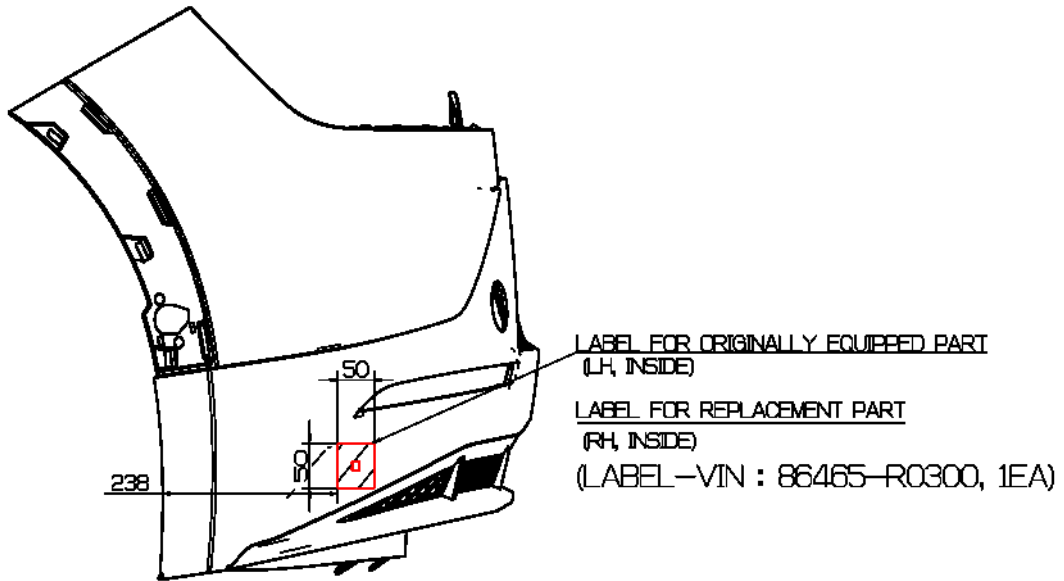

RR BUMPER ASSY (STD)

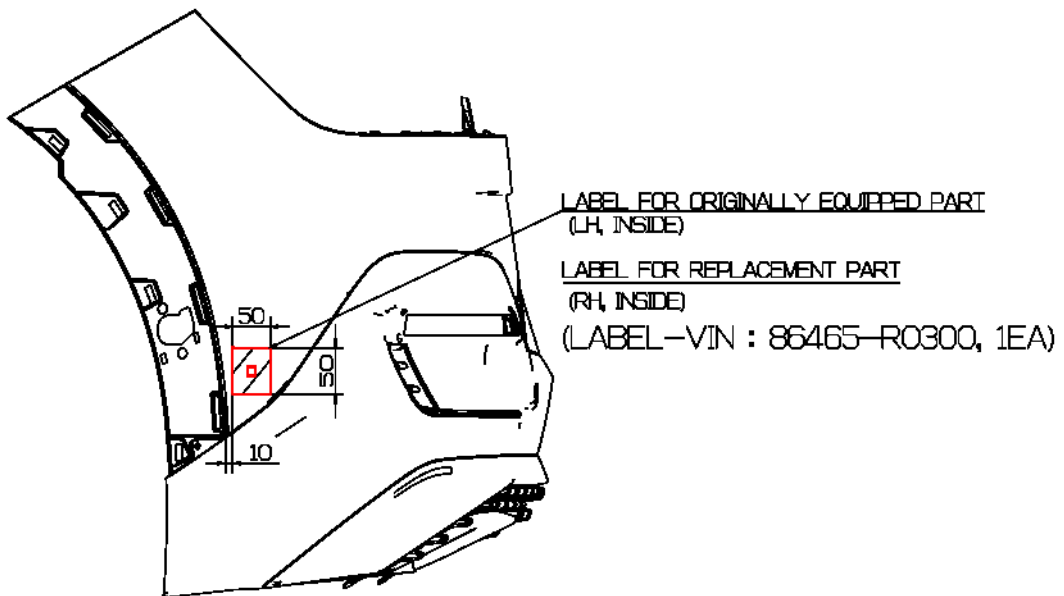

RR BUMPER ASSY (GT-LINE)

CV Motor (FR)

TARGET AREA FOR
ORIGINALLY EQUIPPED
PART

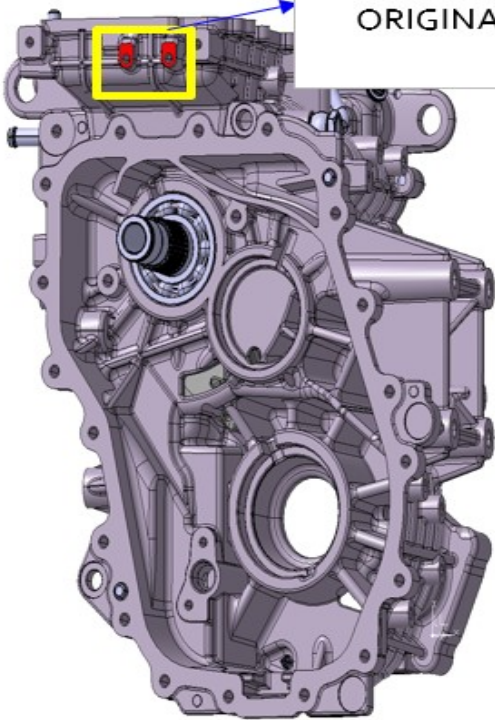

TARGET AREA FOR
REPLACEMENT
PART

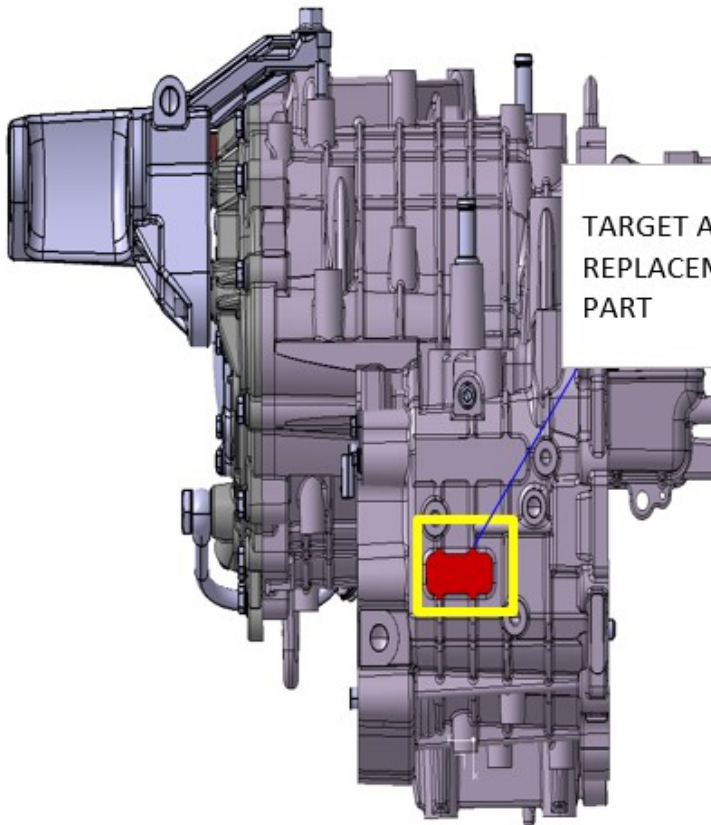

CV Motor (RR)

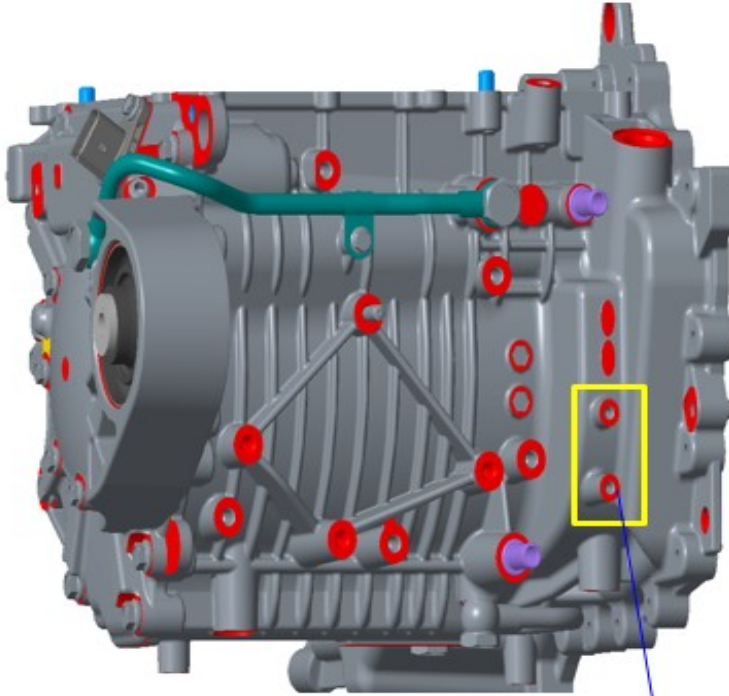

TARGET AREA FOR
ORIGINALLY
EQUIPPED PART

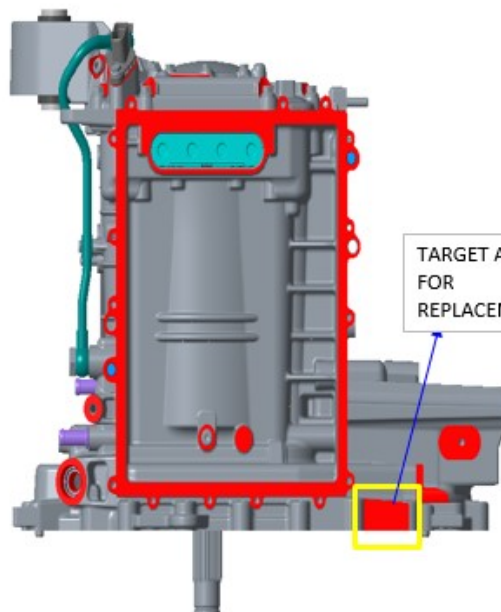

TARGET AREA
FOR
REPLACEMENT