

# **MOTHERS AGAINST DRUNK DRIVING**

## **Updated Report: Advanced Drunk Driving Prevention Technologies**

**Driving performance monitoring, driver monitoring and passive alcohol detection technology can eliminate drunk, drugged, and other forms of impaired driving.**

**NO MORE VICTIMS:  
Technologies to eliminate drunk driving, and other forms of driver impairment, are ready for the road**

**May 12, 2021  
Edition Two**

**DOT Docket No. NHTSA-2020-0102**  
Docket Management Facility  
U.S. Department of Transportation West Building  
Ground Floor Room W12-140  
1200 New Jersey Avenue, S.E. Washington, D.C. 20590-0001  
Filed via [www.regulations.gov](http://www.regulations.gov)  
**Impaired Driving Technologies Request for Information**  
**85 Federal Register 71987, November 12, 2020**

## Letter from MADD National President Alex Otte

In 2019, 10,142 people were killed in alcohol-related traffic crashes, and hundreds of thousands more were seriously injured. According to preliminary data from the National Highway Traffic Safety Administration (NHTSA), for the first nine months of 2020, traffic fatalities increased by 5 percent even though the number of vehicle miles traveled decreased by 15 percent. (NHTSA, 2020). This tragic increase in roadway fatalities is one of the biggest hikes in a generation, and it shows the fight against impaired driving is far from over.

On January 11, 2021, Mothers Against Drunk Driving (MADD) submitted information on 187 impaired driving vehicle safety technologies as a result of a Request for Information (RFI) by NHTSA. The request from NHTSA was for information from these four areas:

- (1) technologies that can monitor driver action, activity, behavior or responses, such as vehicle movements during lane keeping, erratic control, or sudden maneuvers;
- (2) technologies that can directly monitor driver impairment (e.g., breath, touch-based detection through skin);
- (3) technologies that can monitor a driver's physical characteristics, such as eye tracking or other measures of impairment;
- (4) technologies or sensors that directly measure a driver's physiological indicators that are already linked to forms of impaired driving (e.g., BAC level).

In the original RFI response, MADD submitted information on only categories two through four. This new document is an update to the RFI submitted in January. In this document, MADD provides a new introduction on how technologies to eliminate drunk driving and other forms of driver impairment are ready for the road. MADD also reviews the feasibility for these technologies to stop drunk driving and examine how they can work in tandem, as a system.

This updated report also includes information related to lane keeping and attention assist, and reorganizes the previous RFI response in an easier to read format (broken down by Automakers, Tier 1 Suppliers, Tier II Suppliers, or other). Additionally, MADD provides information on new technologies that have been made public in the last three months.

**In total, this updated report details 241 examples of technology that NHTSA should consider as part of a rulemaking to prevent impaired driving.** Numerous technologies to correct dangerous and deadly driving behaviors are available today, and are now an option on almost all new vehicles. Driving performance monitoring systems are critical to the elimination of impaired driving and will likely be used in tandem with other driver monitoring systems, and potentially (but not limited to) breath or touch-based passive alcohol detection technology.

Sincerely,



Alex Otte  
MADD National President

## **Table of Contents**

**Page 4: Technologies to eliminate drunk driving, and other forms of driver impairment**

**Page 5: Driving performance monitoring systems: lane departure warning and attention assist**

**Page 8: Driver monitoring systems: face, eyes or other**

**Page 14: Passive alcohol sensors**

**Page 16: Chart of technology developed by automakers and suppliers**

**Page 17 to 93: Automakers' driving performance monitoring, driver monitoring and passive alcohol sensing safety technologies**

**Page 94 to 130: Tier 1 suppliers driving performance monitoring, driver monitoring and passive alcohol sensing technologies**

**Page 131 to 151: Tier 2 suppliers and other driving performance monitoring, driver monitoring and passive alcohol sensing technologies**

## Introduction: Technologies to eliminate drunk driving, and other forms of driver impairment, are ready for the road

### Breakdown of technologies described in the report

Provider	Driving Performance Monitoring (e.g., Lane Assist, Attention Monitor)	Driver Monitoring (e.g., head and eye)	Passive Breath or Touch Alcohol Detection	Total
Automakers	74	41	15	130
Tier 1 Suppliers		46	14	60
Tier 2, Other Suppliers	3	35	13	51
<b>Total</b>	<b>77</b>	<b>122</b>	<b>42</b>	<b>241</b>

There are 241 technologies described in this document, which are detailed beginning on page 17. First, it is important to look at three types of technology:

- 1) Driving performance monitoring systems: lane departure warning and attention assist. These technologies are often referred to as advanced driver assistance systems (ADAS).
- 2) Driver monitoring systems: monitoring of the driver's head and eyes that typically uses a camera or other sensors to determine the driver's state.
- 3) Passive alcohol detection sensors: touch or breath based.

**Each type of technology can significantly reduce or even stop drunk driving. Working together as a system, these technologies will eliminate drunk driving, drugged-driving, and other types of driver impairment, once and for all.**

For each technology, this report answers the following questions:

- Which companies have the technology?
- What can this technology do?
- Is the technology production-ready?
- What is the cost?
- How can this technology help stop drunk and drugged driving now?

Finally, this report concludes by showing how driving performance monitoring systems, driver monitoring and passive alcohol detection can and will be very effective in stopping drunk driving.

# Driving performance monitoring systems: Available today to help prevent drunk driving crashes

This report details 77 lane departure warning, lane keeping assist or attention assist monitoring systems. These technologies are often referred to as advanced driver assistance systems (ADAS). According to the Insurance Institute for Highway Safety (IIHS), other ADAS systems include: forward collision warning, forward collision warning plus autobrake, blind spot detection and rear automatic braking. IIHS compared rates of police-reported crashes and insurance claims for vehicles with and without these technologies, and found that lower crash rates are a clear benefit of these systems.<sup>1</sup>

Manufacturers building cars with lane departure warning systems or attention monitors also provide additional ADAS features. *Consumer Reports* provides a helpful overview of these technologies.<sup>2,3</sup> Currently in the United States, ADAS systems are typically sold as an option, and, if a consumer purchases the option, he or she can turn the feature off. This negates the safety benefits of these features.

**ADAS turned off in impaired driving crashes.** MADD has been made aware of cases in which it was determined an impaired driver turned off the ADAS features.

**How ADAS (lane change, attention monitor) can help determine and control impaired driving behavior?** As impaired drivers may not be fully aware of their surroundings, these systems can correct erratic driving behavior. Impaired drivers tend to be inattentive and weave and zig-zag across the road, and these features would provide corrective action.

**Could ADAS systems be tested to determine impaired and erratic driving behavior and take corrective action?** Automakers and suppliers who developed ADAS have tested the technology before making it available to consumers. During testing, automakers and suppliers developed data points to determine when these systems must engage.

## NEXT STEPS: ADAS

**MADD urges Congress to enact the HALT/RIDE Act (HR 2138/S 1331). The legislation requires NHTSA to conduct a rulemaking on impaired driving prevention technology. As part of the rulemaking process, NHTSA will test and standardize effective ADAS - and mandate the technology on all new vehicles.**

---

<sup>1</sup> "Real-world benefits of crash avoidance technologies," IIHS. <https://www.iihs.org/media/259e5bbd-f859-42a7-bd54-3888f7a2d3ef/shuYZQ/Topics/ADVANCED%20DRIVER%20ASSISTANCE/IIHS-real-world-CA-benefits.pdf>

<sup>2</sup> "Guide to Cars With Advanced Safety Systems," *Consumer Reports*. March 8, 2021. <https://www.consumerreports.org/car-safety/cars-with-advanced-safety-systems/>

<sup>3</sup> "Active Driving Assistance systems," *Consumer Reports*. November 2020. <https://data.consumerreports.org/wp-content/uploads/2020/11/consumer-reports-active-driving-assistance-systems-november-16-2020.pdf>

**ADAS should be standard on all new vehicles.** ADAS holds great promise to help reduce or stop impaired driving, but the current optional roll out of this technology holds little promise. ADAS should be a standard feature on all new vehicles, and should be further tested on impaired drivers now in order to determine data points for corrective action.

Many of today's new vehicles already have the hardware and software for ADAS installed. Implementing ADAS-based impaired driving prevention systems could have an immediate, life-saving impact on our nation's roads. And it can be done cost-effectively.

### **Overview of companies that have these technologies**

There are 77 technologies covered in this section on lane change or attention monitoring. Here we review specifically automakers and not other suppliers. And, as previously noted, many automakers have an array of other ADAS systems that are not included in this section. The chart in this section breaks up our review of these ADAS technologies into three sections:

- 1) Lane change warning/lane change assist
- 2) Attention monitoring
- 3) Emergency slow down or stop of vehicle

**Lane change warning/lane change assist.** These technologies alert the driver with vibrations, a display in the instrument cluster or with an audio warning of the lane change and provide corrective steering. Some lane change systems will only alert the driver and not take action; others will take action to center the driver. These systems use cameras to monitor for lane markings.

**Attention monitoring.** These technologies monitor and assess driver behavior. The system uses input from the steering angle sensors and monitors the vehicle driver to gauge awareness. If the driver is determined inattentive, the system will display visual or audio messages to take a break. Some systems can display a person's level of attention in the instrument cluster via a bar system or color system.

**Emergency slow down or stop of a vehicle.** Daimler, Seat and other automakers have developed and are developing technologies that can brake or slow the vehicle if the driver is inattentive due to a lack of steering wheel movement, braking or response to visual or audio warnings. These systems can be used, for example, in a medical emergency. Ultimately these technologies demonstrate that, if necessary and according to future standards set by NHTSA, a vehicle can take corrective, life-saving action when driven erratically.

The following chart references where in this document the technology can be found.

## Driving performance monitoring systems: lane departure warning and attention assist

Provider	Lane change warning/assist	Attention Monitor	Emergency stop or slow down	RFI Number
Acura	Yes	Yes		1, 2
Alfa Romeo	Yes	Yes		3, 4
Audi	Yes	Yes		5, 6
Bentley	Yes			7
BMW	Yes			9, 10
Buick	Yes			12, 13
Cadillac	Yes			14
Chevrolet	Yes			17
Chrysler	Yes			18
Dodge	Yes			19
Daimler AG	Yes	Yes	Yes	21, 22, 23
Fiat	Yes	Yes		25, 26
Ford	Yes	Yes		27, 28
FUSO	Yes			37
Genesis	Yes	Yes		39, 40
GMC	Yes			47
Honda	Yes	Yes		48, 49, 50
Hyundai	Yes	Yes		59, 60
Infiniti	Yes			66
Jaguar	Yes	Yes		67, 68, 69
Land Rover	Yes	Yes		72, 73
Jeep	Yes			74, 75
Kia	Yes	Yes		76, 77, 78
Lexus	Yes	Yes		79, 80, 81
Lincoln	Yes			84
Mazda	Yes	Yes		85, 86, 87
Mitsubishi	Yes	Yes		88, 89
Nissan	Yes	Yes		90, 91, 92
Porsche	Yes			95
Groupe PSA	Yes			96
Seat	Yes		Yes	97, 98, 99
Subaru	Yes			101
Tesla	Yes	Yes	Yes	103, 104, 105
Toyota	Yes			107, 108, 109
Volkswagen	Yes	Yes		120, 121, 122
Lime Scooters			Yes	215
Mobile Eye	Yes			217
Nauto, Inc.	Yes			218

## **Many automakers already include driving performance monitoring systems like lane departure warning and attention assist**

These technologies are production-ready and are available on most new vehicles. Additionally, automakers have the capability to engage emergency stop and/or slowing of a vehicle.

The cost of lane change assist and attention monitoring is minimal, as the hardware and software for this technology is already available in most new cars - and mass produced. The cost to mandate ADAS technology as a way to help stop impaired driving is minimal compared to the \$44 billion annual cost of drunk driving crashes in United States.<sup>4</sup> That is in addition to the human toll on victims and their families. Costs to further test ADAS to determine how systems engage when the driver is impaired are exponentially lower than the consequences of maintaining the status quo.

**How can this technology help stop drunk and drugged driving now?** MADD believes that regulators and automakers should determine what parameters are associated with impaired driving that trigger ADAS engagement. When realized, the impact on traffic crashes will be historic.

The enormous, life-saving potential of ADAS can only be realized when it becomes standard on all vehicles, and activated at all times.

## **Driver Monitoring (e.g. face or eyes): Available today to help prevent drunk driving crashes**

### **Indicators for alcohol impairment are very telling through the eyes and face.**

When exploring technology that focuses on visual signs of impairment in the face, it is important to note how law enforcement also looks for these signs when testing a suspected drunk driver. Standard Field Sobriety Test (SFST), Advanced Roadside Impaired Driving Enforcement (ARIDE), Drug Recognition Expert (DRE) and other tests law enforcement use look specifically at the movement and characteristics of a person's eyes for alcohol and other drug-impairment.

Drugs and alcohol (depressants) affect a person's eye movement and other body characteristics. Driver monitoring systems that currently exist can determine drowsy and distracted driving and can also, in many instances, detect substance impairment.

---

<sup>4</sup> "Alcohol Impaired Driving," NHTSA. December 2019.  
<https://crashstats.nhtsa.dot.gov/Api/Public/ViewPublication/812864>



### **Driver monitoring systems: eye, head, and in-cabin driver condition monitoring**

More automakers are offering in-vehicle cabin sensing that measures a person's face, eyes or head for signs of distraction or fatigue. Some of these systems also use the seat and other cabin sensors to determine a driver's state. As these technologies look for signs of fatigue and distraction, they could also be programmed to determine substance impairment. Currently, Volvo is advertising this system as an intoxication detection system.

As noted, eyes and head-based driver monitoring systems also intersect with Autonomous Vehicle technologies. At a Level 3 autonomy, a vehicle needs to have a read on a driver's physical condition.

### **Overview of companies with these technologies**

There are 122 technologies covered in this section on lane change or attention monitoring. We look at automakers, Tier 1 suppliers, Tier 2 suppliers and other suppliers with this technology. The chart in this section breaks up our review of eye and head-based driver monitoring into the following five sections:

- 1) Eye, head or face camera-based
- 2) Seat or wheel biometrics that can monitor the heart or brain activity
- 3) Other cabin sensors (this is typically a combination of all sensors)
- 4) Autonomous vehicle interaction
- 5) Emergency stop or slow down

**Eye, head, or face camera-based monitoring.** Most in-cabin driver monitoring systems use a camera to determine a driver's physical or emotional state by looking at the person's eyes, face, gaze or head movements. Some automakers are using these systems as a way to unlock a vehicle.

**Seat or wheel biometrics that can monitor the heart or brain activity.** There are systems in development to monitor a person's heart rate. Some also measure brain activity. These systems usually use biometrics in the seat, but some also use a steering wheel.

**Other cabin sensors.** The providers are developing technology that helps with sensing vehicle occupant physical and emotional state.

**Autonomous vehicle interaction.** When autonomous vehicle technologies are at a Level 3 autonomy, a vehicle needs to have a read on a driver's physical condition. Automakers and their suppliers are developing in-cabin driver monitoring that interacts with the operation of autonomous vehicles.

**Emergency stop or slow down.** As in the first section on driver monitoring systems like lane departure warning and attention assist, these systems can also stop a vehicle or slow down the vehicle depending on the condition of the driver. Artificial Intelligence, hardware and other software play a role in the development of this driver monitoring technology.

The following chart references where in this document each technology can be found.

## Automakers: Driver monitoring (e.g. face or eyes)

Automaker	Eye, head or face camera	Seat or wheel biometrics	Other cabin sensors	Autonomous vehicle interaction	Emergency stop or slow down	RFI Number
Bentley	Yes	Yes	Yes	Yes		8
BMW	Yes					11
Cadillac	Yes					15, 16
DS Automobiles	Yes					20
Daimler AG	Yes					24
Ford	Yes	Yes	Yes	Yes	Yes	29-33
FUSO	Yes					38
Genesis						41
GM	Yes			Yes		43
Honda	Yes	Yes	Yes	Yes		51-55
Hyundai	Yes	Yes	Yes	Yes	Yes	61-64
Jaguar Land Rover	Yes	Yes		Yes		70, 71
Lexus	Yes		Yes	Yes	Yes	82, 83
Nissan	Yes			Yes		93, 94
Seat	Yes					100
Subaru	Yes					102
Tesla	Yes					106
Toyota	Yes	Yes	Yes	Yes	Yes	110-113, 116
Volkswagen	Yes					123
Volvo	Yes					124, 125

### Tier 1 Suppliers: Driver monitoring (e.g. face or eyes)

Tier 1 Suppliers	Eye, head or face camera	Seat or wheel biometrics	Other cabin sensors	Autonomous vehicle interaction	Emergency stop or slow down	RFI Number
Adient		Yes				131
Aisin Seiki Co.	Yes					132
Aptiv	Yes					133
Autoliv	Yes					134
Bosch	Yes			Yes		136, 137
Continental	Yes	Yes				139, 140
Delphi/Borgwarner	Yes					142
Denso	Yes	Yes	Yes	Yes	Yes	143-147
Faurecia		Yes	Yes	Yes	Yes	151, 152
Gentex	Yes					154, 155
Grupo Antolin	Yes					157
Hitachi	Yes		Yes			158
Hyundai Mobis	Yes	Yes	Yes	Yes		160-163
Infineon Technologies			Yes			164
Jabil	Yes					165
Joyson Safety	Yes					166
Lear		Yes				168, 169
Leopold Kostal	Yes			Yes		170
Magna	Yes					173, 174
Mitsubishi Electric	Yes					175
Panasonic	Yes					176
Samsung	Yes	Yes				178
Sony			Yes			179
Sumitomo Riko		Yes				180
Toyoda Gosei	Yes					181
Toyota Boshoku	Yes					182, 183
TS Tech		Yes				184
Valeo	Yes					185
Visteon Corp	Yes					187
Yanfeng	Yes					188
Yazaki			Yes			189
ZF Friedrichshafen AG				Yes		190

## Tier 2, Other Suppliers: Driver monitoring (e.g. face or eyes)

Tier 2, Other Suppliers	Eye, head or face camera	Seat or wheel biometrics	Other cabin sensors	Autonomous vehicle interaction	Emergency stop or slow down	RFI Number
Abto	Yes					191
ADAM	Yes					192
Affectiva	Yes					193
Ambarella	Yes					194
American Vehicular Sciences LLC			Yes			195
AMS	Yes			Yes		196
Autocruis Technology Co			Yes			198
Baidu Apollo	Yes					202
CardioID		Yes				203
Cipia (formerly EyeSight)	Yes					204
DTS Autosense			Yes	Yes		206
Eyegaze	Yes					208
Gaze Sense	Yes					209
FutureWei Technologies Inc			Yes			210
Harman	Yes			Yes		211
Joynext			Yes			214
Melexis	Yes					216
NVIDIA Corporation	Yes					219
NXP	Yes					220
Optalert	Yes					221
Pioneer			Yes			222
Plessey Semiconductors		Yes				223
PrevcitDrugs	Yes					224
Primax	Yes					225
Seeing Machines	Yes					226
SpeedGauge			Yes			229
Sight hound	Yes					230
Smart Eye	Yes					231
SRI			Yes			233
ST			Yes			234
Tata Elxsi	Yes					235
Veoneer		Yes				238
Wipro	Yes					239
Xandar Kardian		Yes				240
Xperi			Yes			241

## **NEXT STEPS: Driver monitoring (e.g. face or eyes)**

Most camera-based driver monitoring systems that determine the physical or emotional state of the driver are ready for production or already in production. In 2019, Volvo became the first automaker to advertise eye-gaze camera technology as a way to determine driver intoxication. A demonstration video currently on Volvo's website shows how the eye-gaze technology works, and how the vehicle can take corrective action<sup>5</sup>.

**MADD urges Congress to enact the HALT/RIDE Act (HR 2138/S 1331). The legislation requires NHTSA to conduct a rulemaking on impaired driving prevention technology. As part of the rulemaking process, NHTSA will test and standardize effective driver impairment monitoring systems - and mandate the technology on all new vehicles.**

---

<sup>5</sup> <https://www.media.volvocars.com/global/en-gb/media/videos/250162/in-car-cameras-and-intervention-against-intoxication-distraction-animation1>

## Passive Alcohol Detection: Available today to help prevent drunk driving crashes

Technologies under development can work together with driver monitoring systems to determine a driver’s alcohol-impairment level. According to the Insurance Institute for Highway Safety, if all cars were equipped with technology that could stop a drunk driver from operating a vehicle, more than 9,400 lives could be saved annually. This section will look at 42 passive alcohol technologies in development by automakers and their suppliers. Passive alcohol touch or breath sensors combined with driver monitoring would make impaired driving a thing of the past, but only if this technology is a standard feature on all new vehicles. The review of the 42 technologies in the chart are divided into four categories: Automakers, Tier 1 and Tier 2 suppliers are developing the following technologies:

- 1) Touch
- 2) Breath
- 3) Voice
- 4) Autonomous vehicle interaction

Provider	Touch	Breath	Voice	Autonomous vehicle interaction	RFI Number
Ford	Yes		Yes	Yes	34-36
GM	Yes	Yes		Yes	42, 44, 45, 46
Honda	Yes		Yes	Yes	56-58
Hyundai	Yes				65
Toyota	Yes	Yes	Yes	Yes	114, 115, 117, 119
Autoliv	Yes				135
Bosch	Yes				138
Continental Automotive	Yes				141
Denso Corp	Yes	Yes			148-150
Faurcia		Yes			153
Gentex		Yes			156
Hitachi		Yes			159
Joyson Safety	Yes	Yes		Yes	167
LG Electronics Inc	Yes				171
LG Innotek Co Ltd	Yes				172
Panasonic	Yes				177
Valeo	Yes				186
Apple		Yes			197
Automotive Coalition for Traffic Safety	Yes				199-201
Delta Tooling	Yes				207
HID Global	Yes				212-213
Senseair		Yes			227-228
Sober steering	Yes				232
TruTouch	Yes				236
Thunder Power	Yes				237

## **NEXT STEPS: Passive alcohol detection**

Automakers, Tier 1 and Tier 2 suppliers, and the federal government have put some resources into the development of passive alcohol detection sensors. This technology can help stop drunk driving, but only if it is made standard on all new vehicles.

**MADD urges Congress to enact the HALT/RIDE Act (HR 2138/S 1331). The legislation requires NHTSA to conduct a rulemaking on impaired driving prevention technology. As part of the rulemaking process, NHTSA will test and standardize effective passive alcohol detection technology - and mandate the technology on all new vehicles.**

If passive alcohol sensors are standard, the cost will be minimal to both manufacturer and consumer. And the cost of passive alcohol detection technology is minimal compared to the \$44 billion annual cost of drunk driving crashes in United States.<sup>6</sup> If optional, the enormous safety benefits of passive alcohol technology will not be realized.

Safety must not be an option.

## **Conclusion**

The auto industry has been in the midst of a technological revolution for more than a decade, with new, incredible advancements routinely announced. Billions of dollars invested in electric and autonomous vehicles have led to the creation of supercomputers on wheels. Some cars are even being built without steering wheels. Current driving performance monitoring systems and driver monitoring systems are passive and unobtrusive to attentive and sober drivers. Additionally, Artificial Intelligence and the multiple sensors that go along with current driver monitoring systems can create a system of redundancy.

Technology to eliminate drunk driving and drugged driving is available. With ADAS systems, driving performance monitoring, driver monitoring and passive alcohol sensors, and passage of the bipartisan HALT Act in the House, and the bipartisan RIDE Act in the Senate, the time to eliminate drunk and drugged driving is now.

---

<sup>6</sup> "Alcohol Impaired Driving," NHTSA. December 2019.  
<https://crashstats.nhtsa.dot.gov/Api/Public/ViewPublication/812864>

## Companies that developed or are developing technologies for driving performance monitoring, driver monitoring and passive in-vehicle alcohol detection



**MADD believes these three technologies together could eliminate drunk, drugged and other forms of impaired driving IF made standard on all new vehicles.**



## Automakers Driving Performance Monitoring, Driver Monitoring and Passive Alcohol Detection Safety Technologies

There are over 130 systems developed or in development from automakers relating to: driving performance monitoring, driver monitoring, and passive alcohol detection. This section will go through these technologies.

Automakers	Driving Performance Monitoring (e.g., Lane Assist, attention monitor)	Driver Monitoring(e.g., eyes, head)	Passive Breath or Touch Alcohol Detection	Total
Acura	2			2
Alfa Romero	2			2
Audi	2			2
Bentley	1	1		2
BMW	2	1		3
Buick	2			2
Cadillac	1	2		3
Chevrolet	1			1
Chrysler	1			1
Dodge	1			1
DS Automobiles		1		1
Daimler	3	1		4
Fiat	2			2
Ford	2	5	3	10
Fuso	1	1		2
Genesis	2	1		3
GM		1	4	5
GMC	1			1
Honda	3	5	3	11
Hyundai	2	4	1	7
Infiniti	1			1
Jaguar	3			3
LandRover	2			2
Jaguar/Land Rover		2		2
Jeep	2			2
Kia	3			3
Lexus	3	2		5
Lincoln	1			1
Mazda	3			3
Mitsubishi	2			2
Nissan	3	2		5
Porsche	1			1
Groupe PSA	1			1
Seat	3	1		4
Subaru	1	1		2
Tesla	3	1		4
Toyota	3	6	4	13
Volkswagen	3	1		4
Volvo	5	2		7
<b>Total</b>	<b>74</b>	<b>41</b>	<b>15</b>	<b>130</b>

## 1. Acura Lane Keeping Assist System (LKAS)

Acura states “If the vehicle begins moving out of its detected lane and the turn signals aren’t activated, alert beeps sound and the Lane Departure Warning appears on the Multi-Information Display, prompting the driver to steer back into the detected lane. Acura models with the Lane Keeping Assist System will automatically apply corrective steering to center you in the detected lane<sup>7</sup>.”

### More Information

- Video from Acura: <https://youtu.be/2vYF9VwO2Gk>

## 2. Acura Driver Awareness Monitor

Acura states “The 2021 TLX also includes a new Driver Awareness Monitor, which continually monitors and assesses driver behavior behind the wheel. Using input from the steering angle sensor to measure both the frequency and severity of the driver's steering inputs to gauge awareness, the system issues a warning to take a break if it determines the driver is becoming inattentive.<sup>8</sup>”

This was announced in 2020 as available on new vehicles. But it is unclear if this is an option yet.

## 3. Alfa Romeo Lane Keeping Assist

The technology is described as “Lane Keeping Assist is an intelligent system used to support the driver to stay on the right course, keeping the vehicle within the lane. Thanks to the use of a camera mounted on the upper area of the windshield the Lane Keeping Assist system detects in real time the limits of the lane. This advanced safety system guarantees the right driving path, giving visual and acoustic alerts and a vibration of the steering wheel every time the car inadvertently starts to stray out of the lane.”<sup>9</sup>

There are limitations to the system as it only operates when, “Vehicle’s speed is between 37 and 111 mph, Visibility is good, roads are straight and with wide bends, and there is safe distance from the vehicle in front.”

### More Information

- Alfa Romeo Lane Keeping Assist Video: [https://youtu.be/toI3ak\\_QFfY](https://youtu.be/toI3ak_QFfY)

---

<sup>7</sup> “Lane Keeping Assist System,” Acura. <https://owners.acura.com/vehicles/information/2021/RDX/features/Lane-Keeping-Assist-System/>

<sup>8</sup> “All-New 2021 TLX Advances Acura’s Commitment to Safety Performance,” Honda. <https://hondanews.com/en-US/releases/release-6c8f365baeb2f83cfe863e5284004fbe-all-new-2021-tlx-advances-acuras-commitment-to-safety-performance>

<sup>9</sup> “Lane Keeping Assist Stay Always on the Right Course,” Alfa Romeo. <https://www.alfaromeo.com/advanced-driver-assistance-systems-adas/lane-keeping-assist#>

## 4. Alfa Romeo Driver Attention Assist

The system is described as "Driver Attention Alert will indicate when your driving patterns seem like you're driving while distracted or drowsy."<sup>10</sup>

The Driver Attention Alert system works in the following:

The driver attention alert system analyzes the following factors to determine whether you are fatigued or driving like you are: Your specific driving style, Lane crossings & how you change lanes, The time you spend behind the wheel at speeds between 40 & 110 mph. If the system detects that you seem to be tired behind the wheel, a symbol with a red cup of coffee and the message "Take a break!" will flash on the instrument cluster display. You will also hear a chime to indicate that the message has appeared.

You can accept the suggestion by hitting the Menu button on the multifunction lever, but the red coffee cup will remain as a smaller icon in the instrument panel until you turn off the ignition. If the suggestion is ignored, the audible alerts will continue.<sup>11</sup>

### More Information

- Alfa Romeo Driver Attention Assist Video: <https://www.youtube.com/watch?v=LQ4CjI2yRDc>

## 5. Audi Active Lane Assist

The technology is described as "Active lane assist can provide steering guidance to help the driver keep the vehicle in the lane. Detecting lane markings, roadside structures and vehicles in adjacent lanes allows the system to make a virtual driving path to help guide the vehicle."<sup>12</sup>



Dramatization of Audi Active Lane Assist (Audi)

### More information:

- Audi Active Lane Assist Video: [https://www.youtube.com/watch?v=8L9fkSV\\_Do4](https://www.youtube.com/watch?v=8L9fkSV_Do4)

<sup>10</sup> "Alfa Romeo Giulia," Alfa Romeo of Arlington. <https://www.alfaromeousaofarlington.com/models/giulia/>.

<sup>11</sup> "How the Alfa Romeo Driver Attention Alert System Keeps You in Check," Ramsey Alfa Romeo. <https://www.alfaromeousaofuppersaddleriver.com/blog/2020/july/23/alfa-romeo-driver-attention-alert.htm>

<sup>12</sup> "Audi pre sense systems," Audi USA. <https://www.audiusa.com/us/web/en/innovation/driver-assistance.html#>

## 6. Audi Attention Assist

The system is described as “Audi Attention Assist uses electronics developed to monitor driver steering input and pedal use to detect the telltale signs of drowsiness and react accordingly. An instrument panel warning is the first ‘wake up call’ and is accompanied by an audible warning.”<sup>13</sup>

## 7. Bentley Lane Assist

The system utilizes a “camera integrated into the vehicle, the Lane Assist system scans the road ahead and identifies the lanes markers on either side of you. Should you find yourself veering out of your lane, Lane Assist will gently steer you back into place.”<sup>14</sup>

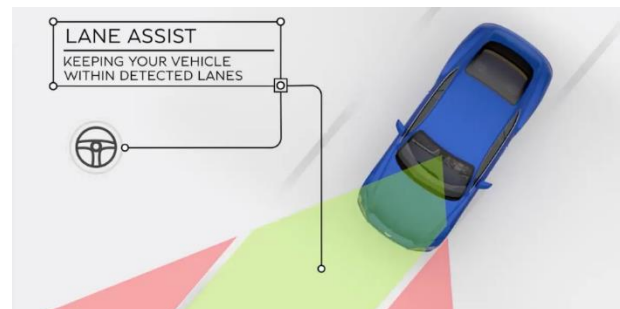

**Bentley Lane Assist graphic  
(Bentley Newport Beach)**

## 8. Bentley EXP 100 GT

The in-cabin driver monitoring system utilizes the following:

Intelligent, Adaptable Biometric Seating can be configured in three different ways, depending on whether the owner is driving or using autonomous mode. Biometric sensors monitor temperature, passenger position and environmental conditions to deliver the ultimate in comfort, whatever the conditions.

Bentley Personal Assistant pre-empts passenger needs and can even maximize comfort based on its knowledge of its owner. For example, reactive seat surfaces respond to passenger position during driving, automatically offering more support when the need is sensed.

In addition, biometrics are embedded throughout the Bentley EXP 100 GT to track eye and head movements, even blood pressure. It represents the future of customized, in-car comfort far beyond any seating experienced in a modern-day car.<sup>15</sup>

This is currently a concept vehicle dating back to 2019. The system it describes mirrors other technologies in development or already developed.

---

<sup>13</sup> “Playing Safe,” Audi Magazine. October 26, 2016. <https://magazine.audi.com.au/article/playing-safe>

<sup>14</sup> “Bentley Lane Assist,” Bentley Newport Beach.

<https://www.bentleynewportbeach.com/research/lane-assist.htm>

<sup>15</sup> “Bentley Reimagines the Future of Grand Touring,” Bentley. July 10, 2019.

<https://www.bentleymedia.com/en/newsitem/957-bentley-reimagines-the-future-of-grand-touring-with-the-extraordinary-bentley-exp-100-gt>

## 9. BMW Active Lane Keeping Assistant

The system “focused on keeping you in your lane safely at speeds up to 130 MPH.” The system works by:

Dynamic radar around the entire vehicle and front cameras monitor road and traffic patterns as well as lane markings.

When you set the system in place, you must keep your hands on the wheel at all times, but the system will provide steering assistance to help you stay in your lane.

In conjunction with BMW adaptive cruise control, this system can help you maintain a set distance not only between lane markers to your side, but also between your BMW and the vehicle in front of you.<sup>16</sup>

### More Information

- BMW Active Lane Keeping Assistant Video: <https://youtu.be/w24HYJvaCl0>.

## 10. BMW Lane Departure Warning

The system acts with a "The camera positioned at the front of the vehicle assists the Lane Departure Warning system. When travelling above 43 mph the system monitors road markings and their position versus the car as well as the edge of the road or lane. The system is activated whenever the vehicle leaves its current lane unintentionally and alerts the driver by making the steering wheel vibrate. When the driver indicates an intention to change the lane by using the indicator, there is no warning signal."<sup>17</sup>

### More Information

- BMW Lane Departure Warning Video:  
[https://www.youtube.com/watch?v=cMd9Fym\\_3fU](https://www.youtube.com/watch?v=cMd9Fym_3fU)

---

<sup>16</sup> “How the BMW Active Lane Keeping and Traffic Jam Assistant Works,” Pacific BMW. June 19, 2018.  
<https://www.pacificbmw.com/how-the-bmw-active-lane-keeping-and-traffic-jam-assistant-works/>

<sup>17</sup> “Active Blind Spot Detection and Lane Departure Warning,” BMW.  
[http://content.bmwusa.com/microsite/f10/com/en/newvehicles/5series/sedan/2010/showroom/safety/lane\\_change\\_departure\\_warning.html#more](http://content.bmwusa.com/microsite/f10/com/en/newvehicles/5series/sedan/2010/showroom/safety/lane_change_departure_warning.html#more)

## 11. BMW

The BMW driver attention monitor captures head and eye movement of driver. The technology looks at a person's eye and analyzes a person head movement.

The system is "driver-facing camera monitors your nose and eyes

to make sure you're facing forward with eyes open."<sup>18</sup> The YouTube video by BMW demonstrates how "the system evaluates the heads positions and opening of the eyes in order to analyze the attentiveness of the driver." The camera is mounted in the instrument panel above the steering wheel.

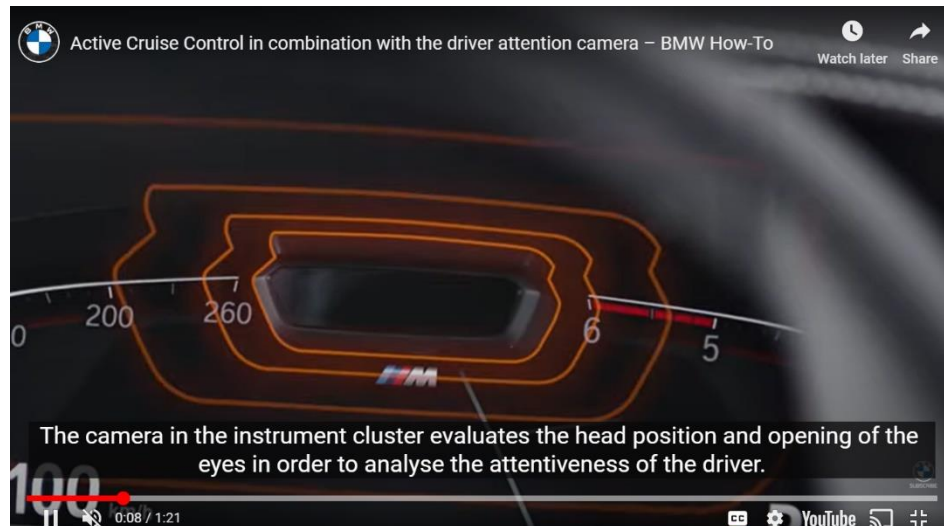

Image of BMW Driver Monitoring System (YouTube)

The technology acts immediately for driver inattention but may be limited to use while a vehicle is stopped. Another limitation is the driver can also turn of this technology.

### More information

- Company Website: <https://www.bmwofminnetonka.com/bmw-active-cruise-control-with-driver-attention-camera/>
- "Active Cruise Control in combination with the driver attention camera – BMW How-To" BMW on YouTube. <https://www.youtube.com/watch?v=LkxgOXuhBUg>
- "Learn How To Use The Driver Attention Camera with Active Cruise Control," Fields BMW Lakeland. <https://www.youtube.com/watch?v=fNZ6NBZITWA>

---

<sup>18</sup> Our Hands-on Experience With the 2019 BMW X7's Hands-Free Driving Mode" Cars.com, August 12, 2019. <https://www.cars.com/articles/our-hands-on-experience-with-the-2019-bmw-x7s-hands-free-driving-mode-407421/>

## 12. Buick Lane Departure Warning

The system works by:

- The feature uses a forward-looking camera
- When a vehicle is in Forward gear and traveling above 35 miles per hour (or 56 kilometers per hour), this sensor looks directly ahead to detect lane lines; when a left or right lane marking is detected, a green icon is displayed
- If the driver lets the vehicle drift over a detected lane marking without intentionally steering or using his/her turn signal, the icon turns amber and flashes to alert the driver to steer back into the lane; plus, beeps are sounded on the lane departure side, or, if equipped, the Safety Alert Seat pulses
- Lane Departure Warning can be turned off
- Lane Departure Warning does not steer the vehicle<sup>19</sup>

The problem with this technology is that it can be turned off and does not correct the steering of the vehicle.

## 13. Buick Lane Keep Assist with Lane Departure Warning

The system “can alert you with a brief, gentle steering-wheel turn when you may be unintentionally drifting out of your lane.”<sup>20</sup> Below is an image of Lane Keep Assist with Lane Departure Warning from Buick.

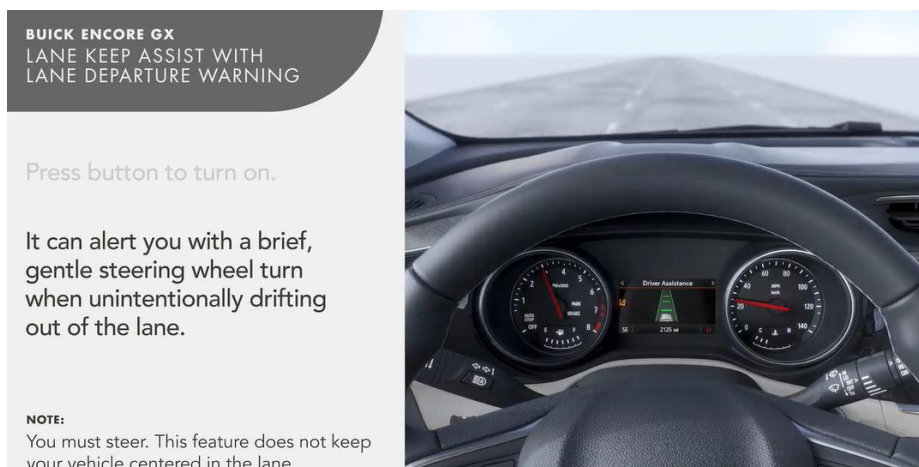

<sup>19</sup> “Lane Departure Warning,” Buick. <https://my.buick.com/how-to-support/interior/warning-lights-alerts/lane-departure-warning>

<sup>20</sup> “Lane Keep Assist with Lane Departure Warning,” Buick. <https://www.buick.com/discover/connectivity/how-to/safety/lane-keep-assist>

## 14. Cadillac Lane Keep Assist with Lane Departure Warning

The systems works in the following fashion:

- When a left or right lane line is detected, a green LANE KEEP ASSIST icon is displayed. The icon will look like either a vehicle with white lines on either side or two lane lines, depending on your vehicle
- If the system anticipates that your vehicle is about to leave its lane unintentionally, an amber LANE KEEP ASSIST icon is displayed. At the same time, a brief “push back,” or nudge, of steering is provided to help keep the vehicle in its lane.
- If the nudge doesn’t prevent the lane departure — if, for example, you’re driving around a curve — and you haven’t reacted, the amber LANE KEEP ASSIST icon will flash when the vehicle leaves the lane. This is a Lane Departure Warning alert. Three beeps or three seat pulses (if your vehicle has a Safety Alert Seat) will occur from the direction of the unintentional lane drift.
- If Lane Keep Assist is on and the feature is unable to detect the lane lines, the LANE KEEP ASSIST icon will turn white.
- When an intentional lane change is detected, the system may provide a steering assist without a Lane Departure Warning.
- If the system detects you may not be steering the vehicle, you may see a TAKE STEERING icon alert.
- If you’re actively steering or using your turn signal, the steering wheel nudges are disabled.<sup>21</sup>

## 15. Cadillac Face Recognition

An article describes it as "Described as “the ultimate keyless experience”, Face ID unlocking and starting is basically a face recognition system that works day and night, indoor and outdoor, and even in some extreme weather."<sup>22</sup>

The system is only available on vehicles in China. The image on the right is from an Ad for the technology from China. It appears there are Patents filed by General Motors for this technology in Mexico.<sup>23</sup>



### More Information

- 2021 Cadillac XT4 Face ID Biometric System Ad: <https://www.youtube.com/watch?v=3-f7qMEx0vQ>

<sup>21</sup> “Lane Keep Assist and Departure Warning,” Cadillac. <https://my.cadillac.com/how-to-support/safety/lane-keep-assist-departure-warning>

<sup>22</sup> “Unlock The 2021 Cadillac XT4 With Your Face – But Only In China,” Carscoops. September 17, 2020. <https://www.carscoops.com/2020/09/unlock-the-2021-cadillac-xt4-with-your-face-but-only-in-china/>

<sup>23</sup> “Cadillac Files To Trademark Modus Biometric System In Mexico,” Cadillac Society. February 2, 2021. <https://cadillacsociety.com/2021/02/14/cadillac-files-to-trademark-modus-biometric-system-in-mexico/>



## 16. Cadillac Super Cruise

Eye and head-based monitoring system that is available as on certain Cadillac vehicles. Camera measures a person's attention while in hands free driving mode. The camera can sense if a person is paying attention. The results are immediate, and driver's seat will vibrate. The technology cannot be used when the vehicle is not in the hands-free mode. The image below is of the technology from Cadillac.

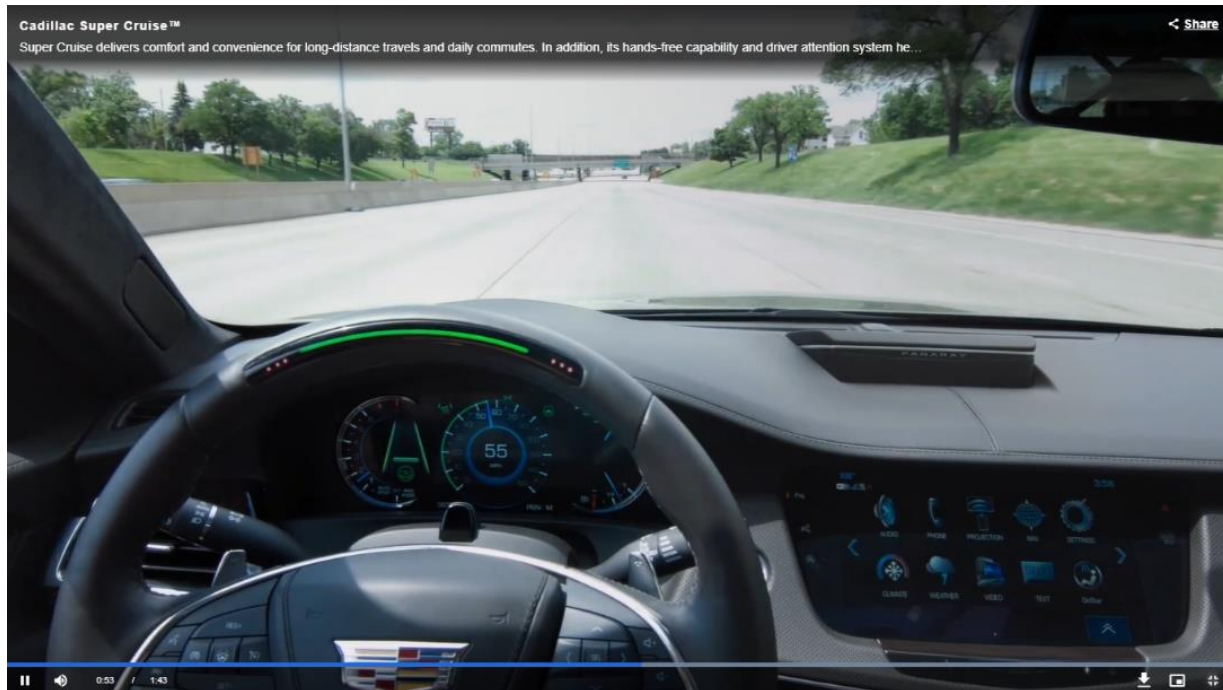

### More Information

- GM website:  
<https://media.gm.com/media/us/en/cadillac/news.detail.html/content/Pages/news/us/en/2017/apr/0410-superdrive.html>

## 17. Chevrolet Lane Keep Assist with Lane Departure Warning

If the system is turned on, the technology works by:

- You'll see a green icon of a vehicle between two lanes when it senses a left or right lane line marking
- If you unintentionally drift near a lane marking without using your turn signal, the icon will turn amber
- The system also gently turns your steering wheel to help guide you back into your lane<sup>24</sup>



Above is a graphic of Chevrolet Lane Keep Assist with Lane Departure warning (Chevrolet)

### More Information

- Lane Keep Assist Video from Chevrolet:  
<https://media.chevrolet.com/media/us/en/chevrolet/bcportal.html/NOPAGE/currentVideoId/4631802883001/currentChannelId/Safety.html>

## 18. Chrysler LaneSense Lane Departure Warning with Lane Keep Assist

The system works by “Standard LaneSense® Lane Departure Warning with Lane Keep Assist automatically helps guide you back into your lane if you’ve drifted outside of it unintentionally.”<sup>25</sup>

### More Information

- Chrysler video of technology:  
<https://www.youtube.com/watch?app=desktop&v=RRi3wulaC9w&feature=youtu.be>

---

<sup>24</sup> “Available Lane Keep Assist with Lane Departure Warning,” Chevrolet. <https://my.chevrolet.com/how-to-support/driving-performance/driving/lane-keep-assist>

<sup>25</sup> “More Standard Safety Features Than Any Vehicle in the Industry,” Chrysler. <https://www.chrysler.com/pacifica/safety-security.html>

## 19. Dodge Lane Sense

The system works like the Chrysler Lane Sense system.

### More Information

- Dodge video of technology: <https://www.youtube.com/watch?v=FvseTfauQs0>

## 20. DS Automobiles

DS Automobiles, owned by Groupe PSA, features the DS Driver Attention Monitoring, which is an eye-based monitoring system. The system features a driver-facing camera that monitor three key physical signs of distraction or drowsiness; movement of the eyes, eyelids or neck. If any signs of distraction are detected, an audible alert is set off and a warning notice appears on the digital instrumentation display. At the same time, vehicle position monitoring constantly tracks the car in relation to road markings and warns the driver with an audible alert if there are any sudden or unexpected steering movements.



Images of DS Driver Attention Monitoring System (YouTube)

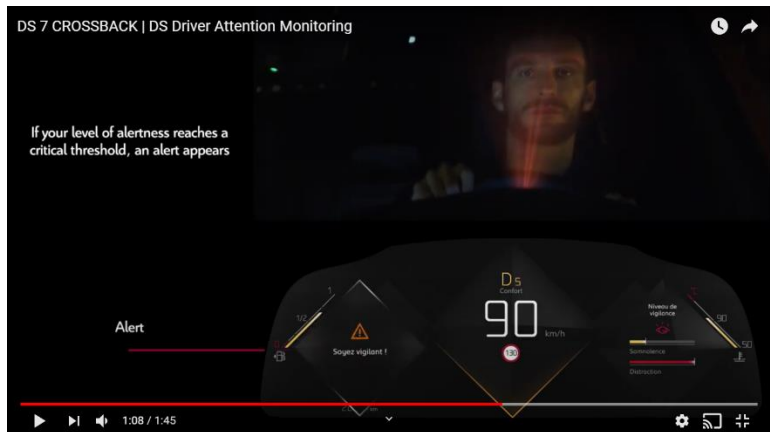

### More Information

- DS Automobiles: <https://www.dsautomobiles.co.uk/inside-ds/ds-news/ds-automobiles-anti-fatigue-technology>
- YouTube Video “DS 7 CROSSBACK | DS Driver Attention Monitoring,” April 26, 2018. <https://www.youtube.com/watch?v=UAVbZIOA3WA>
- “DS Anti-Fatigue Monitoring to Boost Safety,” InformaTech, November 8, 2019. <https://www.tu-auto.com/ds-anti-fatigue-monitoring-to-boost-safety/#>
- “This Is How the DS-7 Crossback Driver Attention Monitoring System Works,” AutoEvolution, November 8, 2019. <https://www.autoevolution.com/news/this-is-how-the-ds-7-crossback-driver-attention-monitoring-system-works-138884.html>

## 21. Mercedes-Benz (Daimler AG) Active Lane Keep Assist

The system “monitors the area in front of your Mercedes-Benz by using a small camera at the top of the car’s windscreen. Radar sensors located all over the vehicle are then in charge of monitoring the traffic around the car.”

The specifics of how the technology works is as follows:

The camera scans the area in front of the car and detects the lane markings on the road (using differences in contrast) and where the vehicle is in relation to these markings. If the car moves towards the white lines then the Active Lane Keeping Assist will alert the driver by vibrating the steering wheel and displaying a warning on the instrument cluster. If the driver does not react and the car begins to leave its lane then it will automatically be brought back into its original lane using a ‘correcting’ application of the brakes.<sup>26</sup>

### More Information

- Video of technology: <https://www.youtube.com/watch?v=OQkdvi55woA>

## 22. Mercedes-Benz (Daimler AG) Attention Assist

The system works as it “calculates an individual behavioural pattern during the first few minutes of every trip. This pattern is then continuously compared with the current steering behaviour and the current driving situation, courtesy of the vehicle's electronic control unit. This process allows the system to detect typical indicators of drowsiness and warn the driver by emitting an audible signal and flashing up an unequivocal instruction on the display in the instrument cluster: "ATTENTION ASSIST. Break!"<sup>27</sup>

The description of the technology also notes how steering behavior can be an indicator of drowsy driving “Observation of steering behaviour has proven to be extremely meaningful as drowsy drivers find it difficult to steer a precise course in their lane.”

### More Information

- Video of technology: <https://www.youtube.com/watch?v=A66zgJ4Oj8o>

---

<sup>26</sup> “What is: Active Lane Keeping Assist,” Mercedes-Benz South West. <https://www.mercedes-benzsouthwest.co.uk/about/news-and-events/active-lane-keeping-assist/>

<sup>27</sup> “Attention Assist: Drowsiness-detection system warns drivers to prevent them falling asleep momentarily,” Daimler. <https://media.daimler.com/marsMediaSite/en/instance/ko/ATTENTION-ASSIST-Drowsiness-detection-system-warns-drivers-to-prevent-them-falling-asleep-momentarily.xhtml?oid=9361586>

## 23. Mercedes-Benz (Daimler AG) Active Emergency Stop Assist

The Mercedes-Benz Active Emergency Stop Assist to stop the vehicle and call for help if the driver is incapable of driving. This system does not use a camera to monitor the driver, but only based off of vehicle movement. The image on the right is taken from a video of a description of the technology.



The automaker describes the technology below:

Active Emergency Stop Assist brakes the vehicle to a standstill in its lane if it detects that the driver is no longer actively driving the vehicle while it is on the move with Active Steering Assist switched on. If there is no steering wheel movement over a longer period when Active Steering Assist is active, the system gives the driver a visual and audible prompt to place his/her hands on the wheel. If the driver fails to respond after repeated visual and acoustic prompts, either by moving the steering wheel, accelerating, braking or by pressing the touch control button on the steering wheel, the car is slowed down in the identified lane until it comes to a standstill. At speeds below approx. 60 km/h the traffic behind is warned by means of hazard warning lights. When the vehicle comes to a standstill, the parking brake is engaged automatically and the Mercedes-Benz emergency call system is activated. The vehicle is also unlocked, to allow first responders access to the interior. The functions are aborted as soon as the driver takes control of the vehicle again.<sup>28</sup>

An article describes how this can stop drowsy driving by stating “It will stop a vehicle if it detects the driver has stopped paying attention or is not actively piloting the vehicle. This safety net deploys when Active Steering Assist is activated. Active Steering Assist, for its part, helps the driver by following lane markings, other vehicles, and features parallel to the road. It maintains the vehicle’s course with a minimum of effort from the driver. All the driver has to do is pay attention.”<sup>29</sup>

### More Information

- Mercedes FAQ 2018 S-Class Sedan: <https://media.mbusa.com/releases/driver-assistance-tech-faq?firstResultIndex=0&sortOrder=PublishedDescending>
- Video of Technology: [https://www.youtube.com/watch?v=J5urCuA6BQE&feature=emb\\_title](https://www.youtube.com/watch?v=J5urCuA6BQE&feature=emb_title)

<sup>28</sup> “Driving assistance systems: High safety standard with functions from the S-Class,” Daimler. <https://media.daimler.com/marsMediaSite/en/instance/ko/Driving-assistance-systems-High-safety-standard-with-functions-from-the-S-Class.xhtml?oid=39951637>

<sup>29</sup> “How Mercedes-Benz Active Emergency Stop Assist Works,” KBB. <https://www.kbb.com/car-news/how-mercedes-benz-active-emergency-stop-assist/>

## 24. Daimler AG Patent: Method for determining the driving ability of a driver in a vehicle

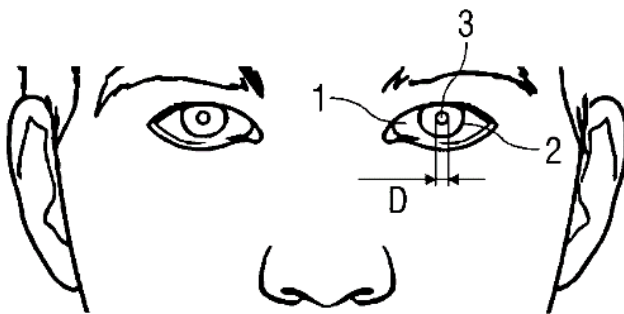

FIG 1A

Daimler AG Patent DE102018009100A1 filed in 2018 is for an eye-based monitoring system. It measures the eye for changes in pupil. The results are immediate, and the eye monitoring measures a previous image of the eye of the user for comparison.<sup>30</sup>

The images on the left are from the Patent. The specific system has not been validated, but similar systems are in development or deployed. Once this technology is available by this Automaker, it is unclear whether or not users will be able to turn of this function.

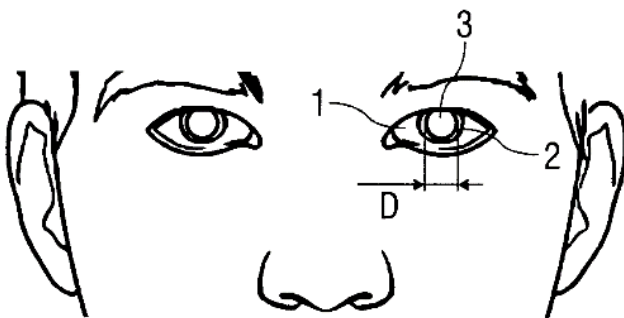

FIG 1B

<sup>30</sup> "Method for determining the driving ability of a driver in a vehicle," Daimler AG. Patent DE102018009100A1. Filed November 11, 2018. <https://patents.google.com/patent/DE102018009100A1/en>

## 25. Fiat LaneSense Lane Departure Warning

The system is described as “Available LaneSense® Lane Departure Warning with Lane Keep Assist alerts you during unintentional lane drifts and will help course correct your vehicle back into its lane if you do not respond.”<sup>31</sup>

### More Information

- Video of Fiat Lane Sense: <https://www.youtube.com/watch?v=dlgo35IlyBA>.

## 26. Fiat Attention Assist

The technology is described as “The system can detect initial signs of fatigue by monitoring lateral movements of the vehicle, advising you when to take a break where necessary via a acoustic and visual warning on the instrumental panel”<sup>32</sup>

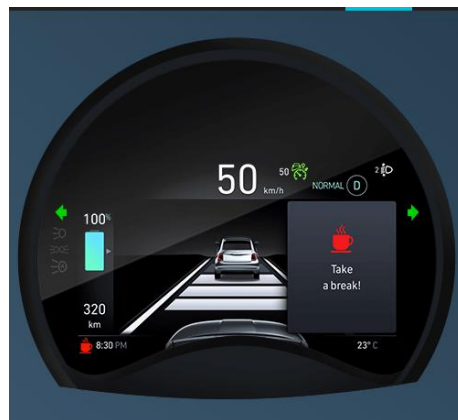

Graphic of Driver Attention Assist (Fiat)

### More Information

- Video of Fiat Attention Assist: <https://www.youtube.com/watch?v=Sg277IqK6I4>

---

<sup>31</sup> “2020 Fiat 500X Teched Out,” Fiat. <https://www.fiatusa.com/500x/technology-and-safety.html>.

<sup>32</sup> “Fiat website. <https://www.fiat.co.uk/500-electric/new-500-hatchback-icon/exterior>.

## 27. Ford Driver Alert

According to Euro NCAP:

Ford's Driver Alert is a driver assistance feature that uses a forward looking camera to monitor the vehicle position in the lane and calculate a vigilance level for the driver. If this vigilance level drops below a certain value (e.g. potentially indicating the driver is tired), the vehicle will issue a visual and audible warning. Additionally, Driver Alert shows the actual vigilance level of the driver in the cluster upon request.

The forward looking camera is constantly monitoring the vehicle position in the driving lane and additionally checks for sudden and exaggerated corrections, which are characteristic of drowsy or inattentive driving. Based on this information and the history of the calculated vigilance level the system issues two levels of warning, a soft- or hard-warning. The soft-warning consists of an audible chime in order to alert the driver to the message in the cluster screen. The hard-warning is triggered if the vigilance level calculated by the system remains below a certain level. It also comes along with an audible chime to alert the driver, but it is now more intrusive to urge the driver to take a rest.<sup>33</sup>



Driver Alert system from Ford (YouTube)

### More Information

- Video of Ford Driver Alert System: <https://www.youtube.com/watch?v=p4jxRhxFHFo>.

## 28. Ford Lane-Keeping System

The system “uses a camera that scans lane markings on both sides of your vehicle. The system has three modes: Lane-Keeping Aid applies steering torque to direct you back to the center of the lane. Lane-Keeping Alert warns you through steering wheel vibrations that simulate driving over a rumble strip. You can set the system to activate either the Alert or Aid mode, or both. And Driver Alert sends out warnings in the message center when it detects repeated lane drifts — a reminder to pull over and take a break.”<sup>34</sup>

### More Information

- Video from Ford on Lane-Keeping System: [https://www.ford.com/global/resources/ford/CoPilot360/HowTo/FMFT2708000H\\_Lane-Keeping\\_System.mp4](https://www.ford.com/global/resources/ford/CoPilot360/HowTo/FMFT2708000H_Lane-Keeping_System.mp4)

<sup>33</sup> “Reward 2011: Ford Driver Alert,” Euro NCAP.

<https://preview.thenewsmarket.com/Previews/NCAP/DocumentAssets/220990.pdf>

<sup>34</sup> “Lane-Keeping System,” Ford. <https://www.ford.com/technology/driver-assist-technology/lane-keeping-system/>.



## 29. Ford BlueCruise

The Ford BlueCruise (Formerly Co-Pilot 360) uses an infrared driver-facing camera to track eye gaze and head position. The system looks at eyes and head position while the car is in hands free mode semi-autonomous driving. Drivers will be notified by visual prompts on their instrument cluster when they need to return their attention to the road or resume control of the vehicle. This technology appears to only work when the vehicle is in hands free mode.



Image of Ford Driver Monitoring System (YouTube)

### More information

- Ford April 14, 2021 press release: <https://media.ford.com/content/fordmedia/fna/us/en/news/2021/04/14/ford-mother-of-all-road-trips-bluecruise-hands-free-driving.html>
- Ford Website: <https://media.ford.com/content/fordmedia/fna/us/en/news/2020/06/18/ford-co-pilot360-technology-adds-hands-free-driving.html>
- “Hands-Free Driving Coming To 2021 Ford Mustang Mach-E,” June 18, 2020. Forbes.com. <https://www.forbes.com/sites/samabuelsamid/2020/06/18/hands-free-driving-coming-to-2021-ford-mustang-mach-e/?sh=7b5076e54113>
- Video of technology from Ford: <https://www.youtube.com/watch?v=x-lg-98jutA>

## 30. Ford

This is a Heart rate-based monitoring system through a seat. Other Driver Monitoring Systems that are being developed or are developed are also able to monitor the heart rate of operators.

According to the Mayo Clinic, consuming three alcohol drinks in one sitting can temporarily increase your blood pressure. An elevated heart rate is associated with higher blood pressure. (NIH, 2013).

The limitations are that changes in a person's heart rate could be for multiple reasons. However, the test results are immediate.

News Articles on this Ford heart rate-based monitor dates back to 2011. Tier 1 suppliers have also explored this technology for vehicles. Seat based heart monitors do not appear to be widely available.

Humans have various reasons for changes in their heart rate. A Heart rate monitor alone cannot be the sole indicator to determine impairment but might be helpful with other driver monitoring systems to ensure redundancy when determining impairment.

### More Information

- "Ford develops heart-monitoring seat" CNET, May 24, 2011. <https://www.cnet.com/news/ford-develops-heart-monitoring-seat/>
- Video: "IFA 2011: Ford Heart Rate Monitoring Seat" YouTube, September 1, 2011. <https://www.youtube.com/watch?v=zIR9kFwngjc>
- "Alcohol: does it affect blood pressure?" Mayo Clinic. <https://www.mayoclinic.org/diseases-conditions/high-blood-pressure/expert-answers/blood-pressure/faq-20058254>
- "Heart Rate and Blood Pressure: Any Possible Implications for Management of Hypertension?" Ruele, Curr. December 2013. <https://www.ncbi.nlm.nih.gov/pmc/articles/PMC3491126/#:~:text=Elevated%20heart%20rate%20is%20associated,consideration%20in%20choosing%20antihypertensive%20medications.>

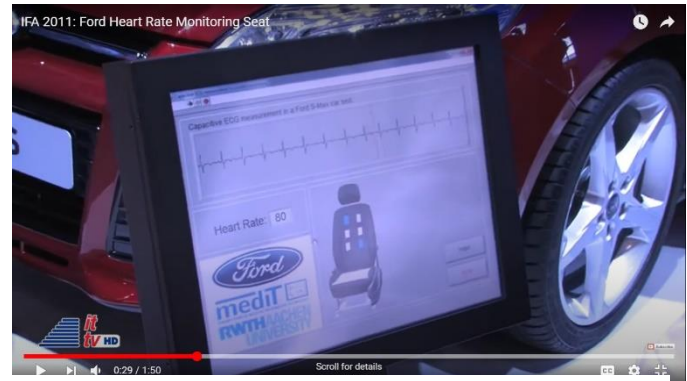

Image of Ford Heart Monitoring System (YouTube)



### 31. Ford Patent: Vehicle Control Handoff

Ford Patent US10838416B1 filed in 2019 is for vehicle control handoff that also includes in-cabin driver monitoring using cameras and other sensors.

The abstract of the Patent states, “ A computer includes a processor and a memory storing instructions executable by the processor to, upon determining that a vehicle entered a geofenced area, start a timer; upon determining that a handoff of the vehicle from an operator to a remote server has not occurred since starting the timer and that the timer has exceeded a time threshold, determine whether the operator is absent based on data from sensors; and then, upon determining that the operator is absent, instruct the vehicle to follow a command received from the remote server.”<sup>35</sup>

**Figure 2** on the right, is a sketch from the Patent. The camera in the cabin is listed as “64”. The cameras are described as “The internal cameras 64 each have a field of view in the passenger cabin 40, e.g., of one or more of the seats 42, 44, 46. For example, as shown in FIG. 2, one of the internal cameras 64 can be mounted on a dashboard or windshield facing rearward toward the driver seat 42. Other internal cameras 64 can be directed to each row of the seats 42, 44, 46. The internal cameras 64 can be any suitable type of image processing device, e.g., visible-light camera, grayscale camera, infrared camera, etc.”

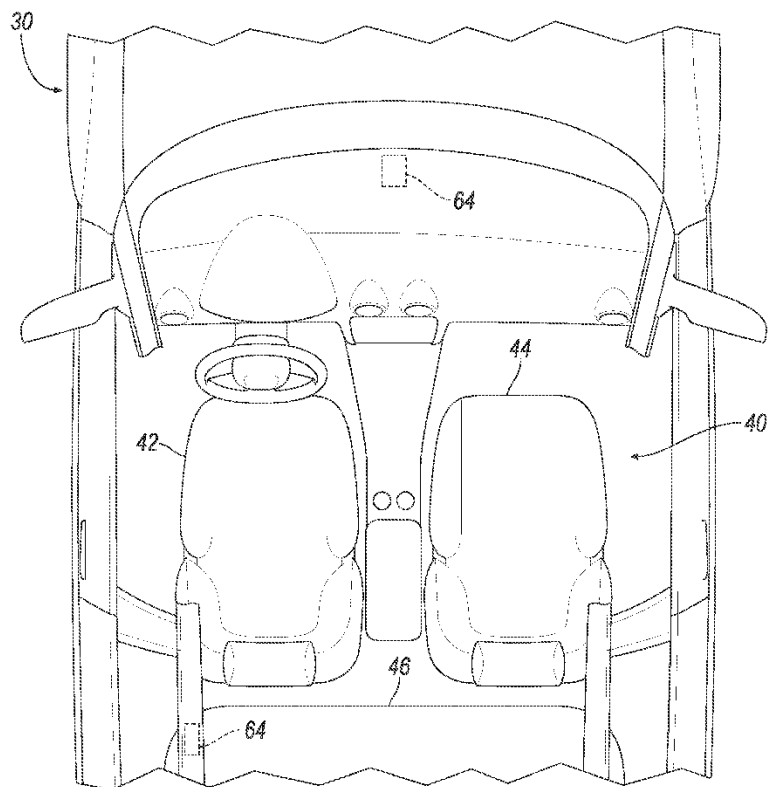

FIG. 2

<sup>35</sup> “Vehicle Control Handoff,” Ford. Patent US10838416B1. Filed May 30, 2019. <https://patents.google.com/patent/US10838416B1>

## 32. Ford Patent: Vehicle Interior and Exterior Monitoring

Ford Patent US20200406902A1 Filed in 2020 uses LIDAR to help determine “a state of a vehicle occupant”<sup>36</sup>

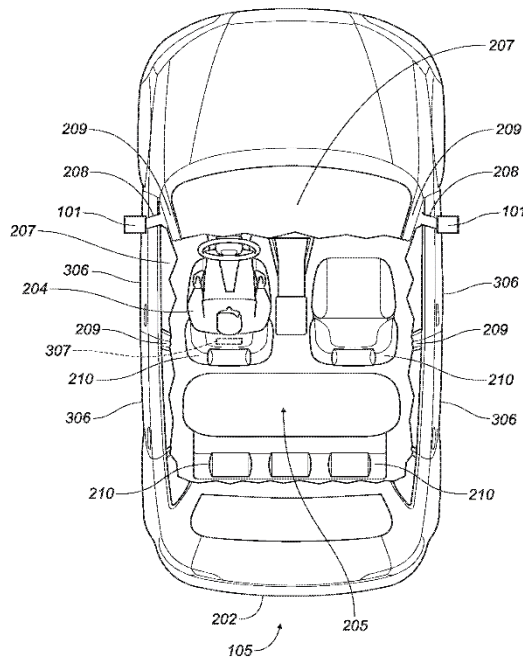

FIG. 2A

**Figure 2A** filed with the Patent shows how LIDAR can, “The partially penetrated radiation may generate a second reflection on another surface behind the transparent object, e.g., an occupant 204 in the vehicle interior 205. **Such a second reflection may provide LIDAR data for creating a 3D map, i.e., a scaled representation such as is known from LIDAR data, of objects inside the vehicle interior 205, including one or more occupants.”**

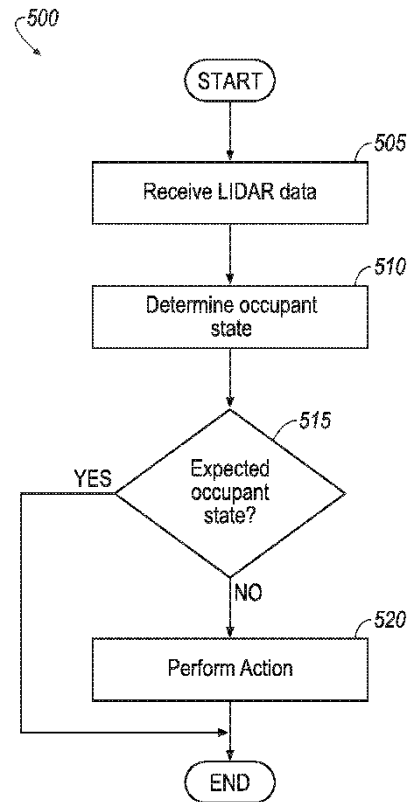

FIG. 5

**Figure 5** “illustrates a process 500 for determining a vehicle 105 occupant 204 state based on data received from LIDAR sensor(s) 101. The process 500 may be carried out according to instructions stored in a memory, and executed by a processor, of the computing device 103.”

This technology appears still in the research and development phase, but it shows that an automaker is looking at technology to determine a driver’s state.

<sup>36</sup> “Vehicle interior and exterior monitoring,” Ford. Patent US20200406902A1. Filed September 10, 2020. <https://patents.google.com/patent/US20200406902A1>



### 34. Ford Patent: System and method for establishing acoustic metrics to detect driver impairment

Ford Patent US9963033B2 filed in 2012 is a voice-based alcohol impairment monitor. The Patent describes the technology:

A system is disclosed herein that utilizes an acoustic phonetic impairment test (APIDT) that uses properties of speech performance to detect driver impairment. For example, the system may compare recorded phrases or words (or random combination of words) to established or initially stored phrases or words, respectively, to assess driver impairment. **Such impairment may be attributed to factors such as driver alcohol consumption, driver glucose levels, illegal drugs, etc.** These factors may change the speech of the driver and such a change may be indicative of the driver being impaired.<sup>38</sup>

Figure 4.B, located to the right, shows how the system would give an audible warnings of impaired driving. “In operation 290, the device 12 generates warnings describing dangers generally associated with impaired driving.”

The Patent shows the Automakers efforts to figure out how to stop impaired driving and by going so far as to generate audible warnings if a vehicle operator is determined to be impaired.

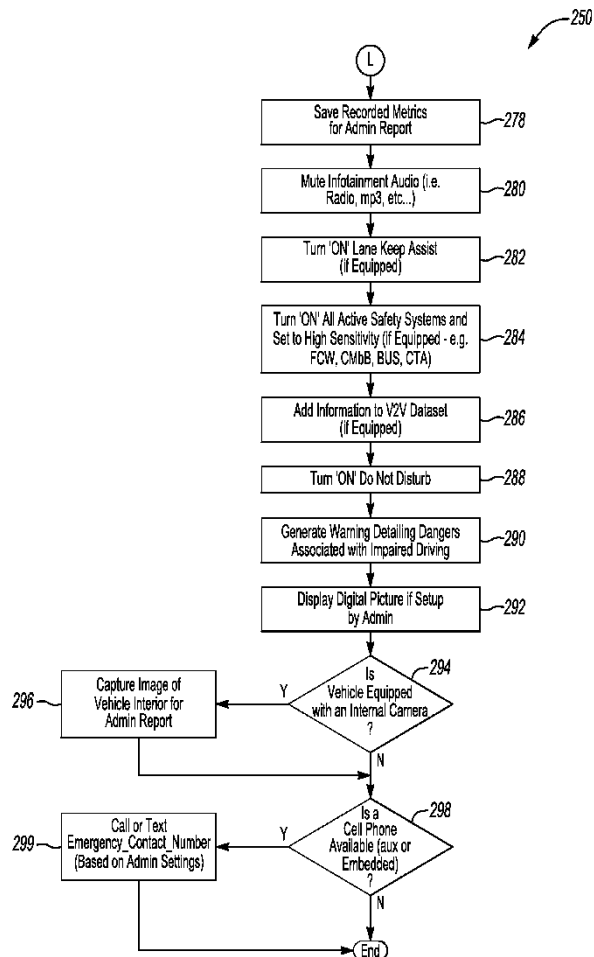

**Fig-4B**

<sup>38</sup> “System and method for establishing acoustic metrics to detect driver impairment,” Ford. Patent US9963033B2. Filed August 9, 2012. <https://patents.google.com/patent/US9963033B2>

### 35. Ford Patent: System and method for selective engine start in a vehicle depending on driving ability

Touch based sensor to determine alcohol or drug impairment on a start/stop ignition button. A sketch associated with the Patent is below.

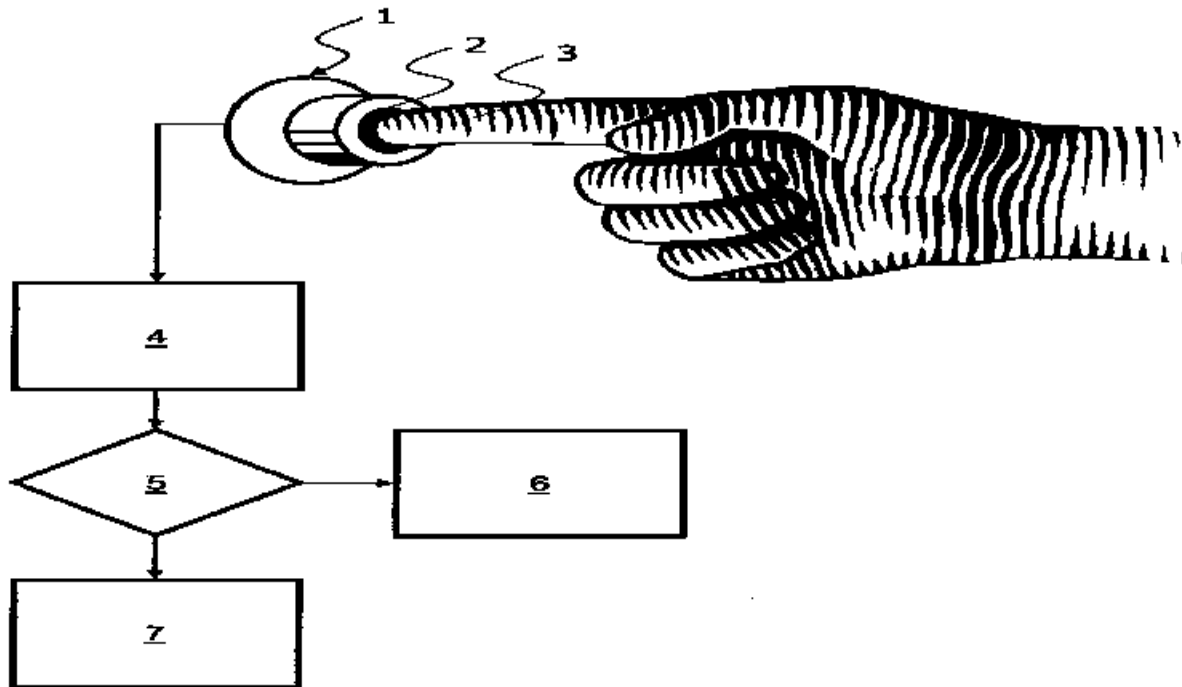

FIG. 1

The Patent was filed in 2006 with the European Patent office.<sup>39</sup> It does not appear anything has happened with this technology.

<sup>39</sup> "System and method for selective engine start in a vehicle depending on driving ability," Ford. Patent EP1849644B1. Filed April 26, 2006. <https://patents.google.com/patent/EP1849644B1/en>

### 36. Ford Patent: Vehicle occupant impairment detection

The Ford Patent filed in 2017 describes a system uses a patch and watch to determine impairment in addition to other sensor to detect impairment. The system also intersects with Autonomous Vehicle technology. The system is described as:

A computer is programmed to receive biometric data, from a transdermal patch in a vehicle during operation of a vehicle, wherein the biometric data include a measurement of a chemical. The computer is programmed to actuate a vehicle component, upon determining from a combination of the measurement of the chemical and vehicle operating data that a risk threshold is exceeded.<sup>40</sup>

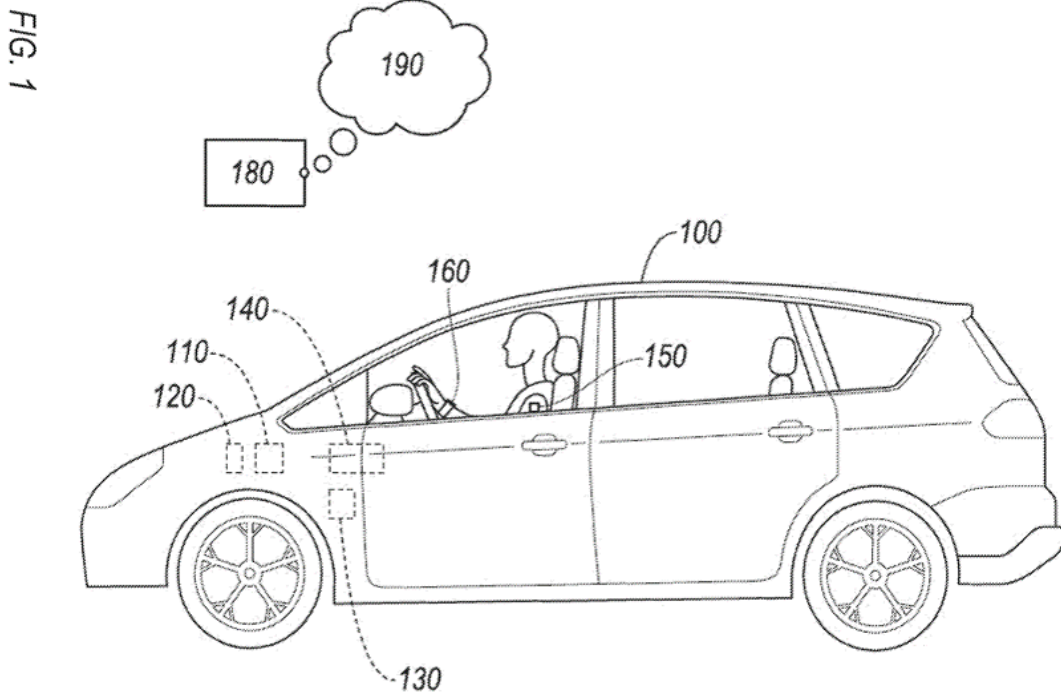

The sketch above from the Patent is of a “Human Machine Interface (HMI) 140 is typically located in a passenger cabin of the vehicle 100. For example, the HMI 140 may provide information to the occupant including an indication of vehicle 100 occupant impairment, an activation of vehicle 100 autonomous mode based on vehicle 100 occupant impairment, etc.”

Any technology that requires an additional step by a driver is not workable. It unclear if this technology has other passive sensors made into the vehicle to determine impairment. This Patent seems to intersect with a vehicle operation in Autonomous Vehicle modes, which is like other technologies by other companies.

<sup>40</sup> “Vehicle occupant impairment detection,” Ford. Patent US20200148231A1. Filed June 16, 2017. <https://patents.google.com/patent/US20200148231A1/en>



### 37. Fuso Lane Departure Warning

The system is described as “Mobileye detects lane markings and alerts the driver if the vehicle leaves the lane without the use of a turn signal.”<sup>41</sup>

It is unclear if the system takes corrective action to guide the driver back into the correct lane.

### 38. Fuso Active Attention Assist

Fuso is 89% Owned by Daimler Truck AG. The Fuso “Active Attention Assist” on commercial trucks tracks head and eye movement to determine driver attention in addition to other features such as tracking for lane departure. The test results are immediate, but a person can turn off the feature and it only operates above certain speeds. The advanced optical sensors utilize facial recognition technology.

Currently, it is a feature only on Fuso commercial vehicles. The user can turn off the feature.



Images of Fuso Active Attention Assist (YouTube)

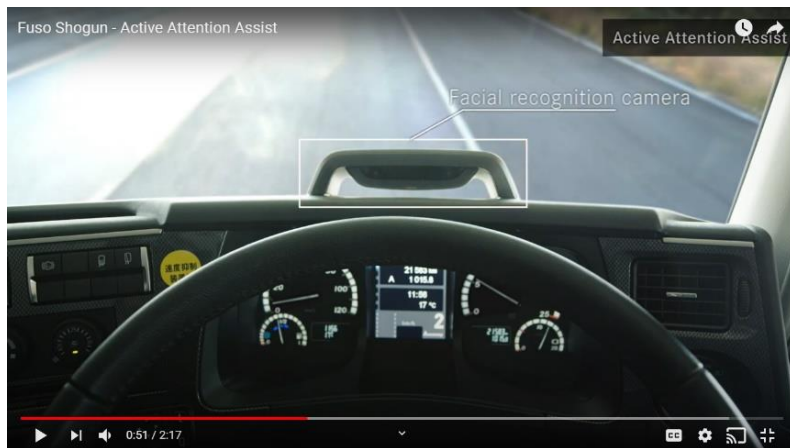

#### More Information

- Fuso New Zealand website: <https://www.fuso.co.nz/news/shogun-first-safety>
- Fuso Active Attention Assist ad: <https://www.youtube.com/watch?v=qcRADEWxTgM>

<sup>41</sup> “Safety Features,” Fuso. <https://www.mitfuso.com/en-us/advantage/safety>

### 39. Genesis Lane Keep Assist

The systems “Drift outside your lane without signalling and the Lane Keep Assist system first warns you with haptic vibrations through the steering wheel, as well as audible and visual cues. If the vehicle continues to approach the edge of its current lane, Lane Keep Assist can provide steering assistance to bring the vehicle back on course.”<sup>42</sup>



The image to the right is a graphic from the Genesis website showing how the technology works.

### 40. Genesis Driver Attention Warning

The system “analyses driving patterns of the driver and the vehicle’s position in the lane to operate a 5-stage warning system. It posts pop-up messages and sets off warning signals to encourage the driver to rest when driver fatigue or inattentive driving is detected.”<sup>43</sup>



The image on the right is from the Genesis website of the coffee icon that appears when a person may be fatigued. This feature, like many other Automakers safety features can be disabled by the driver.

#### More Information

- Genesis G80 Driver Attention Assist video: <https://www.youtube.com/watch?app=desktop&v=rDxtYEW36g>
- Video of GV80 Driver Attention Warning: <https://www.youtube.com/watch?app=desktop&v=1gktZsO9kFo>.

<sup>42</sup> “Compromising Nothing on Safety and Comfort,” Genesis. <https://www.genesis.com/ca/en/luxury-sedan-genesis-g70-safety.html>

<sup>43</sup> “Driver Attention Warning,” Genesis. <https://www.genesis.com/au/en/luxury-sedan-genesis-g70-safety.html>

## 41. Genesis Forward Attention Warning

The Genesis “Forward Attention Warning” checks driver face with IR optical camera installed on the instrument cluster. The system “helps limit the dangers of driver fatigue and tiredness by reading the face of the driver through an IR camera built right into the dashboard”

The test is immediate and fatigue is noted: “When the system detects closed eyes or lack of attention, it warns the driver with pop-up notifications and an acoustic warning sound designed to effectively secure the driver’s attention.”<sup>44</sup>

It is advertised as a new option on vehicles. The technology is dependent on a person opting for this technology to be installed in the vehicle that they purchase. The person could also turn off the system if it is installed in their vehicle.



Images of Genesis Forward Attention Warning (YouTube)



### More Information

- Video of G80 and GV80 Forward Attention Warning  
[https://www.youtube.com/watch?v=wEj03gpM4rc&list=PLW77CkZQxeR3la\\_pcxVnDiB7ziv04ZE3a](https://www.youtube.com/watch?v=wEj03gpM4rc&list=PLW77CkZQxeR3la_pcxVnDiB7ziv04ZE3a)

<sup>44</sup> “Steady, Study, and Secure,” Genesis. <https://www.genesis.com/ca/en/luxury-suv-genesis-gv80-safety.html>

## 42. GM Patent: Vehicle immobilizer methods and apparatus based on driver impairment

GM Patent U S8196694B2 filed in 2009 is driver monitoring technology for impairment. The Patent is described:

Impairment sensor system 108 includes an analyzer adapted to estimate an impairment-related metric (“IRM”) (e.g., blood alcohol content) from a non-invasive interaction with a vehicle operator (e.g., from a breath sample). **The analyzer may include, for example, an ethanol-specific fuel cell sensor, which generates an electric current having a magnitude that is related to a concentration of alcohol within a breath sample. Alternatively, the analyzer may utilize infrared spectroscopy or other technologies for detecting a concentration of alcohol from transdermal images.** From the detected alcohol concentration, the impairment sensor system 108 may determine a detected blood alcohol concentration<sup>45</sup>

It is unclear where this system is in the process. The sketch below is from the Patent filed for this technology.

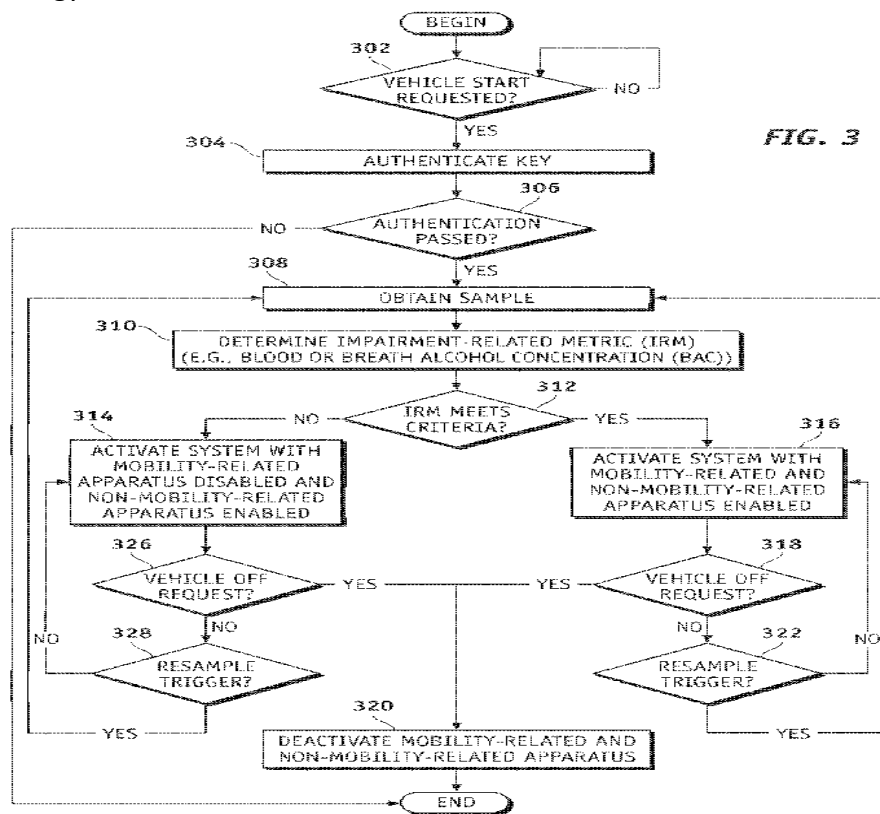

<sup>45</sup> “Vehicle immobilizer methods and apparatus based on driver impairment,” GM. Patent US8196694B2. Filed May 21, 2009. <https://patents.google.com/patent/US8196694B2>

### 43. GM Patent: Method and system for mitigating the effects of an impaired driver

GM Patent US9290174B1 filed in is for driver monitoring system for impairment, and measures for intoxications, while also intersects with autonomous vehicle technology.

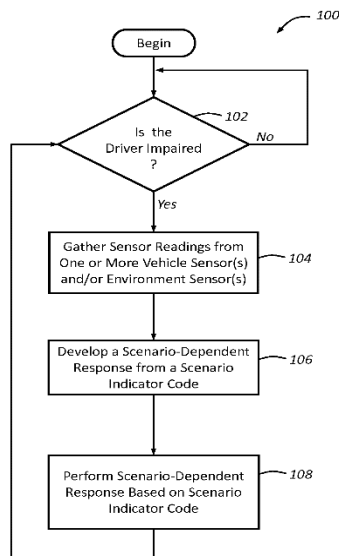

**Figure 2**

The sketches are from the Patent. They show the intersection of determining a driver state and engaging autonomous vehicle driving mode.

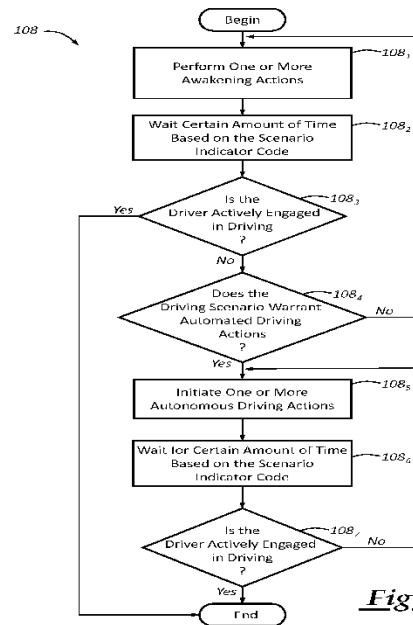

**Figure 5**

Figure 2 above shows a basic overview on how the system determines impairment, including that for intoxication as also described below from the Patent:

Beginning with step 102, the method determines whether the driver of the host vehicle is impaired, and may do so in any number of different ways. **An impaired driver may be a sleepy or drowsy driver, an injured or debilitated driver, or an intoxicated driver**, for example. Step 102 may employ any known method or technique for detecting an impaired driver, including techniques that rely on driver readings from driver sensors 18 to capture and evaluate images of the driver's face in order to look for slackening facial muscles, to evaluate the frequency, duration and/or pattern of eye closure, to examine the orientation or movement of the driver's head or body, or to monitor the direction or pattern of the driver's gaze, to cite a few possibilities. Movement of the driver may also be monitored by sensors located in the driver's seat to detect driver position, as well as sensors in the steering wheel to monitor the driver's hand position. In other examples, driver impairment is determined not by directly monitoring the face or body of the driver, but by evaluating the behavior or performance of the driver and looking for signs of impairment such as lane departure, inconsistent vehicle speed, erratic driving, etc.<sup>46</sup>

Other auto companies have developed similar systems monitoring a driver and determining when Autonomous Vehicle will be engaged. It is unclear where GM is at with rolling out this technology.

<sup>46</sup> "Method and system for mitigating the effects of an impaired driver," GM. Patent US9290174B1. Filed October 23, 2014. <https://patents.google.com/patent/US9290174B1/en?q=9290174>

#### 44. GM Patent: Method and apparatus for detecting projected impairment

GM Patent US20180037228A1 filed in 2016 is for a system monitors for impairment including for that of alcohol or other drugs. The Patent seems to have application with autonomous vehicle technology or finding a different mode of transportation if the driver is determined impaired. The Patent abstract describes a comprehensive system that:

The method includes detecting a first impairment level at a first time; detecting a second impairment level at a second time after the first time; based on the detected first impairment level and the detected second impairment level, determining a third impairment level at a third time after the second time; and inhibiting vehicle operation in response to determining that the third impairment level is greater than an impairment threshold. The apparatus and method may be used in a vehicle or other apparatus to prevent vehicle operator from operating the vehicle while impaired or prior to becoming impaired.<sup>47</sup>

**The sketches to the right are from the Patent shows notification to warn of impairment**

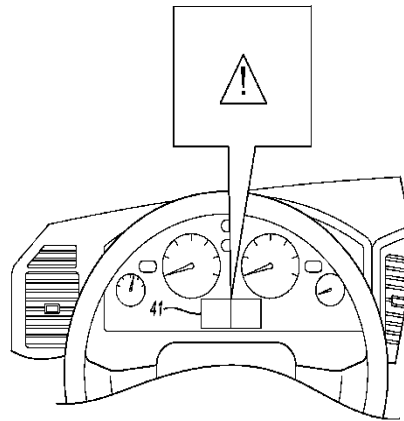

**Fig-4A**

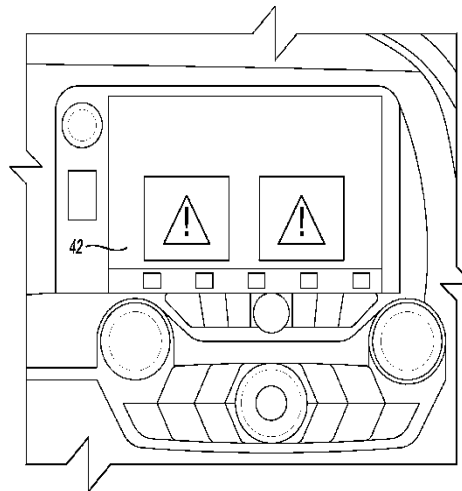

**Fig-4B**

The Patent appears to allow for the user to call or request a ride if the driver is determined impaired by the system. It is unclear if this technology has been developed or not.

---

<sup>47</sup> "Method and apparatus for detecting projected impairment," GM. Patent US20180037228A1. Filed August 5, 2016. <https://patents.google.com/patent/US20180037228A1>.

## 45. GM Patent: Drive-cycle sampling and monitoring for impairment detection system

GM Patent US10507844B2 filed in 2017 shows a system that monitors for forms of impairment including for those impaired by a substance. The system also seems to allow for the vehicle to take control if the driver is too impaired to operate a vehicle either by a substance or other form of impairment.

As it relates to measure for alcohol-impairment, this is the description from the Patent:

The impairment measurement device 198 may measure a BAC each time a driver requests the starting of the engine 102 (e.g., each time and ignition key, button, or switch is operated). Alternatively, the impairment measurement device 198 may measure a BAC each time the ignition state 178 transitions to one or more of the “on” power modes (e.g., accessory, run, and/or crank). In addition, the impairment measurement device 198 may periodically measure a BAC during operation of the vehicle. This enables appropriate responses even if the impairment value changes during operation, as could be the case if the driver drinks alcohol while driving or shortly prior to driving the vehicle. The time between measurements, or a sample frequency, may be determined by the impairment control module 196.<sup>48</sup>

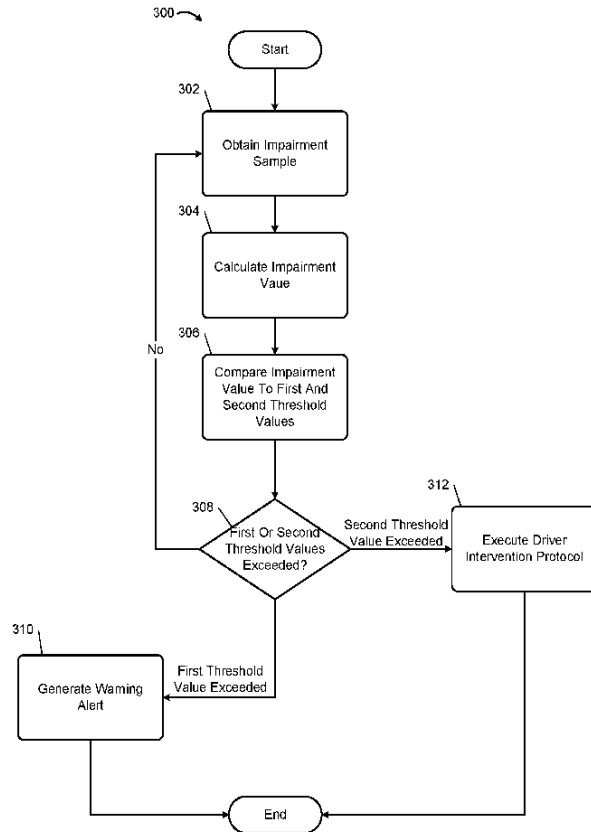

**FIG. 3**

**The sketch is from the Patent, which describes how substance impairment is determined.**

There appears to be a method in this Patent for the vehicle to take control if the driver too impaired. This is similar to other technologies developed by other companies.

<sup>48</sup> “Drive-cycle sampling and monitoring for impairment detection system,” GM. Patent US10507844B2. Filed September 26, 2017. <https://patents.google.com/patent/US10507844B2/en?q=10507844>.

## 46. GM Patent: System and method to restrict vehicle operations in response to driver impairment

GM Patent US10471969B1 filed 2019 monitors for driver impairment and intersects with autonomous vehicle technology if a driver's state is too impaired by substance or unable to operate a vehicle.

The Patent notes the importance of detecting intoxication when it comes to autonomous vehicle technology "It is therefore desirable to restrict vehicle occupants from shifting their autonomous vehicle to a manual driving mode while they are intoxicated. It is further desirable to automatically transfer the autonomous vehicle out of its manual driving mode when its occupant(s) are detected as being impaired"<sup>49</sup>

The technology outlined in the Patent is very similar to other technologies that aim to determine when the driver should go into autonomous vehicle driving mode depending on the state on the driver.

## 47. GMC Lane Keep Assist with Lane Departure Warning

The system "can help you avoid crashes due to unintentionally drifting out of your lane by providing gentle steering-wheel turns when the system detects you are drifting out of your lane with no turn signal or steering activity. It can also provide Lane Departure Warning alerts when a lane marker is crossed."<sup>50</sup>

### More Information

- GMC video of the technology: [https://www.youtube.com/watch?v=bf\\_KkfmhcMY](https://www.youtube.com/watch?v=bf_KkfmhcMY)

## 48. Honda Lane Departure Warning

The system "uses a windshield camera to visually detect lane lines in the road. If the driver begins to drift out of a detected lane without using the turn indicators, the system will alert the driver with an icon in the instrument panel and an audible warning, though the driver remains responsible for safely operating the vehicle and avoiding collisions."<sup>51</sup> This system does not take corrective action if the driver crosses the lane.

---

<sup>49</sup> "System and method to restrict vehicle operations in response to driver impairment," GM. Patent US10471969B1. Filed January 7, 2019. <https://patents.google.com/patent/US10471969B1/en?q=10471969>.

<sup>50</sup> "Advanced Safety and Driver-Assistance Features," GM. <https://www.gmc.com/safety-features>

<sup>51</sup> "Lane Departure Warning," Honda Info Center. <https://www.hondainfocenter.com/2021/CR-V/Feature-Guide/Safety-Features/Lane-Departure-Warning-LDW/>



## 49. Honda Lane Keeping Assist System

The system is “designed to help keep a vehicle centered in a detected lane, applying mild steering torque if it determines the vehicle is drifting toward the side of the lane....It uses a windshield-mounted camera to look for lane markers, and the Electric Power Steering (EPS) to help steer the vehicle. The system is able to identify Botts’ Dots and other lane markings, and works at speeds between 45 mph and 90 mph. If LKAS determines the vehicle is deviating from the center of a detected lane with no turn-signal activation by the driver, it will attempt to steer the vehicle back into the center of the lane.”<sup>52</sup>

## 50. Honda Driver Attention Monitor

The system “continually monitors and assesses driver behavior behind the wheel to help determine if the driver is becoming inattentive – and then if so, warn the driver to take a break.”<sup>53</sup>

The system works in the following way:

- This feature uses an angle sensor to measure the degree of steering-wheel corrections by the driver to maintain a proper lane position.
- If it senses too much correction activity, it will notify the driver to take a break.
- If normal attention levels are detected, the monitor will display three or four bars in the driver-selectable Driver Attention Monitor screen in the Driver Information Interface.
- If the system detects an inadequate level of attention, the system will override any of the other selected screens, and display either one or two bars and a message advising the driver to take a break.
- If the detected level of attention worsens, the system will display a heightened visual warning as well as an audio alert, and will vibrate the steering wheel to further warn the driver to take action.<sup>54</sup>

### More Information

- Honda Driver Attention Monitor video:  
[https://www.youtube.com/watch?v=FkWkTei\\_Mc8](https://www.youtube.com/watch?v=FkWkTei_Mc8)

---

<sup>52</sup> “Lane Keeping Assist System,” Honda Info Center. <https://www.hondainfocenter.com/2021/CR-V/Feature-Guide/Interior-Features/Lane-Keeping-Assist-System-LKAS/>

<sup>53</sup> “Driver Attention Monitoring System,” Honda Middle East. <https://www.honda-mideast.com/en/safety/Driver-Attention-Monitoring-System>

<sup>54</sup> “Driver Attention Monitor,” Honda Info Center. <https://www.hondainfocenter.com/2021/CR-V/Feature-Guide/Interior-Features/Driver-Attention-Monitor/>

## 51. Honda Sensing Elite Safety System

This is a camera driver monitoring system of the driver that is advertised as being the “first Level 3 automated technology to be approved by Japanese authorities.” The system “tracks the condition of the driver using a monitoring camera mounted inside the vehicle.”<sup>55</sup>

This technology shows how automakers are preparing for autonomous vehicles and specifically when a vehicle should be in control and when the driver should be in control. The intersection with autonomous driving and the need for driver monitoring and for when and when not the vehicle can give control back to the driver based on the driver’s condition is noted “Interior equipment exclusive to this model includes Honda SENSING Elite indicator lights, which feature carefully selected and visible positions, sizes, colors, brightness and other details, as well as a 12.3-inch full-LCD graphic meter. This equipment was adopted to provide an intuitive understanding of system operation status, current driving situation and any requests to transfer control back to the driver.”

The image below is from Honda of the technology.



### More Information

- Video of Technology: <https://www.youtube.com/watch?v=RCai6FEuGvc>

---

<sup>55</sup> “Honda launches next generation Honda SENSING Elite safety system with Level 3 automated driving features in Japan,” Honda. March 4, 2021. <https://hondanews.com/en-US/honda-corporate/releases/release-e86048ba0d6e80b260e72d443f0e4d47-honda-launches-next-generation-honda-sensing-elite-safety-system-with-level-3-automated-driving-features-in-japan>

## 52. Honda Patent: System and method for capturing and decontaminating photoplethysmography (PPG) signals in a vehicle

Honda Patent US10153796B2 filed in 2015 is for technology that can measure body and face to determine impairment. The Patent says “additionally, the optical sensors 202 can noninvasively monitor a condition of the driver 118 through the determination of biological signals, such as body-trunk plethysmograph and respiration that are detected from the driver’s back from one or more optical sensors 202 included within sensor assemblies 120 disposed at the seat back 134 of the vehicle seat 122. In particular, one or more filtered signals can be evaluated to determine the driver’s PPG signals that fall between normal and intoxicated states in order to determine driver intoxication.”<sup>56</sup>

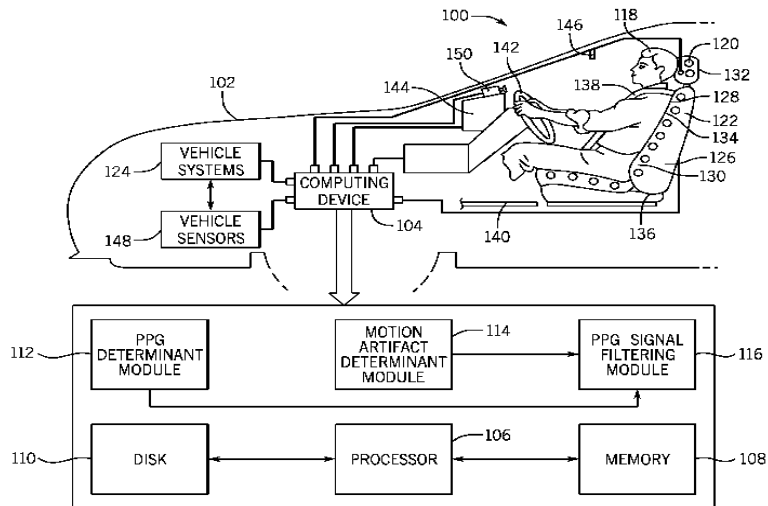

Drawings from Patent

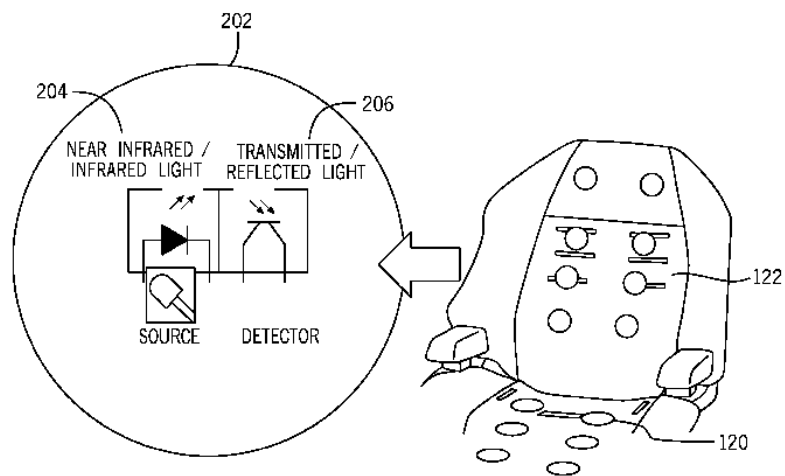

FIG. 2A

The results seems immediate under this patent. The technology appears to use: seat sensors, Skin sensors, and optical sensors.

<sup>56</sup> “System and method for capturing and decontaminating photoplethysmography (PPG) signals in a vehicle,” Honda. Patent US10153796B2. Filed April 27, 2015. <https://patents.google.com/patent/US10153796B2>.

### 53. Honda Patent: System and method for responding to driver behavior

Honda Patent US20180072310A1 filed in 2017 is for technology that monitors: heart, eyes, face, brain waves and entire driver body state. The Patent states “In particular, the level of drowsiness may be detected by sensing different degrees of driver behavior. For example, as discussed below, drowsiness in a driver may be detected by sensing eyelid movement and/or head movement. In some cases, the degree of eyelid movement (the degree to which the eyes are open or closed) or the degree of head movement (how tilted the head is) could be used to determine the body state index. In other cases, the autonomic monitoring systems could be used to determine the body state index. In still other cases, the vehicle systems could be used to determine the body state index. For example, the degree of unusual steering behavior or the degree of lane departures may indicate a certain body state index.”<sup>57</sup>

Portions of this driver monitoring system described in this patent have been advertised or are in development by other OEM, Tier 1 and Tier 2 suppliers.

The drawing on the right are taken from the Patent.

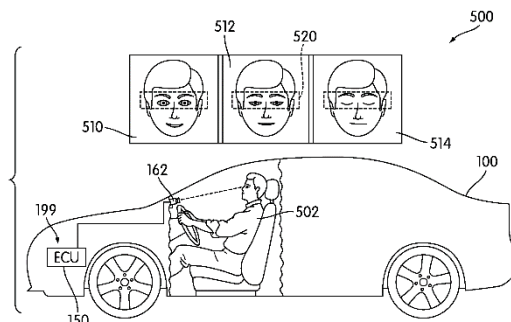

FIG. 11

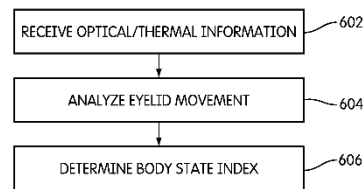

FIG. 12

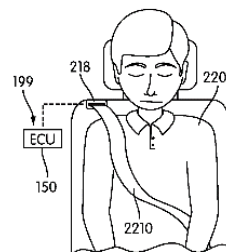

FIG. 33

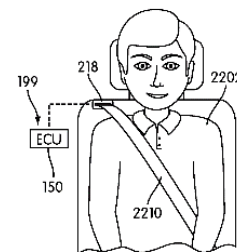

FIG. 34

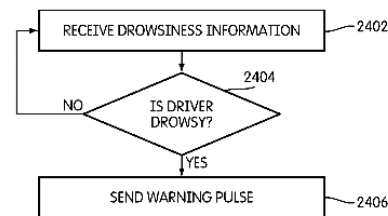

FIG. 35

<sup>57</sup> “System and method for responding to driver behavior,” Honda. Patent US20180072310A1. Filed June 29, 2017. <https://patents.google.com/patent/US20180072310A1>



## 55. Honda Patent: System and method for dynamic vehicle control affecting sleep states of vehicle occupants

Honda Patent US9463805B2 filed in 2014 is for this driver monitoring system relating to sleep states of driver and occupants. The Patent says:

The method includes determining a target sleep state of the vehicle occupant based on at least one of the state of the vehicle occupant, the physiological data and vehicle system data and controlling a vehicle system of the vehicle based on the state of the vehicle occupant in relation to the target sleep state. The method includes monitoring the state of the vehicle occupant including monitoring the physiological data of the vehicle occupant in response to controlling the vehicle system and controlling the vehicle system according to the monitoring in relation to the target sleep state.

The monitoring system 202 of FIG. 2 can sense and determine physiological data of one or more vehicle occupants. For example, the monitoring system 202 can include one or more bio-monitoring sensors, heart rate sensors, blood pressure sensors, oxygen content sensors, respiratory sensors, perspiration sensors, imaging sensors to sense eye movement, pupil dilation, gestures, as well as any other kinds of sensors for monitoring one or more vehicle occupants (e.g., vehicle sensors 124). It is understood that said sensors of the monitoring system 202 could be disposed in any location of a vehicle (e.g., the vehicle 300, FIG. 3). For example, sensors could be disposed in a steering wheel, seat, armrest or other component to detect physiological data associated with the one or more vehicle occupants.<sup>59</sup>

This system has not been validated to date. It does show an overall pattern of how Honda is developing driver monitoring systems to determine a driver's state. As this Patent seems more in-line with the automaker researching a driver's state, it seems this tech would not be acceptable. However, it shows the automaker is looking into driver monitoring especially when looking at other patents filed by this automaker which are more specific to passively monitoring a driver's state.

---

<sup>59</sup> "System and method for dynamic vehicle control affecting sleep states of vehicle occupants," Honda. Patent US9463805B2. Filed December 17, 2014. <https://patents.google.com/patent/US9463805B2>

## 56. Honda Patent: System and method for responding to driver state

The Patent originally filed in 2015 and updated in 2017, 2019, and 2020 relates to driver monitoring to detect impaired drivers and the intersection with autonomous vehicle technology. The Patent is very extensive and includes over 144 sketches of the technology.

Under the Patent, the determination of alcohol impairment is as follows:

In another embodiment, the ECU 106 can determine blood alcohol content (BAC) (e.g., blood alcohol levels) of the driver from information received by the blood alcohol content sensors 310. For example, an optical sensor can emit light towards the driver's skin and measure a tissue alcohol concentration based on the amount of light that is reflected back by the skin. The BAC can be analyzed to determine if the BAC coincides with a particular physiological driver state. For example, high BAC can coincide with an impaired/distracted driver state (e.g., an intoxicated driver).

The optical and thermal sensing devices can be used to monitor physiological information, for example, heart rate, pulse, blood flow, skin color, pupil dilation, respiratory rate, oxygen content, **blood alcohol**<sup>60</sup>

The sketch on the right is from the patent. 310 on the right shows that blood alcohol content sensors are part of the monitoring system. The Sketch also shows the many other sensors built into the technology to monitor the driver.

The Honda monitoring system also intersects with autonomous vehicle technology and seems to allow for the vehicle to take control if the drive is impaired in some fashion. The Patent has a lot of sensors associated with the DMS that monitor everything from the eyes, BAC, heart to the Brain.

This technology seems similar in concept to other technologies developed or in development by other auto companies.

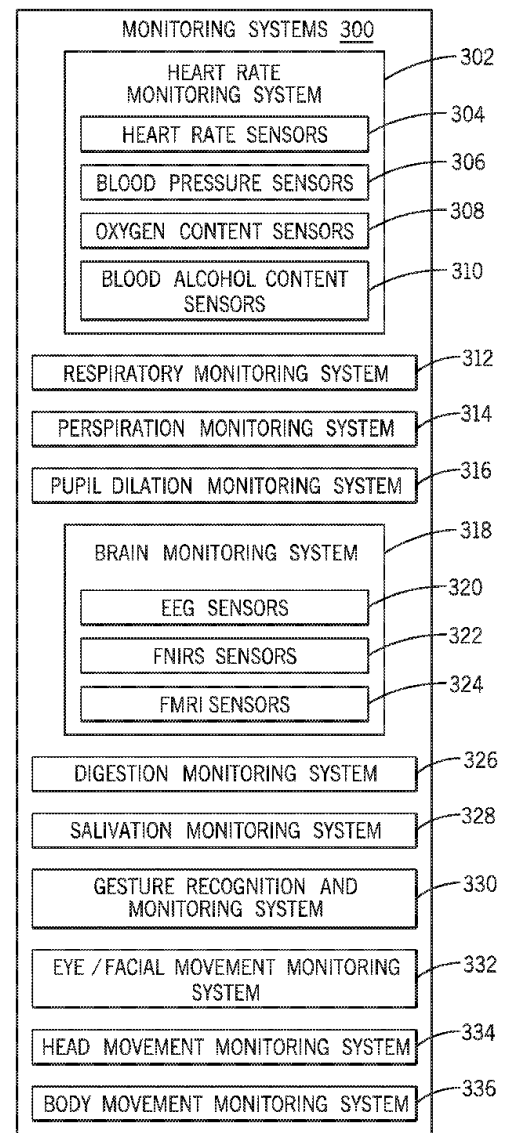
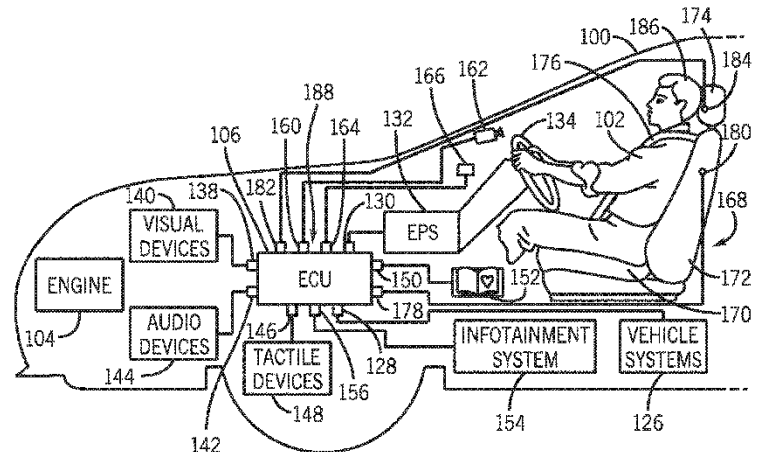

FIG. 3

<sup>60</sup> "System and method for responding to driver state," Honda. Patent US107594 <https://patents.google.com/patent/US10759437B2/en>

## 57. Honda Patent: Vehicle control system

Honda Patent US9073431B2 filed in 2014 is for alcohol detector level for the driver of the vehicle. From the abstract:

A vehicle control system includes an alcohol detector which detects an alcohol intake level of a driver of a vehicle; and a controller which determines whether the driver is a drunk person based on a detection result obtained from the alcohol detector, and which stops the vehicle when a determination result that the driver is the drunk person is obtained. After a door of the vehicle is switched from a closed state to an open state, and before an operation of a start-up of the vehicle is performed, the controller controls the alcohol detector so that a detection of the alcohol intake level is started, and allows a travelling of the vehicle before the detection result is output from the alcohol detector.<sup>61</sup>

The sketch above the Patent shows the working of the alcohol sensors. The patent describes this sketch:

The alcohol detector 11 is disposed in the vicinity of a driver seat 1 a of a vehicle 1. For example, the alcohol detector 11 includes a breathalyzer type alcohol sensor 11A that is provided on an upper surface of a steering column cover 31, a breathalyzer type alcohol sensor 11B that is disposed on an instrument panel 33 farther outside than a steering wheel 32 in a width direction of the vehicle 1, and two touch type alcohol sensors 11C that are provided on the steering wheel 32.

Each of the breathalyzer type alcohol sensors 11A and 11B detects an alcohol density in an exhalation of a driver of the vehicle 1 as an alcohol intake level of the driver, and outputs a signal indicating a detection result of the alcohol density to the controller 14.

Each of the touch type alcohol sensors 11C detects the alcohol density in the sweat secreted from surfaces of the palm or the fingers of the driver, or in the subcutaneous tissues of the driver as the alcohol intake level, and outputs the signal indicating the detection result of the alcohol density to the controller 14.

It is unclear if this technology has been incorporated into another Honda Patent or other technology, but this technology has yet to be announced.

FIG. 1

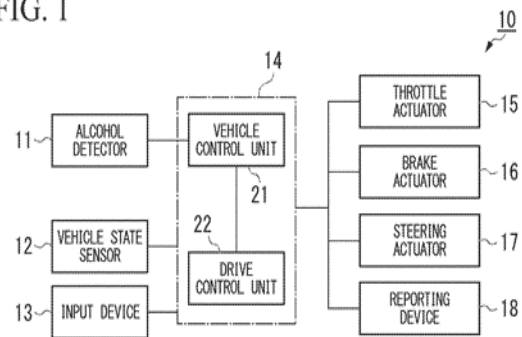
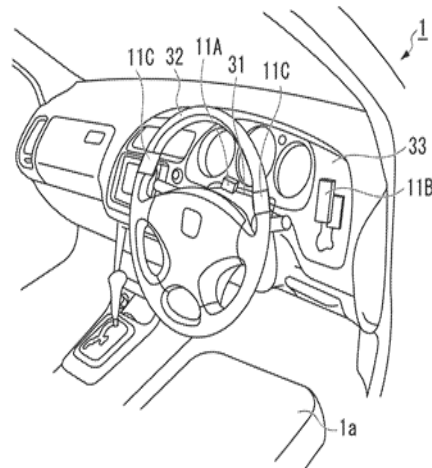

FIG. 2



<sup>61</sup> "Vehicle control system," Honda. Patent US9073431B2. Filed March 31, 2014. <https://patents.google.com/patent/US9073431B2/en?q=9073431>



## 58. Honda

Honda Patent US10789973B2 filed in 2018 could determine if a driver is intoxicated based off speech recognition. The technology also intersects and could enable autonomous vehicle driving technology. The Patent states:

The controller may automatically enable autonomous driving based on the estimated state of the driver being intoxicated. The system may include a transmitter transmitting a warning signal to a mobile device based on the estimated state of the driver. The system may include a transmitter transmitting a rideshare signal to a mobile device associated with launching a rideshare application based on the estimated state of the driver. The system may include a display displaying a warning notification based on the estimated state of the driver.<sup>62</sup>

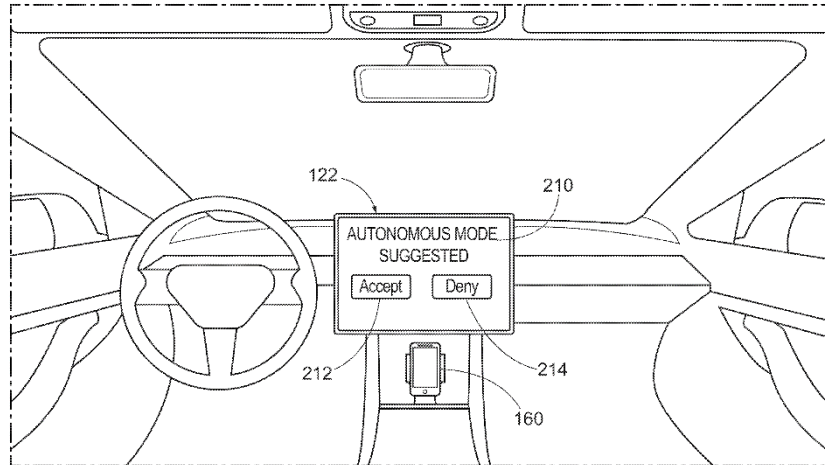

FIG. 2

Sketch of Patent

The sketch on the right shows the system determines a driver state is below. The Patent describes it as:

FIG. 3 is a flow diagram of a method 300 for driver management, according to one aspect. The method 300 may include receiving 302 a first speech segment of a driver of an autonomous vehicle at a first time and a second speech segment of the driver of the autonomous vehicle at a second time or merely receiving a speech segment of the driver. The method 300 may include tracking 304 a prior destination, a future destination, a route, a set of waypoints, etc., associated with the driver of the autonomous vehicle. The method 300 may include determining 306 an estimated state of the driver based on the one or more speech segments, the destination(s) or locations associated with the driver of the autonomous vehicle, and a calendar event associated with the driver of the autonomous vehicle, and controlling 308 operation of a vehicle system of the autonomous vehicle or a mobile device 160 based on the estimated state of the driver.

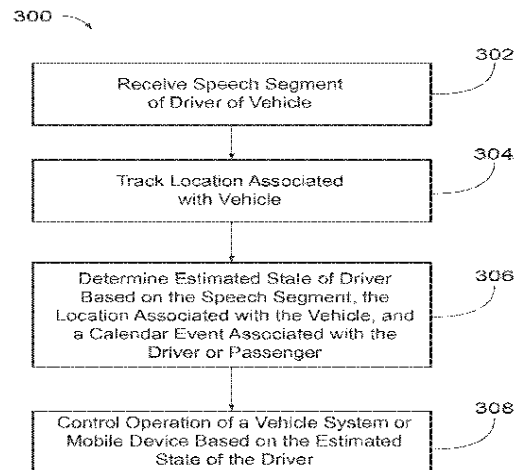

FIG. 3

The technology in this Patent which allows for Autonomous vehicle control based off of the driver's state is in development or developed by other Auto companies.

<sup>62</sup> "Management of autonomous vehicle driving features based on driver state," Honda. Patent US10789973B2. Filed August 28, 2018. <https://patents.google.com/patent/US10789973B2/en?q=10471969>

## 59. Hyundai Lane Keep Assist

The system, “helps you stay within your lane should you get distracted and start to swerve. This intelligent system uses a high-tech sensor in the windshield to scan the road ahead, constantly monitoring the lane markers both left and right of the vehicle. When activated, a visual and audible Lane Departure Warning will sound anytime the vehicle veers out of its lane. Additionally, the vehicle may apply slight pressure on the steering wheel, correcting your path before it strays further. The system deactivates when the turn signals are activated, to ensure no unnecessary alerts or warnings.”<sup>63</sup>

### More Information

- Video of technology: <https://youtu.be/hjzzuGY8ajU>

## 60. Hyundai Driver Attention Alert

The system works with a “windshield mounted camera continuously monitors the vehicle's position in the lane and analyses steering corrections and driving patterns to detect signs of fatigue, issuing a warning alert and visual advise the driver to take a break”<sup>64</sup>



The image on the right is from a Hyundai ad in New Zealand. The panel display shows the alertness level of the driver.

### More Information

- Video of technology: <https://vimeo.com/392373484>
- Ad of technology: <https://www.youtube.com/watch?v=nNxOJhRpooY>

<sup>63</sup> “Hyundai Lane Keep Assist,” AutoNation Hyundai Mall of Georgia.

<https://www.autonationhyundaimallofgeorgia.com/research/lane-keep-assist.htm>

<sup>64</sup> “Safety. Hyundai SmartSense,” Hyundai. <https://www.hyundai.com/au/en/why-hyundai/autonomous-driving/safety>

## 61. Hyundai

The DDREM (Departed Driver Rescue and Exit Maneuver) system monitors the driver via a camera. The system is developed by a Tier 1 company Hyundai Mobis. The system “uses camera sensors installed in the cabin to monitor the position of the driver’s head, line of sight, blinking speeds, and other identifiable physiological behavior.”



Images of Hyundai Mobis DDREM (YouTube)

It can measure a person’s head, blinking eyes. The test results are immediate. DDREM “system also continuously learns the baseline patterns of a normal driving condition for the driver, so it can distinguish between different driving states, and minimize false alarm.” It uses cameras and other advanced software and Autonomous Vehicle technology to take over control if the operator is incapacitated as shown from the images below.



The system was announced in 2018 by Hyundai’s Tier One supplier Hyundai Mobis. The technology is promoted in at least two places on the Hyundai’s OEM website. The technology is meant for drivers who are fatigued or having other medical conditions. The technology could take over for a driver unable to operate their vehicle.

### More Information

- October 16, 2019 video from Hyundai Mobis shows how the technology works: <https://www.youtube.com/watch?v=a7VU9e2TtVs&t=113s&fbclid=IwAR3b8wmBAjCkyFYlWcQBNQlwQTFhLxBsfkmFxslyb20srMhXOKdwpWbV7X4>
- “Hyundai Mobis develops ‘in-cabin systems’ utilizing the state-of-the-art autonomous driving sensors one after another!” March 24, 2020. <https://news.hyundaimotorgroup.com/MediaCenter/News/Press-Releases/Hyundai-Mobis-develops-in-cabin-systems-utilizing-the-state-of-the-art-autonomous-driving-sensors-one-after-another>
- “What if your car becomes a clinic?” March 26, 2020. Hyundai <https://news.hyundaimotorgroup.com/Article/What-If-Your-Car-Becomes-a-Clinic>.

## 62. Hyundai Patent: Health measurement system for vehicle's driver and warning method using the same

Hyundai/Kia Patent US10532658B2 filed in 2017 measures a driver's condition or state. The system provides "a health measurement system for a vehicle's driver and a warning method using the same, which can determine whether the driver has a healthy condition appropriate for vehicle driving by scanning a physical condition of the driver at a proper time, and can warn the driver of his or her abnormal health condition when the healthy condition of the driver is not found, thereby arousing a driver's attention in safe driving."<sup>65</sup>

The sketches below are taken from the Patent. **Figure 3** shows that the technology appears to show that the system could check the status of the health of the driver at the time the vehicle starts. **Figure 4** shows the system could check the health of the driver while the vehicle is moving. This Patent shows how Automakers are developing technology to monitor the health of drivers, which is important when it comes to autonomous vehicle technology.

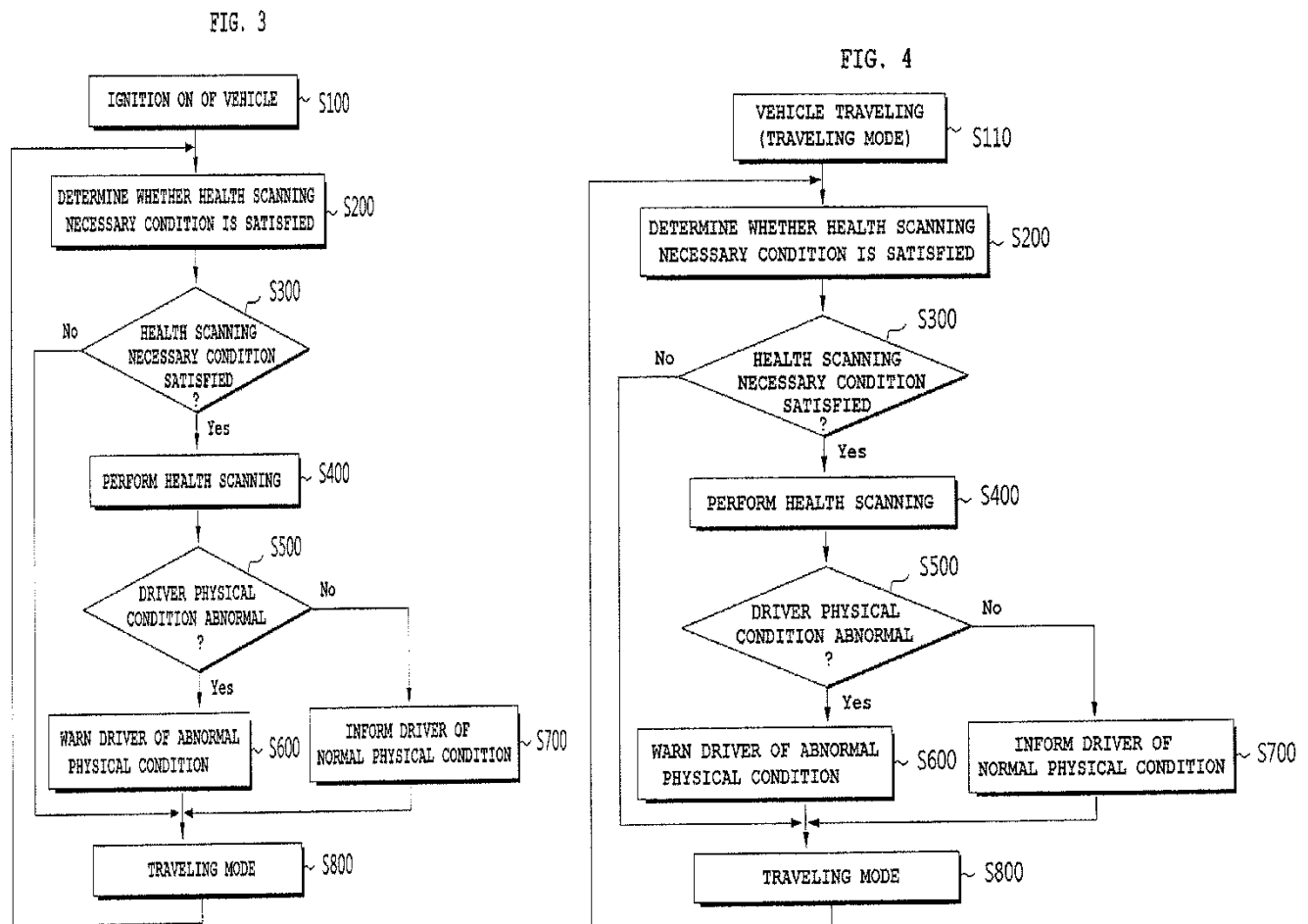

<sup>65</sup> "Health measurement system for vehicle's driver and warning method using the same," Hyundai/Kia. Patent US10532658B2. Filed December 28, 2017. <https://patents.google.com/patent/US10532658B2>

### 63. Hyundai Patent: Vehicle and method for supporting driving safety

Hyundai Patent US20190161091A1 filed in 2018 includes a driver monitoring system that monitors for brainwaves using a seat headrest. The system can determine a driver's drunken state based off of brainwaves. The technology intersects with autonomous vehicle technology as aims to determine the state or condition of the driver.

The Patent describes the sketches on the right of how a drunken state might look like based off of brainwaves:

As illustrated in FIG. 9, the brainwave signal based on the driver state may be determined by using the maximum amplitudes of the brainwave signals. **As described with reference to FIG. 8, the P300 potential component of the ERP has a feature of representing that the brainwave signal rises or increases after about 300 ms (a dotted rectangular part) if the normal reaction is made with respect to the auditory stimulation signal.** Referring to FIG. 9 based on the above feature, it may be recognized that a dotted curve and a solid curve have the maximum amplitudes after about 300 ms from that the stimulation starts.

**The dotted curve represents the brainwave signal of a driver in a normal state and the solid curve represents the brainwave signal of the driver in a drunken state.** As described above, the brainwave signals of the driver in the normal state and the drunken state have the maximum amplitudes after about 300 ms from that the abnormal stimulation starts.

**However, the brainwave signal of the driver in the drunken state is lower than the brainwave signal of the driver in the normal state in the maximum amplitude value.** Accordingly, it may be understood that the driver is more insensitive to the stimulation from the outside in the abnormal state rather than the normal state<sup>66</sup>

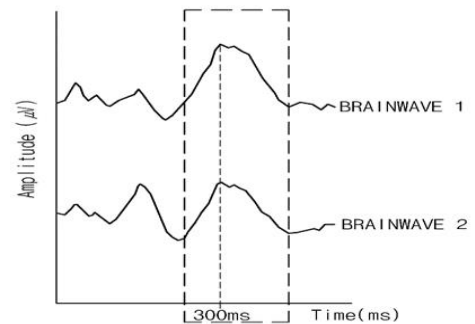

FIG. 8

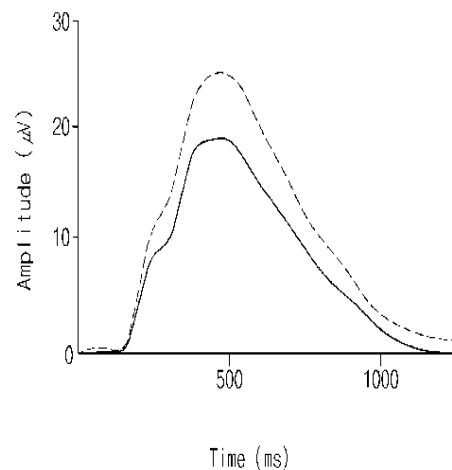

FIG. 9

It is unclear if the technology from this Patent is incorporated to other driver monitoring systems by Hyundai or if this will be incorporated with determining when a vehicle will go into autonomous driving mode based off the driver's state.

<sup>66</sup> "Vehicle and method for supporting driving safety thereof," Hyundai. Patent US20190161091A1. Filed July 2, 2018. <https://patents.google.com/patent/US20190161091A1>.

## 64. Hyundai Patent: System and method for determining state of driver

Hyundai/Kia Patent US10558875B2 filed in 2017 is for technology that monitors a driver's impaired state using cameras and other sensors. The Patent states it can determine "a state of a driver to determine his or her impaired state by determining his or her state based on his or her reflex response time according to behavior of a vehicle."<sup>67</sup>

As shown in the sketch below from the Patent and described throughout the technology, the Patent also involves Autonomous Vehicle driving technology depending on the driver's state:

If the present disclosure is applied to a fully autonomous vehicle or a partially autonomous vehicle and if it is determined that the driver is in the impaired state, the determination device 30 may adjust a time when control of the vehicle is transferred to the driver, may adjust a type of control transferred to the driver, or may make an emergency stop of the vehicle on a safety zone.

In other words, as shown in FIG. 4, if it is determined that the driver is in the impaired state by the driver state determination system 100, an autonomous driving control system 110 may adjust a time when control of the vehicle is transferred to the driver, may adjust a type of control transferred to the driver, or may make an emergency stop of the vehicle on a safety zone.

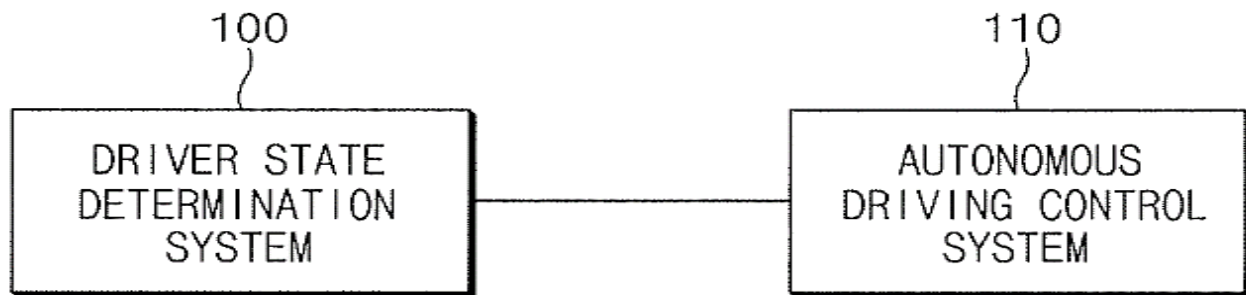

FIG. 4

The Patent is similar to other technologies in developed or development that can determine a driver's state and take over control of the vehicle if the driver is incapacitated.

---

<sup>67</sup> "System and method for determining state of driver," Hyundai/Kia. Patent US10558875B2. Filed November 6, 2017. <https://patents.google.com/patent/US10558875B2/en>

## 65. Hyundai and Cintalapa Technology Institute Alcohol Steering Wheel Sensors

Hyundai worked with Cintalapa Technology Institute in Mexico to develop a wheel based alcohol sweat sensor. The technology “can recognize blood alcohol content with steering wheel, transmission, and seat. The blood alcohol content usually requires drawing blood or spit, but these sensors can get the job done with sweat. The high level of blood alcohol content will prevent a driver from starting a car. It determines DUI without the interference of a driver who is unable to make rational decisions. This technology has been commercialized as the aftermarket product ‘AlcoStop’.<sup>68</sup>

Hyundai notes they showcased this technology at CES in 2014 and that heart rates will be able to tell a person’s impairment level “in the future, smart sensors will also be able to get specific blood sugar information and recognize DUI through electrocardiogram review.”

## 66. Infiniti Lane Departure Prevention

The system "helps keep your vehicle from unintentionally drifting from your lane. LDP uses a camera to monitor the distance between the vehicle and lane markings and, if the vehicle drifts towards the lane markers, the system first sounds a audible warning, followed by a selective application of the brakes to help move your vehicle back into its lane."<sup>69</sup>

The image on the right is from the Infiniti video of the technology.

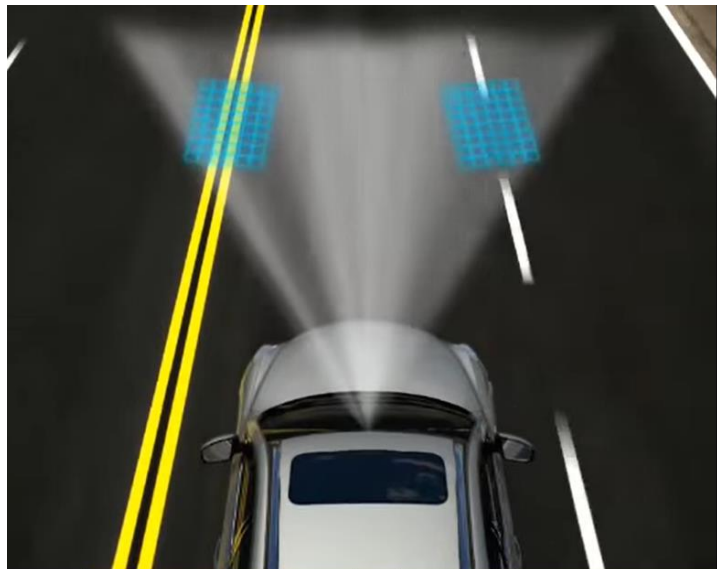

### More Information

- Video of technology: <https://youtu.be/4r6GDns0Dk>

---

<sup>68</sup> “What if Your Car Becomes a Clinic? Hyundai. March 26, 2020.

<https://news.hyundaimotorgroup.com/Article/What-If-Your-Car-Becomes-a-Clinic>.

<sup>69</sup> “Lane Departure Prevention,” Infiniti. <https://www.infiniti.com/infiniti-news/technology/lane-departure-prevention.html>

## 67. Jaguar Lane Departure Warning

The system “senses when your car is unintentionally drifting out of your lane and notifies you with a visual alert and a gentle vibration of the steering wheel.”<sup>70</sup>

### More Information

- Video of technology: <https://www.youtube.com/watch?v=Fc3S3lzqo8g>

## 68. Jaguar Lane Keep Assist

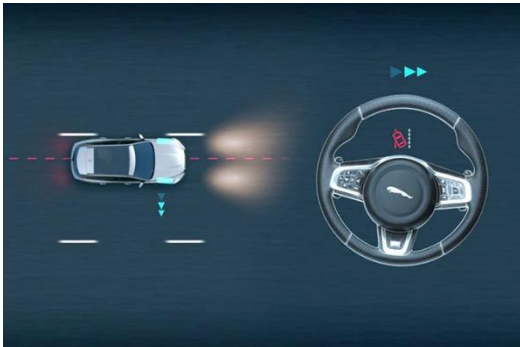

The system is slightly different than Lane Departure Warning because if the driver drifts out of their lane the “system will not only alert you to the problem, but also provide steering assistance to gently move you back into your lane.”<sup>71</sup> The image on the left is from Jaguar’s description of the technology.

### More Information

- Video of Technology: <https://www.youtube.com/watch?v=YXgCaC3JmQo>

## 69. Jaguar Driver Condition Monitor

The system “detects if you’re starting to feel drowsy and gives you an early warning when you need to take a break.”<sup>72</sup> The image below is from the Jaguar’s website describing the technology. The image on the right is from Jaguar’s description of the technology.

### More Information

- Jaguar Ad for technology: <https://www.youtube.com/watch?v=2Asw92Qf06Y>

---

<sup>70</sup> “Driving Features,” Jaguar. <https://www.jaguarusa.com/incontrol/incontrol/driver-assistance/index.html>

<sup>71</sup> “Driving Features,” Jaguar.

<sup>72</sup> “Driving Features,” Jaguar.



## 70. Jaguar Land Rover Driver Monitoring System

Jaguar Land Rover eye and head-based monitoring system is called simply a “Driver Monitor System.” The technology looks at a person’s eyes and analyzes a person head movement. It utilizes advanced software. The results seem to act immediately for driver inattention. Jaguar Land Rover’s website says “DMS is unique because it is the only driver monitoring system that can achieve this even if the driver is wearing shades, or in full sunshine.”<sup>73</sup> The Driver Monitor system also uses advanced computer software.

The website says “The algorithm we have developed for DMS has the potential to seamlessly enable a host of safety and autonomous driving features and reduce the potential for accidents caused by the driver not paying attention.”

The website, “DMS was developed at Jaguar Land Rover’s new R&D facility in Portland, Oregon, and while it was demonstrated in a Jaguar F-Type prototype, Nick Langdale-Smith, Vice President of Seeing Machines, believes the technology holds huge potential for other Land Rover vehicles.”

As the technology is still not fully available, the question will be whether users will have the option to turn off this feature if they get in on their vehicle.

## 71. Jaguar Land Rover Sixth Sense Project

Jaguar Land Rover’s “Sixth Sense Project” monitors brain waves and heart rate of driver by using sensors on the seat and steering wheel. The system uses seat-based sensors for heart and breathing ability. As this tech measures body, heart, and brain movement, it could also be programmed to determine substance impairment.

The system was announced as in development since 2015, it does not appear this technology has been incorporated into the vehicles. In the Driver Monitoring System space, other companies are looking into brain waves and also into using seats for monitoring the driver.

### More Information

- Jaguar Land Rover: <https://www.jaguarlandrover.com/news/2015/06/jaguar-land-rover-road-safety-research-includes-brain-wave-monitoring-improve-driver>
- “jaguar land rover reveals new road safety systems,” Top Speed. June 18, 2015. <https://www.topspeed.com/cars/car-news/jaguar-land-rover-reveals-new-road-safety-systems-ar170001.amp.html>

---

<sup>73</sup> “Jaguar Land Rover Unveil New Driver Monitor System That is Set to Revolutionise Road Safety,” Land Rover. <https://www.landrover.com/experiences/news/jlr-new-driver-monitor-system.html>

## 72. Land Rover Lane Keep Assist

The system is very similar to the Jaguar Lane Keep Assist as if a driver drift out of their lane, their “Land Rover will not only alert you to the problem, but steer you safely back into your lane.”<sup>74</sup>

### More Information

- Video of technology: <https://www.youtube.com/watch?app=desktop&v=wmAndvHINZU&t=153s>

## 73. Land Rover Driver Condition Monitor

Like the Jaguar Driver Condition Monitor, the system “detects if you’re starting to feel drowsy and gives you an early warning when you need to take a break.”<sup>75</sup>

The image below is from the video description of the technology from Land Rover. The problems with this system is that it can be turned off and only work at certain speeds.

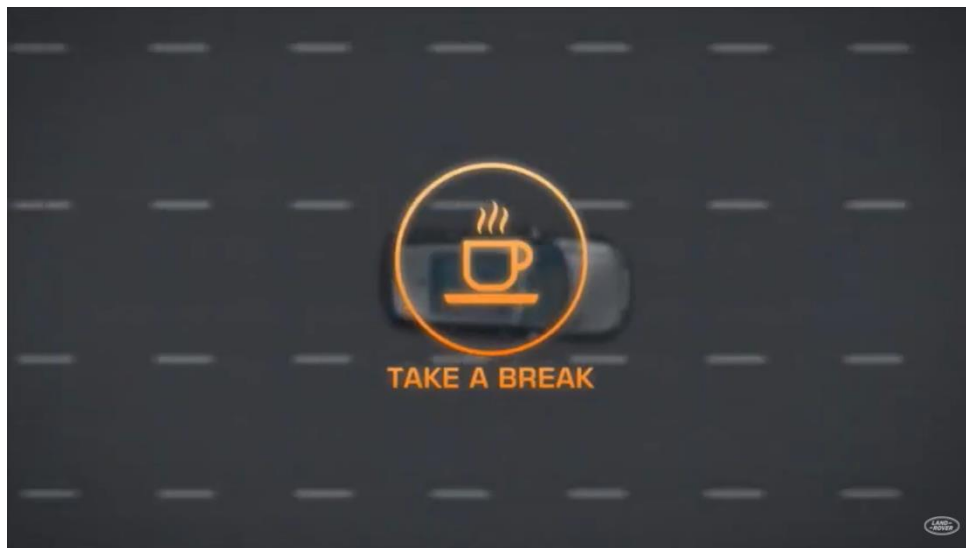

### More Information

- Video of technology: [https://www.youtube.com/watch?app=desktop&v=q2k12b18\\_08](https://www.youtube.com/watch?app=desktop&v=q2k12b18_08)

---

<sup>74</sup> “InControl Driver Assistance,” Land Rover. <https://www.landrover.com/ownership/incontrol/driver-assistance.html>

<sup>75</sup> “InControl Driver Assistance,” Land Rover.

## 74. Jeep LaneSense

Like the Dodge and Chrysler LaneSense systems, this technology “alerts you with visual and audible warnings during unintentional lane drifts and course corrects your vehicle back into its lane.”<sup>76</sup>

The system must be manually turned on if driver wants to use it and only works at certain speeds.

### More Information

- Video of technology: <https://www.youtube.com/watch?app=desktop&v=dOoicARrctM>

## 75. Jeep Active Driving Assist

According the video posted by the Automaker, if the vehicle crosses a lane boundary, a warning will appear in the Instrument Cluster, and the steering wheel will vibrate.

According to video of the system, “ the system detects driver inattentiveness – such as hands off the steering wheel – the instrument cluster display glow as well as the steering wheel icon will change from green... to yellow... to red to warn the driver.”



Above, is an image of the video of the technology. It shows how the Instrument Cluster looks when the driver is warned to pay attention.

### More Information

- Video of technology:  
<https://www.youtube.com/watch?app=desktop&v=m9B3Hb27K3U>

---

<sup>76</sup> “Cherokee Safety and Security,” Jeep. <https://www.jeep.com/cherokee/safety-security.html>.

## 76. Kia Lane Departure Warning

The system “provides audio and visual warnings from the screen, alerting the driver if they stray out of lane unintentionally.”<sup>77</sup> The image to the right is from a video description of the technology from Kia.<sup>78</sup> The vision based system uses advanced algorithms according to the video description.

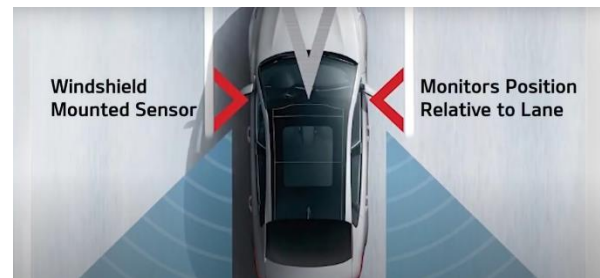

## 77. Kia Lane Keep Assist



The system, “alerts you and even steers you back into place to keep you exactly where you need to be.”<sup>79</sup> The image on the left is from Kia on the video description of the technology.

This system takes corrective action, whereas the Lane Departure Warning does not.

## 78. Kia Driver Attention Warning

The system “monitors the usual driving habits and behaviour of the driver. By understanding the driver's usual tendencies and driving pattern, DAW is able to detect irregularities in your driving which may be a sign of driver fatigue or a distracted driver. When the system detects these issues, it alerts the driver with visual and audio warnings. A coffee cup appears on the dashboard along with an audible alert to alert the driver that they are either driving carelessly or should consider taking a break from driving on longer drives.”<sup>80</sup> The image on the right is of the system.



### More Information

- Kia video of technology: <https://www.youtube.com/watch?app=desktop&v=3kY-fXwngRM>

<sup>77</sup> “Drive WiSE technologies,” Kia. <https://www.kia.com/eu/about-kia/experience-kia/technology/drive-wise/>

<sup>78</sup> “Kia Lane Keeping Assist-Line (LKA-L) & Lane Departure Warning (LDW),” Kia. <https://www.youtube.com/watch?v=1HoDvm1-QeY>.

<sup>79</sup> Drive WiSE technologies,” Kia.

<sup>80</sup> “Kia Safety Tech: Driver Attention Warning System (DAW)” Kia Victoria. December 22, 2020. <https://www.kiavictoria.ca/2020/12/22/kia-safety-tech-driver-attention-warning-system-daw/>

## 79. Lexus Lane Departure Alert

The system uses “an in-vehicle camera designed to detect visible white and yellow lane markers in front of the vehicle and the vehicle’s position on the road. If the system determines that the vehicle is starting to unintentionally deviate from its lane, the system alerts the driver with an audible and visual alert. When the alerts occur, the driver must check the surrounding road situation and carefully operate the steering wheel to move the vehicle back to the center part of their lane.”<sup>81</sup>

### More Information

Video of technology: <https://www.youtube.com/watch?v=VBYFz9DpV3U>

## 80. Lexus Lane Departure Alert with Steering Assist

The system uses an works “In addition to the alert function of Lane Departure Alert, certain vehicles with electronic power steering (EPS) will feature a Steering Assist function. When equipped and enabled, if the system determines that the vehicle is on a path to unintentionally depart from its lane, the system may provide small corrective steering inputs to the steering wheel for a short period of time to help the driver keep the vehicle in its lane.”<sup>82</sup>

### More Information

Video of technology: <https://www.youtube.com/watch?v=-jBPzhyQyg>

## 81. Lexus Driver Attention Monitor

An article describes “Buyers opting for the Advanced Pre-Collision package will also get a driver attention monitor which can detect drowsy drivers.”<sup>83</sup>

### More Information

- Video of technology being tested: <https://www.youtube.com/watch?v=O5fZKGEp6DA>

---

<sup>81</sup> “Lexus Safety System+,” Lexus. <https://drivers.lexus.com/lexus-drivers-theme/pdf/LSS+%20Quick%20Guide%20Link.pdf>

<sup>82</sup> “Lexus Safety System+,” Lexus.

<sup>83</sup> “Lexus LS,” CNET. <https://www.cnet.com/roadshow/make/lexus/model/ls/>

## 82. Lexus

Lexus has an eye and face camera-based Driver Monitoring System.

The image on the right from a YouTube video description of the technology.

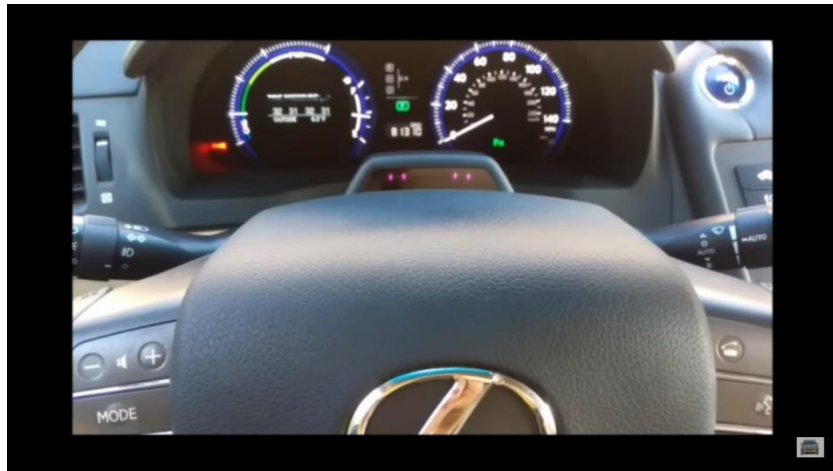

### More Information

- Video of the technology from YouTube:  
<https://www.youtube.com/watch?v=7MommnELwwM>

## 83. Lexus

Lexus, owned by Toyota, has a system called the “Preventative Safety Package.” If driver is unable to operate the vehicle, vehicle stops moving. The system appears to measure for sudden changes of driver behavior and can stop the vehicle and call for help. The system can sense if the driver is unable to operate the vehicle and pull over the vehicle safely. The type of sensors it uses are unclear, but they must monitor the driver in order to take control of the vehicle.

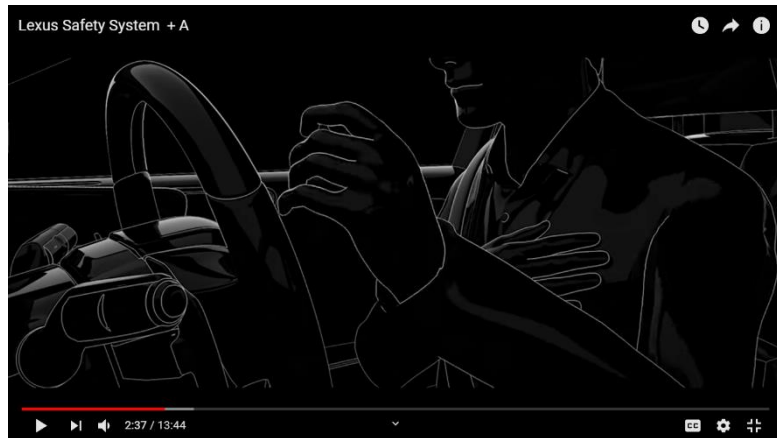

**Lexus Safety System +A  
(YouTube)**

Lexus must think highly of this technology as it is on their website. The technology takes over the vehicle and it is unclear if the feature can be disabled.

### More Information

- Lexus: <https://lexus.jp/technology/safety/>
- This Lexus Video shows how the system operates around minute 2:30:  
<https://youtu.be/7oAR7hV2JPA>

## 84. Lincoln Lane Keeping System

The technology uses “camera mounted behind the windshield’s rear view mirror to monitor road lane markings and detect unintentional drifting toward the outside of a lane. If the camera detects an impending unintentional drift, the system will use the steering system and the instrument cluster display to alert and/or aid you to stay in your lane.”<sup>84</sup>

### More Information

- Video of technology: [https://www.youtube.com/watch?app=desktop&v=35HDM\\_Yvq\\_Y](https://www.youtube.com/watch?app=desktop&v=35HDM_Yvq_Y)

## 85. Mazda Lane Departure Warning System

The system “detects line marking on the road surface and warns the driver of unintentional lane departures. This system is particularly effective in situations where the road is continuously straight and drivers have a tendency to not pay sufficient attention to the road. When the lane change is accompanied by turn signal operation or acceleration, the system recognizes the maneuver as intentional and does not sound an alarm.”<sup>85</sup>

## 86. Mazda Lane Keep Assist System

The technology “allows drivers to choose between Lane-Trace, which provides steering assistance early in order to help keep the vehicle centered in the lane and Lane Departure Avoidance, which only comes into play if the vehicle begins to leave its lane. LAS uses a windshield-mounted camera to recognize lane-markings on the road and activates at speeds above 60 km/h.”<sup>86</sup>

## 87. Mazda Driver Attention Alert

The system “comes into play at speeds above 65 km/h and begins to “learn” the driver’s habits, watching inputs and the vehicle’s movements in the early stages before fatigue is a factor. Later, if the system detects changes in vehicle behavior that suggest the driver may be losing concentration, it will suggest a rest stop by sounding a chime and displaying a warning in the Multi-Information Display”<sup>87</sup>

### More Information

- Video of technology: <https://www.youtube.com/watch?app=desktop&v=WsOEud74rkc>

---

<sup>84</sup> “Lane Keeping System,” Lincoln. <https://owner.lincoln.com/support/how-tos/safety/driver-assist-technology/driving/how-to-use-lane-keeping-system.html#>

<sup>85</sup> “Lane Departure Warning System,” Mazda.

[https://www.mazda.com/en/innovation/technology/safety/active\\_safety/ldws/](https://www.mazda.com/en/innovation/technology/safety/active_safety/ldws/)

<sup>86</sup> “Lane Keep Assist System,” Mazda.

[https://www.mazda.com/en/innovation/technology/safety/active\\_safety/las/](https://www.mazda.com/en/innovation/technology/safety/active_safety/las/)

<sup>87</sup> “Driver Attention Alert,” Mazda. [https://www.mazda.com/en/innovation/technology/safety/active\\_safety/daa/](https://www.mazda.com/en/innovation/technology/safety/active_safety/daa/)

## 88. Mitsubishi Lane Departure Warning

The technology described in 2019 “uses an onboard camera to monitor the lane in front of you. If it detects your vehicle unintentionally drifting from its path, it sends both visual and audible alerts. It comes standard in all vehicles except the Mirage and Mirage G4.”<sup>88</sup>

### More Information

- Video of technology: <https://www.youtube.com/watch?app=desktop&v=UQ4TNnPbfOU>

## 89. Mitsubishi Driver Attention Alert

The system is “only a warning to inform the driver of a potential lack of driver attention or drowsiness. It will not steer the vehicle or prevent loss of control. The DAA system does not detect or provide an alert in every situation.”<sup>89</sup>

The system seems to be part of Mitsubishi’s new Mi-Pilot Assist too.<sup>90</sup>

## 90. Nissan Intelligent Lane Intervention

The technology works “If there is a risk of leaving the driving lane, the system displays an alert on the dashboard and plays a warning chime. The system also assists the driver

to avoid leaving the driving lane by applying the brakes.”<sup>91</sup> The image above is from the Nissan website description of the technology.

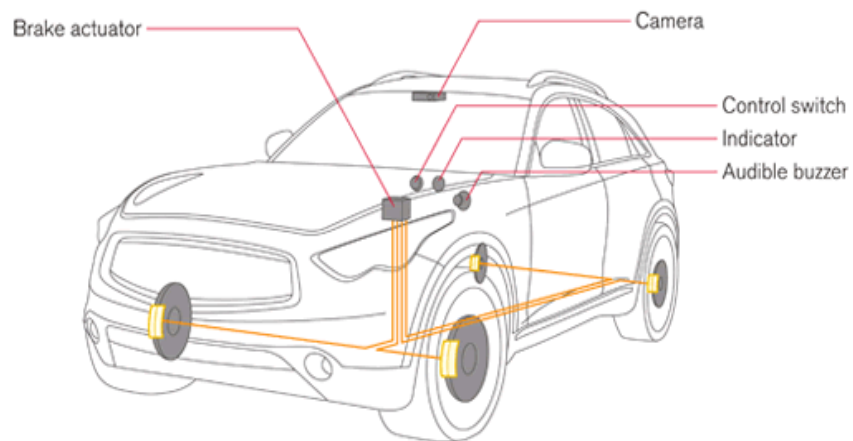

### More Information

Video of technology: <https://youtu.be/kedw8MWzcwQ>

<sup>88</sup> “Mitsubishi Safety Features For 2019,” University Mitsubishi. April 11, 2019.

<https://www.universitymitsubishi.com/mitsubishi-safety-features-for-2019/>

<sup>89</sup> “Advanced Safety Features Disclaimers,” Mitsubishi Canada. <https://www.mitsubishi-motors.ca/en/advancedsafety>

<sup>90</sup> “What is Mitsubishi Mi-Pilot Assist?” JD Power. February 22, 2021. <https://www.jdpower.com/cars/shopping-guides/what-is-mitsubishi-mi-pilot-assist>

<sup>91</sup> “Intelligent Lane Intervention,” Nissan. <https://www.nissan-global.com/EN/TECHNOLOGY/OVERVIEW/ili.html>.



## 91. Nissan Lane Departure Warning

The technology “visually monitors the left and right side lane markers of the traveling lane. If there is a risk of the vehicle leaving the traveling lane unintended, the system flashes an indicator and sounds a warning chime.”<sup>92</sup> The image below is from the Nissan website describing the technology.

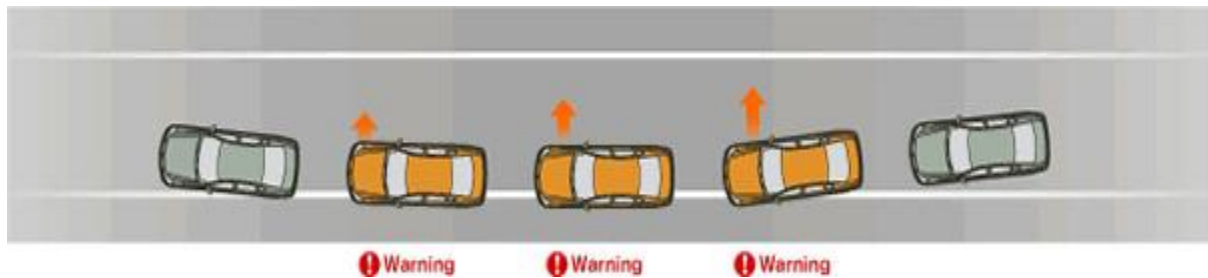

### More Information

- Video of technology: <https://youtu.be/wbwKLhpr8Fc>

## 92. Nissan Driver Attention Alert System

The system works by “Using steering angle sensors, DAA monitors steering input patterns to establish a baseline or a “snapshot” of how you were driving. Then, it continuously compares subsequent driving patterns to the most recent snapshot using a statistical analysis of steering corrections.” The technology “includes logic to help address false detections such as lane changes, braking events, and even poor road conditions. It’s even smart enough to know when you may be drowsy, and also know when your driving patterns have to be adjusted to fit the circumstances.”<sup>93</sup>

### More Information

- Nissan Ad for technology: <https://global.nissannews.com/en/videos/video-2f7966f516e271fc4ea0f79a9a02934d-new-driver-attention-alert-system-offered-on-maxima-and-murano>
- Video of technology: <https://www.youtube.com/watch?v=0INROdtwSwU>

---

<sup>92</sup> “Lane Departure Warning,” Nissan. <https://www.nissan-global.com/EN/TECHNOLOGY/OVERVIEW/ldw.html>

<sup>93</sup> “Driver Attention Alert System,” Nissan. June 15, 2015. <https://www.nissanusa.com/experience-nissan/news-and-events/drowsy-driver-attention-alert-car-feature.html>

## 93. Nissan Pro-Pilot 2.0

### Methods and systems

The Nissan ProPilot 2.0 measures for driver attention using a camera and also measures outside conditions. The system is a driver-facing camera that tracks eyes and head. The results are immediate. The image below is from Nissan's website of the technology.



The technology appears to be an option on certain Nissan vehicles for sale in the World. It is not clear if the driver can disable the system.

### More Information

- Nissan: <https://www.nissan-global.com/EN/TECHNOLOGY/OVERVIEW/ad2.html>
- Nissan ProPILOT 2.0 driver monitoring system confirms the driver is attentive: <https://global.nissannews.com/en/photos/photo-bafd61da591f6a12b93336e84540019ad-propilot-20-driver-monitoring-system-confirms-the-driver-is-attentive>
- Nissan Reveals Revolutionary Hands-Off Self-Driving Tech, Forbes. July 23, 2019. <https://www.forbes.com/sites/peterlyon/2019/07/23/autonomous-driving-war-heats-up-as-nissan-launches-revolutionary-self-driving-tech/?sh=2e4f41407fc3>

## 94. Nissan alcohol sensors driver monitoring

In 2007, Nissan announced a concept vehicle that could detect alcohol-impaired driving by using sensors such as odor detectors as well as facial recognition of the driver via a camera all while monitoring any erratic driving of the vehicle operator.

When an alcohol odor would be detected via the gear shift knob or breath sensor on the seat, the driver would be notified. The camera system worked in the following way:

A camera is mounted on the instrument cluster facing the driver to monitor the driver's face. The system is calibrated to monitor the driver's state of consciousness through the blinking of the eyes. When the system detects signs of drowsiness, a voice and message alert is triggered via the navigation system. Additionally, a seat-belt mechanism is activated which tightens around the driver to gain his or her immediate attention.<sup>94</sup>



Above are images from Nissan of camera and facial recognition. According to the 2007 press release, Nissan was looking into reducing drunk driving

Nissan has already launched and is developing several initiatives to help prevent drunk driving. In June, the company introduced the "drunk driving" message alert on its navigation system. In July, Nissan also began testing of a new on-board breathalyzer system in cooperation with several local government authorities, where an interlock mechanism will immobilize the vehicle if the driver's breath indicates the presence of alcohol above a specified level.<sup>95</sup>

It is unclear what happened with the Nissan project or if the company has incorporated driver monitoring using a camera into other technologies.

### More Information

- Video of technology: <https://www.youtube.com/watch?v=dV9LfD1CYhI>

<sup>94</sup> "Concept Car to showcase Anti-Drunk Driving Technology," Nissan. August 3, 2007.

<https://global.nissannews.com/en/releases/release-95e86dba49c0e8277e3c7b662e6aac68-070803-02-e>

<sup>95</sup> "Concept Car to showcase Anti-Drunk Driving Technology," Nissan.

## 95. Porsche Lane Keeping Assist

The system is a “camera-based system for automatic detection of divider line markings on the road. The system eases the burden on the driver by providing steering assistance, helping to keep the vehicle in lane.”<sup>96</sup>

### More Information

- Ad for technology: <https://www.youtube.com/watch?v=6MWRg3khSAs>
- Video of technology: <https://www.porsche.com/usa/accessoriesandservices/porscheservice/vehicleinformation/imanuals/~vf~/Lane-Change-Assist-2020-911/multimedia~en~porsche-imanuals-lanechangeassist-2020911/>

## 96. PSA Groupe Lane Keeping Alert and Lane Keeping Assist

The system “warns the driver and corrects the path if the vehicle is about to cross the line without indicating.”<sup>97</sup>

## 97. Seat Lane Assist

The technology works in the following way:

The driver's steering activities are continuously analysed by the Lane Assist warning. If the system detects that the driver takes his hands off the wheel, a warning is issued in the multifunction display. The steering intervention is suppressed when the driver actively leaves the lane (with and without blinker as well as overtaking on country roads). If the field of vision of the camera is fogged up during the operation, for example in a humid environment or with wet weather conditions, a specially developed heater of the field of view switches on for the lane departure warning. The field of vision is thus quickly released from fog and the detection of the lane markings is guaranteed.<sup>98</sup>

### More Information

- Video of technology: <https://youtu.be/b6pHA5xTQBQ>

## 98. Seat Travel Assist

The system “combines Adaptive Cruise Control and Lane Assist at the touch of a button. And warns you when detecting your hands are not on the wheel.”<sup>99</sup>

## 99. Seat Emergency Assist

The technology works “Should the driver become unresponsive, Emergency Assist slows the car down while warning the driver.”<sup>100</sup> Other automakers have designed other similar technology.

---

<sup>96</sup> “Lane Keeping Assist,” Porsche. <https://www.porsche.com/china/en/models/panamera/panamera-models-1/panamera-10years/assistance-systems/lane-departure-warning/>

<sup>97</sup> “LAB: 50 years at the service of Road Safety,” PSA Groupe

<sup>98</sup> “Lane Assist,” Seat. <https://www.seat.com/car-terms/l/lane-assist.html>

<sup>99</sup> “Taking the Stress out of Driving,” Seat. <https://www.seat.com/carworlds/new-ateca/safety.html>.

<sup>100</sup> “Taking the Stress out of Driving,” Seat.

## 100. Seat

Seat, owned by Volkswagen, is working with Cipia (formerly EyeSight) in deploying driver monitoring in vehicles.

The Cipia system uses artificial intelligence and driver monitoring for a person's head and eye movement. The website says, "Eye openness, angle of vision, head position... An algorithm analyses the actions of the driver and warns them in the event of distraction or drowsiness. It also detects mobile phone use and whether the seatbelt is fastened."<sup>101</sup>

Cipia is paired up with many Tier 1 suppliers and other companies and this technology is moving along quickly. It is unclear how the technology will be implemented in vehicles. The image below is from a video on the technology from Seat.

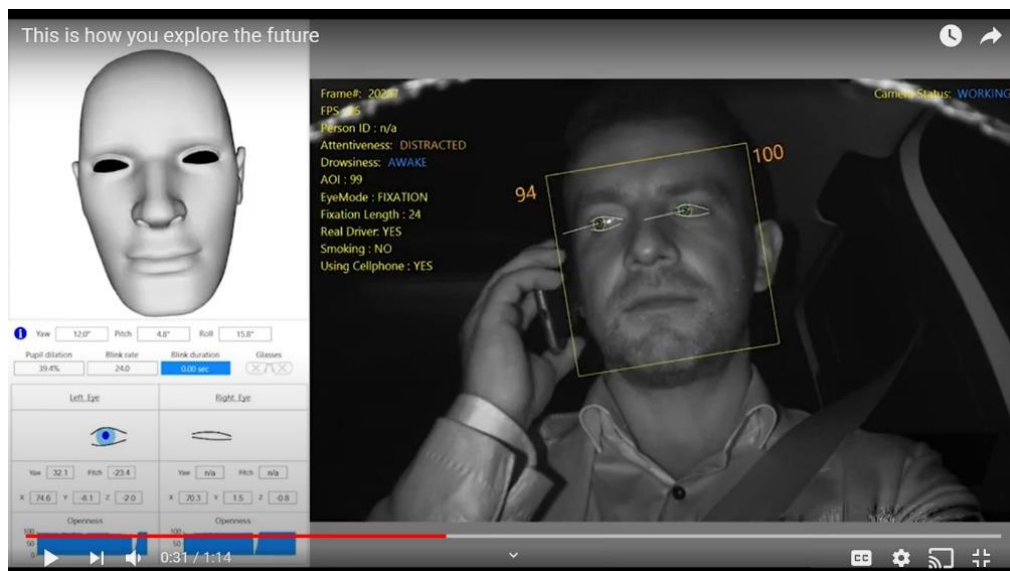

### More Information

- Video of technology: [https://youtu.be/\\_pXil4LeGk](https://youtu.be/_pXil4LeGk)

<sup>101</sup> "This is how we explore the future," Seat. February 17, 2020.  
<https://www.seat.com/company/news/company/xplora-the-future.html>

## 101. Subaru EyeSight

Among other features, this technology “monitors your position on the road and will alert you if you stray out of your lane”<sup>102</sup> The technology can correct the vehicle if it sways out of the lane.

Eyesight technology has been sold on over 1 million vehicles and has been found to reduce rear-end crashes by 85 percent.<sup>103</sup>

### More Information

- Video of technology: <https://www.youtube.com/watch?v=1KAW5fphNL4>

## 102. Subaru Driver Focus

The Subaru “Driver Focus” or “Driver Monitoring System” monitors head and eye movement for fatigue and distraction. The driver-facing camera will track eye gaze and head position. It gives an immediate alert for fatigue or distraction. The car will not slow down or stop if the alert goes off. The advanced optical sensors look at head movement and the opening of the eyes. The image above is from an Ad for the technology.



### More Information

- Subaru Driver Focus: [https://www.subaru.com/guides/forester/my19/content/driver\\_focus.html](https://www.subaru.com/guides/forester/my19/content/driver_focus.html)
- “What is Subaru DriverFocus Technology?” JD Power. June 25, 2020. <https://www.jdpower.com/cars/shopping-guides/what-is-subaru-driverfocus-technology>
- “Subaru DriverFocus: Most Innovative New Safety or Driving Aid” Edmunds. February 26, 2019. <https://www.youtube.com/watch?v=vwJQ2HeXq7M>
- “Subaru DriverFocus Technology” October 5, 2018. <https://www.youtube.com/watch?v=T2fZCSZK710>
- “Subaru Driver Monitoring System” August 27, 2019. <https://www.youtube.com/watch?v=BDAILNxqB6M>

<sup>102</sup> “EyeSight Driver Assist Technology,” Subaru. <https://www.subaru.com/engineering/eyesight.html>

<sup>103</sup> EyeSight Driver Assist Technology,” Subaru.

### 103. Tesla Autopilot: Auto Lane Change

The technology utilizes “8 external cameras, a radar, 12 ultrasonic sensors and a powerful onboard computer provide an additional layer of safety to guide you on your journey.” The Auto Lane Change feature “assists in moving to an adjacent lane on the highway when Autosteer is engaged.”<sup>104</sup>

More Information

- Ad for technology: <https://www.youtube.com/watch?v=PUbk2Ko-VU4>

### 104. Tesla Lane Departure Avoidance

The system works when the system is not in Autopilot. The system

Lets a driver elect to have corrective steering applied in order to keep them in their intended lane. When the feature is in use and a driver is departing a lane without their turn signal on, the car will also check to see whether a driver’s hands are on the wheel. If a driver’s hands are not detected on the wheel, the driver will receive a series of hands-on reminders and alerts, similar to the ones that our cars provide to customers who use Autopilot. If a driver's hands are repeatedly not detected on the wheel when Traffic Aware Cruise Control is in use, their car will gradually slow down to 15 miles below the speed limit or below the car’s set speed and turn its hazard lights on.

This feature can be turned on or off, and works at speeds between 25 and 90 mph. It is an extension of Lane Departure Warning, which already warns drivers through a steering wheel vibration if they begin to drift out of their lane without their turn signal engaged.<sup>105</sup>

### 105. Tesla Emergency Lane Departure Avoidance

The system “Emergency Lane Departure Avoidance is designed to steer a Tesla vehicle back into the driving lane if our system detects that it is departing its lane and there could be a collision, or if the car is close to the edge of the road. This feature will automatically be enabled at the beginning of every drive, but can be turned off for a single drive by going to the Autopilot Controls menu.”<sup>106</sup>

### 106. Tesla Driver Monitoring System

Tesla does have vehicles with driver facing cameras. These are not currently used as a feature to monitor a driver. However, Tesla does monitor the driver using the steering wheel and seat.<sup>107</sup> A recent video of the system does actively monitor the eyes of the driver and distractions was recently posted online which shows how the system works.<sup>108</sup>

---

<sup>104</sup> “Support,” Tesla. <https://www.tesla.com/support/autopilot>.

<sup>105</sup> “More Advanced Safety for Tesla Owners,” Tesla. May 2, 2019. [https://www.tesla.com/en\\_EU/blog/more-advanced-safety-tesla-owners?redirect=no](https://www.tesla.com/en_EU/blog/more-advanced-safety-tesla-owners?redirect=no)

<sup>106</sup> “More Advanced Safety for Tesla Owners,” Tesla. May 2, 2019.

<sup>107</sup> “Tesla Kicking Inattentive Drivers Off “Full Self Driving” Beta Testing,” Motortrend. April 15, 2021. <https://www.motortrend.com/news/tesla-full-self-driving-beta-testers-being-rejected-inattention/>

<sup>108</sup> “Watch Tesla’s driver monitoring system detect driver attention in real time,” Electrek. April 8, 2021. <https://electrek.co/2021/04/08/tesla-driver-monitoring-system-detect-driver-attention-real-time/>

## 107. Toyota Lane Departure Alert

The system has a “camera on your windshield may help you avoid the consequences of unintended lane departure by alerting you when it senses that you've veered from your lane.”<sup>109</sup>

### More Information

- Video of technology: <https://youtu.be/Bu86mosqVDU>
- Video of technology: <https://www.youtube.com/watch?v=kQgVWq1cb5w>

## 108. Toyota Lane Departure Alert with Steering Assist

The system will alert you with an audible beeping sound and indicator light on the instrument panel will flash so that you can then take corrective action. Should the system determine that the driver is not taking corrective steering action, the Steering Assist function will initiate and provide gentle corrective steering when necessary to help keep the vehicle in the lane.”<sup>110</sup>

### More Information

- Video of technology: <https://www.youtube.com/watch?v=2Ps9hwkZ-go>

## 109. Toyota Lane Tracing Assist

The system works “when Dynamic Radar Cruise Control is enabled and lane markers are visible, Lane Tracing Assist uses the lines on the road and preceding vehicles to help keep the vehicle centered and in its lane.”<sup>111</sup>

### More Information

- Video of technology: <https://www.youtube.com/watch?v=QVyRsdILbRw>

---

<sup>109</sup> “Toyota Safety Sense: The Standard for Safety,” Toyota. <https://www.toyota.com/safety-sense/animation/lda>

<sup>110</sup> “Toyota Safety Sense,” Toyota of La Crosse. <https://www.toyotaoflacrosse.com/toyota-safety-sense.html>

<sup>111</sup> “Toyota Safety Sense: The Standard for Safety,” Toyota. <https://www.toyota.com/safety-sense/animation/lta>



## 110. Toyota driver monitoring system

This driver monitoring system monitors the eyes and head. The system detects the eyes and lower eyelids, calculating how open are the eyes. The system also looks if driver is facing forward and can detect distracted or drowsy drivers. The results of the tests are immediate. The systems uses a system of cameras and other sensors.

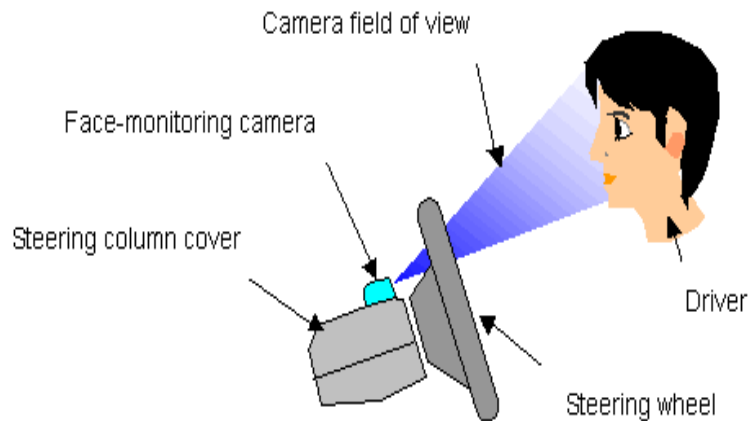

The image on the right and below is a driver monitoring configuration from Toyota from 2005 and 2008.

The technology was announced in 2006 and was announced again in 2008. It is unclear if the cameras are an option on Toyota vehicles.

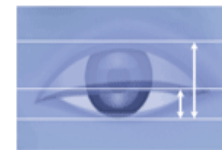
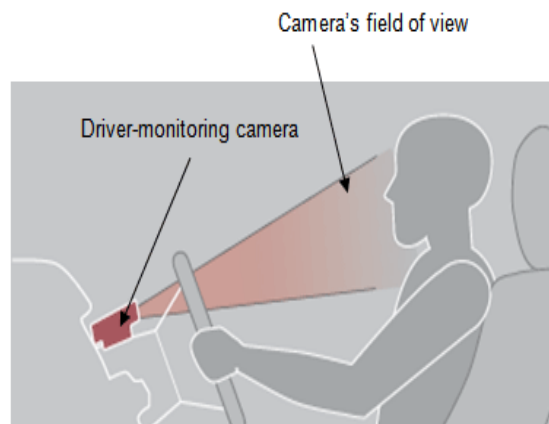

Detects the upper and lower eyelids, calculating how open the eyes are.

### More Information

- Toyota Enhances Pre-crash Safety System With Driver-monitoring Function," September 6, 2005. Toyota. <https://global.toyota/en/detail/248128>.
- "Toyota Enhances Pre-crash Safety System with Eye Monitor," January 22, 2008. Toyota. <https://global.toyota/en/detail/281564>

## 111. Toyota Heart based monitor

If driver is unable to operate vehicle, vehicle stops moving. The system measure uses heart rate using sensors. A researcher on the project says “Our goal is to help inform the development and adoption of in-vehicle cardiac monitoring systems, which we believe can help reduce the number of traffic accidents and save lives.” The technology would interact with the driver. According to a researcher on the project, the goal is to “install cardiac sensors directly into vehicles so that the car itself would have the capacity to detect a heart anomaly. If detected, the vehicle could attempt to warn the driver or, if the driver was unresponsive, in conjunction with other technology under development, it could pull over, stop the car and summon help.”<sup>112</sup>

The image on the right is from a Toyota press release on the technology.

Heart related changes can be indicative of impairment. The sensor might be able to pick up on other health problems and impaired driving.

Lexus is rolling out similar technology and other companies are looking into technology that monitors a person’s heart and a driver’s physical state.

The Lexus models of Toyota seem to be incorporating this technology as an option on their vehicles.

### More Information

- “Toyota Driver Monitoring Sensors Could Detect Heart Trouble.” DesignNews, October 28, 2020. <https://www.designnews.com/automotive-engineering/toyota-driver-monitoring-sensors-could-detect-heart-trouble>

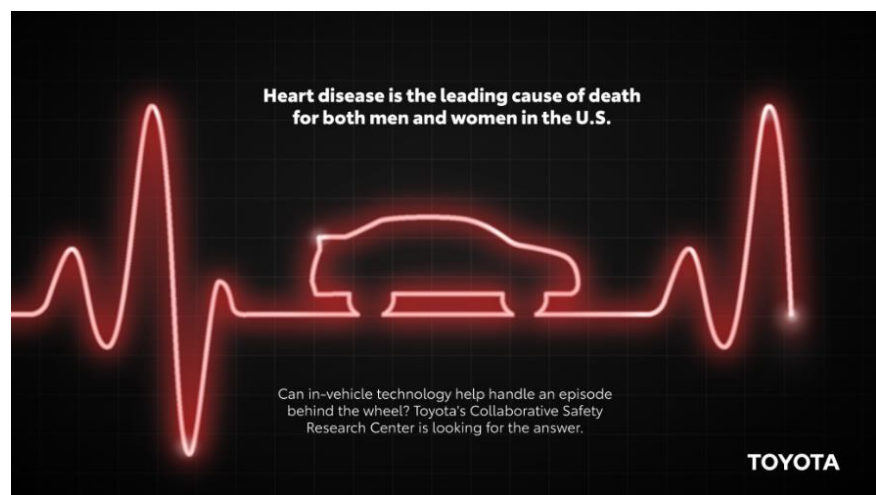

---

<sup>112</sup> “Making Roads Safer by Detecting Driver Heart Anomalies,” Toyota. <https://pressroom.toyota.com/making-roads-safer-by-detecting-driver-heart-anomalies/>

## 112. Toyota Patent: Vehicle emergency evacuation device

Toyota Patent US8954238B2 filed in 2011 is for technology that measures drivers' condition while driving and stops the vehicle. The patent says the technology "is described to detect a driver's consciousness lowering (a symptom of napping) by measuring a driver's heart rate, a time period without steering, a time period without blinking, etc. (through monitoring a driver's face with a camera) and to execute an automatic vehicle stop when the driver's consciousness lowering repeatedly occurs even if the driver is prompted to awake."<sup>113</sup>

The patent says the technology can measure consciousness, heart rate, face, eyes, which could all show signs of substance impairment. The results of the driver monitoring system appear to be immediate. The system uses camera and other sensors.

This feature appears to be an option on Lexus vehicles and Toyota is researching this technology as of 2020. Toyota has researched it since at least 2011. There appears to be a market for technology that monitors heart rate as major auto companies are researching this technology (Toyota, Jaguar Land Rover, Hyundai).

## 113. Toyota Patent: Driving consciousness estimation device

Toyota Patent US10640122B2 filed in 2017 says "The driver monitor camera is provided on a cover of a steering column of a vehicle and in front of the driver, and images a head of the driver. Since the driver monitor camera images the driver from plural directions, plural number of cameras may be provided. The driver monitor camera it transmits a driver image in which the driver is imaged to the ECU 20."<sup>114</sup>

The technology also measures a driver's "readiness" stating "The driving readiness estimation unit 25 estimates a driving readiness relating to the driving consciousness of the driver." The technology can also measure the brainwaves and heart rate of the user.

The tests would be immediate through the camera. The technology also seems to work with autonomous vehicle technology.

The driver state monitoring technology put forward in this Patent are similar to the Patent from Toyota in 2011 (US8954238B2) in the sense that it can determine a driver's state. Lexus is incorporating driver state monitoring. The technology appears to put the vehicle in autonomous driving mode if a driver is determined unfit to operate a vehicle.

---

<sup>113</sup> "Vehicle emergency evacuation device," Toyota. Patent US8954238B2. Filed July 11, 2011. <https://patents.google.com/patent/US8954238B2>

<sup>114</sup> "Driving consciousness estimation device, Toyota, National Institute of Advanced Industrial Science and Technology AIS. Filed April 4, 2017. <https://patents.google.com/patent/US10640122B2>

## 114. Toyota

Announced in 2007 and mentioned in news reports, this system monitors a driver's alcohol level through a steering wheel sensor and also uses a camera to see if a driver's pupils are dilated.

The system was mentioned in 2007 and forms of the technology have been developed by other auto companies and technology companies.

### More Information

- "Toyota creating alcohol detection system," Associated Press. January 3, 2007. [http://www.nbcnews.com/id/16449687/ns/technology\\_and\\_science-innovation/t/toyota-creating-alcohol-detection-system/#.XZ52cVVKjIU](http://www.nbcnews.com/id/16449687/ns/technology_and_science-innovation/t/toyota-creating-alcohol-detection-system/#.XZ52cVVKjIU)

## 115. Toyota Patent: Vehicle Control Device

Toyota Patent filed in 2018 is for technology that monitors speech and utilizes other sensors that can determine if the driver is under the influence of alcohol. Below are images from the Patent.

The Patent says about the speech recognition:

According to the vehicle control device of the first aspect, in a case in which it is determined that the driver is in the intoxicated state based on the speech data, the start operation of the vehicle is limited. Here, the start operation is an operation performed by the driver with respect to the vehicle to start driving the vehicle. **Therefore, according to the vehicle control device of the first aspect, in a case in which the driver is in the intoxicated state, the start operation of the vehicle is limited, and thus, intoxicated driving may be prevented.**<sup>115</sup>

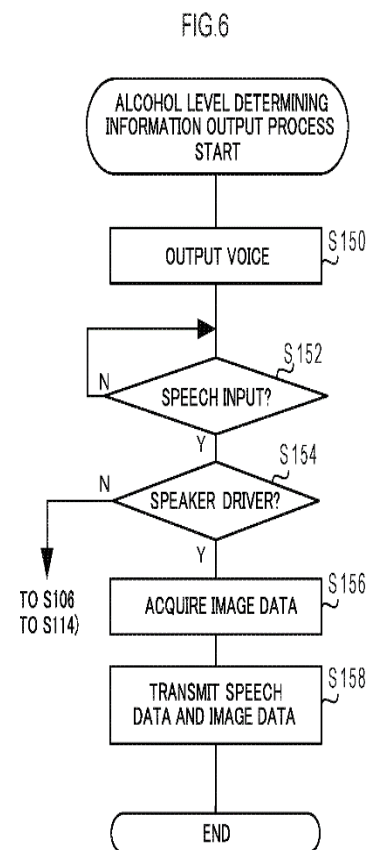
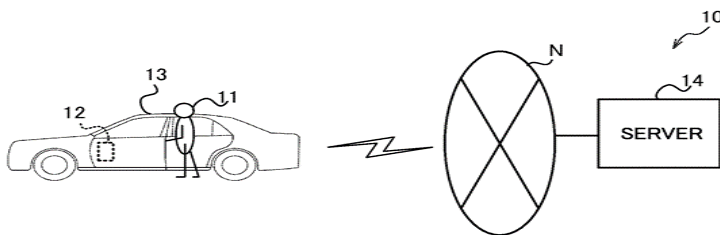

<sup>115</sup> "Vehicle control device, vehicle control method, and non-transitory computer readable medium storing vehicle control program," Toyota. Patent US20190210607A1. Filed December 28, 2018. <https://patents.google.com/patent/US20190210607A1>

## 116. Toyota Patent: Impairment evaluation system

Toyota Patent filed in 2015 is for speech and camera-based sensors for alcohol or other types impairment. The image on the right is an image from the Patent. Specially, the Patent notes the:

The system further includes an impairment event unit. The impairment event unit compares the operation of the vehicle with the sober driver profile after the motor vehicle stop. The impairment event unit identifies the motor vehicle stop as an impairment event when the operation of the vehicle deviates a predetermined amount from the sober driver profile. Accordingly, an impairment event, as used herein, relates to an event which impairs the driver's ability to operate the vehicle. Factors which the impairment event unit may consider include the braking profile, turning profile, traffic speed, acceleration, and lane departure. **The impairment may be a result of alcohol or drug consumption.**

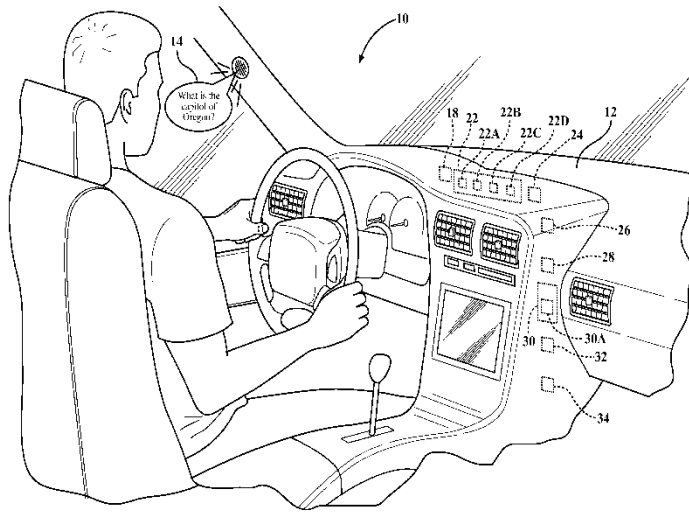

The Patent shows technology that attempts to determine the impairment level of a driver as noted by using eye gaze:

The challenge 14 is configured to determine if the driver is impaired. For example, the challenge 14 may be a verbal response, one challenge 14 selected from the group consisting of a mathematical problem, a repetition of a phrase, a physical act, a horizontal gaze nystagmus test, or a blood alcohol breathalyzer test. The challenge unit 28 may be configured to issue one or more challenges 14. The challenge unit 28 renders the motor vehicle 12 inoperable until the challenge 14 is passed. The challenge unit 28 may be further configured to wait a predetermined period before issuing a challenge 14 in the event the driver fails a challenge 14.<sup>116</sup>

The Patent goes on to state that it attempts to use voice recognition to determine if the driver is slurring speech.

It is unclear if portions of this technology have been incorporated into other technologies. It appears the horizontal gaze test and speech recognition may somewhat obtrusive as it requires a driver to take an additional step. However, other technologies that are being developed or are developed have been able to determine a person's distraction or drowsiness via horizontal gaze without any additional steps by the vehicle operator.

<sup>116</sup> "Impairment evaluation system," Toyota. Patent US10166992B2. Filed May 22, 2015. <https://patents.google.com/patent/US10166992B2/en?q=10166992>

## 117. Toyota Patent: Vehicle occupant information acquisition device and vehicle control system

Toyota Patent filed in 2016 shows camera and other sensors that also include alcohol sensors.

This DMS also intersects with the operation of an Autonomous Vehicle. Sensors in addition for that of alcohol also include sensors for heart rate.

The Patent describes the alcohol sensors in this system:

An acquisition unit is provided in the vehicle in order to acquire various kinds of information about vehicle occupants from the occupants. The information serves as conditions for determining whether or not each occupant is suitable for being the driver. Alcohol sensors 16, cameras 18, a microphone 20, heart rate sensors 22, a display/control panel 24 and a database (DB) 26 serve as the acquisition unit. The database 26 encompasses smartphones, smart watches and the like belonging to individuals.

**Each alcohol sensor 16 is disposed at a position at which the breath of an occupant can be easily detected such as, for example, a headrest or the like.** By detecting alcohol, the alcohol sensor 16 determines whether or not an occupant sitting on a seat is under the influence of alcohol.<sup>117</sup>

The image below is from the Patent.

FIG.1

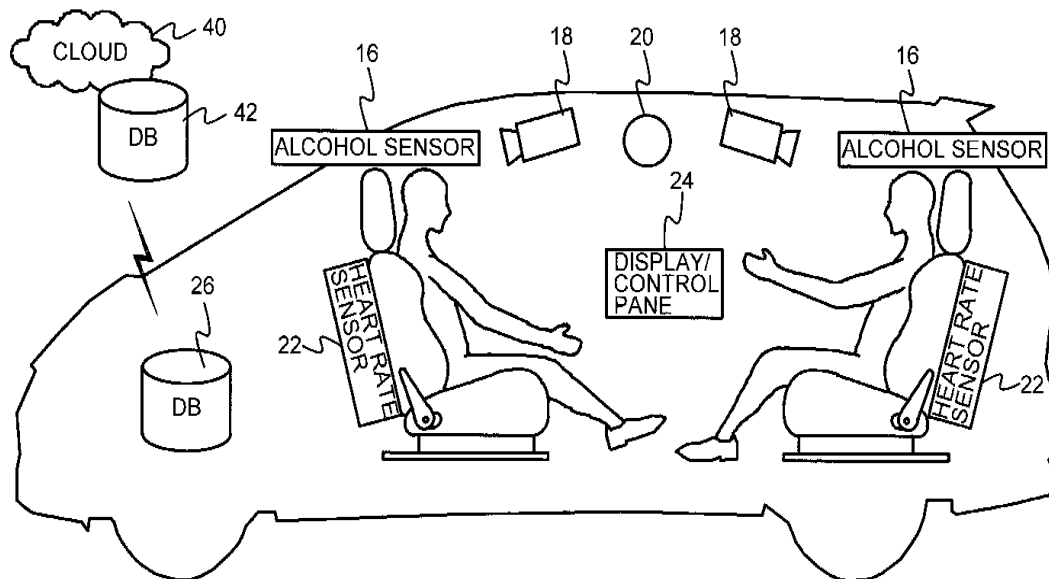

<sup>117</sup> "Vehicle occupant information acquisition device and vehicle control system," Toyota. Patent US9783202B2. Filed June 15, 2016. <https://patents.google.com/patent/US9783202B2/en>

## 118. Toyota Patent: Lane departure warning/assistance method and system having a threshold adjusted based on driver impairment determination using pupil size and driving patterns

Toyota Patent US9542847B2 filed in 2011 is for an eye-based monitoring system that also senses for lane departure. The Patent notes that its pupil detection technology can detect for alcohol use:

Continuing to analyze the driver's pupil may guard against the scenario where the driver consumes a large amount of alcohol shortly prior to operation of the vehicle 100 such that his or her pupils have not yet fully dilated or otherwise changed in size at the moment the vehicle 100 initially processes the size of the pupil. By repeating the collection and analysis processes, the system 200 is able to take into account any further change in the size of the pupil due to the absorption of alcohol or drugs thereby achieving a more accurate assessment of whether the driver is intoxicated.<sup>118</sup>

On the sketch of the Patent to the right, 110 represents where a camera could be to detect a driver's pupil. **This Patent has since expired.** The pupil and camera-based monitoring is in development or deployed by other automakers and suppliers.

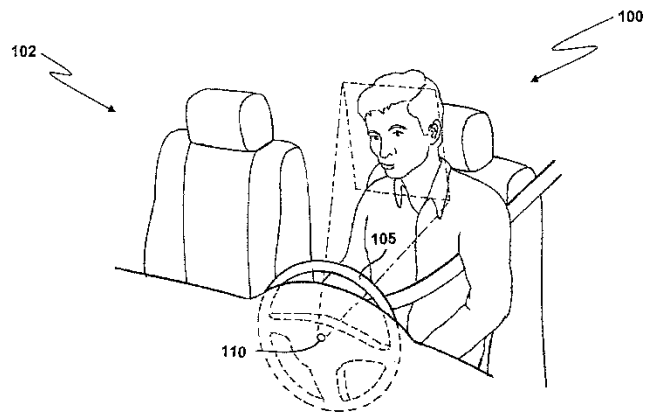

FIG. 1A

<sup>118</sup> "Lane departure warning/assistance method and system having a threshold adjusted based on driver impairment determination using pupil size and driving patterns," Toyota. Patent US9542847B2. Filed August 16, 2013. <https://patents.google.com/patent/US9542847B2/en?q=9542847>

## 119. Toyota Patent: Drunk driving prevention system and external server used for the same

Toyota Patent filed in 2012 is for a breath/air and touch based system for alcohol. The Patent abstract says:

A drunk driving prevention system is equipped with an external server and an on-vehicle component. The on-vehicle component is equipped with a detection unit that detects an alcohol concentration of a driver, an acquisition unit that acquires information on a current position of a vehicle, and a communication unit that transmits to the external server the alcohol concentration as well as the current position information. The external server is equipped with a storage unit that stores a plurality of criteria that relate to an alcohol concentration falling under drunk driving and are different from one another as a result of geographical differences, a communication unit that receives the alcohol concentration and the current position information, and a determination unit that determines, based on that one of the criteria, whether the alcohol concentration received is an alcohol concentration falling under drunk driving.<sup>119</sup>

The image on the right is from the Patent. The 2012 Patent was abandoned in the United States but the Patent original filed in Japan is still active.

FIG. 6

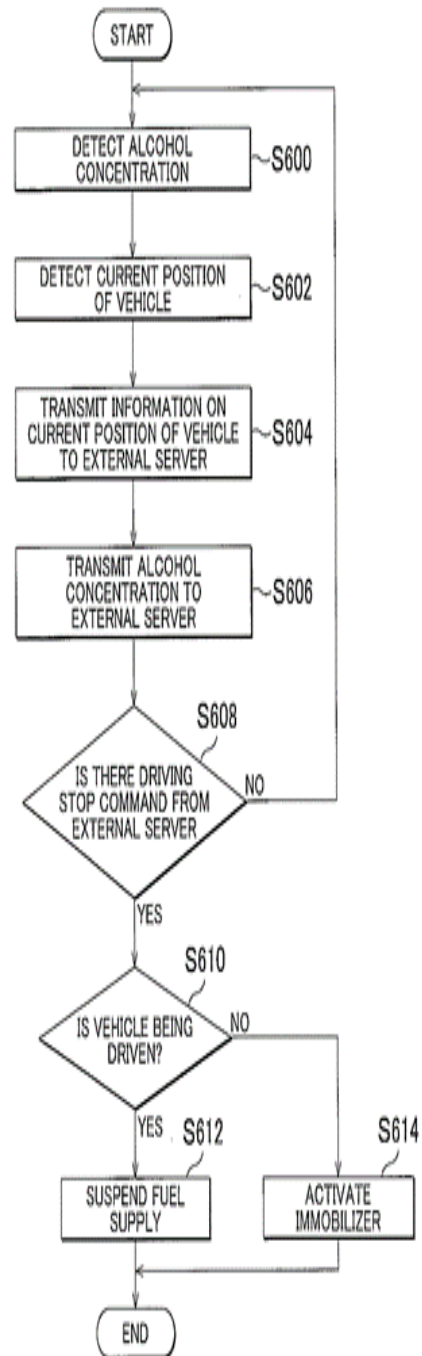

<sup>119</sup> "Drunk driving prevention system and external server used for the same," Toyota. Patent JP2012210931A. Filed March 19, 2012. <https://patents.google.com/patent/JP2012210931A/en?q=20120245763>



## 120. Volkswagen Lane Assist

The system works “If lane markings are detected, this camera-based lane-keeping assistant ensures that the Volkswagen driver stays in lane. If the vehicle veers towards another lane although the direction indicators have not been operated by the driver, the system automatically intervenes by steering back into line. There is also an Adaptive Lane Guidance function (which can be activated and deactivated) that keeps the car within its own lane at all times on an ideal line preferred by the driver.”<sup>120</sup>

### More Information

- Video of technology: <https://www.youtube.com/watch?app=desktop&v=bmRj6rsRj-c>

## 121. Volkswagen Driver Alert System

The technology “identifies failing concentration on the part of the driver and provides the driver with a five-second acoustic warning as well as an optical indication, recommending the driver to take a break, on the instrument cluster. If the driver does not take a break within 15 minutes, the warning is repeated once. At the beginning of each trip, the system analyses factors such as the driver’s characteristic steering behavior. On the road, the Driver Alert System continuously evaluates signals such as the steering angle. In the case of deviations from the steering behavior registered at the beginning of the trip, optical and acoustic alarms are initiated.”<sup>121</sup>

### More Information

- Video of technology: <https://www.youtube.com/watch?v=W12qBrtypb8>

## 122. Volkswagen Patent: Method for estimating the driver's attention of a vehicle

The Patent filed by Volkswagen in 2018 in Germany appears to be part of a larger driver monitoring system as this Patent is for computer software relating to driver attention monitoring.<sup>122</sup> The computer software program that can work with other sensors to determine a driver’s attention.

---

<sup>120</sup> “Lane-Keeping Assistant (Lane Assist),” Volkswagen. <https://www.volkswagen-newsroom.com/en/lane-keeping-assistant-lane-assist-3666>

<sup>121</sup> “Driver Alert System,” Volkswagen. <https://www.volkswagen-newsroom.com/en/driver-alert-system-3932>

<sup>122</sup> “Method for estimating the driver's attention of a vehicle,” Volkswagen. Patent DE102018216511A1. Filed September 26, 2018. <https://patents.google.com/patent/DE102018216511A1/en>

## 123. Volkswagen Patent: Selecting an input mode for a driver information system from a vehicle

The patent filed in 2019 in Germany for this driver monitoring systems says “According to one variant, the selection is made as a function of the driver’s status and the driver’s status is determined using at least one of the following variables:

- a tiredness size; - a pupil size; - an eye movement quantity; - a pitch; - a pulse size”

The patent says:

Driver state determining device determines 24 a current level of awareness and / or drowsiness of the driver. For this purpose, it determines at least some of the parameters explained above using suitable sensor devices (for example a camera device, a microphone device and, for example, the microphone device 18<sup>th</sup> of the driver information system 10 or a biometric sensor). The driver condition determining device 24 then sends a determined driver status to the driver information system 10 out. If this reaches a predetermined critical reference state, the driver information system chooses 10 select the voice input mode as the active input mode from the available input modes.

<sup>123</sup>

The patent seems that it would give the results of the driver’s state immediately. It appears the tech would use a camera, microphone and other sensors to determine a person’s pulse.

This patent is extensive, but it has not been rolled out by Volkswagen. Additionally, the patent was translated from German to English on Google, which may have resulted in some missed translations. However, the driver monitoring tech described in the patent is currently in development but multiple other companies.

The technology could be adapted to determine substance impaired driving or in the Autonomous vehicle space.

---

<sup>123</sup> “Selecting an input mode for a driver information system from a vehicle,” Volkswagen. Patent DE102019206307A1. Filed May 2, 2019. <https://patents.google.com/patent/DE102019206307A1/en>

## 124. Volvo intoxication driver monitoring system

The monitoring system of the driver uses camera and other sensors to determine if the driver is intoxicated, distracted, drowsy or driving erratically. Volvo says the system would also have an intervention “That intervention could involve limiting the car’s speed, alerting the Volvo on Call assistance service and, as a final course of action, actively slowing down and safely parking the car.”<sup>124</sup>

Volvo plans to have the “introduction of the cameras on all Volvo models will start on the next generation of Volvo’s scalable SPA2 vehicle platform in the early 2020s. Details on the exact amount of cameras and their positioning in the interior will follow at a later stage.” The image below is from the Volvo video of the in-car cameras and intervention against intoxication, distraction.



### More Information

- Video: <https://www.media.volvocars.com/global/en-gb/media/videos/250162/in-car-cameras-and-intervention-against-intoxication-distraction-animation1>
- “Volvo to put cameras and sensors in its cars to tackle drunk driving,” CNBC. March 21, 2019. <https://www.cnbc.com/2019/03/21/volvo-to-put-cameras-and-sensors-in-its-cars-to-tackle-drunk-driving.html>
- “Safety first: Volvo to add in-car sensors to prevent drunk driving,” Reuters. March 20, 2019. <https://www.reuters.com/article/volvocars-safety/safety-first-volvo-to-add-in-car-sensors-to-prevent-drunk-driving-idUSL3N2172D8>
- “Volvo Using Technology to Cut Down on Distracted Driving — Due to Technology,” The Detroit Bureau. October 19, 2020. <https://www.thedetroitbureau.com/2020/10/volvo-taking-more-steps-on-car-safety/>

---

<sup>124</sup> “Volvo Cars to deploy in-car cameras and intervention against intoxication, distraction,” Volvo. March 20, 2019. <https://www.media.volvocars.com/global/en-gb/media/pressreleases/250015/volvo-cars-to-deploy-in-car-cameras-and-intervention-against-intoxication-distraction>

## 125. Volvo Patent: Method and system for perceptual suitability test of a driver

The Patent from Volvo was filed originally in 2004 and aims to detect for perpetual errors of drivers or other heavy machine operators.

The technology aims to detect impaired driving and other driving conditions. The Patent says the object of the invention to provide a method and system for automatically:

- Executing a drug recognition expert (DRE) on a driver.
- Testing for the influence of drugs and/or alcohol.
- Conducting perceptual suitability tests on a driver of a vehicle or a person operating equipment or a device while driving a vehicle or operating the equipment or device.
- Executing such suitability tests on the basis of eye and/or head movements or reactions of the related vehicle driver or any other person who operates equipment and/or devices as mentioned above.<sup>125</sup>

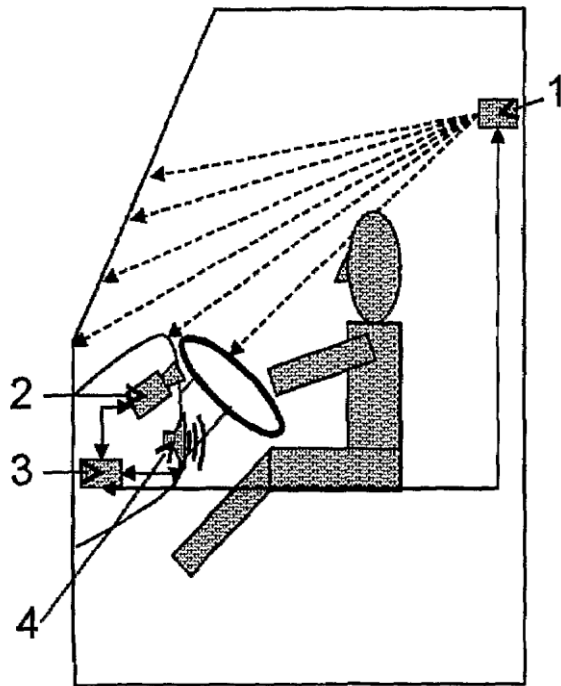

The image above is from the Patent. According to the description of the sketch above, it shows a side view into the cabin of a system comprised of a stimulus generation device 1; an eye movement and/or head movement and/or pupil reaction registration device 2; a computation, control, and output device 3; and a sound generation unit 4.

The Patent was filed in 2004 and in the United States in 2016. It is unclear if portions of this concept are incorporated into other Volvo technologies.

## 126. Volvo Pilot Assist and Lane Keeping Aid

The "Lane Keeping Aid can provide the driver with steering assistance, steering the car back into its lane and/or providing warnings using acoustic signals or steering wheel vibration."<sup>126, 127</sup>

<sup>125</sup> "Method and system for perceptual suitability test of a driver," Volvo. Patent US7455405B2. Filed September 22, 2006. <https://patents.google.com/patent/US7455405B2/en>

<sup>126</sup> "Pilot Assist and Lane Keeping Aid," Volvo. November 24, 2019. <https://www.volvocars.com/en-ca/support/topics/use-your-car/good-to-know/pilot-assist-and-lane-keeping-aid>

<sup>127</sup> "Intellisafe," Volvo. <https://www.volvocars.com/us/about-volvo/human-innovation/future-of-driving/safety>

## 127. Volvo Oncoming Lane Mitigation

The technology “automatically helps you steer back into your lane if it detects that you have crossed the lane markings, heading into the path of an oncoming vehicle. If you don’t take action, this system helps you steer the car back. You’ll get an audible warning signal at the same time the car starts to steer. After the steering intervention has been completed, a message is shown in the Digital Driver Display. At anytime, you can override the automatic steering function.”<sup>128</sup>

### More Information

- Video of technology: <https://www.youtube.com/watch?app=desktop&v=ekAcABtvxJs>

## 128. Volvo Run-off Road Mitigation

The system “can help reduce the risk of a road departure, which could be caused by poor weather conditions. It assists with steering to help put you back on a safer path. The advanced technology operates at higher speeds if you stray over lane markings to the road edge. It intervenes when a road departure scenario is detected to be imminent by your car’s advanced sensor system. The front safety belts are electrically tightened to safeguard you and your front seat passenger.”<sup>129</sup>

### More Information

- Video of technology: <https://www.youtube.com/watch?v=FbrGiQBgpVI>

## 129. Volvo Driver Alert Control

The system “camera detects the side markings painted on the carriageway and compares the section of the road with the driver's steering wheel movements. The driver is alerted if the vehicle does not follow the carriageway evenly.”<sup>130</sup>

### More Information

- Video of technology: <https://www.youtube.com/watch?v=sVDTnFeutOs>

## 130. Volvo Driver Alert System

The system is “intended to assist drivers whose driving ability is deteriorating or who are inadvertently leaving the lane they are driving on.”<sup>131</sup>

---

<sup>128</sup> “Intellisafe,” Volvo.

<sup>129</sup> “Intellisafe,” Volvo.

<sup>130</sup> “Driver Alert Control,” Volvo. <https://www.volvocars.com/en-th/support/manuals/v40/2017w17/driver-support/driver-alert-system/driver-alert-control-dac>

<sup>131</sup> “Driver Alert System,” Volvo. <https://www.volvocars.com/uk/support/manuals/s60/2017w17/driver-support/driver-alert-system/driver-alert-system>

## Tier 1 Auto Suppliers: Driving Performance Monitoring, Driver Monitoring and Passive Alcohol Detection Safety Technologies

There are over 60 systems developed or in development from Tier 1 auto suppliers relating to: driving performance monitoring, driver monitoring, and passive alcohol detection. This section will go through these technologies.

Tier 1	Driver Monitoring Tech (e.g., eyes, head)	Passive Breath or Touch Alcohol Detection Tech	Total
Adient	1		1
Aisin Seiki Co.	1		1
Aptiv	1		1
Autoliv	1	1	2
Bosch	2	1	3
Continental	2	1	3
Delphi/Borgwarner	1		1
Denso	5	3	8
Faurecia	2	1	3
Gentex	2	1	3
Grupo Antolin	1		1
Hitachi	1	1	2
Hyundai Mobis	4		4
Infineon Technologies	1		1
Jabil	1		1
Joyson Safety	1	1	2
Lear	2		2
Leopold Kostal	1		1
LG Electronics Inc		1	1
LG Innotek Co Ltd		1	1
Magna	2		2
Mitsubishi Electric	1		1
Panasonic	1	1	2
Samsung	1		1
Sony	1		1
Sumitomo Riko	1		1
Toyoda Gosei	1		1
Toyota Boshoku	2		2
TS Tech	1		1
Valeo	1	1	2
Visteon Corp	1		1
Yanfeng	1		1
Yazaki	1		1
ZF Friedrichshafen AG	1		1
<b>Total</b>	<b>46</b>	<b>14</b>	<b>60</b>

## 131. Adient seat monitor

Adient is a seat based monitor that can measure heart rates and breathing. According to the website in 2017 “Additionally, integrated health monitoring features can measure breathing and heart rate, providing valuable feedback to enable smart management of passenger health while sitting comfortably on the seat.”<sup>132</sup>

This technology is not widespread in the driver monitoring system space compared to eye and face based monitoring. Seat based systems are under development by automakers and suppliers.

## 132. Aisin Seiki face-based driver monitoring

The system is a face-based driver monitoring system. According to their website “The camera captures the driver’s face and detects the driver’s face orientation and eye open / closed state. It is used in a system to prevent accidents caused by looking aside or falling asleep.”

Aisin Seiki is a Tier 1 auto supplier and it is unclear if this technology is developed already or in development. According to their website, they say “We provide system products that highly control “running,” “turning,” and “stopping” in order to achieve zero traffic accidents. We are also developing products that enhance the enjoyment of driving and comfort such as riding comfort.”<sup>133</sup>

The image below is from Aisin Seiki on the driver monitoring system.

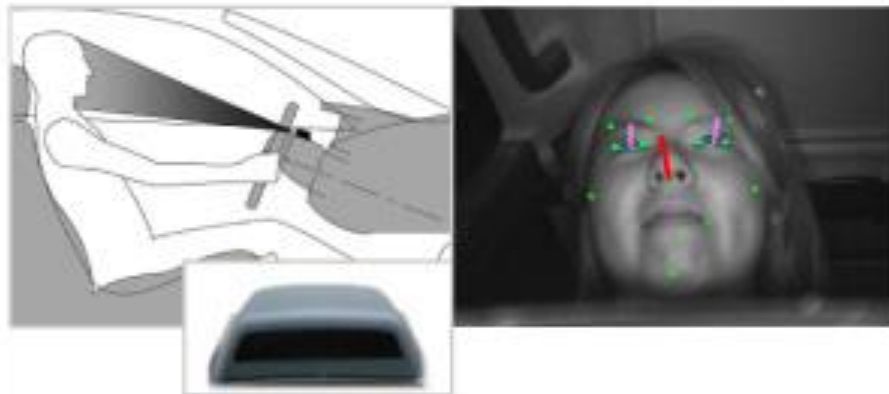

### More Information

- “Aisin Seiki to showcase Human Error Monitoring System at Detroit Auto Show,” Green Car Congress. January 8, 2013. <https://www.greencarcongress.com/2013/01/aisin-20130108.html>

<sup>132</sup> “Adient AI18 demonstrator shows future of automotive seating,” Adient. September 12, 2017. <https://www.adient.com/media/press-releases/2017/09/12/adient-ai18-demonstrator-shows-future-of-automotive-seating>

<sup>133</sup> Aisin Seiki: [https://www.aisin.co.jp/product/automotive/brake\\_chassis/#productTtl](https://www.aisin.co.jp/product/automotive/brake_chassis/#productTtl).

### 133. Aptiv Driver State Sensing

The Aptiv Driver State Sensing system monitor the cognitive state of driver by measuring body positioning, gestures, and eye movement.

The images on the right are of the Aptiv driver monitoring system. The warning for inattentive drive is near the windshield. Green for paying attention and red for inattentive driving.

The system is shown in a video on a vehicle. It is unclear if this system is deployed and widely available for consumer use.



#### More Information

- “Safety and Convenience Innovations Powered by Interior Sensing,” Aptiv. January 21, 2020. <https://www.aptiv.com/insights/article/safety-and-convenience-innovations-powered-by-interior-sensing>.
- Aptiv Video demonstration of the DMS system: <https://vimeo.com/385547091>.
- “Aptiv 2019 Investor Conference presentation” [https://s22.q4cdn.com/336558720/files/doc\\_presentations/2019/07/Aptiv-2019-Investor-Conference.pdf](https://s22.q4cdn.com/336558720/files/doc_presentations/2019/07/Aptiv-2019-Investor-Conference.pdf)



## 134. Autoliv driver monitoring system

Eye and head-based monitoring system that uses a camera. The company website notes their tech:

Autoliv's state-of-the-art driver monitoring system (DMS) can detect distracted and drowsy drivers by accurately measuring eye and head position, driver attention and fatigue. The DMS will invoke action when a dangerous situation is detected or imminent. A reliable analysis of the driver's state will also enable Autoliv to develop technologies that are critical for supporting highly autonomous driving functions, with safe hands-off-wheel operation. Autoliv's DMS understands driver behavior, allowing tomorrow's vehicles to make better decisions to improve comfort and safety.<sup>134</sup>

The image to the right is of Autoliv driver monitoring.

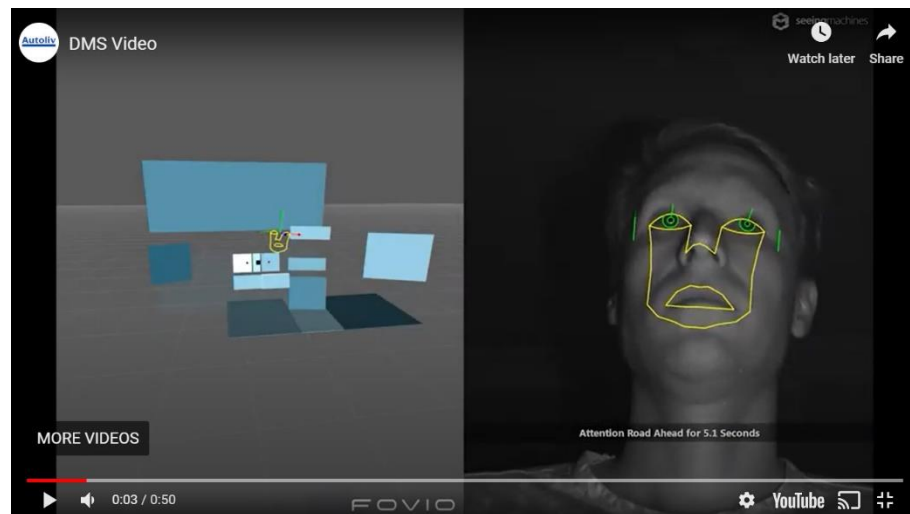

### More Information

- Video of technology: [https://www.youtube.com/watch?v=GB-x01\\_LL3s&feature=youtu.be](https://www.youtube.com/watch?v=GB-x01_LL3s&feature=youtu.be)

## 135. Autoliv alcohol sensor

In a 2012 press release, Autoliv noted of their alcohol sensor “The Autoliv approach uses a non-obtrusive system to measure the alcohol content in the breath of the driver to estimate blood alcohol content (BAC). This is accomplished by applying infrared (IR) spectroscopy as the principle sensing technology. This technology offers the potential for high sensitivity and system reliability at a reasonable cost with low on-going maintenance.”<sup>135</sup>

<sup>134</sup> “Driver Monitoring Systems,” Autoliv. <https://www.autoliv.com/index.php/products/electronics/driver-monitoring-systems>

<sup>135</sup> “Autoliv Alcohol Sensor Enters Next Phase,” Cision. January 11, 2012. <https://news.cision.com/autoliv/r/autoliv-alcohol-sensor-enters-next-phase,c9206160>.

## 136. Bosch camera-based driver monitoring

The system is a camera-based monitor for face movement and other movement of occupants in the vehicle. It can also be used in conjunction with autonomous vehicle driving as according to Bosch it can determine if the “driver is capable of taking back control of the vehicle in a critical situation.”<sup>136</sup>



The image on the right is from the Bosch website on driver monitoring.

The Bosch website says “Based on a driver’s eyelid movements, the interior monitoring system detects if the person is drowsy or distracted by his or her smartphone and triggers an alert if this is the case.”<sup>137</sup>

The system also “The driver monitoring camera monitors the alertness and condition of the driver. It can detect distraction, drowsiness, and microsleeps and can alert the driver in time.”<sup>138</sup>

It is unclear where this technology is currently deployed, but it seems that Bosch is developing this technology in conjunction with Autonomous vehicle technology.

### More Information

- “Bosch develops new Interior Monitoring System,” New Mobility. December 16, 2019. <https://newmobility.global/future-transportation/bosch-develops-new-interior-monitoring-system/>

---

<sup>136</sup> Interior monitoring systems,” Bosch. <https://www.bosch-mobility-solutions.com/en/products-and-services/passenger-cars-and-light-commercial-vehicles/interior-and-body-systems/interior-monitoring-systems/>

<sup>137</sup> “Artificial intelligence in everyday life,” Bosch. <https://www.bosch.com/stories/ces-2020-artificial-intelligence-in-everyday-life/>

<sup>138</sup> “Interior monitoring systems,” Bosch.

## 137. Bosch Patent: Method and device for determining a reaction time of a vehicle driver

The Bosch Patent is for a camera-based system to determine if a person is under the influence of alcohol or fatigued. The Patent is for gauging the reaction time of a driver. The Patent describes the technology:

In order to determine a condition of a driver, for example under the influence of fatigue or alcohol, the reaction time and also the size of the range of vision can be included as important bases for measurement. Reaction time becomes slower when the driver is tired or under the influence of alcohol. In addition, the size of the visual field in which movements are still perceived becomes smaller. This is referred to for example as tunnel vision.

The Patent describes the sketch to the right:

**In FIG. 1, a so-called tunnel vision situation is shown, which is distinguished by a small angle and which permits the inference that driver 2 is under the influence of alcohol or is tired.**

View recognition device 3 is part of a device 9 for determining a reaction time of vehicle driver 2. The described elements of view recognition device 3, namely camera 4, computing device 5, and display device 6, can also be part of device 9 for determining the reaction time. For the recognition of the reaction time, computing device 5 is configured to determine or to measure the time between the displaying of visual stimulus 7 and the recognition of the acquisition of visual stimulus 7 by vehicle driver 2. This time duration corresponds to the reaction time of driver 2.<sup>139</sup>

Fig. 1

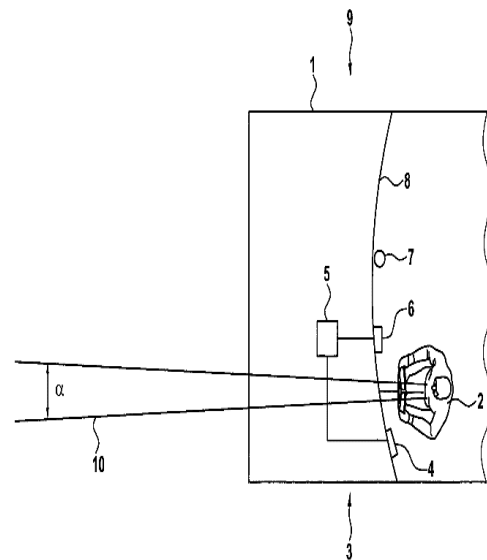

## 138. Bosch Patent: Alcohol immobilizer with emergency drive option

The Bosch Patent filed in 2008 is a touch and sensor based for alcohol impairment.<sup>140</sup> The US Patent is no longer active, but other forms of the Patent are active.

<sup>139</sup> "Method and device for determining a reaction time of a vehicle driver," Bosch. Patent US20160046295A1. Filed August 11, 2015. <https://patents.google.com/patent/US20160046295A1>.

<sup>140</sup> "Alcohol immobilizer with emergency drive option," Bosch. Patent WO2009047074A1. Filed September 11, 2008. <https://patents.google.com/patent/WO2009047074A1/en>

## **139. Continental driver camera with artificial intelligence**

The face-based camera monitoring system that also incorporates Artificial Intelligence. According to Continental, “The Interior Camera can even help with the wellbeing of the driver. Health states and emotions can be recognized and used as input parameters for artificial intelligence solutions like virtual assistants.”<sup>141</sup>

## **140. Continental Patent: Driver Assistance System**

The Continental Patent filed in 2018 describes a driver monitoring system that may include camera system to capture if a driver is attentive or fatigued. It may also include measuring the heart rate of the driver. The patent describes how it would capture if a driver is paying attention in the following:

The degree of attention can be detected, for example, by means of an optical detection system, for example using an interior camera. This can capture the current line of sight. The frequency at which the driver turns his eyes away from the road can be determined from the detection of the current line of sight. The driver’s current level of attention can be determined from this frequency. Further methods according to the prior art for determining the driver’s level of attention can also be used, such as, for example, the detection and evaluation of driver’s biometric parameters, as will be explained in more detail below, the first parameter / the driver’s level of attention being directly or indirectly the driver’s level of fatigue can be derived from the second parameter.<sup>142</sup>

## **141. Continental Patent: Method and device for checking the blood alcohol level of a driver of a vehicle**

The Continental Patent filed in 2010 is for a touch-based sensor to determine alcohol impairment. The Patent says the technology would “equip the driver of an accessory on which is mounted an electronic module comprising a microprocessor, means for measuring the BAC by near infrared spectrometry arranged to extend in contact with the skin of the conductor equipped with the said accessory, and means for transmitting and receiving signals.”<sup>143</sup>

---

<sup>141</sup> “More than meets the eye,” Continental. <https://www.continental-automotive.com/en-gl/Passenger-Cars/Information-Management/ICAM-Campaign>

<sup>142</sup> “Driver assistance system, vehicle, method for operating the driver assistance system, computer program and computer-readable storage medium,” Continental. Patent DE102018210367A1. Filed June 26, 2018. <https://patents.google.com/patent/DE102018210367A1/en>

<sup>143</sup> “Method and device for checking the blood alcohol level of a driver of a vehicle,” Continental. Patent WO2011038803A1. Filed August 13, 2010. <https://patents.google.com/patent/WO2011038803A1/en>

## 142. Delphi/Borgwarner eye driver monitoring system

The system tracks eye movement for distraction. According to the description of the 2016 YouTube video by Delphi the system “an enabler for automated driving, intelligently monitors the driver’s fatigue and distraction level and then reacts. The driver can be warned via seat and steering wheel vibrations or the system can offset driver workload or take specific action to help ensure safety.”

### More Information

- Video of technology: <https://www.youtube.com/watch?v=p2z8AFFSITk>.

## 143. Denso Driver Status Monitor

The face-based monitoring DENSO’s Driver Status Monitor “uses a camera to capture an image of the driver’s face and establishes the driver’s condition based on visual analysis. It detects carelessness, distraction and drowsiness, and then alerts the driver of any potential danger.”<sup>144</sup>

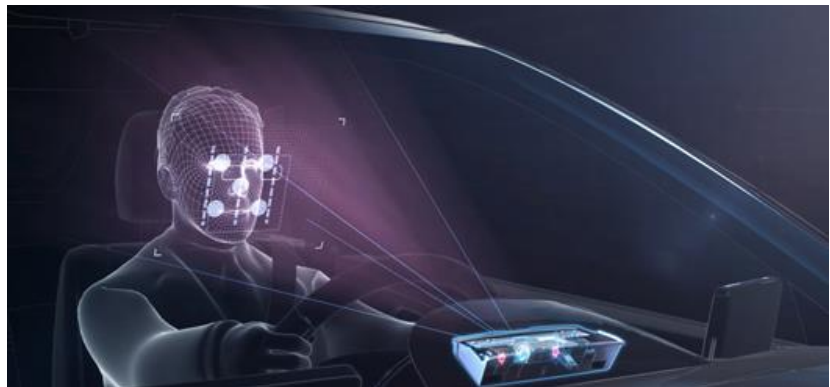

The image to the right is a Denso concept of the technology.

The technology has been around since at least 2013 as it was featured on Denso’s YouTube channel. Denso says of the technology “is a highly adaptable feature that can be used in multiple capacities to make our roads safer.”<sup>145</sup>

### More information

- Video of technology from 2013: [https://www.youtube.com/watch?v=vanHz\\_lfEU](https://www.youtube.com/watch?v=vanHz_lfEU)

---

<sup>144</sup> “Driver Status Monitor,” Denso. <https://www.denso.com/global/en/business/products-and-services/mobility/pick-up/dsm/>.

<sup>145</sup> “Denso’s driver status monitor,” Denso in North America. YouTube. January 28, 2013. [https://www.youtube.com/watch?v=\\_vanHz\\_lfEU](https://www.youtube.com/watch?v=_vanHz_lfEU)

## 144. Denso Patent: Dozing alert apparatus

The Denso Patent filed originally in 2020 is for a face and eye based monitoring system to determine drowsy driving. The system works by if “a drowsiness level of a driver in a vehicle is determined. A preliminary alert is performed in response to that the drowsiness level is higher than an alert threshold value. A main alert is performed to prompt the driver to wake up from drowsiness as necessary after the preliminary alert. In response to that a predetermined response operation by the driver is detected within a predetermined time after the preliminary alert, the alert threshold value is changed to be higher.”<sup>146</sup>

## 145. Denso Patent: Vehicular user hospitality system

The Patent filed by Denso in 2008 is for a: face, steering wheel, body sensor and voice-based monitoring system technology. The image on the right is from the Patent.<sup>147</sup>

FIG. 10

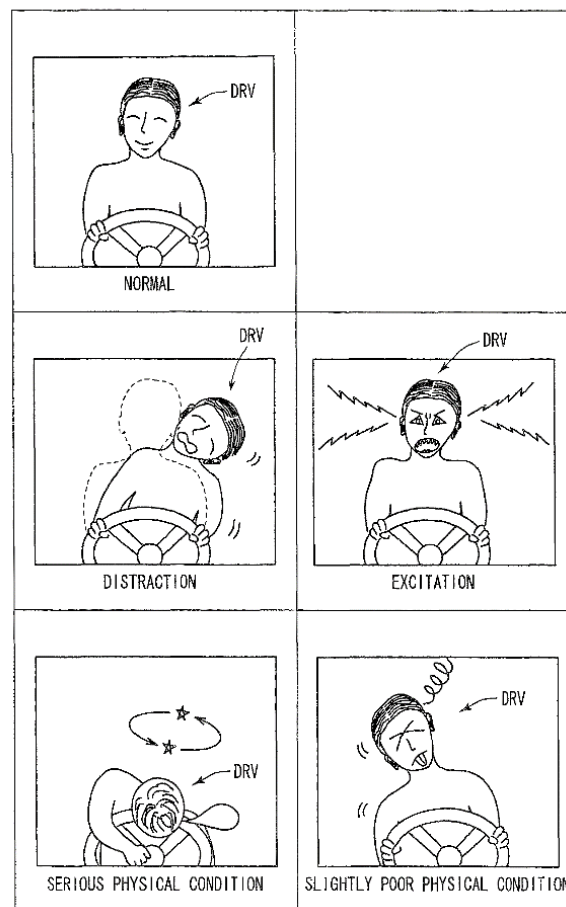

<sup>146</sup> “Dozing alert apparatus,” Denso. Patent US20200286358A1. Filed May 26, 2020.  
<https://patents.google.com/patent/US20200286358A1>

<sup>147</sup> “Vehicular user hospitality system,” Denso. Patent US7821382B2. Filed July 15, 2008.  
<https://patents.google.com/patent/US7821382B2>

## 146. Denso Patent: Driving assist device

This Denso Patent filed in 2015 is for technology that monitors the driver using camera and other sensors in the vehicle. The images below from the Patent show how the system can measure the condition of the driver.<sup>148</sup>

FIG. 1A

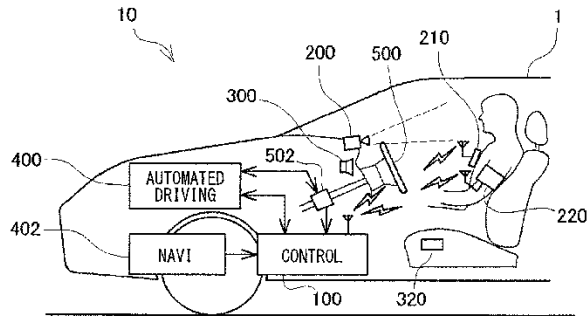

FIG. 2

BASIC MEASUREMENT VALUES

DETECTION ITEM	DETECTION CONTENT
FACE DIRECTION	LOOKING-ASIDE TIME AND STATIONARY TIME
BLINKING FREQUENCY	NUMBER OF BLINKS PER MINUTE
EYE OPEN DEGREE	RATIO OF EYE OPEN TIME IN A MINUTE
HEART RATE	NUMBER OF HEART BEATS PER MINUTE
BLOOD PRESSURE	MAXIMUM AND MINIMUM BLOOD PRESSURES

FIG. 1B

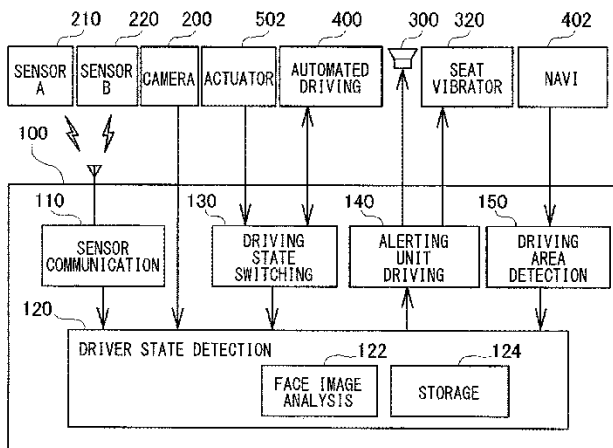
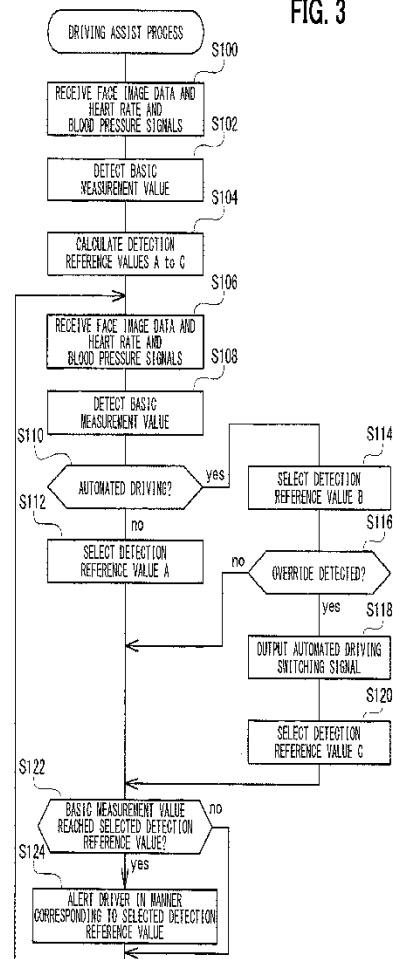

FIG. 3



<sup>148</sup> "Driving assist device," Denso. Patent US9855956B2. Filed February 2, 2015. <https://patents.google.com/patent/US9855956B2>

## 147. Denso Patent: Onboard system, vehicle control device, and program product for vehicle control device

The Denso Patent filed in 2015 looks at sensors including face images and also for brainwaves and relates to when to transfer control of a vehicle between a driver and in self-driving autonomous vehicle mode. Below is an image from the Patent.<sup>149</sup>

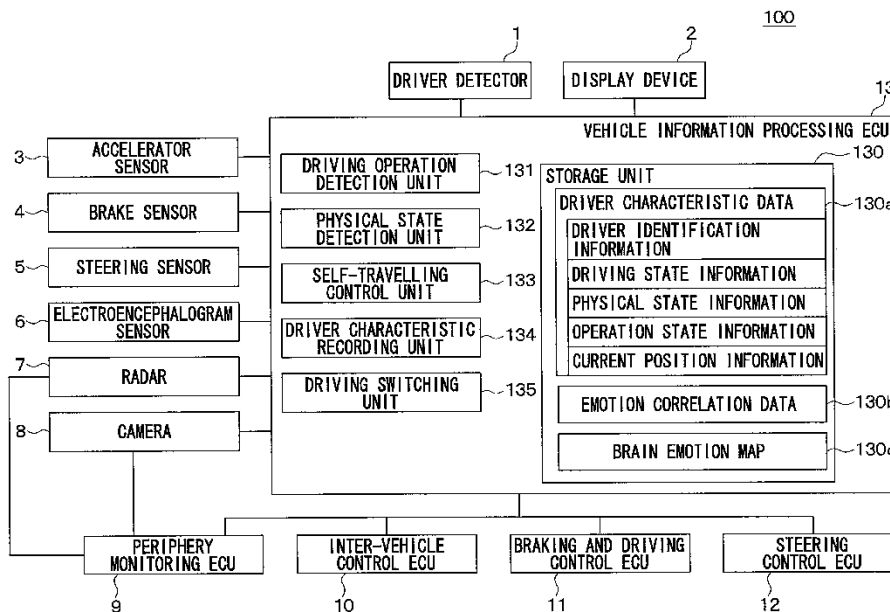

<sup>149</sup> "Onboard system, vehicle control device, and program product for vehicle control device," Denso. Patent US10398368B2. Filed September 8, 2015. <https://patents.google.com/patent/US10398368B2>



## 148. Denso, Soken Patent: Engine starting controller

The Denso Patent filed in 2009 uses a camera and other direct sensors to determine alcohol-impairment. The camera detection aspect seems intended to verify the identity of the user of the vehicle. However, the alcohol sensor technology is described as:

The alcohol concentration determiner calculates an index value of a blood alcohol concentration of the driver based on the pulse detected at the detection part by the sensor, and determines whether the index value exceeds a critical value of a drinking assessment or not. The permission means permits the driver to start an engine of the vehicle when it is determined by the individual certification means that the driver of the vehicle is the authorized person and it is determined by the alcohol concentration determiner that the index value does not exceed the critical value of the drinking assessment. The sensor is configured to detect the pulse of the driver at the detection part and to take the image of the detection part when the driver brings the detection part close to the case.<sup>150</sup>

FIG. 3

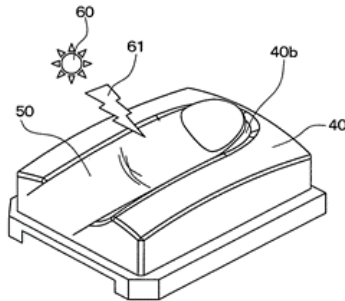
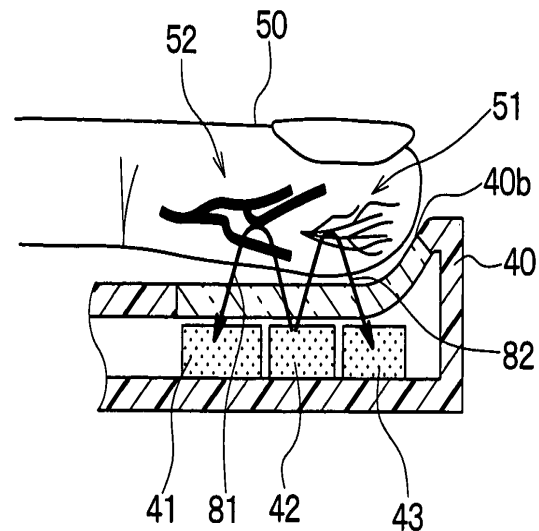
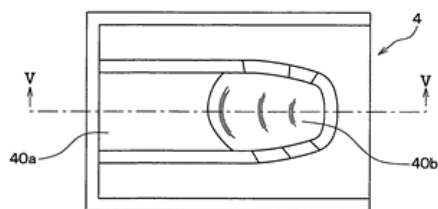

FIG. 4



The sketches above from the Patent show a touch based system to determine alcohol impairment.

<sup>150</sup> "Engine starting controller," Denso, Soken. Patent US8469134B2. Filed July 30, 2009. <https://patents.google.com/patent/US8469134B2/en?q=8469134>

## Denso, Soken Patent Engine starting controller (continued)

The sketch to the right of the Patent shows how the system would operate or not operate depending if the user is alcohol impaired. <sup>151</sup>

FIG. 7

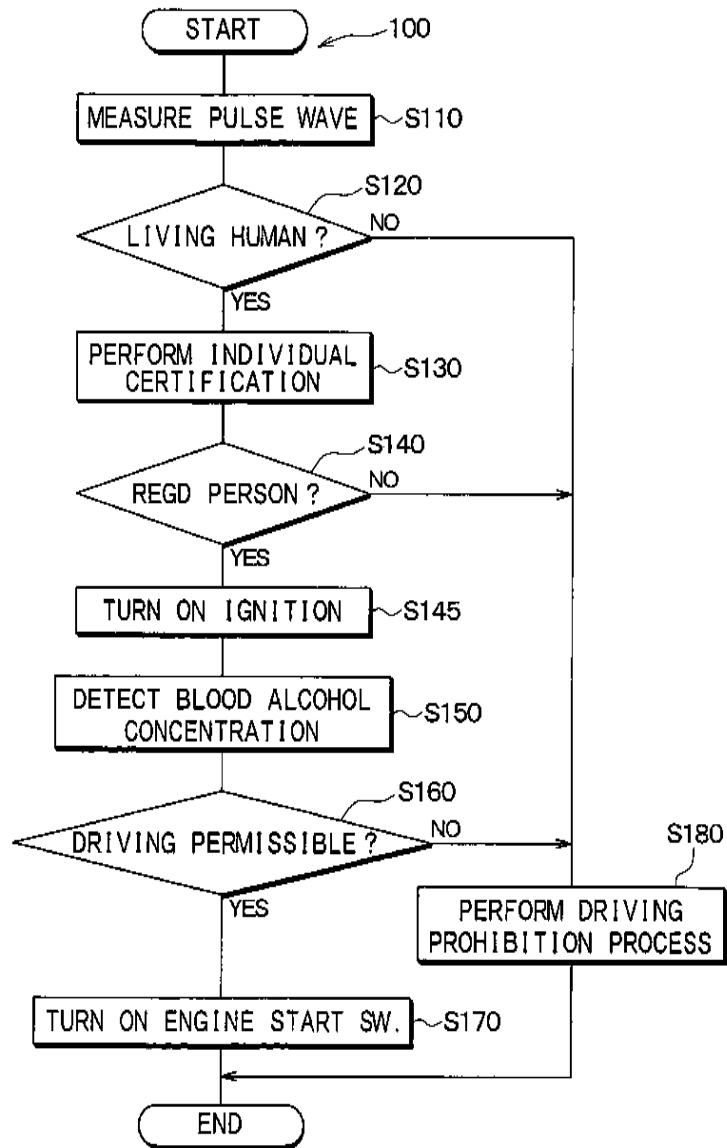

<sup>151</sup> "Engine starting controller," Denso, Soken. Patent US8469134B2.

## 149. Denso Patent: Alcohol detection system and method for vehicle

The Denso Patent filed in 2009 is for technology that includes breath and air-based alcohol sensors. The Patent states:

An alcohol detection system detects alcohol concentration in breath air of a driver seating in a vehicle, permits normal travel of the vehicle when alcohol concentration measured under the predetermined stable operation state is below a threshold level, and prohibits travel of the vehicle over a predetermined travel speed when the alcohol concentration is over the threshold level. The alcohol detection system detects a pre-driving output signal outputted necessarily before an engine switch is manipulated, and instruct start of an alcohol measurement preparation operation when the pre-driving output signal is detected. Thus, measurement of alcohol concentration can be started without necessitating long wait time.<sup>152</sup>

The following image is from the Patent. The image shows a flowchart of the alcohol concentration measurement processing.

FIG. 6

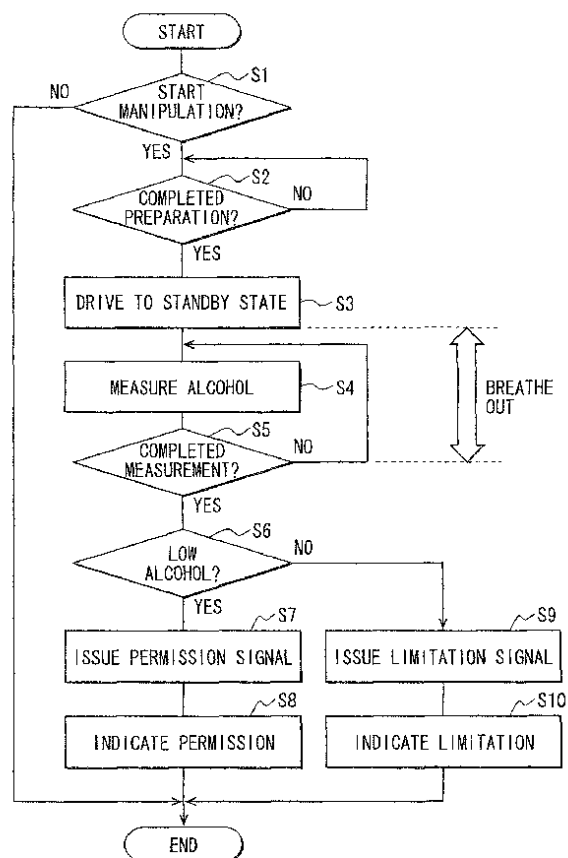

<sup>152</sup> "Alcohol detection system and method for vehicle," Denso. Patent US8201437B2. Filed August 10, 2009. <https://patents.google.com/patent/US8201437B2/en?q=8201437>

## 150. Denso Patent: Alcohol concentration detecting device

The Denso Patent filed in 2010 is for a passive breath based alcohol sensors. The Patent states the technology is:

An alcohol concentration detecting device for a vehicle includes an alcohol sensor to detect alcohol component contained in an expiration of an occupant of the vehicle, a gas sensor to detect gas components other than the alcohol component contained in the expiration, and an alcohol-detecting controller to calculate alcohol concentration based on detection value of the alcohol sensor. The alcohol-detecting controller corrects the calculated alcohol concentration based on detection value of the gas sensor. The alcohol sensor and the gas sensor are configured to further detect a state of air in a passenger compartment of the vehicle.<sup>153</sup>

The following images are from the Patent. FIG. 2 shows an alcohol sensor of the alcohol concentration detecting device. FIG. 6 is a flow chart illustrating an alcohol concentration calculation program executed by the ECU.

FIG. 2

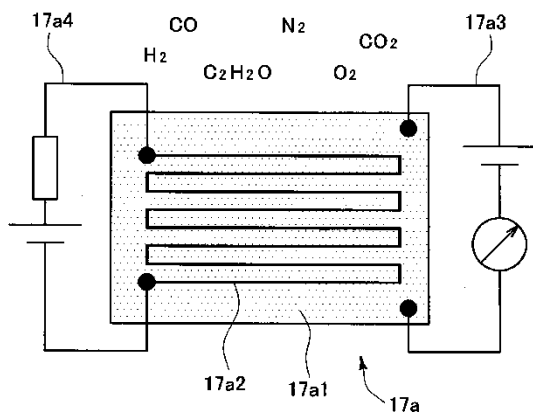
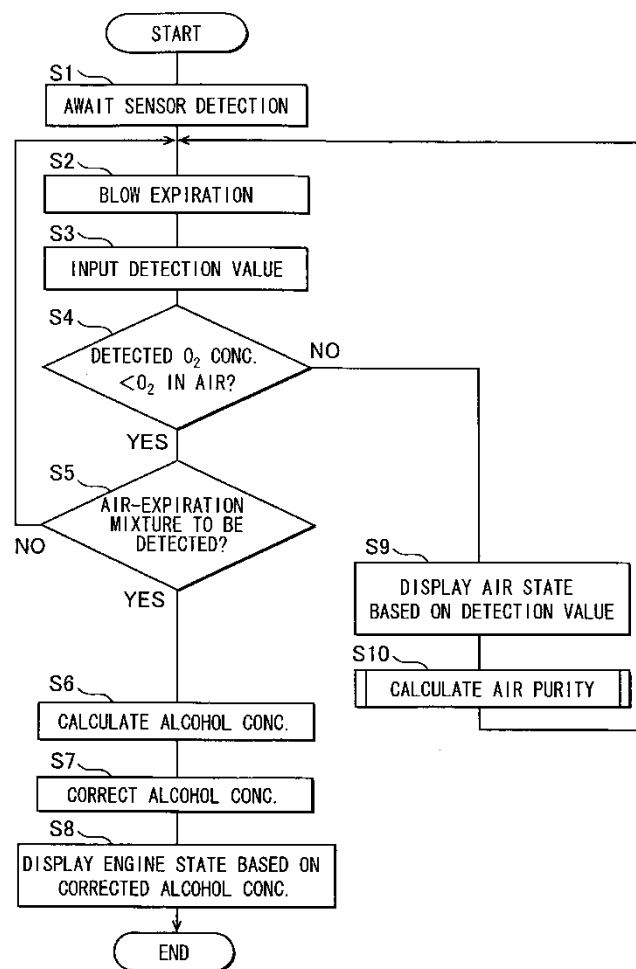

FIG. 6



<sup>153</sup> "Alcohol concentration detecting device," Denso. Patent US8441357B2. Filed November 1, 2010. <https://patents.google.com/patent/US8441357B2/en?q=8441357>

## 151. Faurecia Automotive Seating: Vehicle seat with integrated sensors

The Patent filed in 2015 is for seat sensors that can help in determining a driver or occupant's state. The Patent describes how the technology could work with other car systems to substance impairment:

A driver-capability assessment mode may use sensor data collected by electronics system 16 to determine if the driver's capability to operate the vehicle is impaired due to overload, fatigue, drowsiness, stress, and alcohol or drug impairment. As a result, computer 54 may command via output 56 various equipment in the vehicle to communicate to the driver that their capability is impaired. Computer 54 may also take command of the vehicle to slow the vehicles speed or call for assistance.<sup>154</sup>

The Sketches of the Patent shows how the sensors (16) in the seat may help detect possible impairment by the driver.

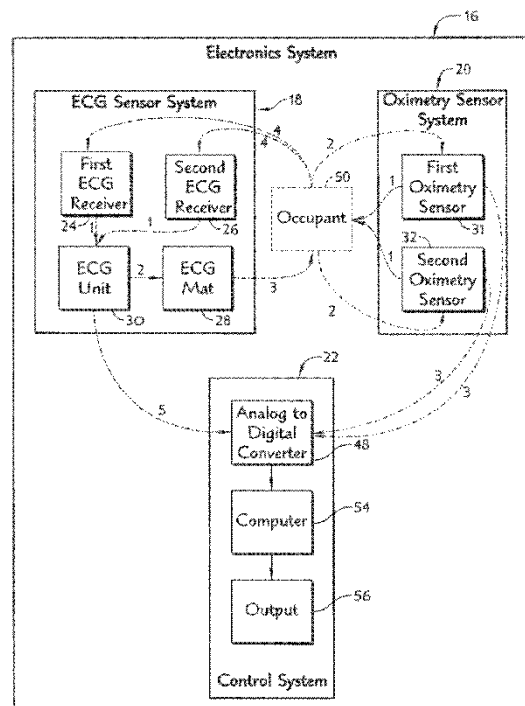
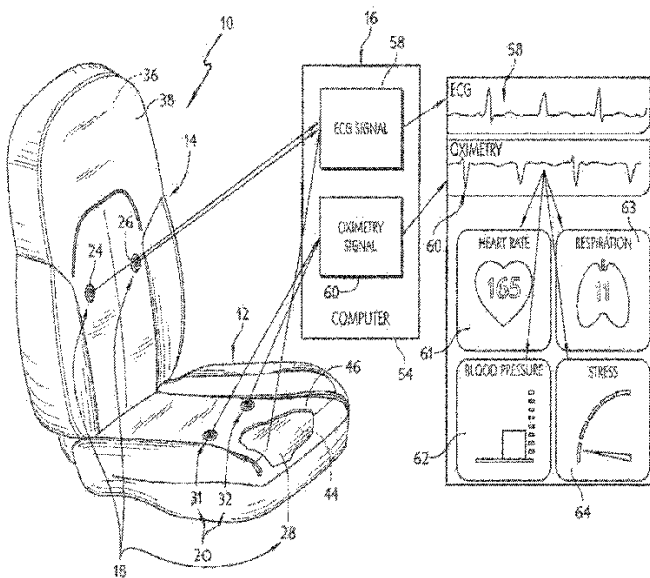

FIG. 8

<sup>154</sup> "Vehicle seat with integrated sensors," Faurecia Automotive Seating. Patent US9848814B2. Filed February 20, 2015. <https://patents.google.com/patent/US9848814B2>.

## 152. Faurecia Clarion driver monitoring

The software and hardware components for Driver Monitoring Systems. Faurecia Clarion says:

Our solutions are built on a scalable architecture that can integrate a range of different onboard cameras (near infrared, thermal), radars or biometric sensors that address multiple use cases. This allows automakers to maximize their technology investment through solutions that meet evolving safety requirements as well as providing data to enhance users' onboard comfort.”

We support automakers from full camera and sensor systems to standalone software managing multiple situations: multi-person detection, driver identification, distraction and drowsiness monitoring, gesture analysis, emotional assessment and health monitoring.<sup>155</sup>

The company notes they “support automakers” with their technology which seems to paint a picture that their technology is currently being deployed. The image on the right is of the driver monitoring system from Faurecia Clarion.

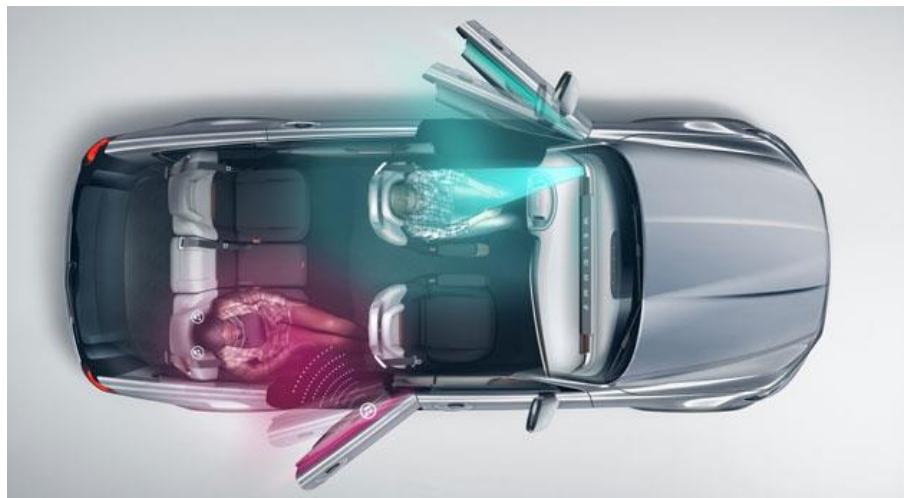

## 153. Faurecia alcohol air sensors

In addition to working on biometric sensors to monitor heart rates, breathing rates, heart rates, and blood pressure, Faurecia is working on gas sensor technology for inside vehicles. Specifically, Faurecia has “Gas sensors are another key area of interest for improving in-car air quality. Teams have extensively researched the right combination of sensors and algorithms that can evaluate the composition of gases and odours in the cabin, including alcohol levels.”<sup>156</sup>

---

<sup>155</sup> “Occupant Monitoring Systems for safety and wellbeing,” Faurecia Clarion. <https://www.faurecia-clarion.com/technology/immersive-experiences>.

<sup>156</sup> “From safety to comfort: we want to do more with technology,” Faurecia. July 25, 2019. <https://www.faurecia.com/en/newsroom/safety-comfort-we-want-do-more-technology>

## 154. Gentex biometrics system

The system monitors a driver's eye for security reasons. As this technology monitors the iris, it could have other driver monitoring functions. It is unclear if this biometric system only monitors once a driver enters a vehicle and immediately stops or if it is constant monitoring of the driver.

Gentex says "The driver's eyes are key to securing and customizing the in-vehicle, connected-car experience," said Downing. "By knowing exactly who is behind the wheel, automakers can implement vehicle security, personalize the vehicle cabin, and secure access to cloud-based accounts, apps, and additional connected-car services."<sup>157</sup>

The rearview mirror system touts itself as "Enter Biometrics: where near-infrared emitters, iris-scanning cameras, and system-level intelligence opens a world of opportunity for automakers. With leading biometric partners by our side, Gentex is changing the game in vehicle security, comfort and personalization."<sup>158</sup>

### More Information

- Video of technology: <https://youtu.be/43OgOZYeF6c>

## 155. Gentex driver monitoring system

The system is a "mirror-integrated, camera-based driver monitoring system (DMS) can monitor alertness, gaze location, behavior, and driver readiness for autopilot return of control."<sup>159</sup>

The image on the right is from the video of the technology from Genetex.

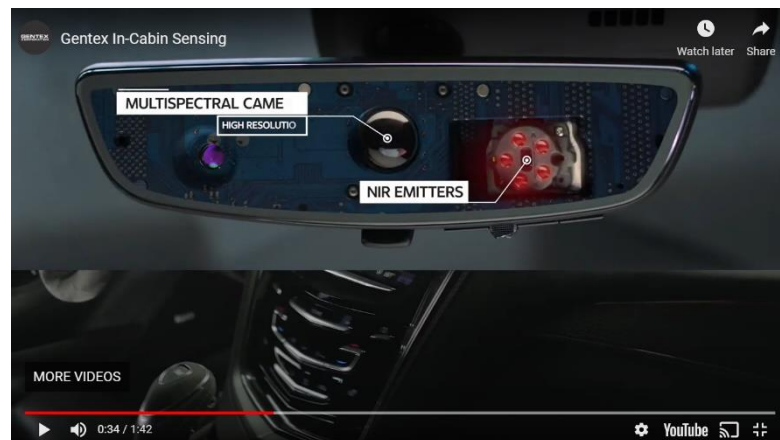

### More Information

- Video of technology: <https://youtu.be/zsBT0kfMKHs>

<sup>157</sup> "Gentex to Demonstrate New Connected Car, Biometrics and Digital Rear Vision Technologies at CES 2018," Gentex. January 2, 2018. <https://ir.gentex.com/news-releases/news-release-details/gentex-demonstrate-new-connected-car-biometrics-and-digital-rear>

<sup>158</sup> "Connected on every level," Genetex

<sup>159</sup> "Connected on every level," Genetex. <https://www.gentextech.com/connectivity-sensing.html>.

## 156. Genetex in-cabin sensing

The system can detect alcohol. The description of the technology is “Keep autonomous and ride-share vehicles operational and passengers safe with in-cabin sensing units that use a variety of sensing methods to detect smoke, vape, VOCs, alcohol, and airborne contaminants.”<sup>160</sup>

### More Information

- Video of technology: <https://youtu.be/lLeg-fP16X8>

## 157. Grupo Antolin driver monitoring

### Methods and systems

Grupo Antolin is a partner with Cippa (formal EyeSight) in cabin integration of driver monitoring. Their website says:

Grupo Antolin’s technological knowhow, the ability to integrate 3<sup>rd</sup> party solutions into its components and development of their control electronics, will be paired with Eyesight Technologies’ advanced in-cabin sensing solutions to deliver smart-integrated systems with great added value. The collaboration will provide car manufacturers with in-cabin solutions tailored to the needs of future electric, connected, and semi-autonomous to fully autonomous vehicles, leveraging the technological capabilities of driver and occupancy/interior monitoring.<sup>161</sup>

This is part of Cippa and integrates with the camera system. Grupo Antolin is one of multiple partners with Cippa in integrating driver monitoring technology.

## 158. Hitachi driver monitoring system

The 2017 presentation from Hitachi shows a system that monitors the: face, eyes, breathing and heart.<sup>162</sup>

## 159. Hitachi Patent: Ion detecting device

The Hitachi Patent filed in 2012 is for an air and breath-based sensor that can detect alcohol.<sup>163</sup>

---

<sup>160</sup> “Connected on every level,” Genetex

<sup>161</sup> “Grupo Antolin and Eyesight Technologies team up to provide intelligent in-cabin monitoring solutions,” Grupo Antolin. January 2, 2020. <https://www.grupoantolin.com/en/grupo-antolin-and-eyesight-technologies-team-provide-intelligent-cabin-monitoring-solutions>

<sup>162</sup> “Driving with AI: The Future of Mobility and Transportation,” Hitachi. 2017. <https://www.hitachivantara.com/en-us/pdf/presentation/future-of-mobility-and-transportation.pdf>

<sup>163</sup> “Ion detecting device,” Hitachi. Patent US8921776B2. Filed March 26, 2012. <https://patents.google.com/patent/US8921776B2>



## 160. Hyundai Mobis Patent: Apparatus and method for detecting driver status

The Hyundai Mobis Patent filed in in 2015 is for driver state monitoring. The patent summary states “method for detecting a driver status, which grasp a driver’s mental and physical condition to determine whether or not a driver drives a vehicle with safety and induce the driver to drive the vehicle with safety in various ways when the driver is determined not to be in a safe driving state so as to protect the driver.”

The patent says “The driver status information acquisition portion may include one or more of a microphone, a driver observation camera, an ECG (electrocardiogram) sensor, an EEG (electroencephalogram) sensor, and a PPG (photoplethysmography) sensor, in order to acquire information according to a driver status during driving of a vehicle.

Each of the EEG sensor, the ECG sensor, and the PPG sensor may be a wearable sensor.”<sup>164</sup>

The driver monitoring system below does not appear to be something that would be worn, but any technology that is wearable is not-workable. Below is an image from the patent.

FIG.2

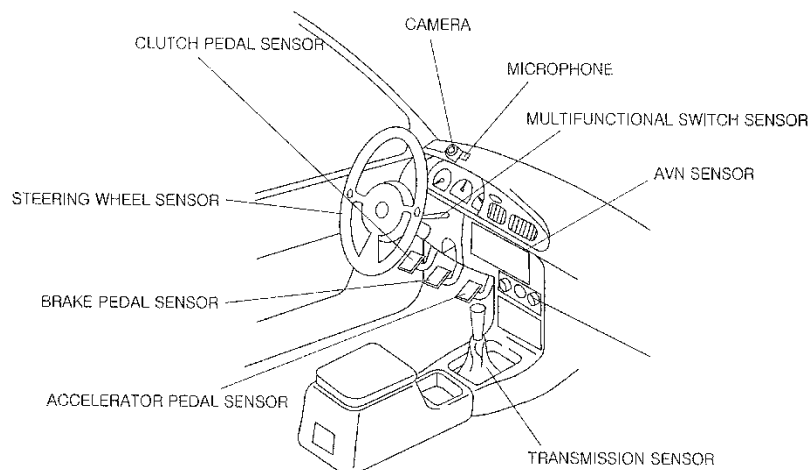

<sup>164</sup> “Apparatus and method for detecting driver status,” Hyundai Mobis. Patent US9682711B2. Filed January 16, 2015. <https://patents.google.com/patent/US9682711B2>

## 161. Hyundai Mobis Patent: Apparatus and method of safety support for vehicle

This Patent filed in 2019 is for driver state monitoring, vehicle control, and autonomous vehicle technology. It monitors movement of the body, including the face and eyes. If a person is determined unable to operate the vehicle, the tech appears to allow for the vehicle to take over and include autonomous vehicle technology. The patent states:

The driver monitoring unit 110 may monitor the physical features, physical characteristics, posture and control intention of a driver. The driver monitoring unit 110 may include various sensors and devices for performing the above-described function. For example, the driver monitoring unit 110 may include a camera or radar for monitoring the physical features, physical characteristics and posture of the driver, and a steering wheel angle sensor, acceleration pedal sensor and brake pedal sensor for monitoring the vehicle control intention of the driver.<sup>165</sup>

The image on the right is from the Patent.

The Patent is very exhaustive and expansive. It is unclear if this technology has been incorporated into the Hyundai Mobis technology called “DDREM(Departed Driver Rescue and Exit Maneuver)” system. Additionally, as this technology involved Autonomous Vehicle technology, AV technology has received billions of dollars of investment and is the process of being tested.

### More Information

- Patent filed in 2017 in the United States: US20200098265A1. <https://patents.google.com/patent/US20200098265A1>.

<sup>165</sup> “Apparatus and method of safety support for vehicle,” Hyundai Mobis. Patent US20200098265A1. Filed November 27, 2019. <https://patents.google.com/patent/US20200098265A1>

FIG. 16

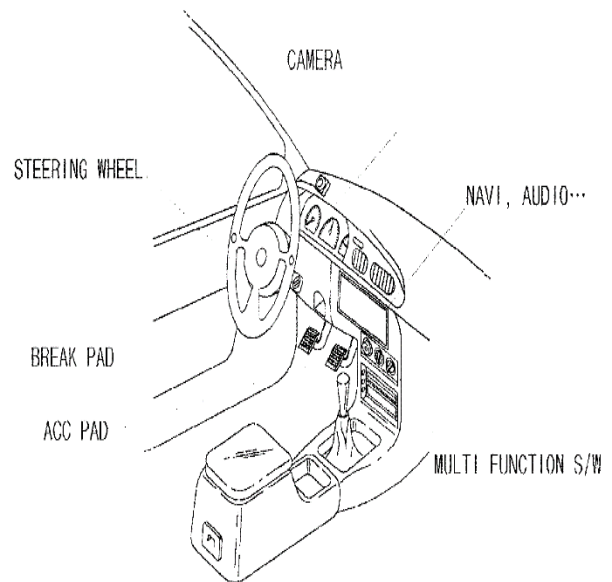

(a)

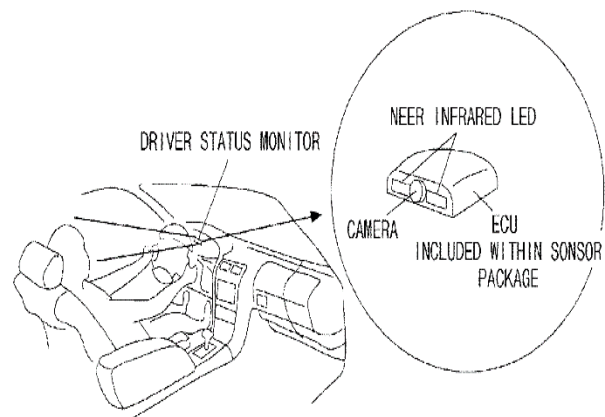

(b)

## 162. Hyundai Mobis Patent: Autonomous driving apparatus and method

The Patent filed in 2020 is for autonomous driving and for driver monitoring. Specifically, the system is described in the following way:

Furthermore, if a behavior of the passenger is not detected through the sensor unit 500 or the bio signal of the passenger detected by the sensor unit 500 has a pattern different from that of a normal bio signal previously stored in the memory 620 as a bio signal in the normal physical condition of the passenger, the processor 610 may transmit a rescue signal to an external organization.

[0092]

That is, if a behavior of the passenger is not detected by the internal camera sensor 535 provided within the sensor unit 500 (i.e., the passenger does not move) or a bio signal (e.g., a pulse beat or a body temperature) of the passenger detected by a bio sensor provided within the sensor unit 500 has a pattern different from that of the normal bio signal, the processor 610 may determine that an emergency situation has occurred in the passenger, and may transmit a rescue signal to an external organization (e.g., a nearby hospital, a fire station or a police station) necessary for the passenger.<sup>166</sup>

FIG. 4

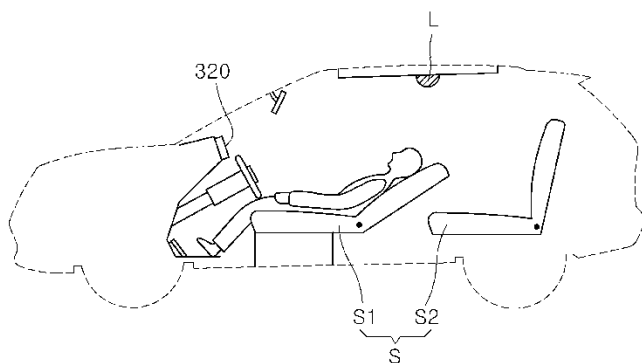
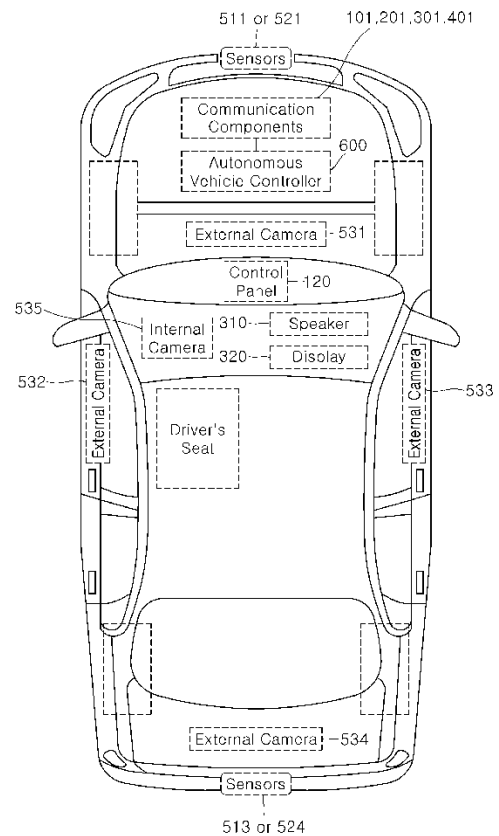

FIG. 3



The images above and to the left are from the Patent. FIG. 3 shows the system comes with an internal camera. FIG 4. Appears to show the vehicle in autonomous driving mode.

<sup>166</sup> "Autonomous driving apparatus and method," Hyundai Mobis. Patent US20200369297A1. Filed May 19, 2020. <https://patents.google.com/patent/US20200369297A1>

## 163. Hyundai Mobis Patent: Autonomous driving apparatus and method

This Patent filed in 2020 monitors a driver and their condition and if the driver can safely operate a vehicle when it is not in autonomous vehicle mode. The system uses a camera as noted in the Patent:

" An internal camera sensor 535 for photographing the inside of a vehicle may be mounted at a given location (e.g., rear view mirror) within the vehicle. The processor 610 of the autonomous driving integrated controller 600 may monitor a behavior and state of a passenger based on an image captured by the internal camera sensor 535, and may output guidance or a warning to the passenger through the output unit 300memory."

The passenger state determination module 616 may determine a state and behavior of a passenger based on a state and bio signal of the passenger detected by the internal camera sensor 535 and the bio sensor. The state of the passenger determined by the passenger state determination module 616 may be used for autonomous driving control over an ego vehicle that autonomously travels or in a process of outputting a warning to the passenger.<sup>167</sup>

## 164. Infineon Technologies

A "3D" camera-based monitoring system of the driver that interacts with advanced driver assistant systems and autonomous vehicle technology.

The technology is described as "Today's advanced driver assistant systems (ADAS) and, perhaps in the future, autonomous cars require precise information about the driver's focal point and what's happening inside the vehicle. This is where 3D camera-based, in-cabin sensing applications come in. They recognize driver behavior and deliver this information to the ADAS system so it can react accordingly."<sup>168</sup>

### More Information

- Infineon In-Cabin Sensing:  
<https://www.infineon.com/cms/en/applications/automotive/chassis-safety-and-adas/in-cabin-sensing/>

---

<sup>167</sup> "Autonomous driving apparatus and method," Hyundai Mobis. Patent US20200369293A1. Filed May 12, 2020. <https://patents.google.com/patent/US20200369293A1>

<sup>168</sup> "Infineon - In-cabin sensing applications based on Infineon REAL3™ 3D image sensor family," Avnet Asia Connect. [https://docs.avnet.com/asia/marcomm/eDMs/AAC201712/Infineon\\_tc.html](https://docs.avnet.com/asia/marcomm/eDMs/AAC201712/Infineon_tc.html)

## 165. Jabil driver monitoring

Camera platform to support driver monitoring system software, partner with Cippa. The company website says:

Camera-based Driver Monitoring Systems (DMS) are an integral element of next-generation ADAS solutions. DMS are increasingly being used by the automotive & transportation industries to reduce distraction and drowsiness related crashes. And they must be present in all vehicles capable of SAE levels 3-4 autonomous driving – to ensure the driver is awake and alert and capable of taking back control of the vehicle after “hands-off and feet off” modes.”

Jabil offers a Camera Platform optimized to support Driver Monitoring System software. Jabil’s expertise in optics industrialization and manufacturing has delivered a highly accurate and dependable DMS camera. The Camera Platform is application ready and can be tailored to customers’ requirements. Evaluation hardware systems are available now for lab and vehicle test and development.<sup>169</sup>

Below are images from Jabil.

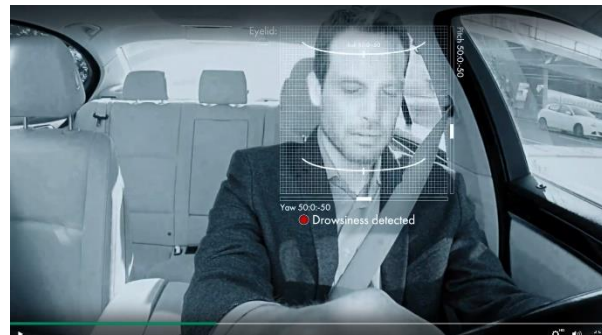
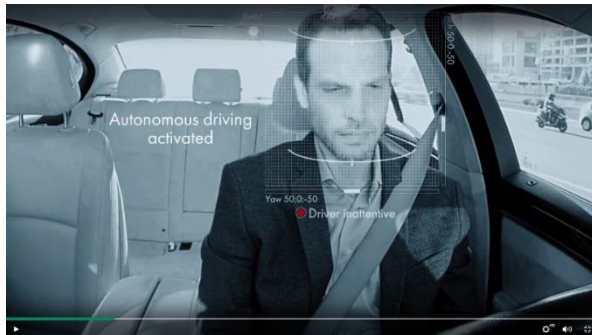

### More Information

- There is a video demonstration on the upper right corner of the company’s website of its driver monitoring system: <https://www.jabil.com/industries/automotive-electronics-components/advanced-driver-assistance-monitoring-systems.html>

## 166. Joyson Safety Driver Monitoring

Joyson Safety is a partner with Cippa driver monitoring system. Joyson Safety helps with the camera hardware for the Cippa system. The camera looks at a person’s eye and analyzes a person head movement and detects drowsy or distracted driving. The image on the right is of Joyson Safety driver monitoring system.



### More Information

- Joyson Safety: <https://www.joysonafety.com/en/technology/integrated-safety-solutions/vision-radar-systems/>
- Video: [https://www.joysonafety.com/media/jss\\_v\\_r\\_dms.mp4](https://www.joysonafety.com/media/jss_v_r_dms.mp4)

<sup>169</sup> “Keeping Drivers Awake, Alert, and Alive,” Jabil. <https://www.jabil.com/industries/automotive-electronics-components/advanced-driver-assistance-monitoring-systems.html>

## 167. Joyson Safety Patent: System and method for disabling a vehicle

The Joyson Safety Patent filed in 2012 for a seat based and touch based alcohol sensors.

The Sketch on the right is of the Patent. Figure 2 is described as:

A blood alcohol detection system is provided. The blood alcohol detecting system includes a finger sensor 50 for sensing the finger of the vehicle driver. The results of the interaction between the finger sensor and the driver's finger are analyzed by a controller to determine the blood alcohol concentration of the driver. The sensor and alcohol detecting system may employ any of a number of known technologies. For example, the alcohol detection systems disclosed in U.S. Patent Documents Nos. 6,229,908, 7,413,047 and 2010/0036592 may be employed. Also, the scope of the present invention is not limited to the use of a finger sensor. For example, as disclosed in U.S. Pat. No. 7,413,047 the sensor may rely on the interaction between the driver's hand and the steering wheel of the vehicle.

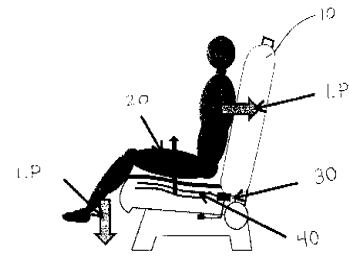

FIG. 1

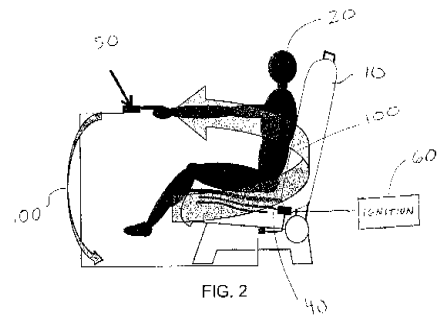

FIG. 2

FIG. 4, pictured right, is from the Patent to shows a driver facing camera mounted close to the alcohol detection system.

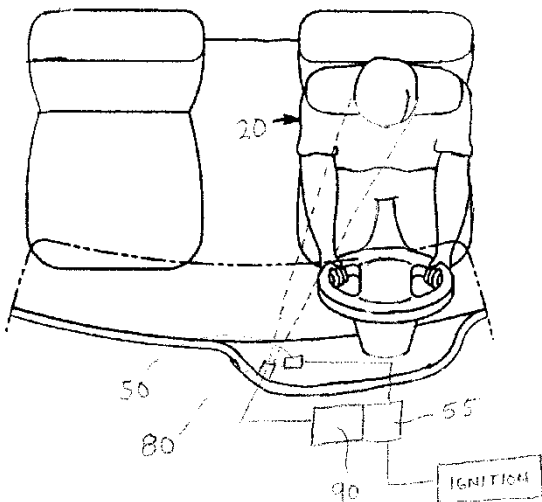

FIG. 4

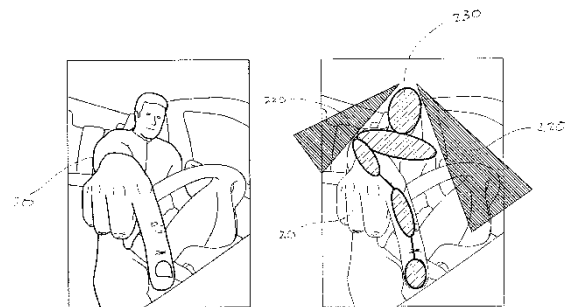

FIG. 5

FIG. 6

FIG 6 shows “the image capturing system is mounted to capture an image of the driver 20. A rear facing camera 80 is positioned proximate to location of the blood alcohol detection sensor 50. The system includes both a camera and signal processing electronics 90. The signal processing electronics 90 typically includes a microprocessor or controller contained in a module. The system is configured to determine whether the hand presented at

the alcohol sensing detector 50, is in fact connected to the person in the driver seat.”<sup>170</sup>

<sup>170</sup> “System and method for disabling a vehicle,” Joyson Safety. Patent US20120228047A1. Filed March 8, 2012. <https://patents.google.com/patent/US20120228047A1>

## 168. Lear driver monitoring

Seat monitoring system that can determine a heart rate or a driver's breathing. Lear says "Our non-intrusive sensor technology utilizes biometrics to detect stress, drowsiness and heart rate variability, and could activate seat treatments including heat and massage function, as well as transmit critical data via secure wireless communication to a health care professional or family member."<sup>171</sup>

### More Information

- Video of technology: <https://www.lear.com/Site/Technology/Intu.aspx>

## 169. Lear Patent: Distractedness sensing system

The Lear Patent filed in 2020 is for a seat sensor driver monitoring system.

FIG. 3A, shown below from the Patent, shows the process on how distractedness could be determining using the technology. The Patent says, "the sensor array 303 can monitor a driver or an occupant of the vehicle seat. The monitoring can include EDP sensing using the contactless sensors 150. The EDP signals are used to detect a distraction state of the driver."<sup>172</sup>

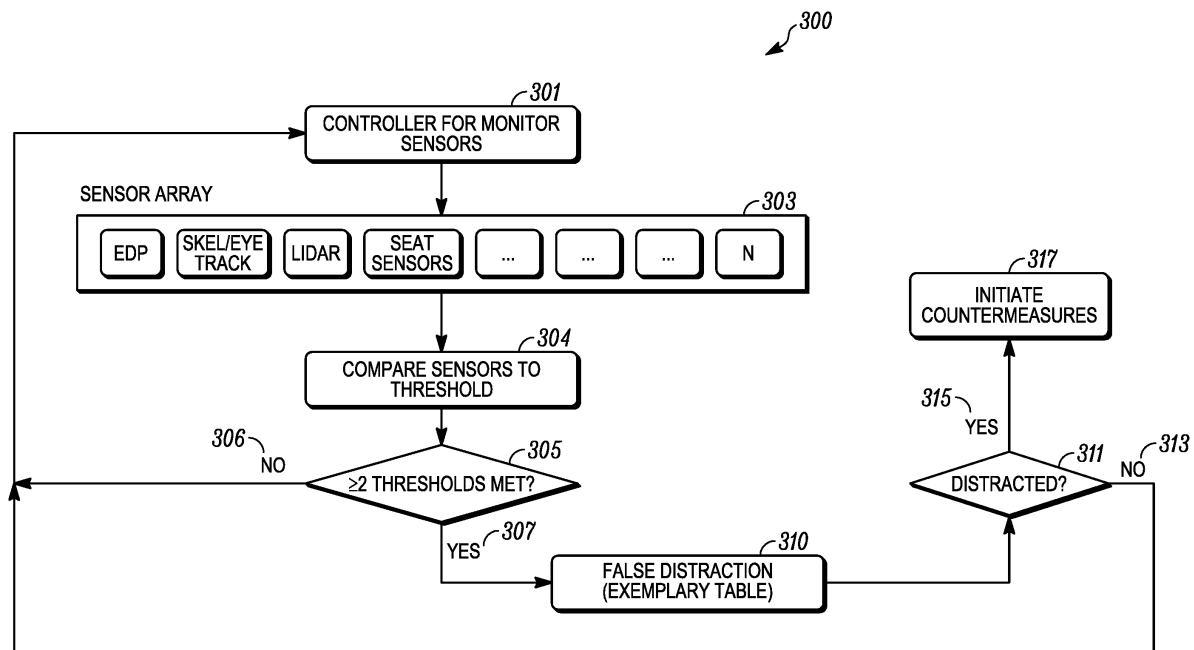

FIG. 3A

<sup>171</sup> "INTU," Lear. <https://www.lear.com/technology/seating/advanced-seating-innovation/intu>

<sup>172</sup> "Distractedness sensing system," Lear. Patent US20210009149A1. Filed September 25, 2020. <https://patents.google.com/patent/US20210009149A1>

## 170. Leopold Kostal driver monitoring

A 2017 presentation details possible Leopold Kostal driver monitoring system that is camera and voice based. The camera measures the face and eye movement of the driver.<sup>173</sup>

Kostal describes their technology as “This camera operates in the interior of the vehicle and checks the driver’s head and eyelid positions, thus detecting his or her attention level. In future, where piloted steering is installed, this will allow the driver to take his hands from the steering wheel.”<sup>174</sup>

## 171. LG Electronics Patent: Driver assistance apparatus

The 2016 LG Electronics Patent is for air and touch sensor for alcohol and could switch the vehicle to self-driving mode depending on the state of the driver. The images below are from the Patent which shows that if the driver is drunk, the vehicle would switch to autonomous mode.<sup>175</sup>

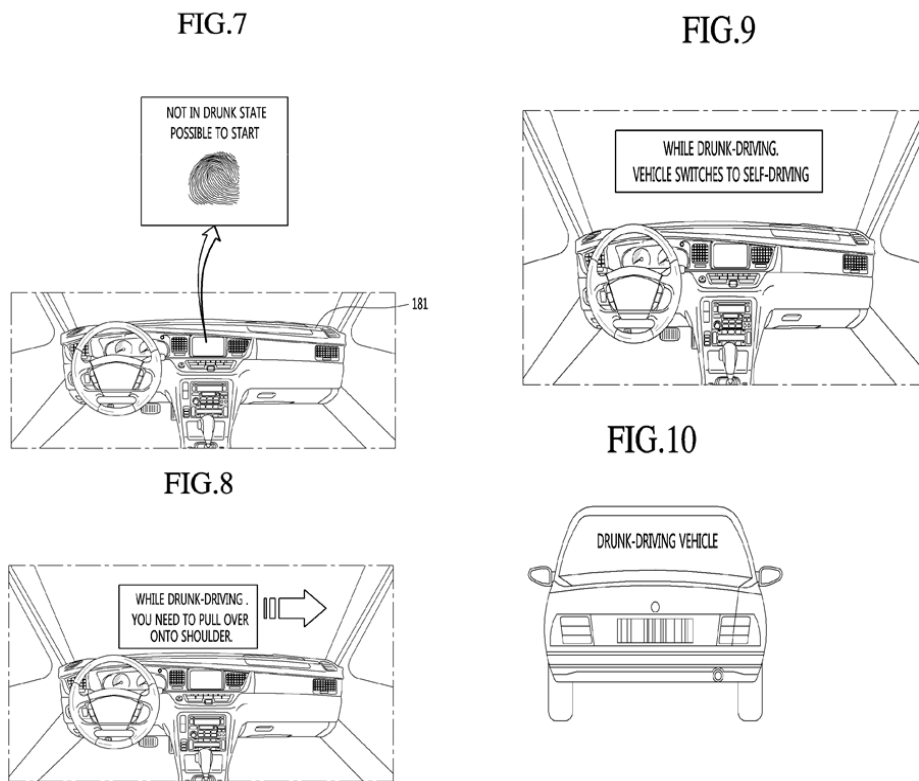

<sup>173</sup> “Driver Monitoring: A Deep Learning Approach for Gaze Estimation” GPU Technology Conference 2017. <https://on-demand.gputechconf.com/gtc/2017/presentation/s7624-cornelius-wefelscheid-driver-monitoring-a-deep-learning-approach-for-gaze.pdf>

<sup>174</sup> “Driver Assistance,” Kostal. <https://www.kostal-automobil-elektrik.com/en-gb/produkte/mechatronik-module/fahrerassistenz>

<sup>175</sup> “Driver assistance apparatus,” LG Electronics. Patent US10435027B2. Filed March 18, 2016. <https://patents.google.com/patent/US10435027B2/>



## 172. LG Innotek Patent: Vehicle Safe Starting Device

FIG. 4

The LG Innotek Patent filed in 2016 is for a touch-based alcohol sensor system. The Patent states “a touch part physically contacting skin of a man; an optical sensor part projecting an electromagnetic wave of a predetermined frequency region to the skin of a man contacted by the touch part and receiving a reflective signal of the projected electromagnetic wave; and an analysis part analyzing the reflective signal and outputting a start control signal as a result of the analysis.”<sup>176</sup>

The sketch on the right is from the Patent and shows how the system is designed to work.

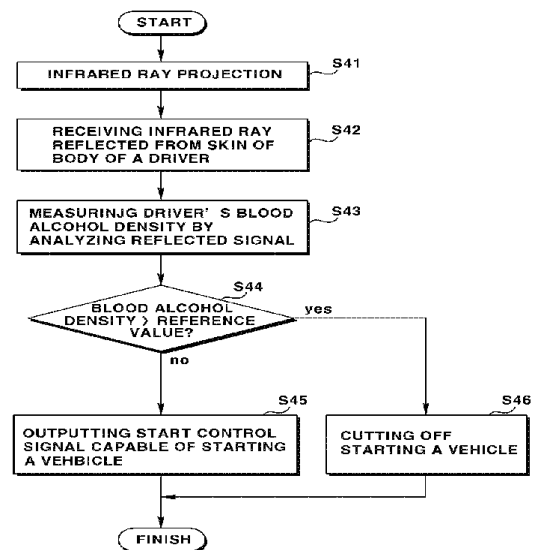

## 173. Magna driver monitoring

Monitors driver's gaze and level of alertness. Magna says “The technology can not only tell when a driver is not paying attention, but makes allowances for normal actions, such as looking in the side-view mirrors.”<sup>177</sup>

### More Information

- Magna Takes Aim at Distracted Driving: <https://www.magna.com/innovation/driven-people-driving-change/article/magna-technology-takes-aim-at-distracted-driving>.

## 174. Magna Patent: Vehicular driver monitoring system using breath sensor

The Magna Patent filed in 2020 monitors for driver drowsiness or distraction by monitoring the breathing of the driver.<sup>178</sup>

<sup>176</sup> “Vehicle Safe Starting Device,” LG Innotek. Patent US20180037113A1. Filed February 25, 2016. <https://patents.google.com/patent/US20180037113A1>

<sup>177</sup> “Magna Technology Takes Aim at Distracted Driving,” Magna. <https://www.magna.com/innovation/driven-people-driving-change/article/magna-technology-takes-aim-at-distracted-driving>

<sup>178</sup> “Vehicular driver monitoring system using breath sensor,” Magna. Patent US20200283001A1. Filed March 4, 2020. <https://patents.google.com/patent/US20200283001A1/en?q=+20200283001>

## 175. Mitsubishi Electric driver monitoring

Camera and other system to monitor the face and body of the driver. Mitsubishi Electric says the technology:

- 1) Monitoring both driver and front passenger for enhanced safety and convenience.
  - Monitor both the driver and the front passenger to provide automated assistance, such as adjusting the air conditioning or audio entertainment system.
  - Recognition of hand gestures of both the driver and the front passenger to control various in-vehicle devices.
  - To-be-developed detection of not only heads but also upper bodies to detect potentially dangerous behavior, such as abnormal postures including slumping over or collapsing backwards.<sup>179</sup>

The company says portions of this technology would be ready by 2018. Images below are from Mitsubishi Electric of their driver monitoring system.

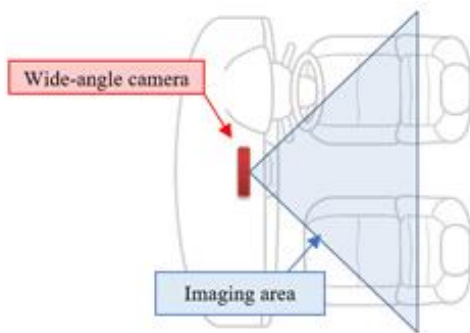

Flexible installation of camera position



Monitoring both driver and front passenger

### More Information

- “Mitsubishi Electric Unveils EMIRAI S concept car fitted with novel HMI / biotech sensors,” October 10, 2019. <https://optics.org/press/4475>.
- “How DMS is Creating the Future of Mobility — Giving Drivers a Taste of ‘Omotenashi,’” January 10, 2020. [https://www.mitsubishielectric.com/en/our-stories/article/xx\\_ww\\_f\\_in2001\\_02.html?fbclid=IwAR1cS4iqxCN\\_SYB6kYTOdhMSeAHdg\\_VgXw6ImDfP6u\\_ZABwnYnERKurUWcpY](https://www.mitsubishielectric.com/en/our-stories/article/xx_ww_f_in2001_02.html?fbclid=IwAR1cS4iqxCN_SYB6kYTOdhMSeAHdg_VgXw6ImDfP6u_ZABwnYnERKurUWcpY)
- Video: <https://www.facebook.com/watch/?v=853865211709762>

<sup>179</sup> “Mitsubishi Electric Develops Driver Monitoring System with Wide-angle Camera,” Mitsubishi Electric. October 5, 2017. <https://www.mitsubishielectric.com/news/2017/1005.html>.

## 176. Panasonic driver monitoring system

Drowsy driver face monitoring systems that also uses Artificial Intelligence. The company notes that the technology does the following:

Panasonic's drowsiness-detection technology identifies and predicts a person's level of drowsiness by accurately measuring the driver's states without physical contact, including blinking features and facial expressions, etc. captured by an in-vehicle camera, and processing these signals using artificial intelligence. Further, using measurement data from the in-vehicle environment, such as heat loss from the driver, Panasonic's new technology also predicts transitions in the driver's drowsiness level. The technology also combines a thermal sensation monitoring function, allowing the driver to stay comfortably awake while driving.

An emotion detection system is embedded within this driver monitoring demonstration. Using near-infrared camera technology, the system collects facial feature points from the driver to determine his/her state of emotions, such as irritation, happiness or fear, and current drowsiness level.

Panasonic's newly developed technology, with 22 patents on file, is suitable for applications in human and environment monitoring systems for use in such places as private and commercial vehicles, offices and educational institutions; drowsiness-prediction systems; and drowsiness-control systems for keeping people awake.<sup>180</sup>

### More Information

- "Panasonic Develops Drowsiness-Control Technology by Detecting and Predicting Driver's Level of Drowsiness," Panasonic. July 27, 2017. <https://news.panasonic.com/global/press/data/2017/07/en170727-3/en170727-3.html>
- Video: <https://www.youtube.com/watch?v=CT4qnpMnrXg>

## 177. Panasonic Patent: Alcohol detection system

The Panasonic Patent filed in 2008 is for a steering wheel-based touch alcohol sensor.<sup>181</sup>

The sketch on the right is from the Patent and represents the alcohol sensors on the steering wheel.

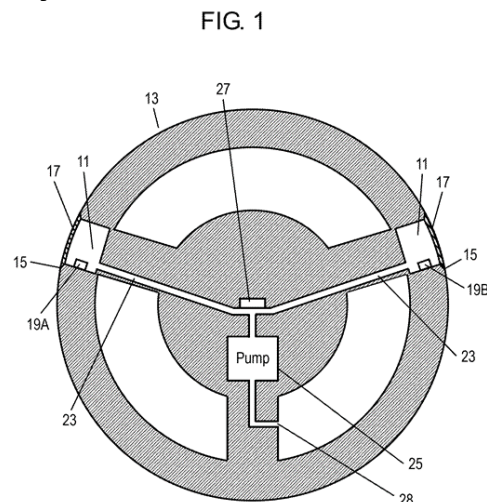

<sup>180</sup> "Vehicle Sensor," Panasonic. <https://na.panasonic.com/us/automotive-solutions/vision-sensing-u>

<sup>181</sup> "Alcohol detection system," Panasonic. Patent US7911350B2. Filed June 16, 2008. <https://patents.google.com/patent/US7911350B2/>

## 178. Samsung driver monitoring

Samsung is listed a partner with Cippa. It appears to be developing facial and body monitoring technology including that of measuring a person's heart-rate. It is unclear if that technology is also part of Cippa.

On their website, it says "The Driver Monitoring System will also transmit a warning sound if it detects dangerous behavior, such as driving while drowsy or sending text messages behind the wheel."<sup>182</sup> Below are images of the Samsung driver monitoring system.

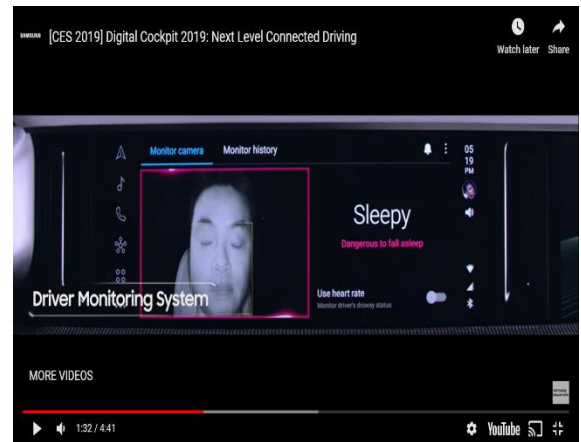
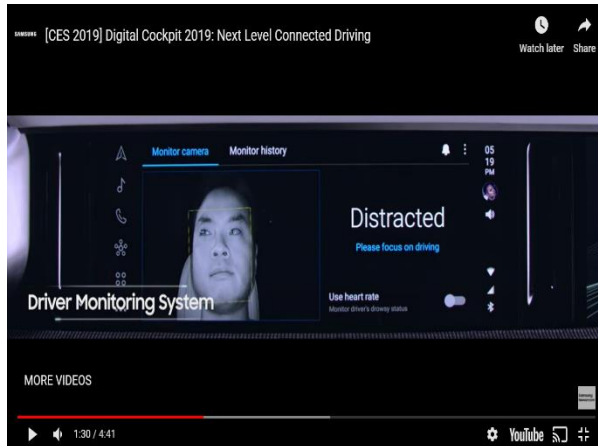

## 179. Sony driver monitoring

Listed a partner with Cippa. The technology listed on Sony's website may be entirely different to Cippa's technology. On Sony's website it says "Inside the cabin, sensors will monitor the condition of drivers and passengers. The facial expression and body movement of drivers will be used to gauge their concentration and fatigue levels, sending out alerts as necessary."<sup>183</sup>

The Cippa platform has a range of partners. The technology outlined by Sony may be part of the Cippa system or may be something different.

### More Information

- Possible Patent filed in 2016 by Sony: US10768617B2.  
<https://patents.google.com/patent/US10768617B2/en?q=10471969>

<sup>182</sup> "Digital Cockpit 2019: Next Level Connected Driving," Samsung. January 8, 2019.

<https://news.samsung.com/global/video-digital-cockpit-2019-next-level-connected-driving>

<sup>183</sup> "Safety," Sony. <https://www.sony.com/en/SonyInfo/vision-s/safety.html>

## 180. Sumitomo Riko driver monitoring

The “Smart Rubber” sensor is used for seat monitoring of: heart rate, drowsiness and breathing. The image on the right is an image from Sumitomo Riko’s website on the technology.<sup>184</sup>

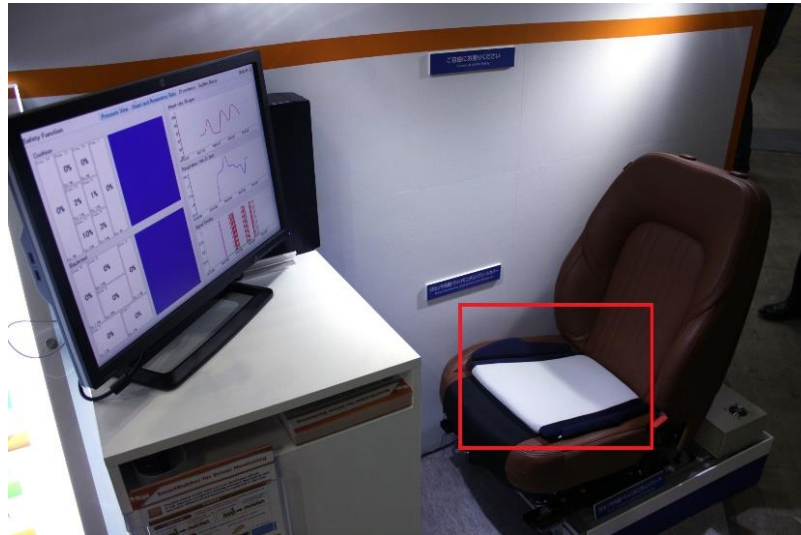

### More Information

- Sumitomo Riko DMS Presentation from 2018: [https://www.sumitomoriko.co.jp/wordpress/wp-content/uploads/sites/4/2018/05/sumitomoriko\\_DMS\\_E.pdf](https://www.sumitomoriko.co.jp/wordpress/wp-content/uploads/sites/4/2018/05/sumitomoriko_DMS_E.pdf).

## 181. Toyota Gosei driver monitoring

Steering wheel camera based monitoring. A 2018 press release from the company said “A camera in the steering wheel monitors the driver’s face and alerts the driver when inattention or drowsiness are detected”<sup>185</sup>

### More Information

- “Toyota Gosei to Launch Truck Steering Wheels that Warn Drivers of Inattention or Drowsiness,” January 30, 2018. <https://www.toyoda-gosei.com/news/detail/?id=174>

<sup>184</sup> “Sumitomo Riko Exhibiting at Automotive Engineering Exposition 2019 Yokohama,” Sumitomo Riko. <https://www.sumitomoriko.co.jp/english/sumitomo-riko-exhibiting-at-automotive-engineering-exposition-2019-yokohama-2/>

<sup>185</sup> “Toyota Gosei Accelerates Development of Steering Wheels with HMI Functions,” Toyota Gosei. November 28, 2018. <https://www.toyoda-gosei.com/news/detail/?id=199>.

## 182. Toyota Boshoku

The concept by Toyota Boshoku and four other companies within the Toyota group is a seat based and cabin based monitoring of the driver and other occupants. The driver monitoring as the “the system incorporates a camera and a seat sensor which can detect your eye position, size and posture. This way your seat and seatbelt positions can be optimized automatically.”

If the system determines a driver is drowsy, the Active Driver Engagement system will “comfortably keep you engaged with nostalgic music and vibrations.”<sup>186</sup>

The image on the right is of the Active Driver Engagement System. The MX 191 system from Toyota Boshoku is an “An interior space concept that supports level 3 to 4 autonomous cars. The MX191 concept is created on the theme of “more comfort, more safety, and more enjoyment.”<sup>187</sup>



## 183. Toyota Boshoku Drowsiness Suppression Seat System

The Drowsiness Suppression Seat System “detects signs of drowsiness and prevents dozing, leveraging the company’s strengths in physiological data-based technologies to control five human senses.”<sup>188</sup>

## 184. TS Tech monitoring system

A seat-based monitoring system. TS Tech says “The seat uses a sensor to monitor changes in respiration, including deep breathing or yawns, to detect a state of low arousal such as drowsiness. A vibration motor in the seat will alert the driver when drowsiness is detected.” The company is “continuing development of this technology as it works towards mass production.”<sup>189</sup>

<sup>186</sup> “Aces,” Toyota Boshoku. <https://www.toyota-boshoku.com/global/special/ces2019/aces.html>

<sup>187</sup> “MX 191,” Toyota Boshoku. <https://www.toyota-boshoku.com/global/special/ces2020/mx191.html>

<sup>188</sup> “Toyota Boshoku Participates in Autonomous Driving Field Test at Central Japan International Airport with Drowsiness Suppression Seat System,” Toyota Boshoku. January 22, 2021. <https://www.toyota-boshoku.com/global/news/release/detail.php?id=7323>

<sup>189</sup> “Utilizing the latest facilities and advanced technologies, safety performance is undergoing further evolution,” TS Tech. <https://www.tstech.co.jp/english/development/technology/safety.html>

## 185. Valeo driver monitoring

Face and eye based camera monitoring system. Valeo says the system “The purpose of the Driver Monitoring system is to alert the driver when signs of drowsiness or distraction are detected. Other applications for the system are also possible, such as driver identification and control functions using the eyes. These developments will contribute to heightened safety and more intuitive use of the new generation of driver assistance functions.”<sup>190</sup>

The image below is from Valeo’s driver monitoring system.

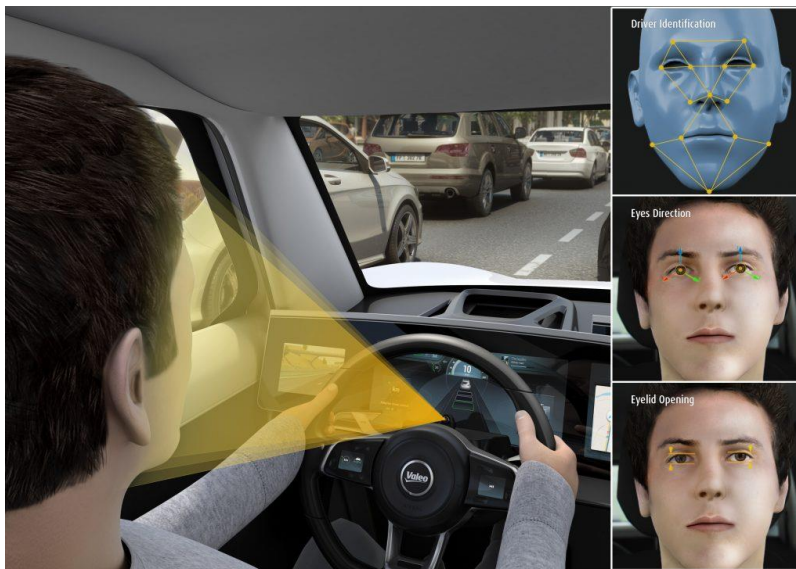

### More Information

- Video of technology: <https://www.trendhunter.com/trends/safran-and-valeo>

---

<sup>190</sup> “Driver Monitoring,” Valeo. <https://www.valeo.com/en/driver-monitoring/>

## 186. Valeo Patent: Method and apparatus for in-vehicle impairment detection with driver verification

The Valeo Patent filed in 2018 is for technology that monitors a driver through a camera and other sensors and can determine an alcohol impairment level based off touch sensors.<sup>191</sup>

Although this technology does have a component to verify the identity of a driver. It is mainly focused on determining the alcohol level through a touch-based method, where a driver puts his hand on the hand rest to determine the alcohol level. It is unclear if there are alcohol sensors elsewhere.

The sketch to the right is from the Patent on how the system operates. The sketch below is of the touch-based sensor from the Patent.

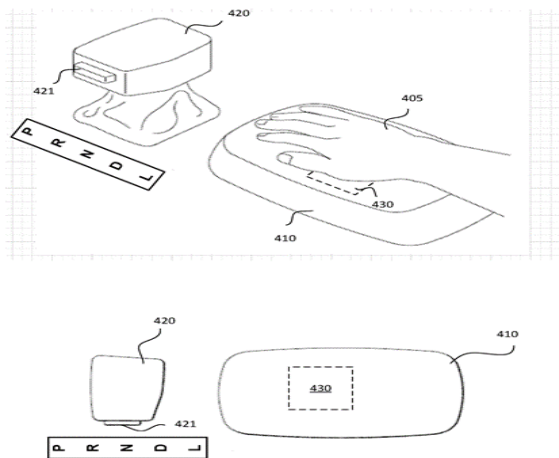

FIG. 4

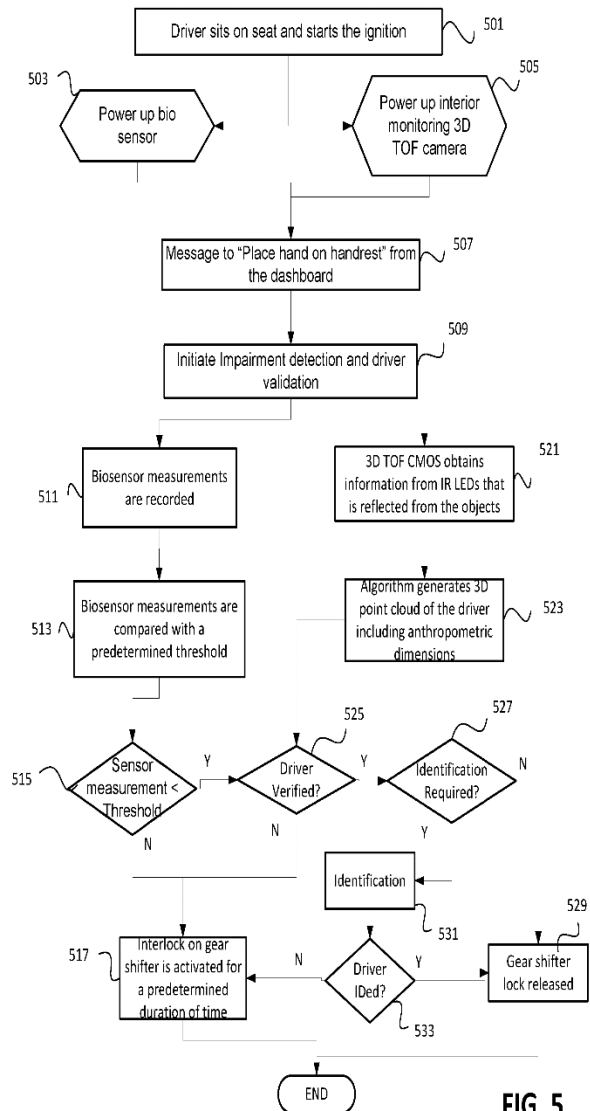

FIG. 5

<sup>191</sup> "Method and apparatus for in-vehicle impairment detection with driver verification," Valeo. Patent US20200122731A1. Filed October 19, 2018. <https://patents.google.com/patent/US20200122731A1/en?q=20200122731>



## 187. Visteon driver monitoring

Camera based monitoring system that uses Artificial Intelligence focusing on face, head and eyes. Visteon describes their technology as:

How do we ensure the person behind the wheel is prepared to drive? A driver monitoring system (DMS) identifies the drowsiness and distraction level of the driver. Visteon's infrared camera-based solution is capable of facial recognition and incorporates artificial intelligence to monitor driver distraction, drowsiness, emotion, and head and eye gaze. Our range of solutions can increase vehicle safety today, while allowing for a scalable approach as new autonomous features are deployed to comply with safety regulations.<sup>192</sup>

The image on the right is from Visteon's website on this technology.



### More Information

- [Visteon White Paper: Camera-based driver monitoring system using deep learning.](https://www.visteon.com/wp-content/uploads/2019/04/camera-based-driver-monitoring-system-using-deep-learning.pdf)
- Video: <https://www.visteon.com/newsroom/white-paper-camera-based-driver-monitoring-deep-learning/>

## 188. Yanfeng driver monitoring

Facial recognition system monitoring. Yanfeng says "Using facial recognition technology, the system can read facial fatigue and emotional cues, alerting or accommodating the driver with ambient lighting changes. Detectable sentiments or expressions include joy, smiling, sadness, anger, yawning, or sleepiness."<sup>193</sup>

## 189. Yazaki Patent: Driver monitoring device

The Yazaki Patent filed in 1996 originally in Japan relates to driver monitoring by using a camera.<sup>194</sup> It appears the Patent in the United States expired in 2017.

<sup>192</sup> "Interior Sensing," Visteon. <https://www.visteon.com/technology/interior-sensing/>

<sup>193</sup> "touchIN provides an Interactive and Responsive User Experience," Yanfeng. September 4, 2019. <https://www.yfai.com/en/touchin-provides-interactive-and-responsive-user-experience>

<sup>194</sup> "Driver monitoring device," Yazaki. Patent JPH10960A. Filed June 12, 1996. <https://patents.google.com/patent/JPH10960A/en>

## 190. ZF Friedrichshafen driver monitoring

The ZF coPilot monitors the driver for unsafe driving and interacts with autonomous vehicle driving. ZF Friedrichshafen says “were the driver to become distracted, their focus too far removed from traffic on the road or show signs of drowsiness. In addition to intelligent route guidance including “MyRoute” – a map function that recognizes repeat routes – the ZF coPILOT is also equipped with voice recognition so that the driver can conveniently enable, operate and disable driver assistance functions via voice commands, if they wish to drive manually.”<sup>195</sup>

### More Information

- “ZF Sensor Power: Autonomous Driving With All the Senses,” ZF Friedrichshafen AG. January 7, 2019. <https://news.cision.com/zf/r/zf-sensor-power—autonomous-driving-with-all-the-senses,c2713081>

---

<sup>195</sup> “ZF coPILOT Enables Enhanced Safety and Driving Comfort,” ZF Friedrichshafen. [https://press.zf.com/press/en/releases/release\\_6848.html](https://press.zf.com/press/en/releases/release_6848.html)

## Tier 2 Auto Suppliers, Other: Driving Performance Monitoring, Driver Monitoring and Passive Alcohol Detection Safety Technologies

There are over 51 systems developed or in development from Tier 2 or other auto suppliers relating to: driving performance monitoring, driver monitoring, and passive alcohol detection. This section will go through these technologies.

Tier 2, Other	Driving Performance Monitoring (e.g., Lane Assist, driver attention monitor)	Driver Monitoring (e.g., eyes, head)	Passive Breath or Touch Alcohol Detection	Total
Abto		1		1
ADAM		1		1
Affectiva		1		1
Ambarella		1		1
American Vehicular Sciences		1		1
AMS		1		1
Apple			1	1
Autocruis Technology		1		1
ACTS			3	3
Baidu Apollo		1		1
CardioID		1		1
Cipia		1		1
DADSS			1	1
DTS Autosense		1		1
Delta Tooling			1	1
Eyegaze		1		1
Gaze Sense		1		1
FutureWei Technologies		1		1
Harman		1		1
HID Global			2	2
Joynext		1		1
Lime Scooters	1			1
Melexis		1		1
Mobile Eye	1			1
Nauto, Inc.	1			1
NVIDIA Corporation		1		1
NXP		1		1
Optalert		1		1
Pioneer		1		1
Plessey Semiconductors		1		1
PrevciDrugs		1		1
Primax		1		1
Seeing Machines		1		1
Senseair			2	2
SpeedGauge		1		1
Sight hound		1		1
Smart Eye		1		1
Sober steering			1	1
SRI		1		1
ST		1		1
Tata Elxsi		1		1
TruTouch			1	1
Thunder Power			1	1
Veoneer		1		1
Wipro		1		1
Xandar Kardian		1		1
Xperi		1		1
<b>Total</b>	<b>3</b>	<b>35</b>	<b>13</b>	<b>51</b>

## 191. Abto Software

An eye and head-based monitoring system for fatigue.<sup>196</sup>

The image on the right is from a Abto YouTube video.

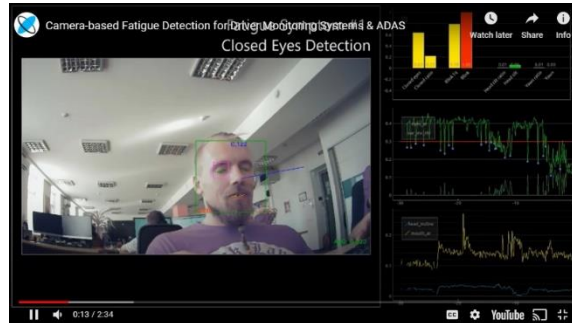

## 192. Adam

Eye based and Artificial Intelligence monitoring of a driver. Their company says of the technology:

ADAM DETECT and ENHANCE are software based-solutions that can be integrated on-top of any existing DMS or a stand-alone solution. Whereas traditional DMS look at the physical attributes, the ADAM platform can understand the real-time cognition state of the driver. Our architecture enables robustness and scalability to provide highest possible safety for any system with a Human-in-the-Loop.<sup>197</sup>

### More Information

- Video of technology: [https://drive.google.com/file/d/1PRii2qpwVHcwfcIDAAtc\\_IWdDHOUWVYe/view](https://drive.google.com/file/d/1PRii2qpwVHcwfcIDAAtc_IWdDHOUWVYe/view)

## 193. Affectiva

Face and voice based monitoring system that also uses Artificial Intelligence. Affectiva says their technology “takes driver state monitoring to the next level, analyzing both face and voice for levels of driver impairment caused by physical distraction, mental distraction, drowsiness and more.”<sup>198</sup>

## 194. Ambarella

Driver Monitoring system integration and partner with Cippa. Ambarella integrates driver monitoring systems. Ambarella’s website says “Ambarella’s automotive solutions are designed for both human and computer vision, combining high-resolution imaging and neural network processing into a single, low-power embedded platform. We specialize in edge devices with low latency, high efficiency and exceptional performance, including front ADAS cameras, smart electronic mirrors, drive recorders, fleet management solutions, DMS/OMS, and more.”<sup>199</sup>

<sup>196</sup> “Real-time Fatigue Detection for Driver Monitoring Systems,” Abto Software.

<https://www.abtosoftware.com/blog/fatigue-detection-for-driver-monitoring-systems>

<sup>197</sup> “Adam for OEM,” Adam. <https://www.adam-cogtec.com/adam-for-oems>.

<sup>198</sup> “Affectiva Automotive AI for Driver Monitoring Systems,” Affectiva.

<https://www.affectiva.com/product/affectiva-automotive-ai-for-driver-monitoring-solutions/>

<sup>199</sup> “A new standard in automotive,” Ambarella. <https://www.ambarella.com/applications/automotive/>

## 195. American Vehicular Sciences Patent: Driver fatigue monitoring system and method

The Patent is for technology that monitors a driver for drowsiness or “otherwise unable to operate the vehicle.” The technology also utilizes other sensors to determine a driver’s state.

The technology could also determine if the driver is drunk through “The vehicle interior monitoring system could also determine that the object is an adult, that he is drunk and that he is out of position relative to the airbag.”<sup>200</sup>

The sketches to the right are from the Patent. Figure 6 shows where various sensors for could be placed including that for a heart sensor.

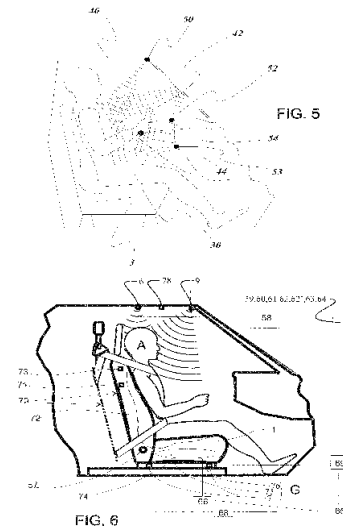

## 196. AMS

Measures eye and steering movement. According to AMS:

In all but fully autonomous vehicles (classified as ‘Level 5’ autonomy), the driver’s ability to take back control of the vehicle must be monitored continuously. For this function, 3D optical sensing is already in use in vehicles to create depth maps which reveal the driver’s posture, and show where the driver is looking – data which can be used to determine their state of readiness to assume control of the vehicle. 3D sensing can also be used for driver identification and access control.

3D sensing solutions in use today and under development make use of ams technologies such as time-to-digital converters for time-of-flight measurement, and illumination solutions for structured light and adapted stereo vision systems.<sup>201</sup>

### More Information

- Video of technology: <https://www.youtube.com/embed/5zknGuXNXwQ?rel=0&fs=1>

<sup>200</sup> “Driver fatigue monitoring system and method,” American Vehicular Sciences. Patent US9129505B2. Filed December 10, 2012. <https://patents.google.com/patent/US9129505B2/en>

<sup>201</sup> “ams Automotive Solutions,” AMS. <https://ams.com/automotive#drivermonitoring>

## 197. Apple Patent: Augmented Safety Restraint

A Patent for a seat belt-based system that can monitor for alcohol impairment and other driver state conditions.

The Patent describes the sketch:

Shows a monitoring feature for an augmented safety restraint 720 that is attached to a seat 718 for use by a passenger 726. The augmented safety restraint 720 can include sensors 734 that are able to measure properties of the passenger 726 and/or the environment. In some embodiments, the sensors 734 are operable to measure the vital signs of the secured passenger 726 such as the passenger's heart rate, breathing rate, temperature, CO level, blood alcohol content, etc. This information can be used to document the passenger's health status, stress level, and emotional well-being for various purposes (e.g., diagnostic, research, investigations, etc.) and falls into the category of activities meant to monitor driver/passenger physical status.<sup>202</sup>

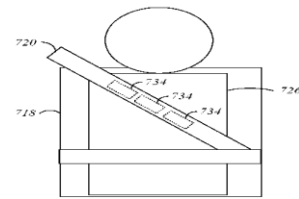

FIG. 7

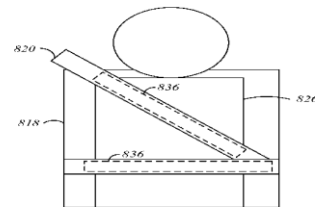

FIG. 8

## 198. Autocruis Technology

Driver monitoring that helps to monitor a driver using sensors intersects with Artificial Intelligence.

The company website says “First driver monitoring system based on deep learning technology in China! The software partner for Driver Monitoring System (DMS) of Bosch China.”<sup>203</sup>

## 199. Automotive Coalition for Traffic Safety Patent: System for non-invasive measurement of an analyte in a vehicle driver

The 2018 Patent is for a touch based sensor that uses optical sensors that can determine alcohol concentration.<sup>204</sup>

## 200. Automotive Coalition for Traffic Safety Patent: Sensor system for passive in-vehicle breath alcohol estimation

The 2016 Patent is for passive alcohol breath-based alcohol sensors.<sup>205</sup>

<sup>202</sup> “Augmented safety restraint,” Apple. Patent US10189434B1. Filed September 9, 2019.

<https://patents.google.com/patent/US10189434B1/en?q=10471969>

<sup>203</sup> “Driver Monitoring Systems,” Autocruis. <http://www.autocruis.com/en/Drivermonitoringsystem/>

<sup>204</sup> “System for non-invasive measurement of an analyte in a vehicle driver,” ACTS. Patent US20190275886A1. Filed October 16, 2018. <https://patents.google.com/patent/US20190275886A1/en>

<sup>205</sup> “Sensor system for passive in-vehicle breath alcohol estimation,” ACTS. Patent US20170274768A1. Filed December 23, 2016. <https://patents.google.com/patent/US20170274768A1>

## 201. Automotive Coalition for Traffic Safety Patent: System and method for controlling operation of a vehicle using an alcohol detection apparatus

The 2019 Patent for a breath based alcohol sensor that can also detect a person's voice. The Patent says:

The technology utilizes a speech recognition system that can understand a driver's voice command such as "start car". The alcohol measurement is taken in real-time and synchronized to the driver giving the voice command. If the system detects a BAC measurement above a predetermined threshold, the vehicle is disabled or prevented from moving. The system may give warnings if the measurement is above a predetermined threshold.<sup>206</sup>

## 202. Baidu Apollo

Face based driver monitoring that looks for fatigue.<sup>207</sup>

### More Information

- Video: <https://www.youtube.com/watch?v=HocfBmg4qgo>
- Video: [https://twitter.com/baidu\\_inc/status/1146739566486757376?lang=en](https://twitter.com/baidu_inc/status/1146739566486757376?lang=en)

## 203. CardiID

The system uses a steering wheel to monitor for drowsiness and heart related problems. CardiID says "It's an Advanced Driver Assistance System that acquires the electrocardiogram (ECG) from the driver's hands to continuously detect drowsiness, cardiac health problems and biometric identity recognition."<sup>208</sup>

---

<sup>206</sup> "System and method for controlling operation of a vehicle using an alcohol detection apparatus," ACTS. Patent US20200101982A1. Filed September 10, 2019. <https://patents.google.com/patent/US20200101982A1>

<sup>207</sup> "Pilot Driver Monitoring," Baidu. <https://apollo.auto/platform/dueros/competencies.html#fatigue>

<sup>208</sup> "What is Cardiwheel?" CardiID. <https://www.cardio-id.com/cardiowheel>

## 204. Cipia

This DMS measures eye and head movement using a camera to determine distraction and drowsiness.<sup>209</sup> The images to the right are from Cipia's video of the technology on YouTube.

Cipia has multiple partners of Tier 1 suppliers and an automaker (Seat). The technology is available to be part in new vehicles, aftermarket for fleets.

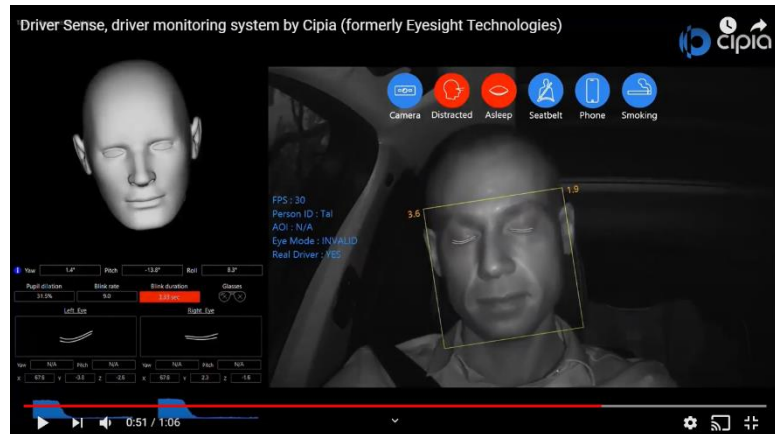

### More Information

- Video: <https://youtu.be/Qp5mAKQ7KtQ>

## 205. Driver Alcohol Detection System for Safety

The Driver Alcohol Detection System for Safety began with federal government funding in 2008, which led to a cooperative agreement between the National Highway Traffic Safety Administration (NHTSA) and the auto industry. The research project focused on the creation of a proof-of-concept prototype to determine which type of alcohol detection technology was most promising for vehicle integration. In 2013 the cooperative agreement was extended to further develop a touch based and breath-based alcohol detection technology. In June 2015, the Department of Transportation unveiled the DADSS vehicle, and auto industry representatives stated at the event the technology could be deployed in less than five years.

### More Information

- Driver Alcohol Detection System for Safety: <https://www.dads.org/>.
- “Drunk-Driver Proof Cars Could Be Sold by 2020,” Newsweek. June 8, 2015. <https://www.newsweek.com/drunken-driver-proof-cars-could-be-sold-2020-340706>

## 206. DTS Autosense

Artificial Intelligence that helps with driver and occupant monitoring systems for distracted and drowsy driving. The product discusses Autonomous vehicle technology: “As autonomous cars pave the way to smarter cockpits, in-cabin cognition technologies become increasingly crucial for enhancing the in-car user experience. At all times, a smart car should understand all objects and living beings that are inside the cabin and should be capable of taking actions to improve their safety and driving experience.”<sup>210</sup>

<sup>209</sup> Cipia. <https://cipia.com/>

<sup>210</sup> “DTS Autosense,” DTS. <https://dts.com/autosense/>



## 207. Delta Tooling Patent: Alcohol-drinking detecting system and computer program

A Delta Tooling Patent filed in 2010 is for alcohol detection that appears located in a seat.<sup>211</sup>

The sketch to the right is from the Patent which shows biosensors in the Seat.

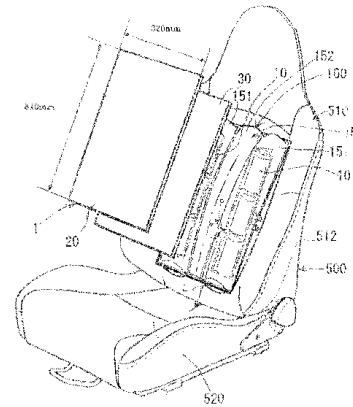

## 208. Eyegaze

The system measures eye movement.<sup>212</sup> Eyegaze is currently not utilized in vehicles but is widely used elsewhere. The company informed MADD device could be adapted to be put in vehicles.

## 209. GazeSense

This driver monitoring system is a combination of Melexis and Eyeare. The joint effort “uses a 3D camera that employs lidar VCSEL range sensing to more accurately identify an occupant's face, eyes, and focus of attention. It performs well in a wider range of lighting conditions than the purely infrared cameras primarily used today. The low-resolution image isn't any more flattering (nobody's looking at it anyway), but it's highly accurate, even at an angle. This opens greater possibilities for positioning of the camera.”<sup>213</sup>

### More Information

- Video: <https://eyeware.tech/gazesense/>

<sup>211</sup> “Alcohol-drinking detecting system and computer program,” Delta Tooling. Patent US9149231B2. Filed May 18, 2010. <https://patents.google.com/patent/US9149231B2>

<sup>212</sup> “Eye Tracking Technology is Making New Cars Safer,” Eyegaze. <https://eyegaze.com/eye-tracking-technology-is-making-new-cars-safer/>

<sup>213</sup> “My Doctor the Car? Future Cars Might Monitor Drivers' Health and Wellbeing,” Motortrend. January 15, 2021. <https://www.motortrend.com/news/driver-health-wellbeing-monitor-car-tech-ces/>

## **210. FutureWei Technologies Patent: Integrated system for detection of driver condition**

Uses “Machine Learning” to evaluate driver condition and the cabin conditions. The Patent states it uses a “machine learning method, the images are processed to classify a condition of the driver and of the interior environment of the vehicle.”<sup>214</sup>

The system intersects with the operation of an autonomous vehicle and also could detect alcohol and drugs in the interior environment of the vehicle.

## **211. Harman**

The system monitors the driver head and eyes and could intersect with autonomous vehicle technology. Harman describes their tech as “HARMAN’s advanced driver monitoring solution uses camera sensors to capture the driver’s most important first-order biometric features, such as gaze, head position and pupil diameter, among many other key facial features. It detects minute fluctuations in pupil diameter and calculates brain activity level, especially high cognitive load.”<sup>215</sup>

## **212. HID Global Patent: White-light spectral biometric sensors**

HID Global Patent filed in 2010 is for a touch-based system that could determine a driver’s alcohol level. The touch-based system could take disable the movement of a vehicle “Ignition of an automobile might be prohibited if a blood-alcohol level exceeds some threshold.”<sup>216</sup>

The system is not specific to the operation of a vehicle but the Patent states that it could be used in that application.

---

<sup>214</sup> “Integrated system for detection of driver condition,” FutureWei Technologies. Patent US10592785B2. Filed July 12, 2017. <https://patents.google.com/patent/US10592785B2>

<sup>215</sup> “Driver and Occupant Monitoring System,” Harman. <https://car.harman.com/solutions/adas/driver-and-occupant-monitoring-system>

<sup>216</sup> “White-light spectral biometric sensors,” HID Global. Patent US8184873B2. Filed June 14, 2010. <https://patents.google.com/patent/US8184873B2/en>

## 213. HID Global Patent: Multispectral biometric sensor

The HID Global Patent filed in 2006 for a touch-based system that could determine a driver's alcohol level.

The image on the right is from the Patent.

FIG. 9A is a flow diagram illustrating a method for using an alcohol. FIG. 9B is a flow diagram illustrating a method for using a combination of an alcohol monitor and a biometric sensor.<sup>217</sup>

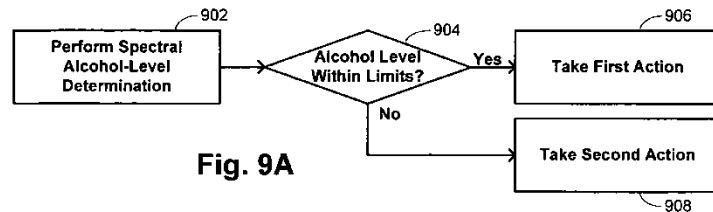

Fig. 9A

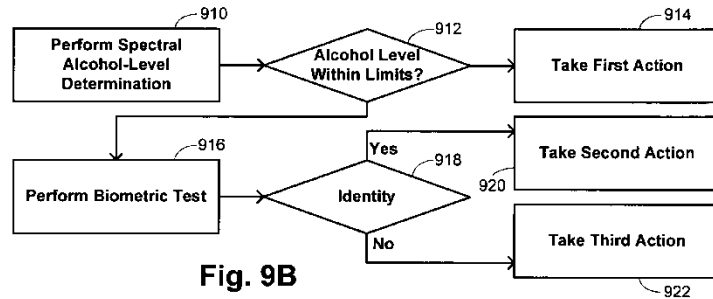

Fig. 9B

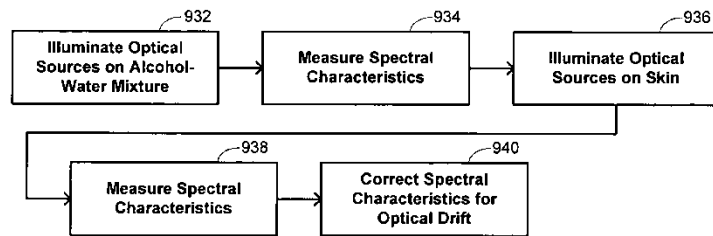

Fig. 9C

## 214. Joynext

The system uses biosensors and other sensors to determine the state of the driver. If the driver is incapacitated, the technology could call for help. Joynext says "JOYNEXT is working on a Driver Monitoring System (DMS), which uses biosensors and an Empathic Assistant to detect the emotional and physical state of the driver and respond accordingly. In extreme emergencies, such as serious health problems, this system could even stop the vehicle and send out an emergency call for assistance."<sup>218</sup>

<sup>217</sup> "Multispectral biometric sensor," HID Global. Patent US7819311B2. Filed May 18, 2006.

<https://patents.google.com/patent/US7819311B2>

<sup>218</sup> "JOYNEXT develops Driver Monitoring System (DMS)," Joynext. <https://www.joynext.com/en/portfolio/driver-adas-and-personalization/>

## 215. Lime Scooters

Lime Scooters is developing technology that can determine drunk driving or other dangerous behavior based off how the scooter movement of the operator. If such behavior is detected, the scooter can be automatically slowed down. Scooters are available in many areas. It is unclear if this technology has been made available.<sup>219</sup>

## 216. Melexis

The system uses Time of Flight technology to assist with driver monitoring systems. The system can help track “fatigue, eye gaze, hands-on wheel,” as well “body, head, face pose and people identification.” On their website, it says “Based on Sony DepthSense™ Time-of-Flight pixel technology, these sensors combine high sensitivity with high sunlight robustness.”<sup>220</sup>

### More Information

- Video of technology: <https://www.youtube.com/watch?v=KNndTqRFyTO>

## 217. Mobile Eye Lane Departure warning

The lane departure warning system claims “A large proportion of crash fatalities and serious injuries are caused by run-off-road crashes, which typically start with unintended lane departure. In fact, 60% of road accident fatalities are due to unintentional lane departure.” Their technology “sends a visual and audio alert when there is a lane deviation without signalling.”<sup>221</sup>

## 218. Nauto Patent: System and method for analysis of driver behavior

The Patent is for a method for analysis of driver behavior including monitoring for distracted driving based off the movement of the steering wheel and other sensors. The Patent states:

In an embodiment, the measure of driver distraction can include a driver distraction score, with a range between 1 and 10, wherein 1 corresponds to a non-distracted state and 10 corresponds to a maximally distracted state. **For example, the score can be based on determined distraction analysis such as a driver distraction categorization (e.g., categorization from a set of categories including highly or overly vigilant, drunk or cognitively impaired, struggling or labored driving, distracted and/or fatigued, and any other suitable category)**<sup>222</sup>

The technology provides information on driver distraction and could also take control of the vehicle to avoid unsafe driving.

---

<sup>219</sup> “Lime working on drunk driving detection feature,” Consumer Affairs. April 18, 2019.

<https://www.consumeraffairs.com/amp/news/lime-working-on-drunk-driving-detection-feature-041819.html>

<sup>220</sup> “Enabling the full potential of automotive 3D ToF imaging,” Melexis. <https://www.melexis.com/en/tech-talks/enabling-potential-automotive-3d-tof-imaging>

<sup>221</sup> “Lane Departure Warning,” Mobile Eye. <https://www.mobileeye.com/uk/fleets/technology/lane-departure-warning/>

<sup>222</sup> “System and method for analysis of driver behavior,” Nauto. Patent US20200198645A1. Filed December 19, 2019. <https://patents.google.com/patent/US20200198645A1/en>

## 219. NVIDIA

Driver monitoring system that uses Artificial Intelligence and other sensors. NVIDIA says of the system:

AI CoPilot provides driver monitoring system using a driver-facing camera, IR LED, and sophisticated deep learning software running on the NVIDIA DRIVE AGX system in the car. This module enables development of applications to ensure drivers stay alert, or take action if a driver is distracted or drowsy. For example, by tracking head and eyes to understand where driver is paying attention, and monitoring blink frequency to assess fatigue and drowsiness. Some of the key capabilities of AI Co-Pilot include: 3 dimensional gaze detection, drowsiness detection, distraction detection and head pose detection.<sup>223</sup>

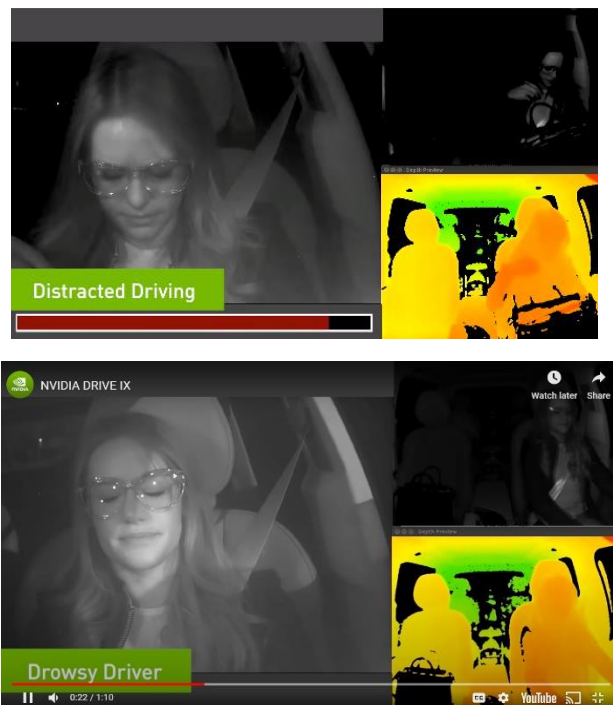

The images above are from the technology's video description.

### More Information

- NVIDIA: <https://nvidianews.nvidia.com/news/nvidia-introduces-drive-autopilot-worlds-first-commercially-available-level-2+-automated-driving-system>
- Video: <https://youtu.be/OKQfTP7D1bM>

---

<sup>223</sup> "NVIDIA Drive IX," Nvidia. <https://developer.nvidia.com/drive/drive-ix>

## 220. NXP

Monitors the face of a driver and other vehicle occupants. NXP says their system “includes a camera-based driver monitoring systems (DMS) pointed at the driver’s face which provides a real-time evaluation of the presence and the state of the driver.” NXP’s website has videos of their technology.<sup>224</sup>

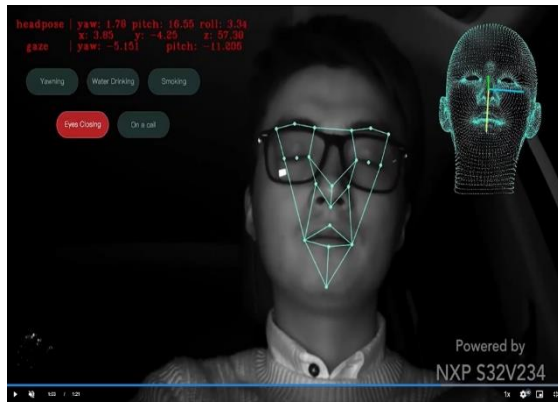

Above are images from NXP. Below is a schematic from NXP on the driver monitoring system.

Driver monitoring system

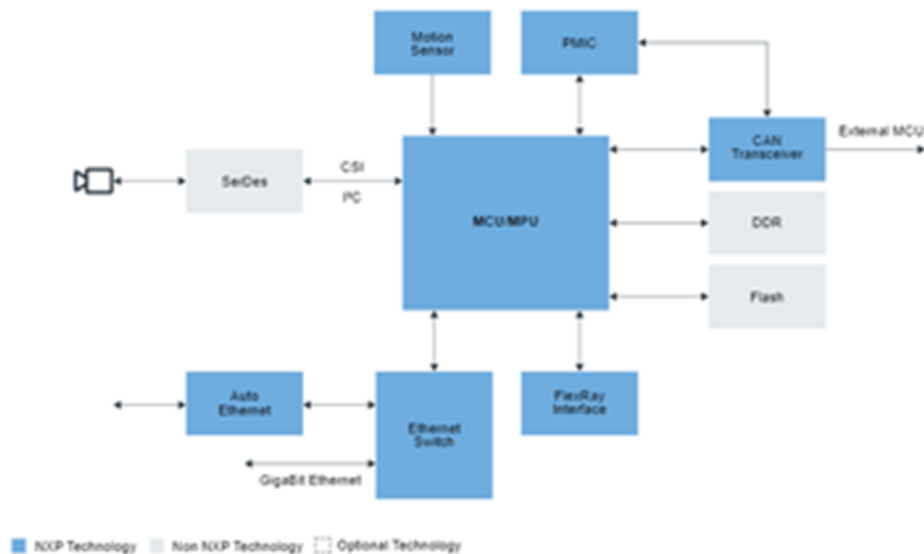

<sup>224</sup> “Driver Monitoring Systems (DMS) and Occupant Monitoring Systems,” NXP. <https://www.nxp.com/applications/automotive/adas-and-highly-automated-driving/driver-monitoring-systems-dms-and-occupant-monitoring-systems-:DRIVER-MONITORING-SYSTEMS>

## 221. Optalert

The Optalert driver monitoring system focuses on detecting drowsy or distracted driving. Optalert says their technology “is the only objective measure, capable of quantifying eye and eyelid movements. Rich data sources enable biomarkers of drowsiness to be captured, and a driver’s eyes to be tracked to accurately determine when their eyes are not on the road in front of them.”<sup>225</sup>

## 222. Pioneer

Driver monitoring system that works with Autonomous Vehicles depending on the state of the driver. In 2017, at CES, Pioneer described their Driver Monitoring System in the following:

### Driver Monitoring System

- The driver’s status must be monitored in order to determine if he or she is alert and capable of re-engaging with the vehicle and taking control of driving. Pioneer’s Driver Monitoring System is designed to detect driver conditions with image status and recognition technology used to estimate attentiveness, drowsiness, tension and fatigue.
- Facial Recognition Camera for condition and status of the driver
- Heart Rate Monitor for condition and status of the driver
- Steering Wheel Sensor
- Seat Sensor
- Seat Vibration to improve level of alertness<sup>226</sup>



The image above is from Pioneer of the technology.

### More Information

- “Pioneer Develops a Driver Monitoring System that Detects Driver Drowsiness Early and Improves the Level of Alertness,” Pioneer. December 15, 2016. <https://global.pioneer/en/corp/news/press/2016/pdf/1215-1.pdf>
- “Pioneer introduces camera for AI-based ADAS solutions,” Auto Car Pro. March 29, 2019. <https://www.autocarpro.in/news-international/pioneer-introduces-camera-for-ai-based-adas-solutions-42532>

---

<sup>225</sup> “Drowsiness & Attentiveness Algorithm,” Optalert. <https://www.optalert.com/industries/human-centric-automotive/>

<sup>226</sup> “Pioneer Showcases Automotive Technologies for Cars of Yesterday, Today, and Tomorrow,” Pioneer. <https://www.pioneerelectronics.com/PUSA/Press-Room/Car-Audio-Video/Pioneer+Showcases+Automotive+Technologies+for+Cars+of+Yesterday,+Today+and+Tomorrow>

## 223. Plessey Semiconductors

The Plessey Warden driver alertness system uses a car seat to monitor a driver. The images below are from Plessey, which says of the system:

The WARDEN™ system uses an array of sensors to detect changes in electric potential in the human body. WARDEN™ senses the electrical impulses of the heart without direct skin contact and returns an accurate R peak signal from the users ECG, this in turn can be used to calculate heart rate variance (HRV). In the end application the EPIC™ sensor electrodes can be easily and discretely incorporated inside vehicle seatbacks to access the necessary biometric signals and provide earlier warning of drowsiness or health issues than systems based on eye or head movement. WARDEN™ can be used to provide an indication of the driver's alertness, signaling to them when they need to stop and take a break. Plessey's award winning EPIC™ sensor technology has been creating considerable interest with car manufacturers as it can be used to provide low cost, reliable detection systems for several automotive applications. Using EPIC™ (Electric Potential Integrated Circuit) sensing technology, Plessey has developed WARDEN™, a new heart-rate based driver alertness monitoring system.<sup>227</sup>

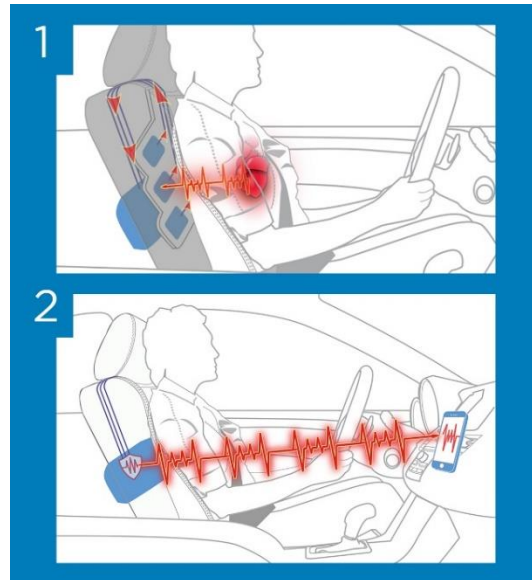

## 224. PrevictDrugs

This is an eye monitoring based mobile system for drug-impairment in Europe. The system is currently not available in-vehicles, but it shows that that eye-tracking technology is being used to detect drug impairment. Many in-vehicle driver monitoring systems track eye movements.

The PrevictDrugs system “Patients are asked to record a 10-second-long video of their eyes, using the Previct mobile application. This eye-scanning test is used to analyse eye biomarkers associated with pharmacodynamically induced pupil reactions, through a process known as pupillometry.”<sup>228</sup>

## 225. Primax

Working with company ST Microelectronics in implementing driver monitoring systems. The company produces an array of cameras, including those that measure biometrics.<sup>229</sup> According to October 18, 2019 YouTube video by ST, Primax is developing the cameras for this system.<sup>230</sup>

<sup>227</sup> “Plessey WARDEN™ driver alertness monitor,” Astute. <https://www.astute.global/products/plessey-warden-driver-alertness-monitor/>

<sup>228</sup> “A mobile application for an eye-scanning drug abuse test,” Cordis. <https://cordis.europa.eu/article/id/422074-a-mobile-application-for-an-eye-scanning-drug-abuse-test>

<sup>229</sup> “Products & Service,” Primax. [https://www.primax.com.tw/en/product\\_mobile.htm#14](https://www.primax.com.tw/en/product_mobile.htm#14)

<sup>230</sup> “VG5761: Automotive incabin module with Primax,” STmicroelectronics. YouTube. October, 18, 2019. <https://www.youtube.com/watch?v=kV2kKLbSVyo>



## 226. Seeing Machines

The company calls itself the “World leading driver monitoring technology” and its technology is in the Cadillac SuperCruise. Seeing Machines describes how DMS are critical to AV technology.

In the November 11, 2020 NHTSA RFI, Seeing Machines stated “The link between ocular metrics and intoxication is very robust.”<sup>231</sup>

Seeing Machines discusses below how their system operates:

The DMS consists of a small infrared camera and near infrared lighting pods mounted on the driver’s side vehicle cockpit and is focused toward the driver’s face. The raw video from the camera is passed to main processing element with Seeing Machines’ FOVIO Driver Monitoring Engine (DME) where it is processed real-time and measures attention by continuously searching for and tracking the features of the driver’s face and eyes. Simultaneously tracking the multiple points on the face, eyelids and pupils in a large head box over large and sudden head rotations and eye gaze angles, operating robustly in all foreseeable driving conditions including direct sunshine and total darkness, regardless of race or ethnicity, and even when the driver is wearing sunglasses is key to securing a highly reliable real-time core signal set for our classifiers for driver attention and driver state to work from.<sup>232</sup>

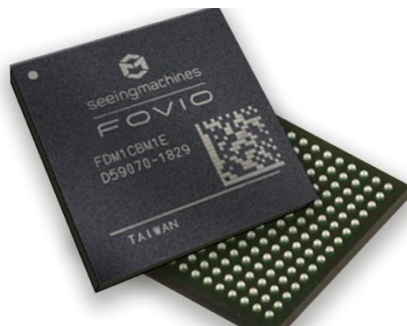

Left: Seeing Machines Fovio Chip (Seeing Machines)



Right: Cadillac SuperCruise driver monitoring system (General Motors)

<sup>231</sup> “Seeing Machines Limited: NHTSA Request for Information: Impaired Driving Technologies. Docket (NHTSA-2020-0102). January 11, 2021. [https://downloads.regulations.gov/NHTSA-2020-0102-0004/attachment\\_1.pdf](https://downloads.regulations.gov/NHTSA-2020-0102-0004/attachment_1.pdf)

<sup>232</sup> “Automotive,” Seeing Machines. <https://www.seeingmachines.com/industry-applications/automotive/>

## 227. Senseair

This is a breath-based alcohol detection system. Sense Air says of their technology development in coordination with Autoliv “our current projects include the development of a new technology to allow for contact-free, unobtrusive measurement of the driver’s breath alcohol. When measuring blood alcohol concentration, most people are familiar with breathalysers (which require drivers to provide a deep lung sample by blowing into a tube or other sensor). In contrast, the breath-based system being developed by Senseair and Autoliv Development is designed to unobtrusively analyse alcohol on the driver’s breath. Drivers will simply be able to enter the vehicle and breathe as they normally would.”<sup>233,234</sup>

### More Information

- Video of technology: <https://vimeo.com/241689018>

## 228. Senseair Patent: Combined vehicle mounted breath analyzing and hvac system and method

The 2020 Patent filed by SenseAir seems to work with the HVAC system to help passively detect alcohol impairment. The patent states “The combined HVAC and breath analyzing system 10 according to the invention provides a control unit 13 that controls both the HVAC system 12 and the breath analyzer 11 so that the settings of the HVAC system 12 is automatically selected as to speed up and/or increase the accuracy and/or reliability of the detection of alcohol or other specified substances during the time period that the breath analyzer 11 performs the BrAC measurement.”<sup>235</sup>

## 229. Speedguage Patent: Driver alertness warning system and method

The Patent filed by Speedguage in 2020 is for a driver monitoring system. The Patent states “The present disclosure is directed to systems and methods avoiding collisions by monitoring the presence and alertness of a person in a vehicle.”<sup>236</sup>

---

<sup>233</sup> “Alcohol Sensing,” Sense Air. <https://senseair.com/applications/alcohol-sensing/alcohol-sensors-in-cars/>

<sup>234</sup> “Automotive,” Sense Air. <https://senseair.com/applications/automotive/alcohol-sensors-in-cars/>

<sup>235</sup> “Combined vehicle mounted breath analyzing and hvac system and method,” Senseair. Patent WO2021002796A1. Filed July 1, 2020. <https://patents.google.com/patent/WO2021002796A1>

<sup>236</sup> “Driver alertness warning system and method,” Speedguage. Patent US20210046821A1. Filed October 30, 2020. <https://patents.google.com/patent/US20210046821A1>

## 230. Sighthound

Camera based driver monitoring system that can detect drowsy and distracted driving. The company says “Sighthound’s software uses a complex combination of monitoring functions to determine whether a driver might be distracted or tired. Alerts can be set to create a safer driving experience.”<sup>237</sup>

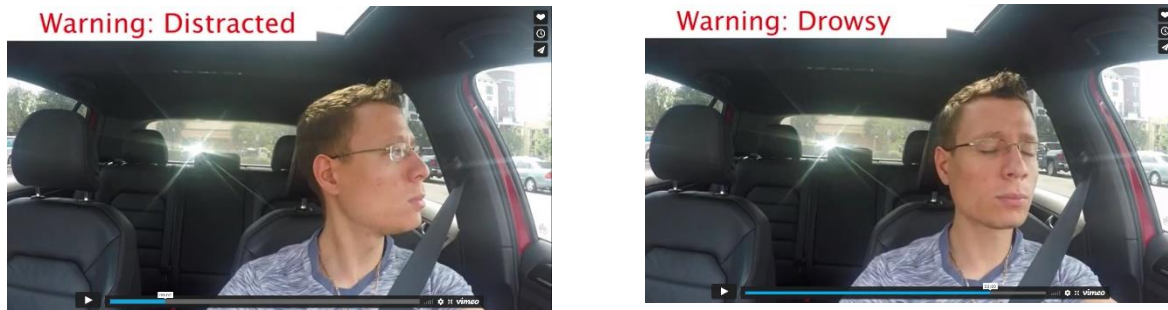

The above images are from Sighthound’s Vimeo of their driver monitoring technology.

## 231. Smart Eye

### Methods and systems

Uses sensors and software to monitor a driver via the face and voice. Smart Eye says:

Smart Eye’s DMS solution offers eye tracking software for integration in passenger cars and other vehicles to facilitate better safety and other functions that improve the user experience. By studying a person’s eye, face and head movements, Smart Eye’s interior vehicle algorithms can draw conclusions about a person’s alertness, attention and focus. Today, car manufacturers (OEM:s) that has included the technology include German premium car manufacturers as well as one of China’s largest OEM:s, Geely. Smart Eye is the market leader within the Automotive industry, paving the way for high performance reliability, precision, optimized costs and availability.<sup>238</sup>

### More Information

- Schematic of the technology: [https://smarteye.se/wp-content/uploads/2018/11/AutomotiveSolutions\\_liggande-01.svg](https://smarteye.se/wp-content/uploads/2018/11/AutomotiveSolutions_liggande-01.svg)

---

<sup>237</sup> “Automotive Solutions,” Sighthound. <https://www.sighthound.com/solutions/automotive>

<sup>238</sup> “Driver Monitoring System | Interior Sensing for vehicle integration,” Smart Eye. <https://smarteye.se/automotive-solutions/>

## 232. Sober Steering Sensors Canada Patent: System and method for detecting and measuring ethyl alcohol in the blood of a motorized vehicle driver transdermally

FIG. 4

The system is for a Patent for a steering wheel touch-based alcohol sensor.<sup>239</sup>

The sketch to the right is from the Patent of the steering wheel sensors for alcohol.

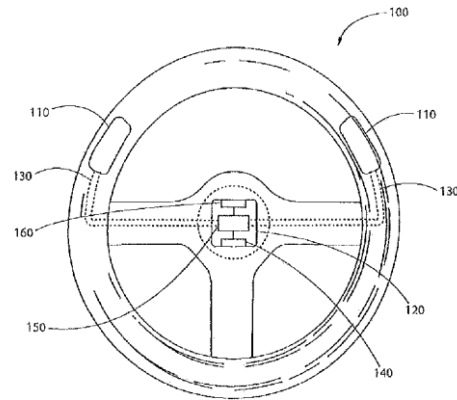

## 233. SRI

The system is for driver monitoring and "incorporates a suite of infrared and 3D cameras to track driver's eye movements, facial expressions, and skeletal positioning from which it gauges body language. It then strives to identify drowsiness or even potentially dangerous emotional states, like anxiety or boredom, which could affect driving. To counteract these states, the vehicle might blast the air conditioning to help a driver stay alert or maybe suggest an alternate less traffic-choked or boring route if it perceives irritability or boredom. The more miles each driver spends in the car, the more accurately the artificial intelligence recognizes and responds to the driver's needs."<sup>240</sup>

<sup>239</sup> "System and method for detecting and measuring ethyl alcohol in the blood of a motorized vehicle driver transdermally and non-invasively in the presence of interferences," Sober Steering Sensors of Canada. Patent US9326713B2. Filed August 3, 2012. <https://patents.google.com/patent/US9326713B2>

<sup>240</sup> "My Doctor the Car? Future Cars Might Monitor Drivers' Health and Wellbeing," Motortrend. January 15, 2021. <https://www.motortrend.com/news/driver-health-wellbeing-monitor-car-tech-ces/>

## 234. ST Microelectronics

The technology is a camera based solution to driver monitoring. ST Microelectronics states:

ST comes with a scalable solution for Driver Monitoring System (DMS) applications, thanks to its HDR Global Shutter sensor (1.6 Mpixel & 2.3 Mpixel), together with a Multichannel Voltage regulator ASIL-D compliant and Automotive led drivers, MEMS Sensors, assuring the best flexibility for high-end computer vision applications in very critical environments.<sup>241</sup>

The image below is schematic of the driver monitoring system from ST Microelectronics.

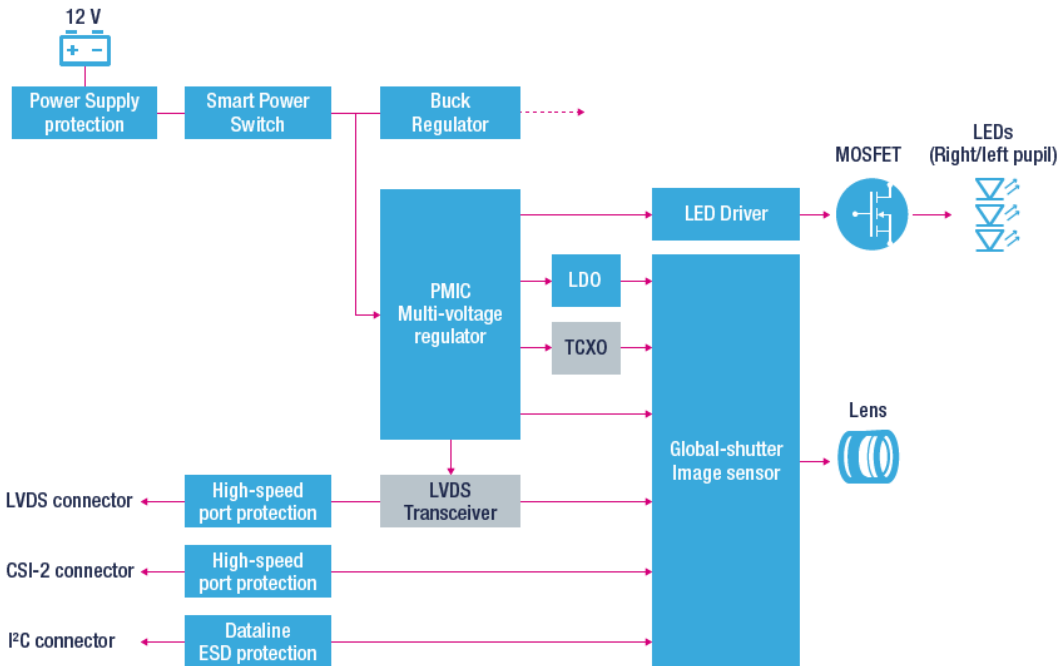

## 235. Tata Elxsi

The product provides software and hardware for driver monitoring systems.<sup>242,243</sup>

## 236. TruTouch

This is a touch based alcohol sensor that has been in development since at least 2012.<sup>244</sup>

<sup>241</sup> "Driver Monitoring Systems," ST. <https://www.st.com/en/applications/adas/driver-monitoring-system-dms.html>

<sup>242</sup> "Driving Behaviour Monitoring System," Tata Elxsi.

<https://tataelxsi.com/storage/insights/March2021/H9IKxw4HvQAaQRsf6iV8.pdf>

<sup>243</sup> "ADAS & Autonomous Driving," Tata Elxsi. <https://www.tataelxsi.com/industries/automotive/c-a-s-e/autonomous-driving-and-adas>

<sup>244</sup> "TruTouch 2500 is a non-invasive sensor that quickly and accurately measures alcohol intoxication, and also has the option to simultaneously verify user identity using light through the skin," TruTouch. Business Wire. October 9,

## 237. Thunder Power Patent: Method for recognizing vehicle driver and determining whether driver can start vehicle

The 2016 Patent is for a touch-alcohol sensor on a steering wheel, other sensors, that includes other technology to determine the identity of the driver.<sup>245</sup>

## 238. Veoneer

Eye and head based monitoring system that measures driver's attention and fatigue. The company says:

Veoneer's state-of-the-art driver monitoring system (DMS) can detect distracted and drowsy drivers by accurately measuring eye and head position, driver attention and fatigue. The DMS will invoke action when a dangerous situation is detected or imminent. A reliable analysis of the driver's state will also enable Veoneer to develop technologies that are critical for supporting highly autonomous driving functions, with safe hands-off-wheel operation. Veoneer's DMS understands driver behavior, allowing tomorrow's vehicles to make better decisions to improve comfort and safety.

Driver monitoring is rapidly spreading across vehicle manufacturers who are launching level 3 and level 4 autonomous driving systems. Veoneer's solution builds on traditional systems and adds face identification, expression recognition for human-machine interactive systems, which enhances driver/vehicle trust and allows tomorrow's vehicles to make better decisions to improve comfort and safety.<sup>246</sup>

### More Information

- Video of technology: <https://youtu.be/LGAUYA3Y4Ms>

## 239. Wipro

The camera-based monitoring system measures a person's head and eye as well as check their level of attentiveness. Wipro says:

Wipro's Driver Monitoring System is a smart dash camera-based solution to recognize drivers and monitor their behavior to check for the level of attentiveness. The state-of-the-art solution leverages computer vision to continuously monitor drivers and passengers, by measuring eye and head position, presence of distractions within the cabin etc. The system makes smart situational decisions to avert disaster in case of drowsiness, distraction, fatigue, or even drunk driving.<sup>247</sup>

---

2012. <https://www.businesswire.com/news/home/20121009006026/en/TruTouch-Technologies-Announces-Next-Generation-Alcohol-Intoxication-Detection-System-to-Counter-220-Billion-Annual-Costs>

<sup>245</sup> "Method for recognizing vehicle driver and determining whether driver can start vehicle," Thunder Power. Patent US10173687B2. Filed March 7, 2016. <https://patents.google.com/patent/US10173687B2>

<sup>246</sup> "Driving Monitoring Systems," Veoneer. <https://www.veoneer.com/en/driver-monitoring-systems>

<sup>247</sup> "Driver Monitoring Systems," Wipro. <https://www.wipro.com/engineeringNXT/driver-monitoring-system/>

## 240. Xander Kardian

The driver monitoring system tracks heart rates, respiratory rates and the entire cabin. The technology “by using impulse-radio ultra-wideband (IR-UWB) radar technology it can monitor the driver's general health, notice drops in resting heart rate or respiration that could indicate drowsiness—information that could be used to turn up the air conditioning or music to rouse the driver. Then, at the end of a journey, it can definitively detect the presence of a living being in the back seat, triggering a mobile-phone alert for the driver. Xandar Kardian claims that its single sensor is more cost-effective than the seven- or eight-seat sensors typically required to serve a cabin monitoring system.”<sup>248</sup>

### More Information

- Video of technology: <https://www.youtube.com/watch?v=GZDFCTI9NJ0>

## 241. Xperi

Helps with the development of algorithms for driver monitoring systems. Xperi describes their technology:

Our in-cabin monitoring technologies support a safer driving experience and may ultimately help prevent traffic accidents, by providing driver and occupant state analytics through edge computing and sophisticated neural networks. In addition to detecting all human occupants of a vehicle, our solution detects pets and relevant objects, such as child seats. For each human occupant, the technology provides advanced analytics such as passenger authentication, age group, emotional state, and body pose.

Xperi enables OEMs to deliver high-performing, camera-based in-cabin monitoring algorithms in their vehicles. Significantly, our solutions are able to monitor drivers with multiple occlusion types, including: glasses, helmets, hats, scarves, and face masks. Occlusion handling has become a particularly valuable feature today as so many people around the world are wearing face masks as a preventative measure against COVID-19.<sup>249</sup>

The image on the right is of the technology from Xperi.

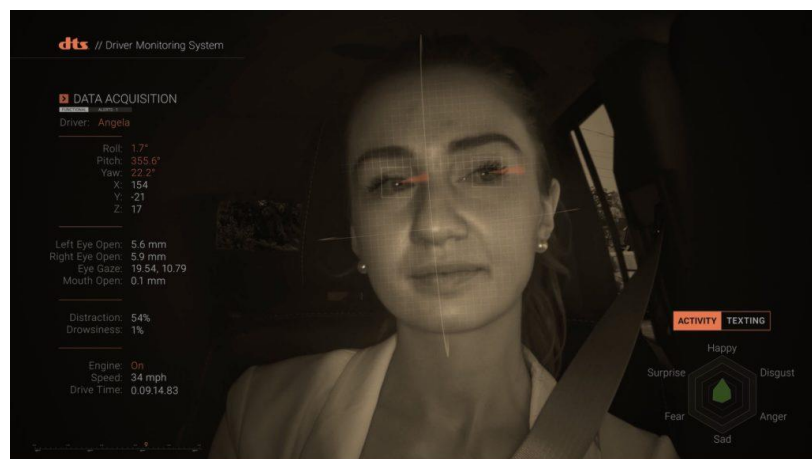

<sup>248</sup> “My Doctor the Car? Future Cars Might Monitor Drivers' Health and Wellbeing,” Motortrend.

<sup>249</sup> “Xperi wins key OEM vehicle design-ins for in-cabin monitoring system,” Xperi. May 6, 2020.

<https://www.xperi.com/news/xperi-wins-key-oem-vehicle-design-ins-for-in-cabin-monitoring-systems/>