

## **VIN marking area for Sorento Plug-in Hybrid model**

---

---

- 1. Hood**
- 2. Tail gate**
- 3. Front Fender (LH/RH)**
- 4. Front Door (LH/RH)**
- 5. Rear Door (LH/RH)**
- 6. Side Outer Panel (LH/RH)**
- 7. Front Bumper**
- 8. Rear Bumper**
- 9. Engine**
- 10. Transmission [AT only]**



# Hood

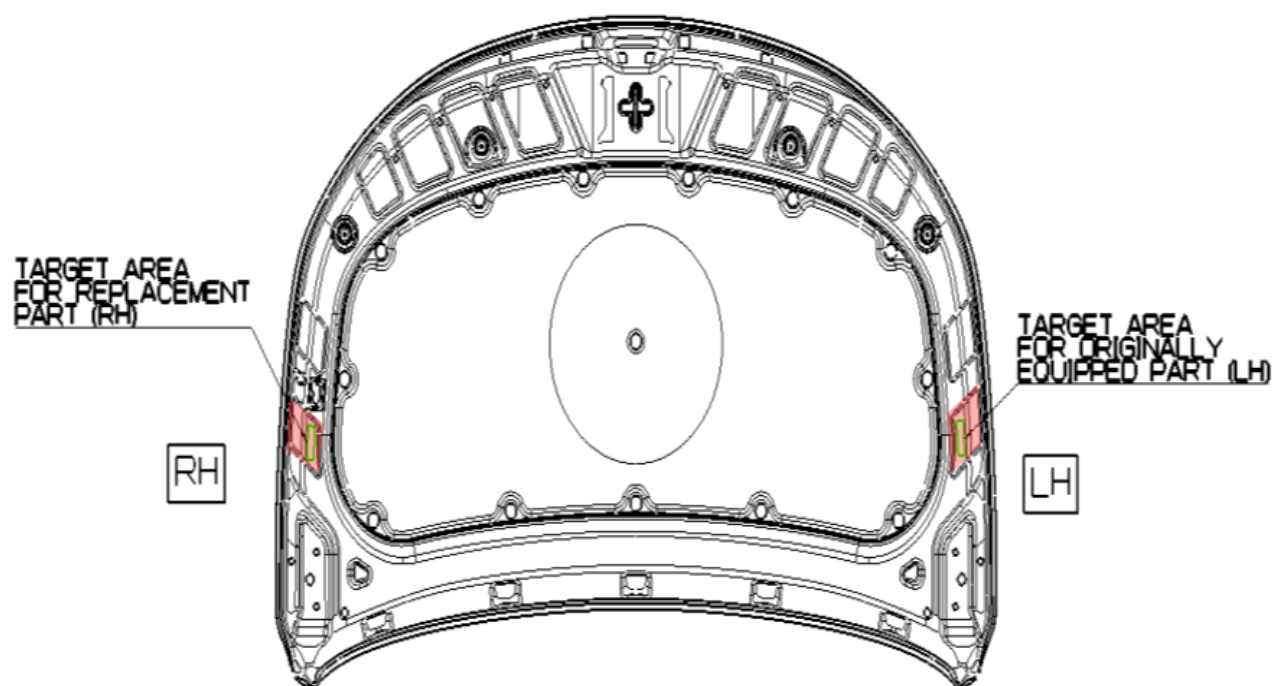

# Tailgate

TARGET AREA  
FOR REPLACEMENT  
PART (LH)

TARGET AREA  
FOR ORIGINALLY  
EQUIPPED PART (RH)

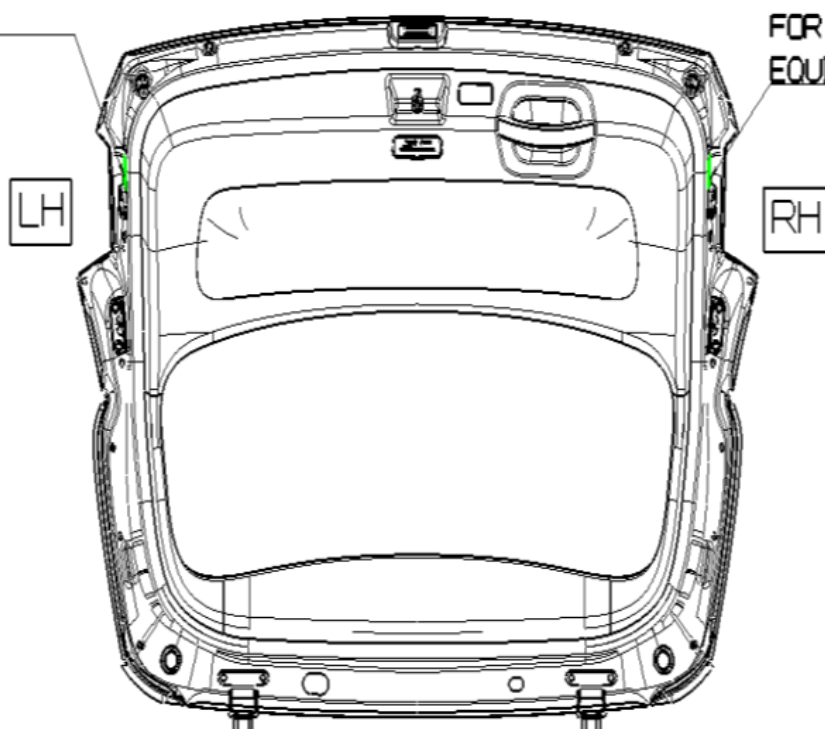

# Front Fender (LH/RH)

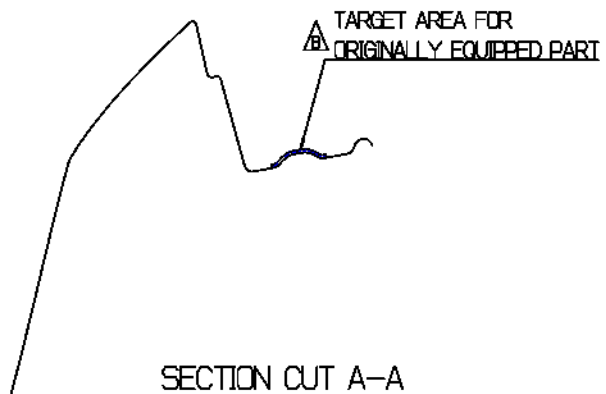
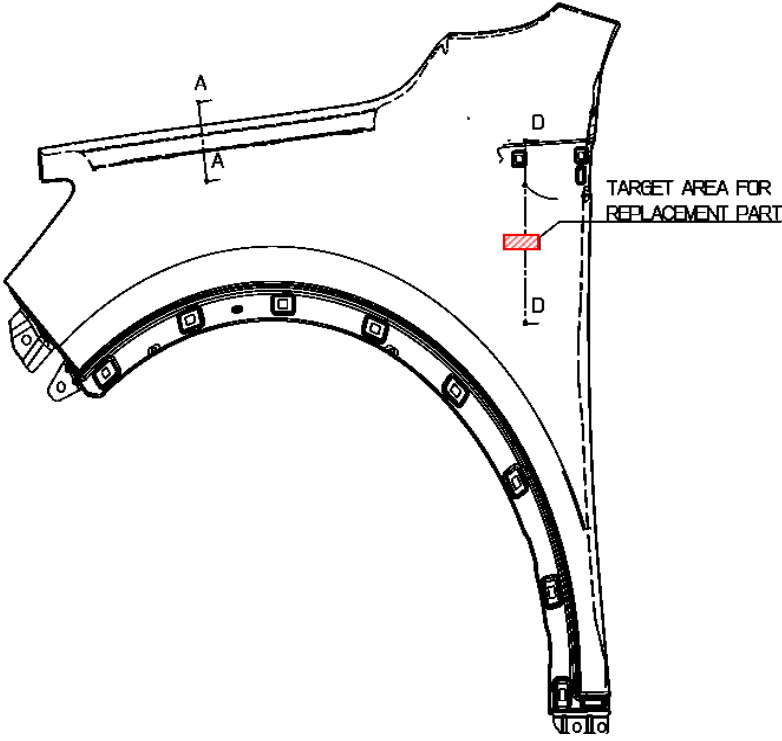

# Front Door (LH/RH)

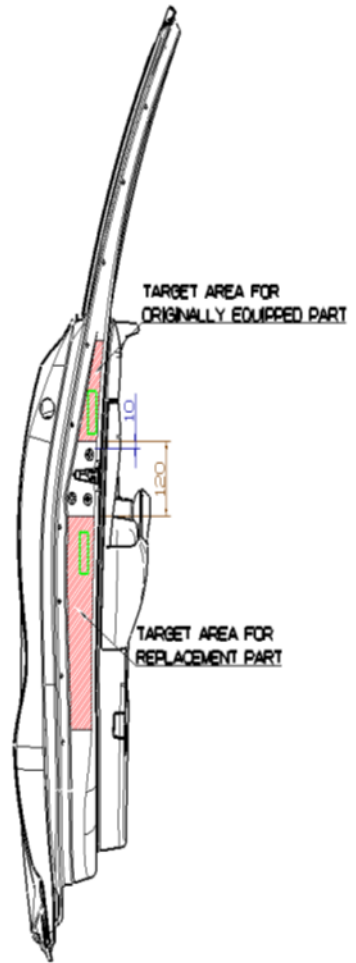
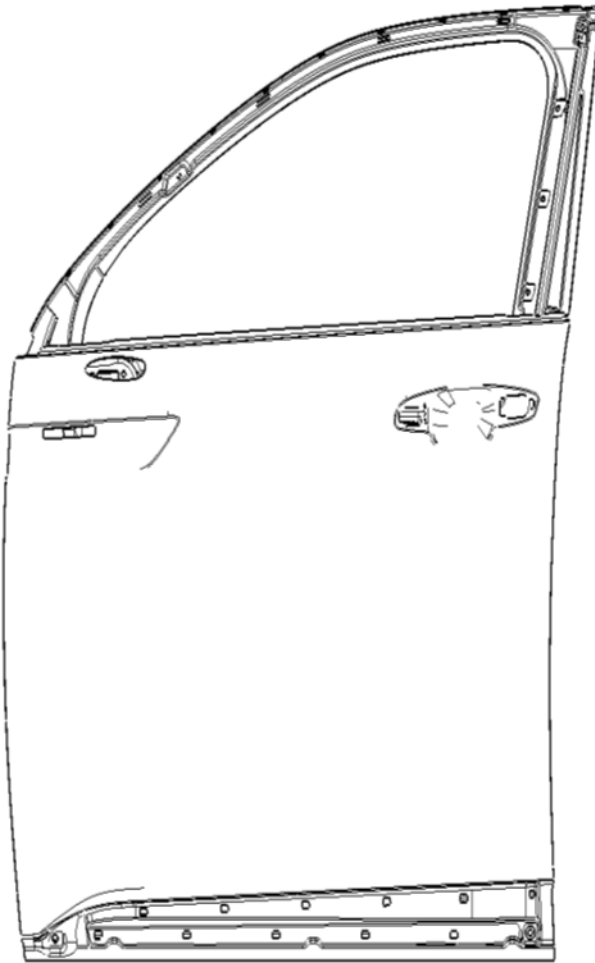

VIEW W

# Rear Door (LH/RH)

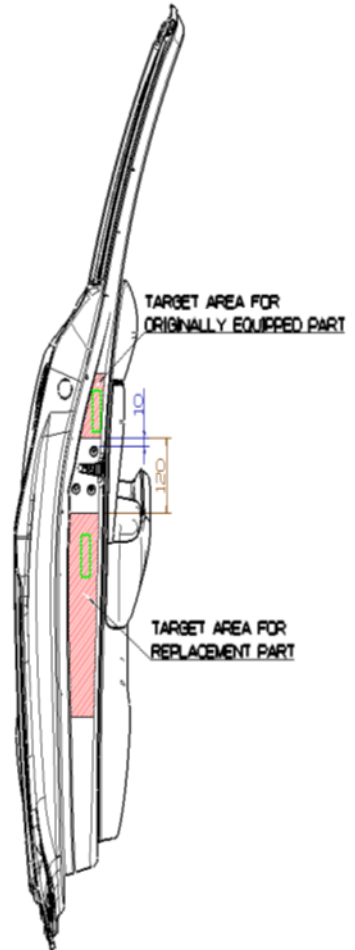
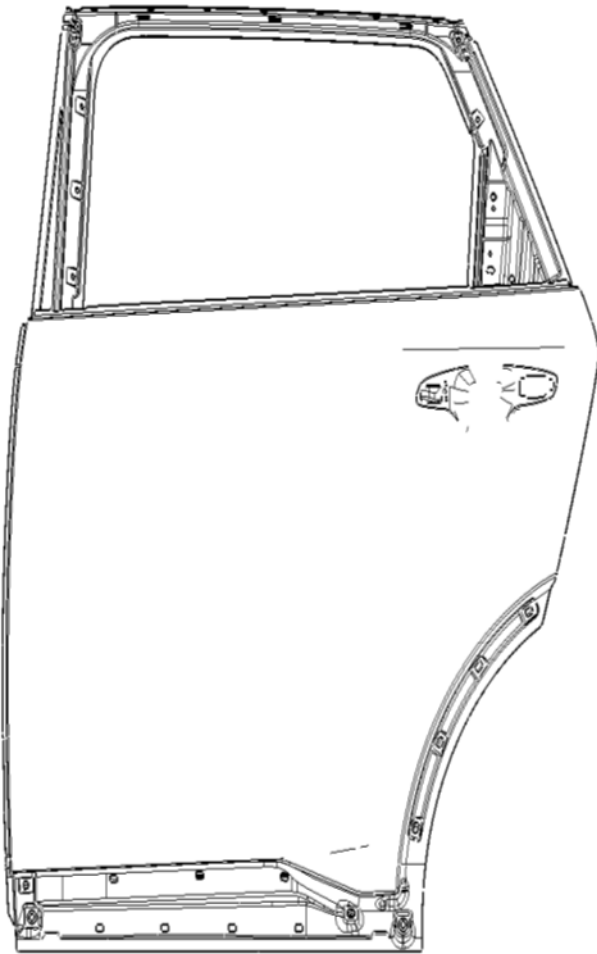

VIEW V

# Side Outer Panel (LH/RH)

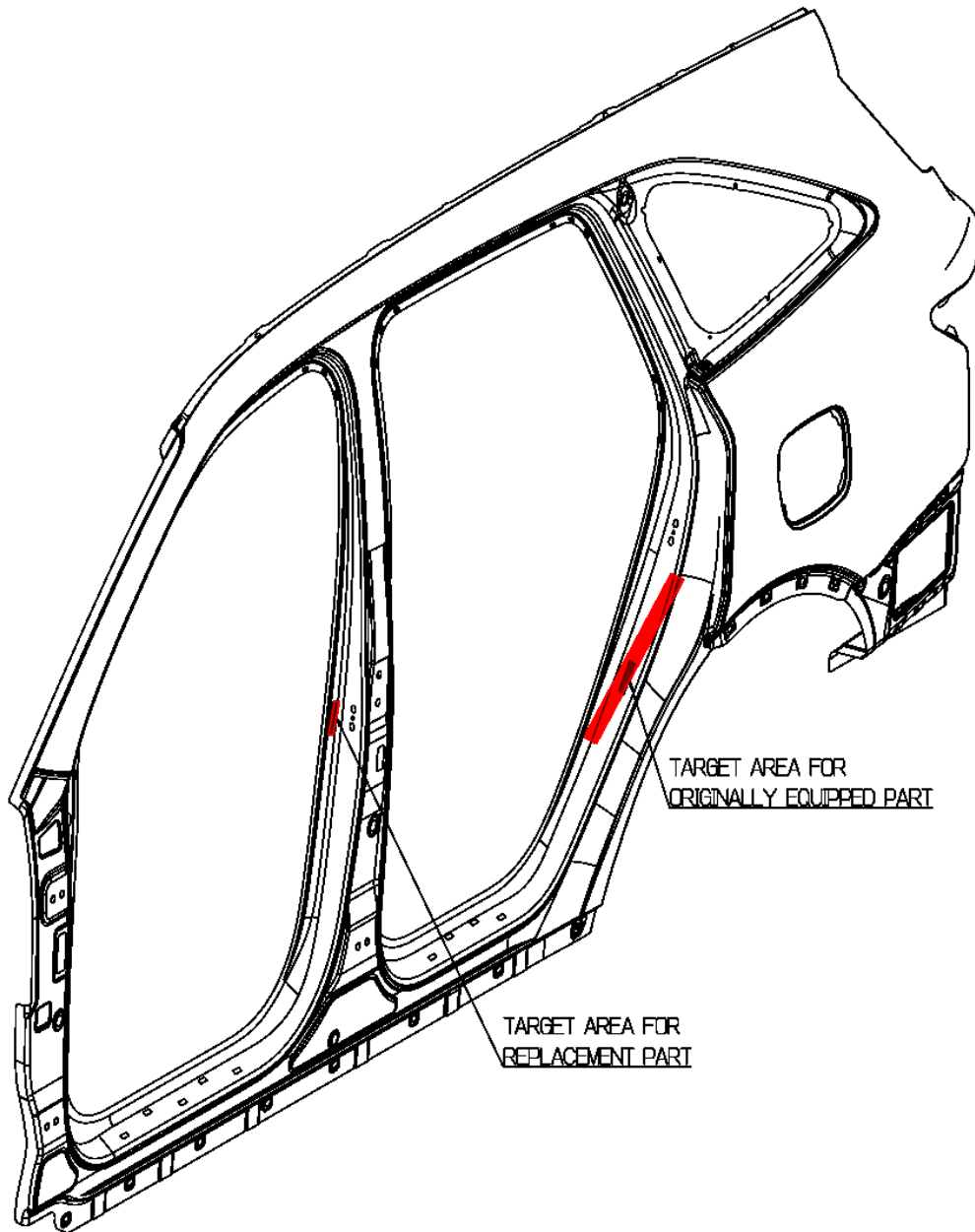

## Front Bumper

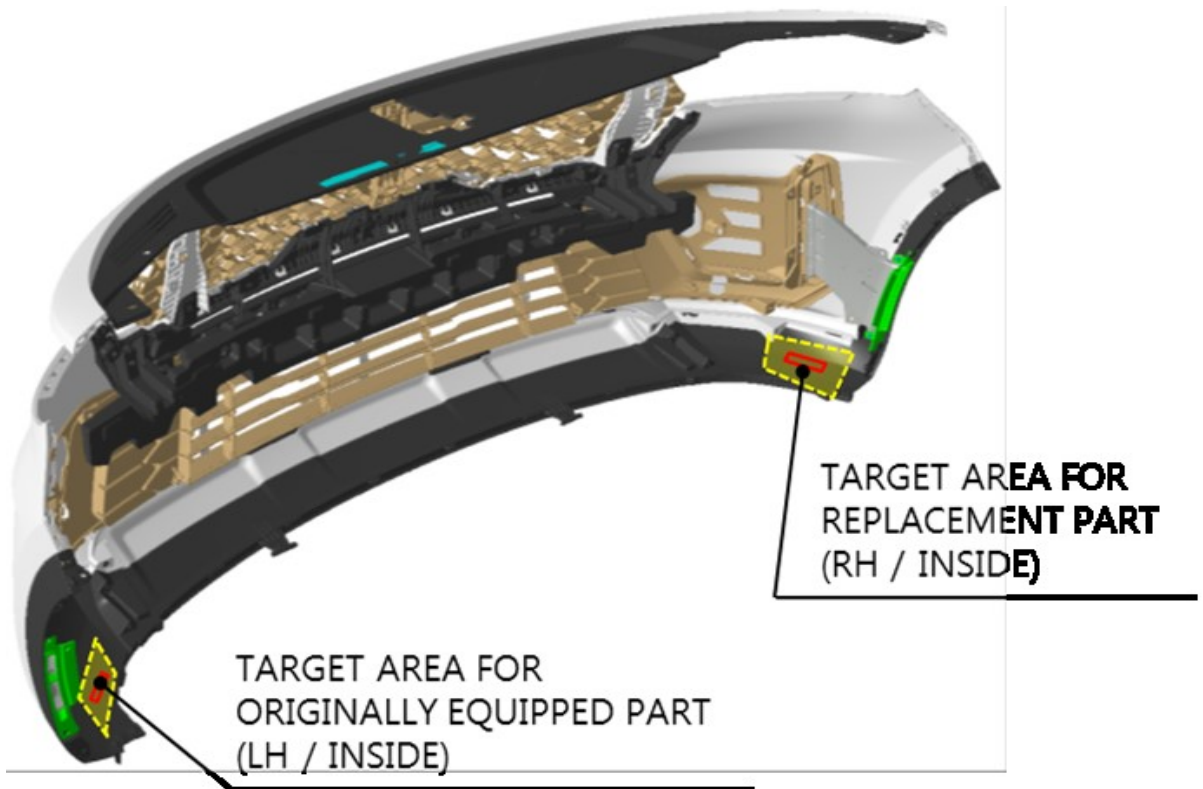



# Rear Bumper

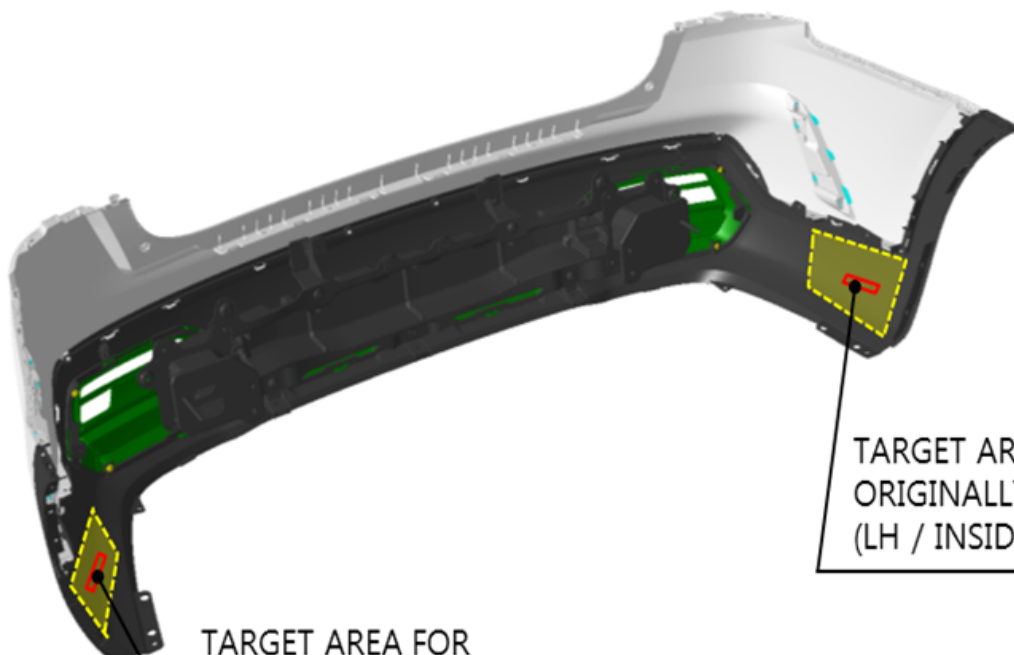

TARGET AREA FOR  
**REPLACEMENT PART**  
(RH / INSIDE)

TARGET AREA FOR  
**ORIGINALLY EQUIPPED PART**  
(LH / INSIDE)

# Engine (1.6 T-GDI PHEV)

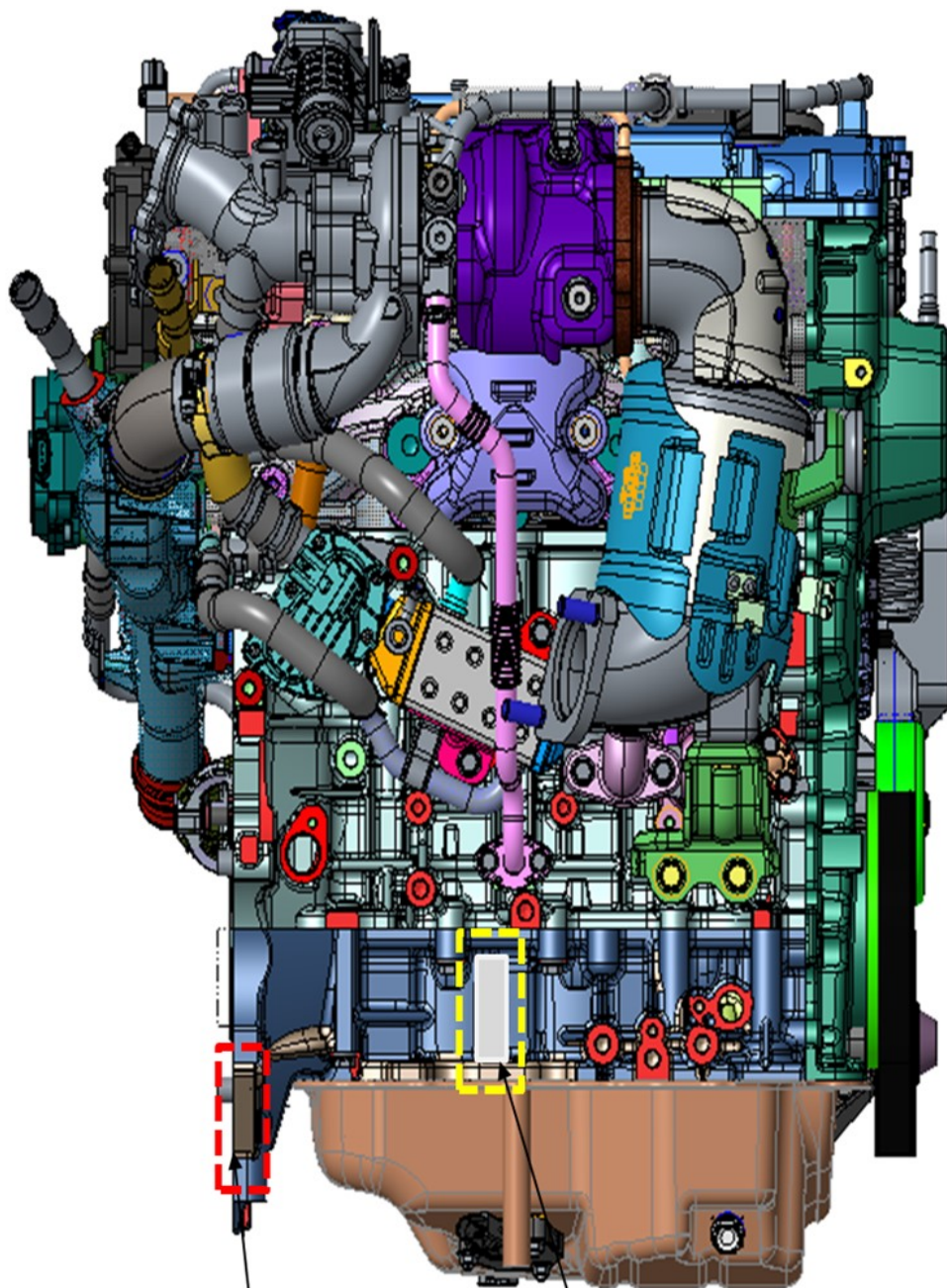

**TARGET AREA FOR  
REPLACEMENT PART**

**TARGET AREA FOR  
ORIGINALLY EQUIPPED PART**

# Transmission (Automatic)

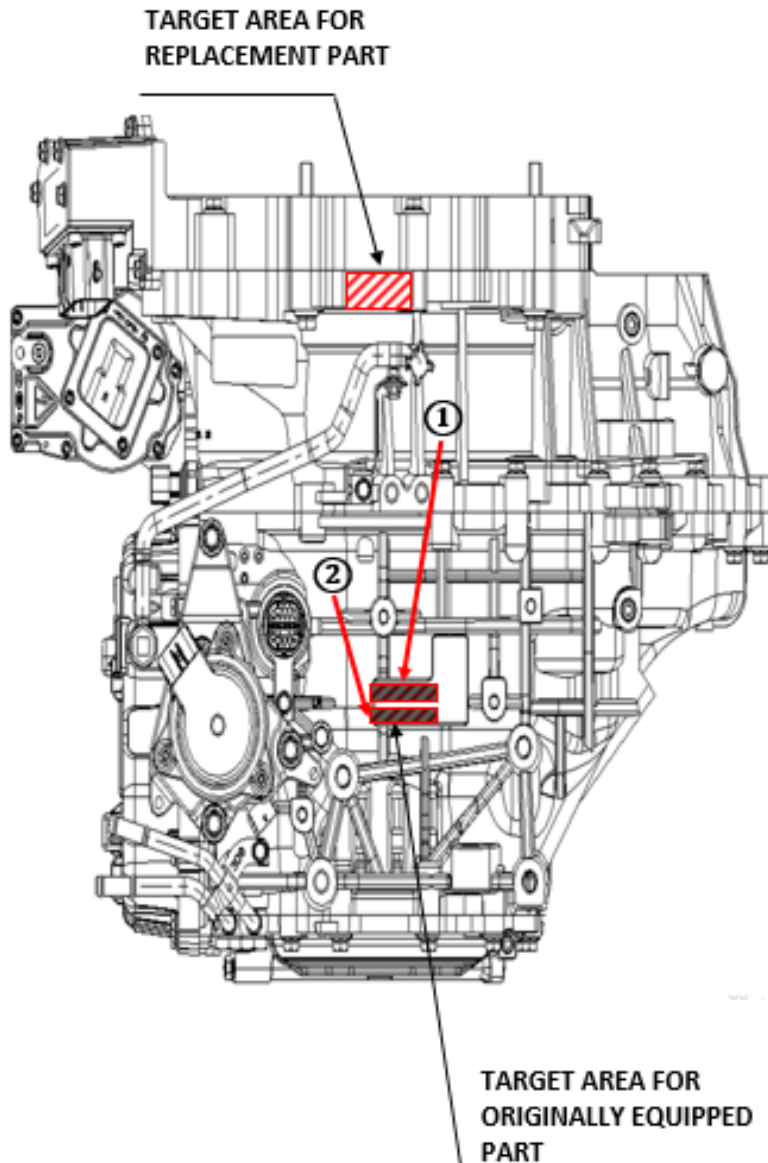

※ VIN plate for originally equipped part  
will be attached to either ① or ②.