

**NEW CAR ASSESSMENT PROGRAM
LANE DEPARTURE WARNING CONFIRMATION TEST
NCAP-DRI-LDW-21-11**

2021 Toyota Camry SE Sedan

DYNAMIC RESEARCH, INC.

355 Van Ness Avenue, STE 200
Torrance, California 90501



16 March 2021

Final Report

Prepared Under Contract No. DTNH22-14-D-00333

**U.S. DEPARTMENT OF TRANSPORTATION
National Highway Traffic Safety Administration
New Car Assessment Program
1200 New Jersey Avenue, SE
West Building, 4th Floor (NRM-110)
Washington, DC 20590**

Prepared for the Department of Transportation, National Highway Traffic Safety Administration, under Contract No. DTNH22-14-D-00333.

This publication is distributed by the U.S. Department of Transportation, National Highway Traffic Safety Administration, in the interest of information exchange. The opinions, findings, and conclusions expressed in this publication are those of the author(s) and not necessarily those of the Department of Transportation or the National Highway Traffic Safety Administration. The United States Government assumes no liability for its contents or use thereof. If trade or manufacturer's names or products are mentioned, it is only because they are considered essential to the object of the publication and should not be construed as an endorsement. The United States Government does not endorse products of manufacturers.

Prepared By: J. Lenkeit and J. Partridge

Program Manager

Test Engineer

Date: 16 March 2021

1. Report No. NCAP-DRI-LDW-21-11	2. Government Accession No.	3. Recipient's Catalog No.	
4. Title and Subtitle Final Report of Lane Departure Warning Confirmation Test of a 2021 Toyota Camry SE Sedan.		5. Report Date 16 March 2021	
		6. Performing Organization Code DRI	
7. Author(s) J. Lenkeit, Program Manager J. Partridge, Test Engineer		8. Performing Organization Report No. DRI-TM-20-185	
9. Performing Organization Name and Address Dynamic Research, Inc. 355 Van Ness Ave, STE 200 Torrance, CA 90501		10. Work Unit No.	
		11. Contract or Grant No. DTNH22-14-D-00333	
12. Sponsoring Agency Name and Address U.S. Department of Transportation National Highway Traffic Safety Administration New Car Assessment Program 1200 New Jersey Avenue, SE, West Building, 4th Floor (NRM-110) Washington, DC 20590		13. Type of Report and Period Covered Final Test Report February - March 2021	
		14. Sponsoring Agency Code NRM-110	
15. Supplementary Notes			
16. Abstract These tests were conducted on the subject 2021 Toyota Camry SE Sedan in accordance with the specifications of the New Car Assessment Program's (NCAP) most current Test Procedure in docket NHTSA-2006-26555-0135 to confirm the performance of a Lane Departure Warning system. The vehicle passed the requirements of the test for all three lane marking types and for both directions.			
17. Key Words Lane Departure Warning, LDW, New Car Assessment Program, NCAP		18. Distribution Statement Copies of this report are available from the following: NHTSA Technical Reference Division National Highway Traffic Safety Administration 1200 New Jersey Avenue, SE Washington, DC 20590	
19. Security Classif. (of this report) Unclassified	20. Security Classif. (of this page) Unclassified	21. No. of Pages 165	22. Price

TABLE OF CONTENTS

<u>SECTION</u>	<u>PAGE</u>
I. INTRODUCTION	1
II. DATA SHEETS	2
Data Sheet 1: Test Results Summary	3
Data Sheet 2: Vehicle Data	4
Data Sheet 3: Test Conditions	5
Data Sheet 4: Lane Departure Warning System Operation	7
III. TEST PROCEDURES	10
A. Test Procedure Overview	10
B. Lane Delineation Markings	11
C. Test Validity	13
D. Pass/Fail Criteria	14
E. Instrumentation	14
APPENDIX A Photographs	A-1
APPENDIX B Excerpts from Owner's Manual	B-1
APPENDIX C Run Log	C-1
APPENDIX D Time Histories	D-1

Section I

INTRODUCTION

The purpose of the testing reported herein was to confirm the performance of a Lane Departure Warning (LDW) system installed on a 2021 Toyota Camry SE Sedan. The LDW system for this vehicle provides both visual and auditory alerts. The vehicle passed the requirements of the test for all three lane marking types and for both directions.

The test procedure is described in detail in the National Highway Traffic Safety Administration (NHTSA) document "LANE DEPARTURE WARNING SYSTEM CONFIRMATION TEST" dated February of 2013 (Docket No. NHTSA-2006-26555-0135). Its purpose is to confirm the performance of LDW systems installed on light vehicles with gross vehicle weight ratings (GVWR) of up to 10,000 lbs. Current LDW technology relies on sensors to recognize a lane delimiting edge line. As such, the test procedures described in the document rely on painted lines, taped lines, or Botts Dots being present on the test course to emulate those found on public roadways. Although it is impossible to predict what technologies could be used by future LDW systems (e.g., magnetic markers, RADAR reflective striping, ultra violet paint, infrared, etc.), it is believed that minor modifications to these procedures, when deemed appropriate, could be used to accommodate the evaluation of alternative or more advanced LDW systems.

Section II
DATA SHEETS

LANE DEPARTURE WARNING
DATA SHEET 1: TEST RESULTS SUMMARY

(Page 1 of 1)

2021 Toyota Camry SE Sedan

VIN: 4T1T11AK4MU52xxxx

Test Date: 2/22/2021

Lane Departure Warning setting: LTA - On

Sensitivity - High

Test 1 – Continuous White Line Left: Pass Right: Pass

Test 2 – Dashed Yellow Line Left: Pass Right: Pass

Test 3 – Botts Dots Left: Pass Right: Pass

Overall: Pass

Notes:

LANE DEPARTURE WARNING
DATA SHEET 2: VEHICLE DATA

(Page 1 of 1)

2021 Toyota Camry SE Sedan

TEST VEHICLE INFORMATION

VIN: 4T1T11AK4MU52xxxx

Body Style: Sedan

Color: Super White/EA20

Date Received: 2/15/2021

Odometer Reading: 4 mi

DATA FROM VEHICLE'S CERTIFICATON LABEL

Vehicle manufactured by: TOYOTA MOTOR MANUFACTURING,
KENTUCKY, INC.

Date of manufacture: 11/20

Vehicle Type: PASS. CAR

DATA FROM TIRE PLACARD

Tires size as stated on Tire Placard: Front: 235/45R18

Rear: 235/45R18

Recommended cold tire pressure: Front: 240 kPa (35 psi)

Rear: 240 kPa (35 psi)

TIRES

Tire manufacturer and model: Bridgestone Turanza EL440

Front tire size: 235/45R18 94V

Rear tire size: 235/45R18 94V

Front tire DOT prefix: 7XFU JB2

Rear tire DOT prefix: 7XFU JB2

LANE DEPARTURE WARNING
DATA SHEET 3: TEST CONDITIONS

(Page 1 of 2)

2021 Toyota Camry SE Sedan

GENERAL INFORMATION

Test date: 2/22/2021

AMBIENT CONDITIONS

Air temperature: 21.1 C (70 F)

Wind speed: 4.1 m/s (9.2 mph)

- X Wind speed ≤ 10 m/s (22 mph)
- X Tests were not performed during periods of inclement weather. This includes, but is not limited to, rain, snow, hail, fog, smoke, or ash.
- X Tests were conducted during daylight hours with good atmospheric visibility (defined as an absence of fog and the ability to see clearly for more than 5000 meters). The tests were not conducted with the vehicle oriented into the sun during very low sun angle conditions, where the sun is oriented 15 degrees or less from horizontal, and camera "washout" or system inoperability results.

VEHICLE PREPARATION

Verify the following:

All non-consumable fluids at 100% capacity: X

Fuel tank is full: X

Tire pressures are set to manufacturer's recommended cold tire pressure: X

Front: 240 kPa (35 psi)

Rear: 240 kPa (35 psi)

LANE DEPARTURE WARNING
DATA SHEET 3: TEST CONDITIONS

(Page 2 of 2)

2021 Toyota Camry SE Sedan

WEIGHT

Weight of vehicle as tested including driver and instrumentation

Left Front: 507.6 kg (1119 lb)

Right Front: 484.0 kg (1067 lb)

Left Rear: 353.3 kg (779 lb)

Right Rear: 332.9 kg (734 lb)

Total: 1677.8 kg (3699 lb)

LANE DEPARTURE WARNING
DATA SHEET 4: LANE DEPARTURE WARNING SYSTEM OPERATION

(Page 1 of 3)

2021 Toyota Camry SE Sedan

Name of the LDW option, option package, etc.:

Toyota Safety Sense 2.5 +, standard equipment

The LDW function is called Lane Tracking Assist (LTA).

Type and location of sensor(s) used:

The system uses a mono-camera located in the upper center windshield.

Lane Departure Warning Setting used in test:

LTA - On

Sensitivity - High

How is the Lane Departure Warning presented to the driver?
(Check all that apply)

<input checked="" type="checkbox"/>	Warning light
<input checked="" type="checkbox"/>	Buzzer or auditory alarm
<input type="checkbox"/>	Vibration
<input type="checkbox"/>	Other _____

LANE DEPARTURE WARNING

DATA SHEET 4: LANE DEPARTURE WARNING SYSTEM OPERATION

(Page 2 of 3)

2021 Toyota Camry SE Sedan

Describe the method by which the driver is alerted. For example, if the warning is a light, where is it located, its color, size, words or symbol, does it flash on and off, etc. If it is a sound, describe if it is a constant beep or a repeated beep. If it is a vibration, describe where it is felt (e.g., pedals, steering wheel), the dominant frequency, (and possibly magnitude), the type of warning (light, auditory, vibration, or combination), etc.

The driver is alerted with a series of auditory beeps centered at 1560 Hz and a small orange lane departure symbol located in the lower right portion of the center IP which flashes on and off.

See Appendix A, Figure A11.

Is the vehicle equipped with a switch whose purpose is to render LDW inoperable? X Yes
_____ No

If yes, please provide a full description including the switch location and method of operation, any associated instrument panel indicator, etc.

There is a button on the right side of the steering wheel with a lane departure symbol that deactivates the LDW system. When the LDW system is deactivated, the lane departure symbol in the lower right portion of the center IP is no longer present.

See Appendix A, Figure A12.

Is the vehicle equipped with a control whose purpose is to adjust the range setting or otherwise influence the operation of LDW? X Yes
_____ No

LANE DEPARTURE WARNING
DATA SHEET 4: LANE DEPARTURE WARNING SYSTEM OPERATION

(Page 3 of 3)

2021 Toyota Camry SE Sedan

If yes, please provide a full description.

The sensitivity can be adjusted using buttons on the left side of the steering wheel to interact with system menus displayed in the center of the instrument cluster. The hierarchy is:

Return arrow button

Settings ("Gear" Symbol)

LTA

Sensitivity: repeated pushes of the center button will change the sensitivity setting.

See Appendix A, Figures A9 and A10.

Are there other driving modes or conditions that Yes
render LDW inoperable or reduce its effectiveness? No

If yes, please provide a full description.

Limitations of the system are described on pages 275 - 278 of the Owner's Manual, shown in Appendix B, pages B-19 through B-22.

Notes:

Section III

TEST PROCEDURES

A. Test Procedure Overview

Each LDW test involved one of three lane marking types: solid white lines, dashed yellow lines, or Botts Dots. Lane departures were done both to the left and to the right, and each test condition was repeated five times, as shown in Table 1.

Table 1. LDW Test Matrix

Lane Geometry	Line Type	Departure Direction	Number of Trials
Straight	Solid	L	5
		R	5
	Dashed	L	5
		R	5
	Botts Dots	L	5
		R	5

Prior to the start of a test series involving a given lane marking type and departure direction combination, the accuracy of the distance to lane marking measurement was verified. This was accomplished by driving the vehicle to the approximate location at which the lane departure would occur and placing the tire at the lane marking edge of interest (i.e., distance to lane marking = 0). The real-time display of distance to the lane marking was then observed to verify that the measured distance was within the tolerance (5 cm). If the measured distance was found to be greater than the tolerance, the instrumentation setup was checked and corrected, if necessary. If the measured distance was found to be within the tolerance, the instrumentation setup was considered appropriate and the test series was begun.

To begin the maneuver, the vehicle was accelerated from rest to a test speed of 72.4 km/h (45 mph), while being driven in a straight line parallel to the lane marking of interest, with the centerline of the vehicle approximately 1.83 m (6.0 ft) from the lane edge (i.e., such that the vehicle would pass through the center of the start gate). The test speed was achieved at least 60 m (200 ft) before the start gate was reached. Striking any start gate cones was not permitted, and any run in which a cone was struck was considered to be invalid. Also, during the initialization and test phases, the test driver avoided using turn signals and avoided applying any sudden acceleration, sudden steering, or sudden braking, and any use of the turn signals, sudden acceleration, sudden steering, or sudden braking invalidated the test trial.

Data collection began with the vehicle at least 60 m (200 ft) from the start gate, which was configured using a pair of non-reflective, low-contrast color traffic cones. A second set of cones, placed 6 m (20 ft) longitudinally before the start gate, was used to guide the driver into the start gate. The lateral width between the cone pairs was 20 cm (8 in) greater than the width of the vehicle, and the centerline of each pair was laterally offset from the lane marking by 1.8 m (6 ft).

Once the driver passed the gate, the driver manually input sufficient steering to achieve a lane departure with a target lateral velocity of 0.5 m/s with respect to the lane line. As shown in Figure 1, two additional non-reflective cones were used to guide the driver in making this steering maneuver. Throughout the maneuver, the driver modulated the throttle or used cruise control, as appropriate, such that vehicle speed remained at constant speed. The test was considered complete when the vehicle crossed at least 1 m (3.3 ft) over the lane edge boundary.

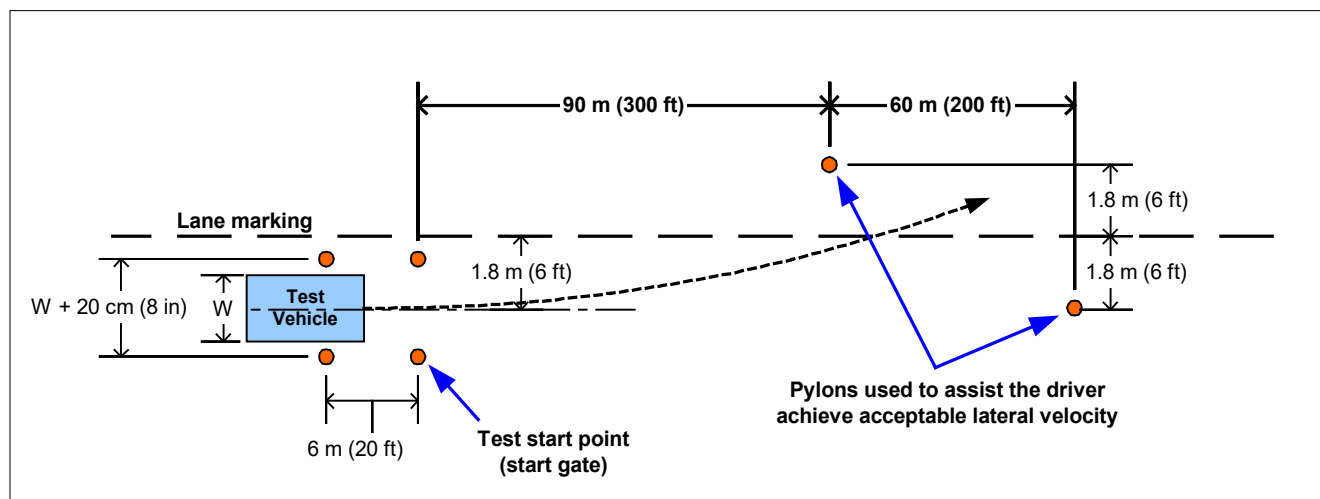

Figure 1. Position of Cones Used to Assist Driver

Data collected included vehicle speed, position, and yaw rate. In addition to cone strikes, vehicle speed and yaw rate data were used to identify invalid runs as described in Section C below. Data from trials where speed or yaw rate were outside of the performance specification were not considered valid.

B. Lane Delineation Markings

The New Car Assessment Program's Test Procedure for the confirmation of a Lane Departure Warning system contains a requirement that all lane markings meet United States Department of Transportation (USDOT) specifications as described in the Manual on Uniform Traffic Control Devices (MUTCD) and be considered in "very good condition".

1. Lane Marker Width

The width of the edge line marker was 10 to 15 cm (4 to 6 in). This is considered to be a normal width for longitudinal pavement markings under Section 3A.05 of the MUTCD.

2. Line Marking Color and Reflectivity

Lane marker color and reflectivity met all applicable standards. These standards include those from the International Commission of Illumination (CIE) for color and the American Society for Testing and Materials (ASTM) on lane marker reflectance.

3. Line Styles

The tests described in this document required the use of three lane line configurations: continuous solid white, discontinuous dashed yellow, and discontinuous with raised pavement markers.

- Continuous White Line

A continuous white line is defined as a white line that runs for the entire length of the test course.

- Dashed Yellow Line

As stated in the MUTCD, and as shown in Figure 2, a discontinuous dashed yellow line is defined as by a series of 3 m (10 ft) broken (dashed) yellow line segments, spaced 9.1 m (30 ft) apart.

- Raised Pavement Marker Line (Botts Dots)

California Standard Plans indicates raised pavement markers are commonly used in lieu of painted strips for marking roads in California. Other states, mainly in the southern part of the United States, rely on them as well. These markers may be white or yellow, depending on the specific application, following the same basic colors of their analogous white and yellow painted lines. Following the California 2006 Standard Plans, three types of raised pavement markings are used to form roadway lines. It is believed that these types of roadway markings are the hardest for an LDW sensor system to process. Type A and Type AY are non-reflective circular domes that are approximately 10 cm (4 in) in diameter and approximately 1.8 cm (0.7 in) high. Type C and D are square markings that are retro reflective in two directions measuring approximately 10 x 10 x 5 cm (4 x 4 x 0.5 in), and Type G and H that are the same as C and D only retro reflective in a single direction.

For the tests described in this document, raised pavement markers were set up following California Standard Plan A20A, Detail 4, as shown in Figure 3. Note that in this figure, the squares are Type D yellow reflectors and the circles are yellow Type AY discs.

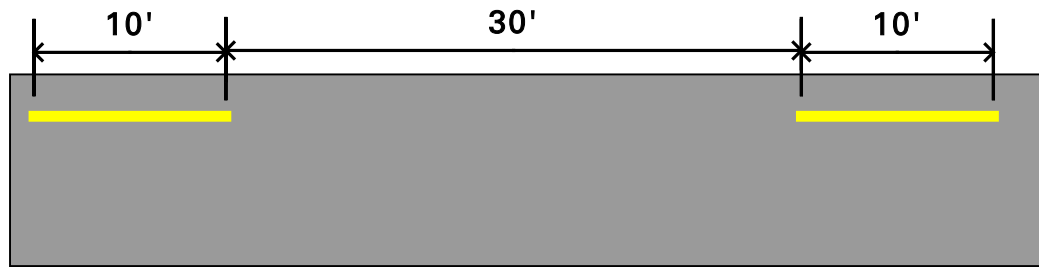

Figure 2. MUTCD Discontinuous Dashed Line Specifications

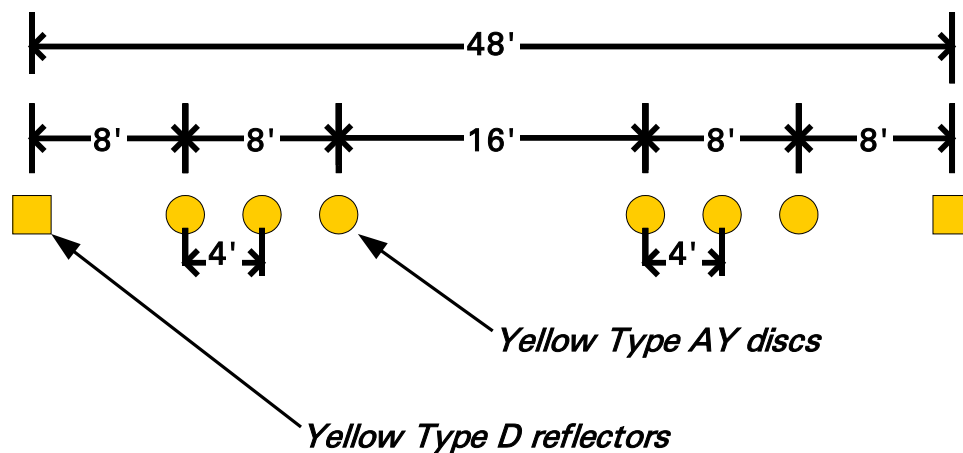

Figure 3. California Standard Plan A20A, Detail 4

C. Test Validity

1. Speed

All LDW tests were conducted at 72.4 km/h (45 mph). Test speed was monitored and a test was considered valid if the test speed remained within ± 2 km/h (± 1.2 mph) of the 72.4 km/h (45 mph) target speed. It was required that the speed must remain within this window from the start of the test until any part of the vehicle crossed a lane line by 1 m (3.3 ft) or more.

2. Lateral Velocity

All tests were conducted with a lateral velocity of 0.1 to 0.6 m/s (0.3 to 2.0 ft/s), measured with respect to the lane line at the time of the alert. To assist the test driver in being able to efficiently establish the target lateral velocity, cones were positioned in the manner shown in Figure 1.

3. Yaw Rate

It was required that the magnitude of the vehicle's yaw rate could not exceed 1.0 deg/sec at any time during lane departure maneuver, from the time the vehicle passes through the start gate to the instant the vehicle has crossed a lane line by 1 m (3.3 ft).

D. Pass/Fail Criteria

The measured test data were used to determine the pass/fail outcome for each trial. The outcome was based on whether the LDW produced an appropriate alert during the maneuver. In the context of this test procedure, a lane departure is said to occur when any part of the two-dimensional polygon used to represent the test vehicle breaches the inboard lane line edge (i.e., the edge of the line close to the vehicle before the departure occurs). In the case of tests performed in this procedure, the front corner of the polygon, defined as the intersection of the center of the front wheels (longitudinally) with the outboard edge of the front tire (laterally), crossed the line edge first. So, for example, if the vehicle departed its lane to the left, the left front corner of the polygon would first breach the lane line edge.

For an individual trial to be considered a "pass":

- Test speed, lateral velocity, and yaw rate validity conditions must be satisfied.
- The LDW alert must not occur when the lateral position of the vehicle is greater than 0.75 m (2.5 ft) from the lane line edge (i.e., prior to the lane departure).
- The LDW alert must occur before the lane departure exceeds 0.3 m (1.0 ft).

For an overall, "Pass" the LDW system must satisfy the pass criteria for 3 of 5 individual trials for each combination of departure direction and lane line type (60%), and pass 20 of the 30 trials overall (66%).

E. Instrumentation

Table 2 lists the sensors, signal conditioning, and data acquisition equipment used for these tests.

Table 2. Test Instrumentation and Equipment

Type	Output	Range	Accuracy, Other Primary Specs	Mfr, Model	Serial Number	Calibration Dates Last Due
Tire Pressure Gauge	Vehicle Tire Pressure	0-100 psi 0-690 kPa	0.5 psi 3.45 kPa	Ashcroft, D1005PS	17042707002	By: DRI Date: 8/18/2020 Due: 8/18/2021
Platform Scales	Vehicle Total, Wheel, and Axle Load	8000 lb 35.6 kN	±1.0% of applied load	Intercomp, SWII	0410MN20001	By: DRI Date: 4/20/2020 Due: 4/20/2021
Differential Global Positioning System	Position, Velocity	Latitude: ±90 deg Longitude: ±180 deg Altitude: 0-18 km Velocity: 0-1000 knots	Horizontal Position: ±1 cm Vertical Position: ±2 cm Velocity: 0.05 km/h	Trimble GPS Receiver, 5700 (base station and in-vehicle)	00440100989	N/A
Multi-Axis Inertial Sensing System	Position: Longitudinal, Lateral, and Vertical Accels: Lateral, Longitudinal and Vertical Velocities: Roll, Pitch, Yaw Rates: Roll, Pitch, Yaw Angles	Latitude: ±90 deg Longitude: ±180 deg Altitude: 0-18 km Velocity: 0-1000 knots Accel: ±100 m/s ² Angular Rate: ±100 deg/s Angular Disp: ±180 deg	Position: ±2 cm Velocity: 0.05 km/h Accel: ≤ 0.01% of full range Angular Rate: ≤ 0.01% of full range Roll/Pitch Angle: ±0.03 deg Heading Angle: ±0.1 deg	Oxford Technical Solutions (OXTS), Inertial+	2258	By: Oxford Technical Solutions ¹ Date: 5/3/2019 Due: 5/3/2021
Real-Time Calculation of Position and Velocity Relative to Lane Markings	Distance and velocity to lane markings	Lateral Lane Dist: ±30 m Lateral Lane Velocity: ±20 m/sec	Lateral Distance to Lane Marking: ±2 cm Lateral Velocity to Lane Marking: ±0.02m/sec	Oxford Technical Solutions (OXTS), RT-Range	97	N/A

¹ Oxford Technical Solutions recommends calibration every two years.

Type	Output	Range	Accuracy, Other Primary Specs	Mfr, Model	Serial Number	Calibration Dates Last Due
Microphone	Sound (to measure time at alert)	Frequency Response: 80 Hz – 20 kHz	Signal-to-noise: 64 dB, 1 kHz at 1 Pa	Audio-Technica AT899	N/A	N/A
Light Sensor	Light intensity (to measure time at alert)	Spectral Bandwidth: 440-800 nm	Rise time < 10 msec	DRI designed and developed Light Sensor	N/A	N/A
Coordinate Measurement Machine	Inertial Sensing System Coordinates	0-8 ft 0-2.4 m	±.0020 in. ±.051 mm (Single point articulation accuracy)	Faro Arm, Fusion	UO8-05-08-06636	By: DRI Date: 1/6/2021 Due: 1/6/2022
Type	Description			Mfr, Model	Serial Number	
Data Acquisition System	Data acquisition is achieved using a dSPACE MicroAutoBox II Data from the Oxford IMU, including Longitudinal, Lateral, and Vertical Acceleration, Roll, Yaw, and Pitch Rate, Forward and Lateral Velocity, Roll and Pitch Angle are sent over Ethernet to the MicroAutoBox. The Oxford IMUs are calibrated per the manufacturer's recommended schedule (listed above).			D-Space Micro-Autobox II 1401/1513		
				Base Board	549068	
				I/O Board	588523	

For systems that implement auditory or haptic alerts, part of the pre-test instrumentation verification process is to determine the tonal frequency of the auditory warning or the vibration frequency of the tactile warning through use of the PSD (Power Spectral Density) function in Matlab. This is accomplished in order to identify the center frequency around which a band-pass filter is applied to subsequent auditory or tactile warning data so that the beginning of such warnings can be programmatically determined. The band-pass filter used for these warning signal types is a phaseless, forward-reverse pass, elliptical (Cauer) digital filter, with filter parameters as listed in Table 3.

Table 3. Auditory and Tactile Warning Filter Parameters

Warning Type	Filter Order	Peak-to-Peak Ripple	Minimum Stop Band Attenuation	Passband Frequency Range
Auditory	5 th	3 dB	60 dB	Identified Center Frequency \pm 5%
Tactile	5 th	3 dB	60 dB	Identified Center Frequency \pm 20%

APPENDIX A

Photographs

LIST OF FIGURES

	Page
Figure A1. Front View of Subject Vehicle.....	A-3
Figure A2. Rear View of Subject Vehicle	A-4
Figure A3. Window Sticker (Monroney Label).....	A-5
Figure A4. Vehicle Certification Label	A-6
Figure A5. Tire Placard	A-7
Figure A6. DGPS, Inertial Measurement Unit, and MicroAutoBox Installed in Subject Vehicle.....	A-8
Figure A7. Sensors for Detecting Visual and Auditory Alerts	A-9
Figure A8. Computer Installed in Subject Vehicle	A-10
Figure A9. LDW Menus.....	A-11
Figure A10. Buttons for Accessing System Setup Menus.....	A-12
Figure A11. LDW Status Indicator/Visual Alert.....	A-13
Figure A12. LDW On/Off Switch	A-14



Figure A1. Front View of Subject Vehicle



Figure A2. Rear View of Subject Vehicle



DESC.: **CAMRY** SE SEDAN
 VIN: **4T1T11AK4MU52**
 YR/MDL: 2021/2546A
 CLR: SUPER WHITE/EA20 (0040/20)
 FINAL ASSEMBLY POINT: GEORGETOWN, KENTUCKY, U.S.A.

STANDARD EQUIPMENT
MECHANICAL & PERFORMANCE
 - 2.5L 4-Cyl Engine
 - 203 hp @ 6600 rpm / 184 lb-ft @ 5000 rpm
 - 8-Speed Transmission w/Paddle Shifters
 - Sport-Tuned Suspension

SAFETY & CONVENIENCE
 - Toyota Safety Sense 2.5+; Pre-Collision Sys w/Pedestrian Detection, Dynamic Radar Cruise Control, Lane Departure Alert w/Steering Assist, Lane Tracing Assist, Automatic High Beams, Road Sign Assist
 - Star Safety System
 - Backup Camera
 - Safety Connect w/ 1-Year Trial

EXTERIOR
 - 18-in Black Machined-Finish Alloy Wheels
 - Bi-LED Combination Headlights w/Auto On/Off Feature
 - LED DRLs w/On/Off Feature
 - Black Front Grille w/Sport Mesh Insert
 - Single Exhaust w/Dual Chrome Tips

INTERIOR
 - Audio - 7-In Touchscreen, 6 Speakers, HandsFree Bluetooth Phone/Music, USB Media Port, 2 USB Charge-Ports, SiriusXM w/3-Month All Access Trial, Android Auto & Apple CarPlay Compatible
 - 4.2-in TFT Multi-Information Display
 - Sport Fabric SofTex-Trimmed Seats
 - Power Driver Seat w/Lumbar Support
 - Auto Climate Control
 - Remote Keyless Entry System

- For Full Product Details Please Visit Toyota.com/camry
 Full Tank of Gas

MANUFACTURER'S SUGGESTED RETAIL PRICE \$26,485.00

OPTIONAL EQUIPMENT		
FE	50 State Emissions Convenience Package	600.00
CP	Smart Key System, Homelink, Auto-Dimming Rearview Mirror	
BD	Blind Spot Monitor with Rear Cross Traffic Alert	680.00
3J	Black Out Badges	129.00
CF	Carpet /Trunk Mat Set	259.00
D5	Door Edge Guard	129.00
DK	PREFERRED OWNER'S PORTFOLIO	
EF	Rear Bumper Applique	69.00

GOVERNMENT 5-STAR SAFETY RATINGS

Overall Vehicle Score ★★★★★
 Based on the combined ratings of frontal, side and rollover. Should ONLY be compared to other vehicles of similar size and weight.

Frontal Crash Driver Passenger ★★★★★
 Based on the risk of injury in a frontal impact. Should ONLY be compared to other vehicles of similar size and weight.

Side Crash Front seat Rear seat ★★★★★
 Based on the risk of injury in a side impact.

Rollover ★★★★★
 Based on the risk of rollover in a single-vehicle crash.

Star ratings range from 1 to 5 stars (★★★★★) with 5 being the highest.
 Source: National Highway Traffic Safety Administration (NHTSA)
www.safercar.gov or 1-888-327-4236

EPA DOT Fuel Economy and Environment

Fuel Economy **32** MPG
 combined city/hwy
 28 city 39 highway
 3.1 gallons per 100 miles
Midsize Cars range from 14 to 141 MPG. The best vehicle rates 141 MPGe.

You save \$1,250
 in fuel costs over 5 years compared to the average new vehicle.

Annual fuel cost \$1,250



fuel economy.gov
 Calculate personalized estimates and compare vehicles

Gasoline Vehicle

DELIVERY PROCESSING AND HANDLING FEE 995.00

TOTAL \$29,346.00

The New Vehicle Limited Warranty provides 3-years/50,000-mile basic coverage, 5-years/100,000-mile powertrain coverage, plus 8-year/unlimited-mile corrosion perforation coverage. See Warranty and Maintenance Guide for details. An extended service contract may be available for the vehicle. Ask dealer for details. Manufacturer's suggested retail price includes manufacturer's recommended pre-delivery service. Gasoline, license and title fees, applicable federal, state and local taxes and dealer and distributor installed options and accessories are not included in the manufacturer's suggested retail price. ToyotaCare, which covers normal factory scheduled maintenance for two years or 25,000 miles, whichever occurs first, is included as part of the sales price of the vehicle for qualifying buyers. See participating dealer for eligibility and coverage details.

Delivered by Truck to:



Figure A3. Window Sticker (Monroney Label)

MFD. BY: TOYOTA MOTOR MANUFACTURING,
KENTUCKY, INC. 11/20

GVWR 4475LB GAWR FR 2620LB RR 2420LB
THIS VEHICLE CONFORMS TO ALL APPLICABLE
FEDERAL MOTOR VEHICLE SAFETY, BUMPER, AND
THEFT PREVENTION STANDARDS IN EFFECT ON
THE DATE OF MANUFACTURE SHOWN ABOVE.
4T1T11AK4MU52 PASS. CAR

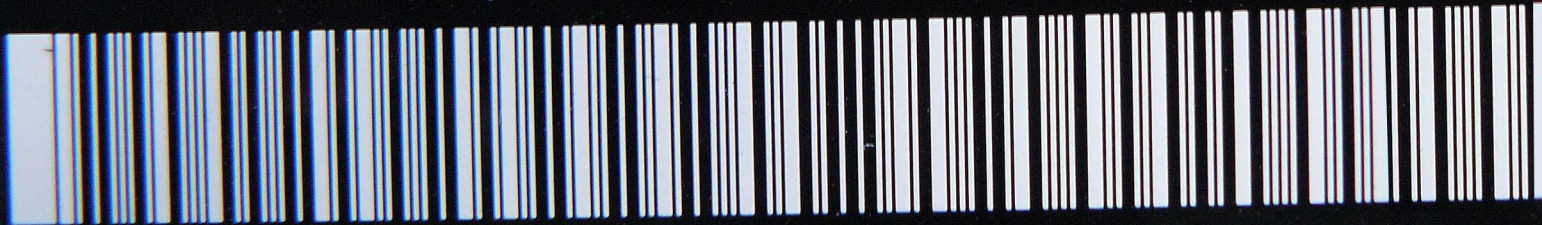

C/TR: 040/EA20 AXVA70L-CEZSBA
A/TM: /UB80E MADE IN U.S.A. 86723

Figure A4. Vehicle Certification Label

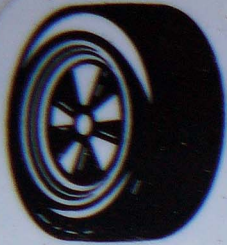

TIRE AND LOADING INFORMATION RENSEIGNEMENTS SUR LES PNEUS ET LE CHARGEMENT

SEATING CAPACITY | TOTAL | FRONT | REAR
NOMBRE DE PLACES | TOTAL: **5** | AVANT: **2** | ARRIÈRE: **3**

The combined weight of occupants and cargo should never exceed 420 kg or 925 lbs.
Le poids total des occupants et du chargement ne doit jamais dépasser 420 kg ou 925 lb.

TIRE PNEU	SIZE DIMENSIONS	COLD TIRE PRESSURE PRESSION DES PNEUS À FROID	SEE OWNER'S MANUAL FOR ADDITIONAL INFORMATION VOIR LE MANUEL DE L'USAGER POUR PLUS DE RENSEIGNEMENTS
FRONT AVANT	235/45R18	240 kPa, 35 PSI	
REAR ARRIÈRE	235/45R18	240 kPa, 35 PSI	
SPARE DE SECOURS	T155/70D17	420 kPa, 60 PSI	

52

42661-06B40

Figure A5. Tire Placard

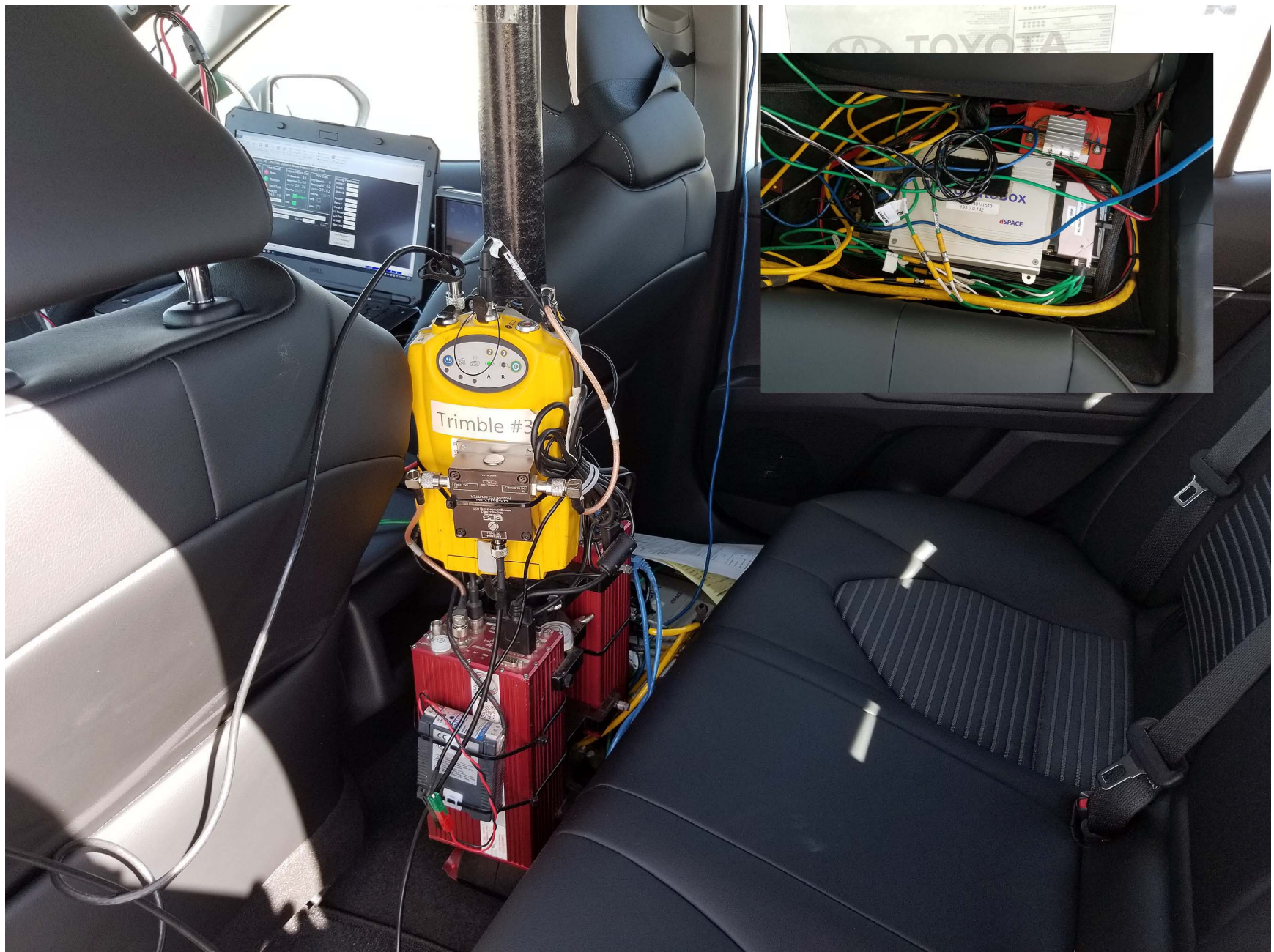

Figure A6. DGPS, Inertial Measurement Unit, and MicroAutoBox Installed in Subject Vehicle



Figure A7. Sensors for Detecting Visual and Auditory Alerts



Figure A8. Computer Installed in Subject Vehicle



Figure A9. LDW Menus



Figure A10. Buttons for Accessing System Setup Menus

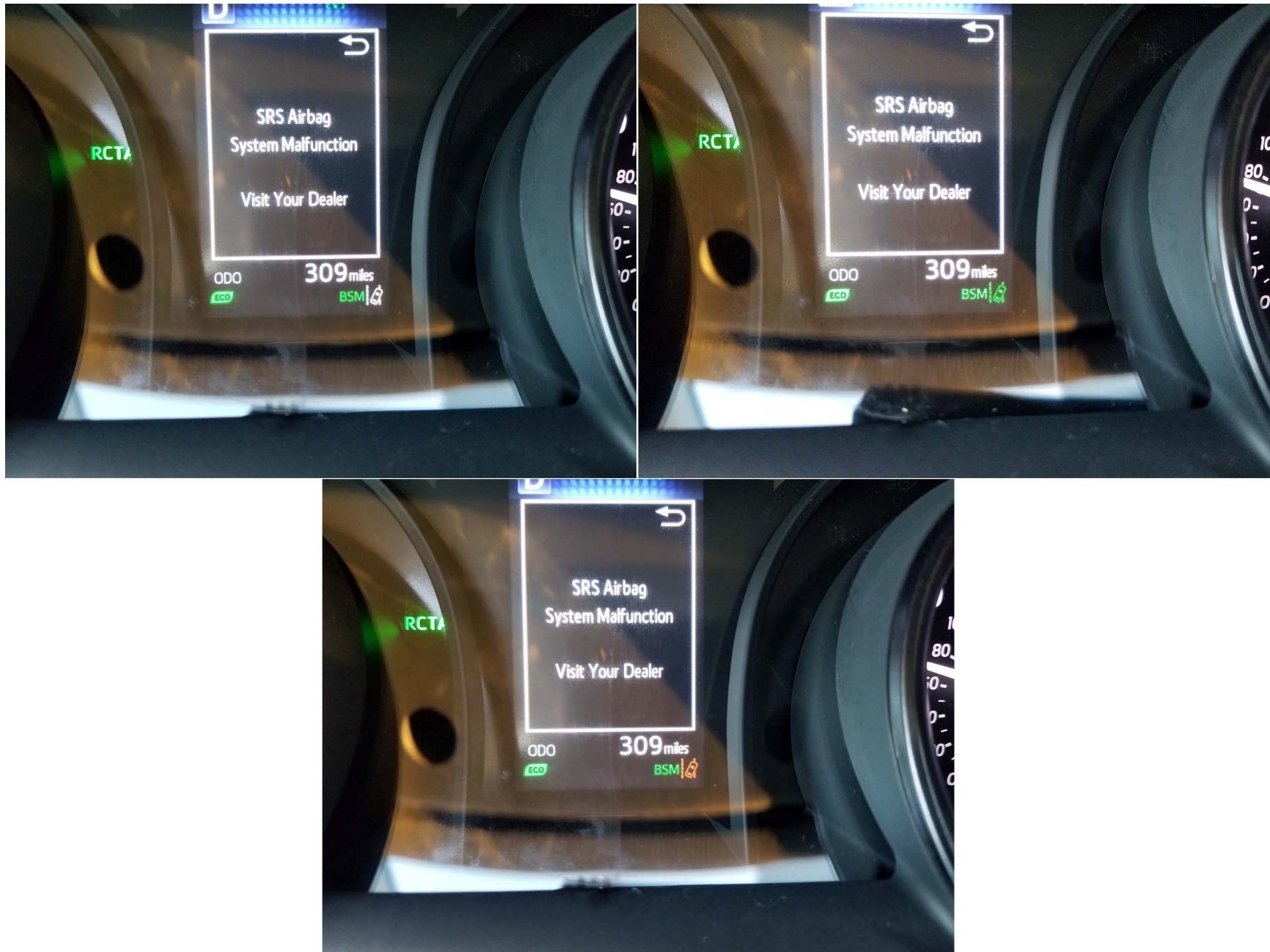

Figure A11. LDW Status Indicator/Visual Alert



Figure A12. LDW On/Off Switch

APPENDIX B

Excerpts from Owner's Manual

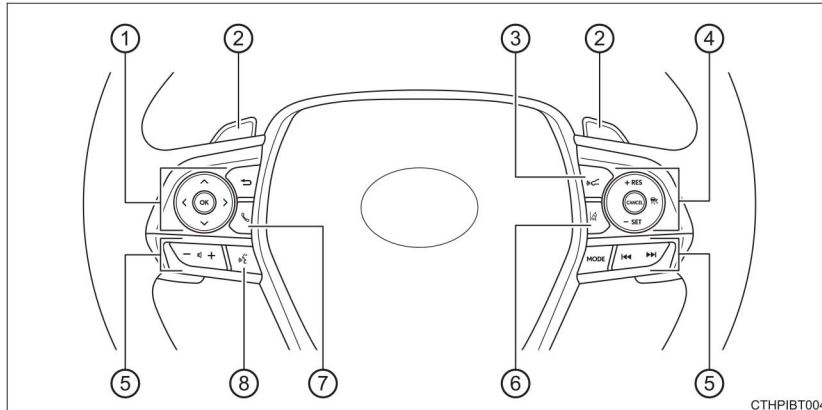

















- ① **Meter control switches** P. 97, 111
- ② **Paddle shift switches^{*1}** P. 219
- ③ **Vehicle-to-vehicle distance button^{*1}** P. 301, 318
- ④ **Cruise control switches**
 Dynamic radar cruise control with full-speed range^{*1} P. 294
 Dynamic radar cruise control^{*1} P. 310
- ⑤ **Audio remote control switches^{*2}**
- ⑥ **LTA (Lane Tracing Assist) switch** P. 274
- ⑦ **Phone switch^{*2}**
- ⑧ **Talk switch^{*2}**

^{*1}: If equipped

^{*2}: Refer to "NAVIGATION AND MULTIMEDIA SYSTEM OWNER'S MANUAL".

Warning lights



















Warning lights inform the driver of malfunctions in the indicated vehicle's systems.

<p>*1  BRAKE (U.S.A.)</p>	<p>Brake system warning light (→P. 538)</p>	<p></p>	<p>Brake Override System/ Drive-Start Control/Parking Support Brake warning light (→P. 539)</p>
<p>*1  (Canada) (Red)</p>	<p>Brake system warning light (→P. 538)</p>	<p> (U.S.A.)</p>	<p>Parking brake indicator (→P. 539)</p>
<p>*1  (if equipped) (Yellow)</p>	<p>Brake system warning light (→P. 538)</p>	<p> (Canada)</p>	<p>Parking brake indicator (→P. 539)</p>
<p>*1  CHECK (U.S.A.)</p>	<p>Malfunction indicator lamp (→P. 538)</p>	<p>*1, 2  (if equipped)</p>	<p>Brake hold operated indicator (→P. 539)</p>
<p>*1  (Canada)</p>	<p>Malfunction indicator lamp (→P. 538)</p>	<p>*1  (Red/yellow)</p>	<p>Electric power steering system warning light (→P. 539)</p>
<p>*1  (U.S.A.)</p>	<p>SRS warning light (→P. 538)</p>	<p>*1  (Yellow)</p>	<p>LTA indicator (→P. 539)</p>
<p>*1  ABS (U.S.A.)</p>	<p>ABS warning light (→P. 538)</p>	<p>*1  OFF (Flashes or illuminates)</p>	<p>PCS warning light (→P. 540)</p>
<p>*1  (Canada)</p>	<p>ABS warning light (→P. 538)</p>	<p>*1, 2  OFF (if equipped)</p>	<p>PKSB OFF indicator (→P. 540)</p>

2
Instrument cluster

Indicators

The indicators inform the driver of the operating state of the vehicle's various systems.

	Turn signal indicator (→P. 225)	^{*1} 	Brake hold standby indicator (→P. 231) (if equipped)
	Headlight indicator (→P. 233) (U.S.A.)		Cruise control indicator (→P. 294, 310)
	Tail light indicator (→P. 233) (Canada)		Dynamic radar cruise control indicator (→P. 294, 310)
	Headlight high beam indicator (→P. 234)		Cruise control "SET" indicator (→P. 294, 310)
^{*1} 	Automatic High Beam indicator (→P. 238)	^{*1, 3} 	PCS warning light (→P. 258)
^{*1, 2} 	Eco driving indicator (→P. 107, 124)	^{*1, 3} 	PKSB OFF indicator (→P. 362) (if equipped)
	Parking brake indicator (→P. 226, 227) (U.S.A.)		LTA indicator (→P. 283) (White)
	Parking brake indicator (→P. 226, 227) (Canada)		LTA indicator (→P. 259, 283) (Green)
^{*1} 	Brake hold operated indicator (→P. 231) (if equipped)	^{*4} 	LTA indicator (→P. 283) (Yellow)

2

Instrument cluster

Menu icons

Select a menu icon to display its content.



Drive information (→P. 99)

Select to display various drive data.



Audio system-linked display

Select to enable selection of an audio source or track on the meter using the meter control switches.



Driving assist system information

Select to display the operational status of the following systems:

- Dynamic radar cruise control with full-speed range (if equipped) (→P. 294)
- Dynamic radar cruise control (if equipped) (→P. 310)
- LTA (Lane Tracing Assist) (→P. 274)
- RSA (Road Sign Assist) (if equipped) (→P. 289)



Warning message display (→P. 548)

Select to display warning messages and measures to be taken if a malfunction is detected.



Settings display (→P. 101)

Select to change the meter display settings and other settings.

Settings display (⚙)

◆ Changing settings

Use the meter control switches on the steering wheel to change settings.

- 1 Press < or > to select ⚙.
- 2 Operate the switches to select a desired item.
- 3 Change the setting by referring to the message displayed on the screen.

◆ Setting items

■ LTA (Lane Tracing Assist) (→P. 274)

The following LTA system settings can be changed:

Item	Settings	Details
Lane center	On	Select to enable/disable the lane centering function.
	Off	
Alert sensitivity	High	Select to set the warning sensitivity.
	Normal	
Sway warning	On	Select to enable/disable the vehicle sway warning.
	Off	
Sway sensitivity	High	Select to set the vehicle sway warning sensitivity.
	Medium	
	Low	

Multi-information display (7-inch display)

Summary of functions

The multi-information display presents the driver with a variety of driving-related data, such as the current outside temperature. The multi-information display can also be used to change the display settings and other settings.

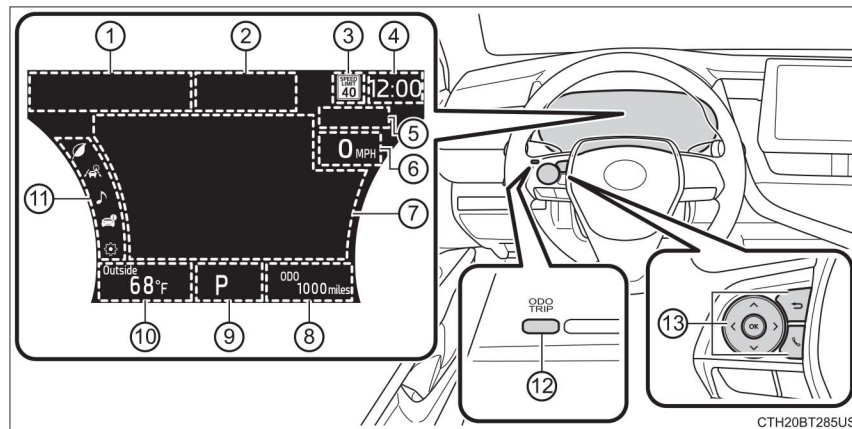

- ① Indicators (→P. 89)
- ② Driving assist system status display area
Displays the operational status of the following systems:
 - Dynamic radar cruise control with full-speed range (if equipped) (→P. 294)
 - Dynamic radar cruise control (if equipped) (→P. 310)
 - LTA (Lane Tracing Assist) (→P. 274)
- ③ Speed limit display (vehicles with a navigation system)
(U.S.A. only) /RSA (Road Sign Assist) (if equipped) (→P. 289)
- ④ Clock
For clock settings, refer to “NAVIGATION AND MULTIMEDIA SYSTEM OWNER’S MANUAL”.
- ⑤ RSA (Road Sign Assist) (if equipped) (→P. 289)
- ⑥ Speedometer
The speedometer display can be enabled/disabled in  on the multi-information display. (→P. 115)

Menu icons

Select a menu icon to display its content.



Warning message display (→P. 548)

This menu icon will be displayed only when a warning message can be displayed.

Select to display warning messages and measures to be taken if a malfunction is detected.



Eco-friendly driving information (→P. 113)

Select to display fuel consumption data in various forms.



Driving assist system information

Select to perform the following:

Display the operational status of the following systems:

- Dynamic radar cruise control with full-speed range (if equipped) (→P. 294)
- Dynamic radar cruise control (if equipped) (→P. 310)
- LTA (Lane Tracing Assist) (→P. 274)
- RSA (Road Sign Assist) (if equipped) (→P. 289)

Display the following navigation system-linked information (if equipped):

- Route guidance
- Compass display



Audio system-linked display

Select to enable selection of an audio source or track on the meter using the meter control switches.



Vehicle information

Select to perform the following:

Display the following information:

- Tire inflation pressure (→P. 483)

Enable/Disable the following systems:

- Intuitive parking assist (if equipped) (→P. 342)
- BSM (Blind Spot Monitor) function (if equipped) (→P. 334)
- RCTA (Rear Cross Traffic Alert) function (if equipped) (→P. 350)

This function can also be enabled/disabled on .



Settings display (→P. 115)

Select to change the meter display settings and other settings.

◆ **Setting items**



■  **LTA (Lane Tracing Assist) (→P. 274)**

Press and hold  to change the settings of the following items:

Item	Settings	Details
Lane center	On	Select to enable/disable the lane centering function.
	Off	
Alert sensitivity	High	Select to set the warning sensitivity.
	Normal	
Sway warning	On	Select to enable/disable the vehicle sway warning.
	Off	
Sway sensitivity	High	Select to set the vehicle sway warning sensitivity.
	Medium	
	Low	



■  **PCS (Pre-Collision System) (→P. 258)**

Press and hold  to change the settings of the following items:

Item	Settings	Details
PCS	On	Select to enable/disable the pre-collision system.
	Off	
Warning sensitivity	 Early	Select to change the warning timing.
	 Middle	
	 Late	

■  **DRCC (Dynamic radar cruise control) (→P. 294, 310)**

Press and hold  to change the settings of the following item:

Item	Settings	Details
Curve speed reduction	 Strong	Select to change the vehicle speed reduction strength.
	 Weak	
	Off	

Driving assist system status/navigation system-linked display area (if equipped)

◆ **Driving assist system status display**

Displays the operational status of the following systems:

- Dynamic radar cruise control with full-speed range (→P. 294)
- LTA (Lane Tracing Assist) (→P. 274)
- RSA (Road Sign Assist) (if equipped) (→P. 289)
- Intuitive parking assist (if equipped) (→P. 342)

◆ **Navigation system-linked display area (if equipped)**

Displays the following items, which are linked to the navigation system:

■ **Street name**

When the navigation system is performing route guidance, the name of the next street will be displayed on the top of the display area.

■ **Route guidance to destination**

Displayed when the navigation system is performing route guidance. When approaching an intersection, an arrow will be displayed to indicate the suggested direction of travel.

■ **Compass**

Displays the direction of travel.

Eco Driving Indicator/Tachometer

■ Eco Driving Indicator

- ① Eco Driving Indicator Zone Display
- ② Eco driving ratio based on acceleration
- ③ Zone of Eco driving

Displayed content is the same as that displayed on the multi-information display (Eco Driving Indicator). For details, refer to P. 124.

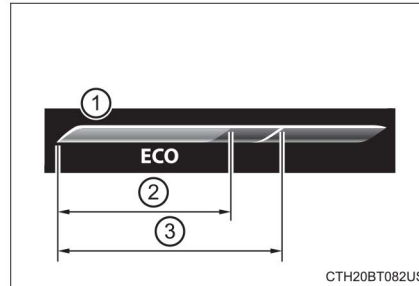

■ Tachometer

Displays the engine speed in revolutions per minute.

Information display area

Displays the following items in the appropriate situation:

■ Warning/Message

- Alert from the LTA (Lane Tracing Assist)
- Dynamic radar cruise control with full-speed range
-  message

Displayed when a suggestion/advice pop-up display is displayed on the multi-information display. (→P. 123)

-  message

Displayed when a warning message is displayed on the multi-information display. (→P. 548)

- Outside temperature

Displayed in the following situations:

- When the engine switch is turned to IGNITION ON mode
- When the low outside temperature indicator is flashing

Displayed content is the same as that displayed on the multi-information display. For details, refer to the explanation of the outside temperature display on the multi-information display. (→P. 92)

■ Hands-free system status

Displayed when the hands-free system is operated.

■ Audio system operation status

Displayed when the audio system is operated.

Toyota Safety Sense 2.5+

The Toyota Safety Sense 2.5+ consists of the following drive assist systems and contributes to a safe and comfortable driving experience:

Driving assist system

◆ **PCS (Pre-Collision System)**

→P. 258

◆ **LTA (Lane Tracing Assist)**

→P. 274

◆ **AHB (Automatic High Beam)**

→P. 238

◆ **RSA (Road Sign Assist) (if equipped)**

→P. 289

◆ **Dynamic radar cruise control with full-speed range (if equipped)**

→P. 294

◆ **Dynamic radar cruise control (if equipped)**

→P. 310

 **WARNING**

■ **Toyota Safety Sense 2.5+**

The Toyota Safety Sense 2.5+ is designed to operate under the assumption that the driver will drive safely, and is designed to help reduce the impact to the occupants and the vehicle in the case of a collision or assist the driver in normal driving conditions.

As there is a limit to the degree of recognition accuracy and control performance that this system can provide, do not overly rely on this system. The driver is always responsible for paying attention to the vehicle's surroundings and driving safely.

Sensors

Two types of sensors, located behind the front grille and windshield, detect information necessary to operate the drive assist systems.

- ① Radar sensor
- ② Front camera

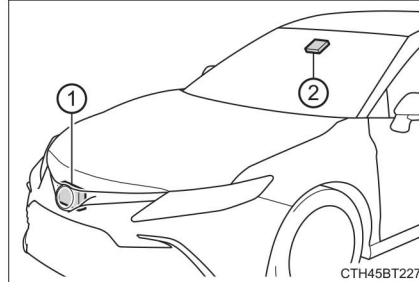

WARNING

To avoid malfunction of the radar sensor

Observe the following precautions.

Otherwise, the radar sensor may not operate properly, possibly leading to an accident resulting in death or serious injury.

- Keep the radar sensor and the radar sensor cover clean at all times.

- ① Radar sensor
- ② Radar sensor cover

If the front of the radar sensor or the front or back of the radar sensor cover is dirty or covered with water droplets, snow, etc., clean it.

Clean the radar sensor and radar sensor cover with a soft cloth to avoid damaging them.

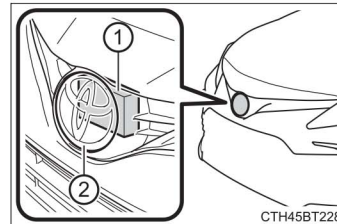

- Do not attach accessories, stickers (including transparent stickers) or other items to the radar sensor, radar sensor cover or surrounding area.
- Do not subject the radar sensor or its surrounding area to a strong impact. If the radar sensor, front grille, or front bumper has been subjected to a strong impact, have the vehicle inspected by your Toyota dealer.
- Do not disassemble the radar sensor.
- Do not modify or paint the radar sensor or radar sensor cover.
- In the following cases, the radar sensor must be recalibrated. Contact your Toyota dealer for details.
 - When the radar sensor or front grille are removed and installed, or replaced
 - When the front bumper is replaced

! WARNING

■ To avoid malfunction of the front camera

Observe the following precautions.

Otherwise, the front camera may not operate properly, possibly leading to an accident resulting in death or serious injury.

- Keep the windshield clean at all times.
 - If the windshield is dirty or covered with an oily film, water droplets, snow, etc., clean the windshield.
 - If a glass coating agent is applied to the windshield, it will still be necessary to use the windshield wipers to remove water droplets, etc. from the area of the windshield in front of the front camera.
 - If the inner side of the windshield where the front camera is installed is dirty, contact your Toyota dealer.

- Do not attach objects, such as stickers, transparent stickers, etc., to the outer side of the windshield in front of the front camera (shaded area in the illustration).

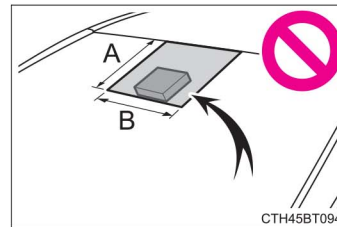

A: From the top of the windshield to approximately 0.4 in. (1 cm) below the bottom of the front camera

B: Approximately 7.9 in. (20 cm) (Approximately 4.0 in. [10 cm] to the right and left from the center of the front camera)

- If the part of the windshield in front of the front camera is fogged up or covered with condensation or ice, use the windshield defogger to remove the fog, condensation or ice. (→P. 393, 399, 407)
- If water droplets cannot be properly removed from the area of the windshield in front of the front camera by the windshield wipers, replace the wiper insert or wiper blade.
- Do not attach window tint to the windshield.
- Replace the windshield if it is damaged or cracked.
After replacing the windshield, the front camera must be recalibrated. Contact your Toyota dealer for details.
- Do not allow liquids to contact the front camera.
- Do not allow bright lights to shine into the front camera.
- Do not dirty or damage the front camera.
When cleaning the inside of the windshield, do not allow glass cleaner to contact the lens of the front camera. Also, do not touch the lens.
If the lens is dirty or damaged, contact your Toyota dealer.

 **WARNING**

- Do not subject the front camera to a strong impact.
- Do not change the installation position or direction of the front camera or remove it.
- Do not disassemble the front camera.
- Do not modify any components of the vehicle around the front camera (inside rear view mirror, etc.) or ceiling.
- Do not attach any accessories to the hood, front grille or front bumper that may obstruct the front camera. Contact your Toyota dealer for details.
- If a surfboard or other long object is to be mounted on the roof, make sure that it will not obstruct the front camera.
- Do not modify the headlights or other lights.

■ **If a warning message is displayed on the multi-information display**

A system may be temporarily unavailable or there may be a malfunction in the system.

- In the following situations, perform the actions specified in the table. When the normal operating conditions are detected, the message will disappear and the system will become operational.

If the message does not disappear, contact your Toyota dealer.

Situation	Action
When the area around a camera is covered with dirt, moisture (fogged up, covered with condensation, ice, etc.), or other foreign matter	Using the wiper and A/C function, remove the dirt and other attached matter. (→P. 393, 399, 407)
When the temperature around the front camera is outside of the operational range, such as when the vehicle is in the sun or in an extremely cold environment	If the front camera is hot, such as after the vehicle had been parked in the sun, use the air conditioning system to decrease the temperature around the front camera. If a sunshade was used when the vehicle was parked, depending on its type, the sunlight reflected from the surface of the sunshade may cause the temperature of the front camera to become excessively high.
	If the front camera is cold, such after the vehicle is parked in an extremely cold environment, use the air conditioning system to increase the temperature around the front camera.
The area in front of the front camera is obstructed, such as when the hood is open or a sticker is attached to the part of the windshield in front of the front camera.	Close the hood, remove the sticker, etc. to clear the obstruction.
When “Pre-Collision System Unavailable See Owner’s Manual” is displayed	Check whether there is attached materials on the radar sensor and radar sensor cover, and if there is, remove it.

-
- In the following situations, if the situation has changed (or the vehicle has been driven for some time) and the normal operating conditions are detected, the message will disappear and the system will become operational.

If the message does not disappear, contact your Toyota dealer.

- When the temperature around the radar sensor is outside of the operational range, such as when the vehicle is in the sun or in an extremely cold environment
- When the front camera cannot detect objects in front of the vehicle, such as when driving in the dark, snow, or fog, or when bright lights are shining into the front camera
- Depending on the conditions in the vicinity of the vehicle, the radar may judge the surrounding environment cannot be properly recognized. In that case, "Pre-Collision System Unavailable See Owner's Manual" is displayed.

LTA (Lane Tracing Assist)

Summary of functions

While driving on a road with clear white (yellow) lane lines, the LTA system warns the driver if the vehicle may deviate from the current lane or course*, and also can slightly operate the steering wheel to help avoid deviation from the lane or course*. Also, while the dynamic radar cruise control with full-speed range or dynamic radar cruise control is operating, this system will operate the steering wheel to maintain the vehicle's lane position.

The LTA system recognizes white (yellow) lane lines or a course* using the front camera. Additionally, it detects preceding vehicles using the front camera and radar.

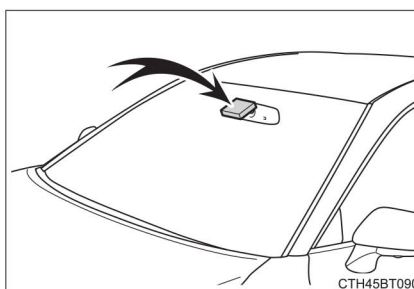

*: Boundary between asphalt and the side of the road, such as grass, soil, or a curb

WARNING

■ Before using LTA system

- Do not rely solely upon the LTA system. The LTA system does not automatically drive the vehicle or reduce the amount of attention that must be paid to the area in front of the vehicle. The driver must always assume full responsibility for driving safely by paying careful attention to the surrounding conditions and operating the steering wheel to correct the path of the vehicle. Also, the driver must take adequate breaks when fatigued, such as from driving for a long period of time.
- Failure to perform appropriate driving operations and pay careful attention may lead to an accident, resulting in death or serious injury.

 **WARNING****■ Situations unsuitable for LTA system**

In the following situations, use the LTA switch to turn the system off. Failure to do so may lead to an accident, resulting in death or serious injury.

- Vehicle is driven on a road surface which is slippery due to rainy weather, fallen snow, freezing, etc.
- Vehicle is driven on a snow-covered road.
- White (yellow) lines are difficult to see due to rain, snow, fog, dust, etc.
- Vehicle is driven in a temporary lane or restricted lane due to construction work.
- Vehicle is driven in a construction zone.
- A spare tire, tire chains, etc. are equipped.
- When the tires have been excessively worn, or when the tire inflation pressure is low.
- During emergency towing

■ Preventing LTA system malfunctions and operations performed by mistake

- Do not modify the headlights or place stickers, etc. on the surface of the lights.
- Do not modify the suspension etc. If the suspension etc. needs to be replaced, contact your Toyota dealer.
- Do not install or place anything on the hood or grille. Also, do not install a grille guard (bull bars, kangaroo bar, etc.).
- If your windshield needs repairs, contact your Toyota dealer.

! WARNING

■ Conditions in which functions may not operate properly

In the following situations, the functions may not operate properly and the vehicle may depart from its lane. Drive safely by always paying careful attention to your surroundings and operate the steering wheel to correct the path of the vehicle without relying solely on the functions.

- When the follow-up cruising display is displayed (→P. 284) and the preceding vehicle changes lanes. (Your vehicle may follow the preceding vehicle and also change lanes.)

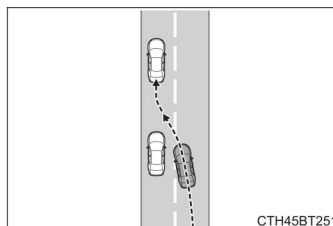

- When the follow-up cruising display is displayed (→P. 284) and the preceding vehicle is swaying. (Your vehicle may sway accordingly and depart from the lane.)
- When the follow-up cruising display is displayed (→P. 284) and the preceding vehicle departs from its lane. (Your vehicle may follow the preceding vehicle and depart from the lane.)
- When the follow-up cruising display is displayed (→P. 284) and the preceding vehicle is being driven extremely close to the left/right lane line. (Your vehicle may follow the preceding vehicle and depart from the lane.)
- Vehicle is being driven around a sharp curve.
- Objects or patterns that could be mistaken for white (yellow) lines are present on the side of the road (guardrails, reflective poles, etc.).

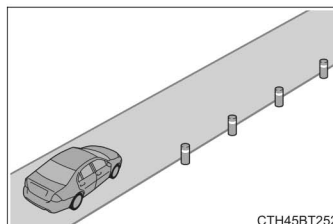

! WARNING

- Vehicle is driven where the road diverges, merges, etc.

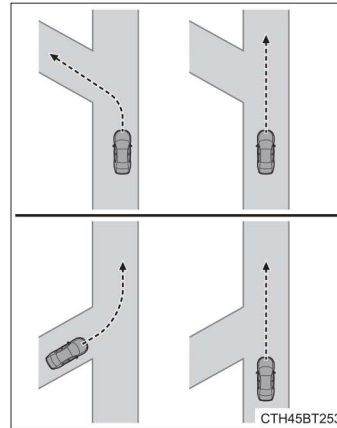

- Repair marks of asphalt, white (yellow) lines, etc. are present due to road repair.

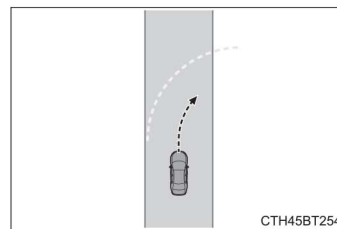

- There are shadows on the road that run parallel with, or cover, the white (yellow) lines.
- The vehicle is driven in an area without white (yellow) lines, such as in front of a tollgate or checkpoint, or at an intersection, etc.
- The white (yellow) lines are cracked, “Botts’ dots”, “Raised pavement marker” or stones are present.
- The white (yellow) lines cannot be seen or are difficult to see due to sand, etc.
- The vehicle is driven on a road surface that is wet due to rain, puddles, etc.
- The traffic lines are yellow (which may be more difficult to recognize than lines that are white).
- The white (yellow) lines cross over a curb, etc.
- The vehicle is driven on a bright surface, such as concrete.
- If the edge of the road is not clear or straight.
- The vehicle is driven on a surface that is bright due to reflected light, etc.
- The vehicle is driven in an area where the brightness changes suddenly, such as at the entrances and exits of tunnels, etc.

4

Driving

 WARNING

- Light from the headlights of an oncoming vehicle, the sun, etc. enters the camera.
- The vehicle is driven on a slope.
- The vehicle is driven on a road which tilts left or right, or a winding road.
- The vehicle is driven on an unpaved or rough road.
- The traffic lane is excessively narrow or wide.
- The vehicle is extremely tilted due to carrying heavy luggage or having improper tire pressure.
- The distance to the preceding vehicle is extremely short.
- The vehicle is moving up and down a large amount due to road conditions during driving (poor roads or road seams).
- When driving in a tunnel or at night with the headlights off or when a headlight is dim due to its lens being dirty or it being misaligned.
- The vehicle is struck by a crosswind.
- The vehicle is affected by wind from a vehicle driven in a nearby lane.
- The vehicle has just changed lanes or crossed an intersection.
- Tires which differ by structure, manufacturer, brand or tread pattern are used.
- When tires of a size other than specified are installed.
- Snow tires, etc. are equipped.
- The vehicle is being driven at extremely high speeds.

Functions included in LTA system**◆ Lane departure alert function**

When the system determines that the vehicle might depart from its lane or course*, a warning is displayed on the multi-information display, and a warning buzzer will sound to alert the driver.

When the warning buzzer sounds, check the area around your vehicle and carefully operate the steering wheel to move the vehicle back to the center of the lane.

Vehicle with BSM: When the system determines that the vehicle might depart from its lane and that the possibility of a collision with an overtaking vehicle in the adjacent lane is high, the lane departure alert will operate even if the turn signals are operating.

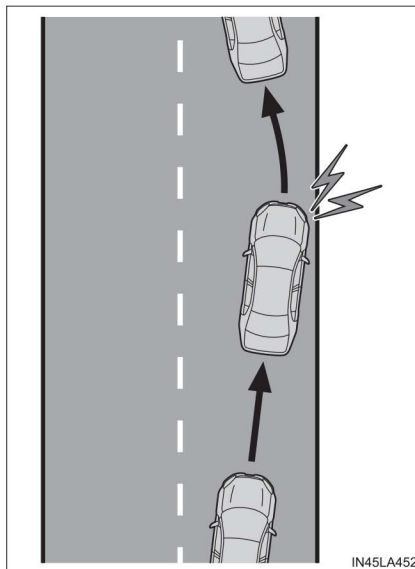

4

Driving

*: Boundary between asphalt and the side of the road, such as grass, soil, or a curb

◆ **Steering assist function**

When the system determines that the vehicle might depart from its lane or course*, the system provides assistance as necessary by operating the steering wheel in small amounts for a short period of time to keep the vehicle in its lane.

Vehicle with BSM: When the system determines that the vehicle might depart from its lane and that the possibility of a collision with an overtaking vehicle in the adjacent lane is high, the steering assist function will operate even if the turn signals are operating.

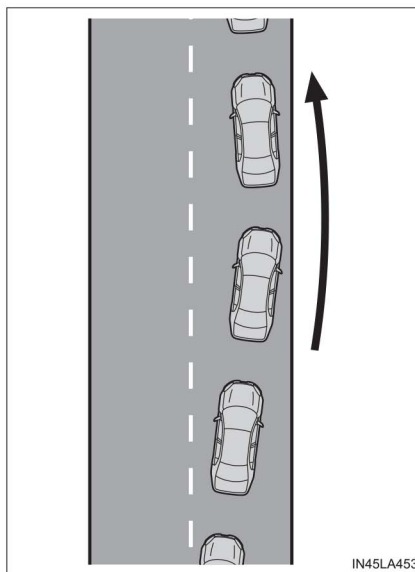

*: Boundary between asphalt and the side of the road, such as grass, soil, or a curb

◆ **Vehicle sway warning function**

When the vehicle is swaying within a lane, the warning buzzer will sound and a message will be displayed on the multi-information display to alert the driver.

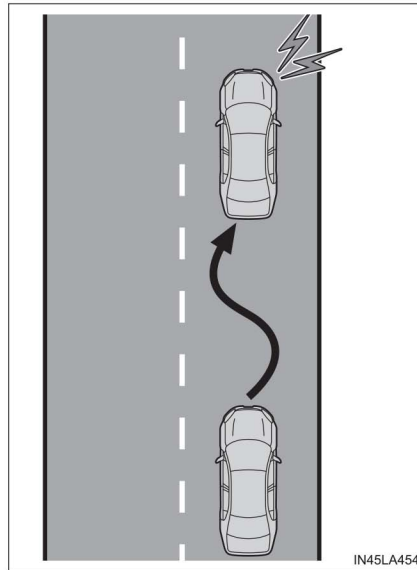

4
Driving

◆ **Lane centering function**

This function is linked with dynamic radar cruise control with full-speed range or dynamic radar cruise control and provides the required assistance by operating the steering wheel to keep the vehicle in its current lane.

When dynamic radar cruise control with full-speed range or dynamic radar cruise control is not operating, the lane centering function does not operate.

In situations where the white (yellow) lane lines are difficult to see or are not visible, such as when in a traffic jam, this function will operate to help follow a preceding vehicle by monitoring the position of the preceding vehicle.

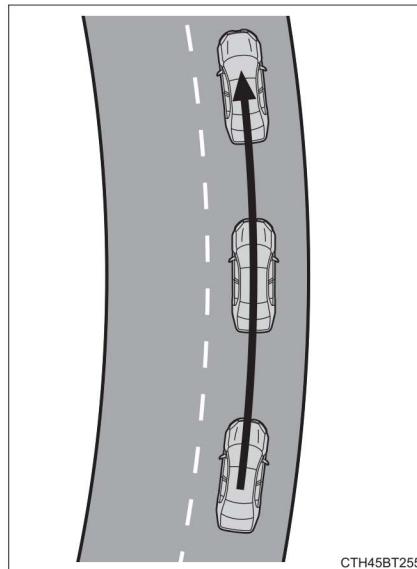

Turning LTA system on

Press the LTA switch to turn the LTA system on.

The LTA indicator illuminates and a message is displayed on the multi-information display.

Press the LTA switch again to turn the LTA system off.

When the LTA system is turned on or off, operation of the LTA system continues in the same condition the next time the engine is started.

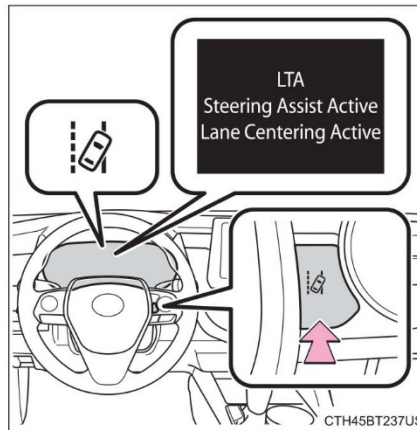

Indications on the multi-information display

The illustration used is intended as an example, and may differ from the image that is actually displayed on the multi-information display.

① LTA indicator

The illumination condition of the indicator informs the driver of the system operation status.

Illuminated in white:
LTA system is operating.

Illuminated in green:
Steering wheel assistance of the steering assist function or lane centering function is operating.

Flashing in yellow:
Lane departure alert function is operating.

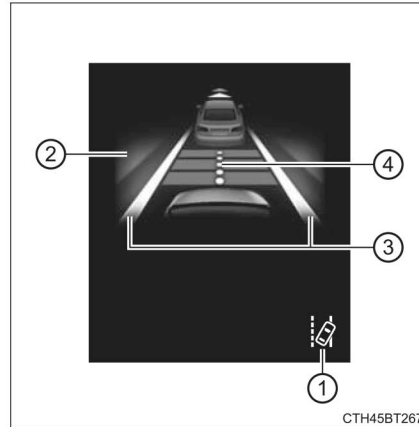

② Operation display of steering wheel operation support

Displayed when the multi-information display is switched to the driving assist system information display.

Indicates that steering wheel assistance of the steering assist function or lane centering function is operating.

Both outer sides of the lane are displayed: Indicates that steering wheel assist of the lane centering function is operating.

One outer side of the lane is displayed: Indicates that steering wheel assist of the steering assist function is operating.

Both outer sides of the lane are flashing: Alerts the driver that their input is necessary to stay in the center of the lane (lane centering function).

③ Lane departure alert function display

Displayed when the multi-information display is switched to the driving assist system information display.

- ▶ Inside of displayed lines is white
- ▶ Inside of displayed lines is black

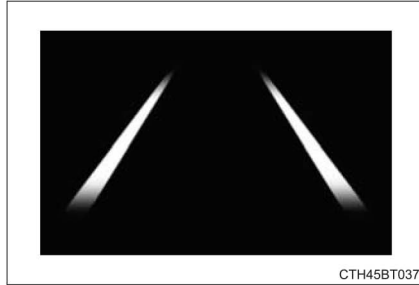

Indicates that the system is recognizing white (yellow) lines or a course*. When the vehicle departs from its lane, the white line displayed on the side the vehicle departs from flashes yellow.

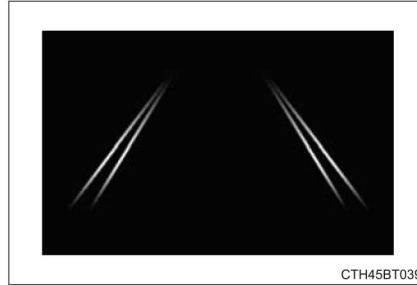

Indicates that the system is not able to recognize white (yellow) lines or a course* or is temporarily canceled.

*: Boundary between asphalt and the side of the road, such as grass, soil, or a curb

④ Follow-up cruising display

Displayed when the multi-information display is switched to the driving assist system information display.

Indicates that steering assist of the lane centering function is operating by monitoring the position of a preceding vehicle.

When the follow-up cruising display is displayed, if the preceding vehicle moves, your vehicle may move in the same way. Always pay careful attention to your surroundings and operate the steering wheel as necessary to correct the path of the vehicle and ensure safety.

■ Operation conditions of each function

● Lane departure alert function

This function operates when all of the following conditions are met.

- LTA is turned on.
- Vehicle speed is approximately 32 mph (50 km/h) or more.*1
- System recognizes white (yellow) lane lines or a course*2. (When a white [yellow] line or course*2 is recognized on only one side, the system will operate only for the recognized side.)
- Width of traffic lane is approximately 9.8 ft. (3 m) or more.
- Turn signal lever is not operated. (Vehicle with BSM: Except when another vehicle is in the lane on the side where the turn signal was operated)
- Vehicle is not being driven around a sharp curve.
- No system malfunctions are detected. (→P. 288)

*1: The function operates even if the vehicle speed is less than approximately 32 mph (50 km/h) when the lane centering function is operating.

*2: Boundary between asphalt and the side of the road, such as grass, soil, or a curb



● Steering assist function

This function operates when all of the following conditions are met in addition to the operation conditions for the lane departure alert function.

- Vehicle is not accelerated or decelerated by a fixed amount or more.
- Steering wheel is not operated with a steering force level suitable for changing lanes.
- ABS, VSC, TRAC and PCS are not operating.
- TRAC or VSC is not turned off.



● Vehicle sway warning function

This function operates when all of the following conditions are met.

- Setting for “Sway Warning” in  (4.2-inch display) or  (7-inch display) of the multi-information display is set to “On”. (→P. 96, 109)
- Vehicle speed is approximately 32 mph (50 km/h) or more.
- Width of traffic lane is approximately 9.8 ft. (3 m) or more.
- No system malfunctions are detected. (→P. 288)

● Lane centering function

This function operates when all of the following conditions are met.

- LTA is turned on.
- Setting for “Lane Center” in  (4.2-inch display) or  (7-inch display) of the multi-information display is set to “ON”. (→P. 96, 109)
- This function recognizes white (yellow) lane lines or the position of a preceding vehicle (except when the preceding vehicle is small, such as a motorcycle).

- The dynamic radar cruise control with full-speed range or dynamic radar cruise control is operating in vehicle-to-vehicle distance control mode.
- Width of traffic lane is approximately 10 to 13 ft. (3 to 4 m).
- Turn signal lever is not operated.
- Vehicle is not being driven around a sharp curve.
- No system malfunctions are detected. (→P. 288)
- Vehicle does not accelerate or decelerate by a fixed amount or more.
- Steering wheel is not operated with a steering force level suitable for changing lanes.
- ABS, VSC, TRAC and PCS are not operating.
- TRAC or VSC is not turned off.
- Hands off steering wheel warning is not displayed. (→P. 287)
- The vehicle is being driven in the center of a lane.
- Steering assist function is not operating.

■ Temporary cancelation of functions

- When operation conditions are no longer met, a function may be temporarily canceled. However, when the operation conditions are met again, operation of the function is automatically restored. (→P. 285)
- If the operation conditions (→P. 285) are no longer met while the lane centering function is operating, the buzzer may sound to indicate that the function has been temporarily canceled.

■ Steering assist function/lane centering function

- Depending on the vehicle speed, lane departure situation, road conditions, etc., the driver may not feel the function is operating or the function may not operate at all.
- The steering control of the function is overridden by the driver's steering wheel operation.
- Do not attempt to test the operation of the steering assist function.

■ Lane departure alert function

- The warning buzzer may be difficult to hear due to external noise, audio playback, etc.
- If the edge of the course* is not clear or straight, the lane departure alert function may not operate.
- Vehicle with BSM: It may not be possible for the system to determine if there is a danger of a collision with a vehicle in an adjacent lane.
- Do not attempt to test the operation of the lane departure alert function.

*: Boundary between asphalt and the side of the road, such as grass, soil, or a curb

■ Hands off steering wheel warning

In the following situations, a warning message urging the driver to hold the steering wheel and the symbol shown in the illustration are displayed on the multi-information display to warn the driver. The warning stops when the system determines that the driver holds the steering wheel. Always keep your hands on the steering wheel when using this system, regardless of warnings.



- When the system determines the driver is not holding the steering wheel while the lane centering function is operating.

If the driver continues to keep their hands off of the steering wheel, the buzzer sounds, the driver is warned and the function is temporarily canceled. This warning also operates in the same way when the driver continuously operates the steering wheel only a small amount.

- When the system determines that the vehicle may deviate from the lane while driving around a curve while the lane centering function is operating.

Depending on the vehicle condition and road conditions, the warning may not operate. Also, if the system determines that the vehicle is driving around a curve, warnings will occur earlier than during straight-lane driving.

- When the system determines that the driver is driving without holding the steering wheel while the steering wheel assist of the steering assist function is operating.

If the driver continues to keep their hands off of the steering wheel and the steering wheel assist is operating, the buzzer sounds and the driver is warned. Each time the buzzer sounds, the continuing time of the buzzer becomes longer.

■ Vehicle sway warning function

When the system determines that the vehicle is swaying while the vehicle sway warning function is operating, a buzzer sounds and a warning message urging the driver to rest and the symbol shown in the illustration are simultaneously displayed on the multi-information display.



Depending on the vehicle and road conditions, the warning may not operate.

■ **Warning message**

If the following warning message is displayed on the multi-information display and the LTA indicator illuminates in orange, follow the appropriate troubleshooting procedure. Also, if a different warning message is displayed, follow the instructions displayed on the screen.

● “LTA Malfunction Visit Your Dealer”

The system may not be operating properly. Have the vehicle inspected by your Toyota dealer.

● “LTA Unavailable”

The system is temporarily canceled due to a malfunction in a sensor other than the front camera. Turn the LTA system off, wait for a little while, and then turn the LTA system back on.

● “LTA Unavailable at Current Speed”

The function cannot be used as the vehicle speed exceeds the LTA operation range. Drive slower.

■ **Customization**

Function settings can be changed. (→P. 101, 115)

APPENDIX C

Run Log

Subject Vehicle: **2021 Toyota Camry SE Sedan**

Test Date: **2/22/2021**

Driver: **J. Partridge**

Note: For Distance at Warning, positive values indicate inside the lane

Run	Lane Marking Type	Departure Direction	Valid Run?	Distance at Auditory Alert (ft)	Distance at Visual Alert (ft)	Pass/Fail	Notes
1	Dashed	Right	Y	0.63	0.38	Pass	
2			Y	0.74	0.49	Pass	
3			Y	0.95	0.66	Pass	
4			Y	0.81	0.58	Pass	
5			Y	0.84	0.61	Pass	
6			Y	0.43	0.22	Pass	
7			Y	0.87	0.63	Pass	
8	Dashed	Left	Y	0.74	0.47	Pass	
9			Y	0.84	0.60	Pass	
10			Y	0.83	0.64	Pass	
11			Y	1.14	0.95	Pass	
12			Y	1.18	0.94	Pass	
13			Y	1.19	0.86	Pass	
14			N				Yaw rate
15			Y	0.95	0.77	Pass	
16	Solid	Right	Y	0.92	0.72	Pass	
17			N				Yaw rate

Run	Lane Marking Type	Departure Direction	Valid Run?	Distance at Auditory Alert (ft)	Distance at Visual Alert (ft)	Pass/Fail	Notes
18	Solid	Right	Y	0.65	0.40	Pass	
19			N				Yaw rate
20			N				GPS fix type
21			Y	0.65	0.37	Pass	
22			N				Hit cone
23			Y	0.52	0.35	Pass	
24			N				Yaw rate
25			Y	0.83	0.58	Pass	
26			Y	0.69	0.48	Pass	
27			Y	0.66	0.42	Pass	
28			Solid	Left	Y	0.94	0.70
29	N						Yaw rate
30	N						Yaw rate
31	Y	0.73			0.57	Pass	
32	Y	0.70			0.49	Pass	
33	Y	0.17			-0.05	Pass	
34	Y	0.53			0.34	Pass	
35	Y	0.59			0.41	Pass	
36	Y	0.92			0.69	Pass	

Run	Lane Marking Type	Departure Direction	Valid Run?	Distance at Auditory Alert (ft)	Distance at Visual Alert (ft)	Pass/Fail	Notes
37	Botts	Left	N				Yaw rate
38			Y	0.88	0.68	Pass	
39			Y	0.04	-0.24	Pass	
40			Y	-0.03	-0.16	Pass	
41			N				Yaw rate
42			Y	0.18	-0.04	Pass	
43			Y	0.26	0.01	Pass	
44			Y	0.44	0.21	Pass	
45			Y	-0.17	-0.43	Pass	
46			Botts	Right	Y	0.48	0.23
47	Y	0.65			0.46	Pass	
48	Y	0.54			0.37	Pass	
49	Y	0.78			0.54	Pass	
50	Y	0.71			0.43	Pass	
51	N						Yaw rate
52	Y	0.60			0.37	Pass	
53	Y	0.31			0.11	Pass	

APPENDIX D

Time History Plots

LIST OF FIGURES

	Page
Figure D1. Example Time History for Lane Departure Warning Test, Passing.....	D-8
Figure D2. Example Time History for Lane Departure Warning Test, Failing, No Warning Issued.....	D-9
Figure D3. Example Time History for Lane Departure Warning Test, Invalid Run Due to Subject Vehicle Yaw Rate	D-10
Figure D4. Time History for Run 01, Dashed Line, Right Departure, Auditory Warning	D-11
Figure D5. Time History for Run 01, Dashed Line, Right Departure, Visual Warning	D-12
Figure D6. Time History for Run 02, Dashed Line, Right Departure, Auditory Warning	D-13
Figure D7. Time History for Run 02, Dashed Line, Right Departure, Visual Warning	D-14
Figure D8. Time History for Run 03, Dashed Line, Right Departure, Auditory Warning	D-15
Figure D9. Time History for Run 03, Dashed Line, Right Departure, Visual Warning	D-16
Figure D10. Time History for Run 04, Dashed Line, Right Departure, Auditory Warning	D-17
Figure D11. Time History for Run 04, Dashed Line, Right Departure, Visual Warning.....	D-18
Figure D12. Time History for Run 05, Dashed Line, Right Departure, Auditory Warning	D-19
Figure D13. Time History for Run 05, Dashed Line, Right Departure, Visual Warning.....	D-20
Figure D14. Time History for Run 06, Dashed Line, Right Departure, Auditory Warning	D-21
Figure D15. Time History for Run 06, Dashed Line, Right Departure, Visual Warning.....	D-22
Figure D16. Time History for Run 07, Dashed Line, Right Departure, Auditory Warning	D-23
Figure D17. Time History for Run 07, Dashed Line, Right Departure, Visual Warning.....	D-24
Figure D18. Time History for Run 08, Dashed Line, Left Departure, Auditory Warning.....	D-25
Figure D19. Time History for Run 08, Dashed Line, Left Departure, Visual Warning.....	D-26
Figure D20. Time History for Run 09, Dashed Line, Left Departure, Auditory Warning.....	D-27
Figure D21. Time History for Run 09, Dashed Line, Left Departure, Visual Warning.....	D-28
Figure D22. Time History for Run 10, Dashed Line, Left Departure, Auditory Warning.....	D-29
Figure D23. Time History for Run 10, Dashed Line, Left Departure, Visual Warning.....	D-30
Figure D24. Time History for Run 11, Dashed Line, Left Departure, Auditory Warning.....	D-31
Figure D25. Time History for Run 11, Dashed Line, Left Departure, Visual Warning.....	D-32
Figure D26. Time History for Run 12, Dashed Line, Left Departure, Auditory Warning.....	D-33
Figure D27. Time History for Run 12, Dashed Line, Left Departure, Visual Warning.....	D-34
Figure D28. Time History for Run 13, Dashed Line, Left Departure, Auditory Warning.....	D-35
Figure D29. Time History for Run 13, Dashed Line, Left Departure, Visual Warning.....	D-36
Figure D30. Time History for Run 15, Dashed Line, Left Departure, Auditory Warning.....	D-37
Figure D31. Time History for Run 15, Dashed Line, Left Departure, Visual Warning.....	D-38
Figure D32. Time History for Run 16, Solid Line, Right Departure, Auditory Warning.....	D-39
Figure D33. Time History for Run 16, Solid Line, Right Departure, Visual Warning.....	D-40
Figure D34. Time History for Run 18, Solid Line, Right Departure, Auditory Warning.....	D-41
Figure D35. Time History for Run 18, Solid Line, Right Departure, Visual Warning.....	D-42
Figure D36. Time History for Run 21, Solid Line, Right Departure, Auditory Warning.....	D-43
Figure D37. Time History for Run 21, Solid Line, Right Departure, Visual Warning.....	D-44
Figure D38. Time History for Run 23, Solid Line, Right Departure, Auditory Warning.....	D-45

Figure D39.	Time History for Run 23, Solid Line, Right Departure, Visual Warning	D-46
Figure D40.	Time History for Run 25, Solid Line, Right Departure, Auditory Warning.....	D-47
Figure D41.	Time History for Run 25, Solid Line, Right Departure, Visual Warning	D-48
Figure D42.	Time History for Run 26, Solid Line, Right Departure, Auditory Warning.....	D-49
Figure D43.	Time History for Run 26, Solid Line, Right Departure, Visual Warning	D-50
Figure D44.	Time History for Run 27, Solid Line, Right Departure, Auditory Warning.....	D-51
Figure D45.	Time History for Run 27, Solid Line, Right Departure, Visual Warning	D-52
Figure D46.	Time History for Run 28, Solid Line, Left Departure, Auditory Warning	D-53
Figure D47.	Time History for Run 28, Solid Line, Left Departure, Visual Warning	D-54
Figure D48.	Time History for Run 31, Solid Line, Left Departure, Auditory Warning	D-55
Figure D49.	Time History for Run 31, Solid Line, Left Departure, Visual Warning	D-56
Figure D50.	Time History for Run 32, Solid Line, Left Departure, Auditory Warning	D-57
Figure D51.	Time History for Run 32, Solid Line, Left Departure, Visual Warning	D-58
Figure D52.	Time History for Run 33, Solid Line, Left Departure, Auditory Warning	D-59
Figure D53.	Time History for Run 33, Solid Line, Left Departure, Visual Warning	D-60
Figure D54.	Time History for Run 34, Solid Line, Left Departure, Auditory Warning	D-61
Figure D55.	Time History for Run 34, Solid Line, Left Departure, Visual Warning	D-62
Figure D56.	Time History for Run 35, Solid Line, Left Departure, Auditory Warning	D-63
Figure D57.	Time History for Run 35, Solid Line, Left Departure, Visual Warning	D-64
Figure D58.	Time History for Run 36, Solid Line, Left Departure, Auditory Warning	D-65
Figure D59.	Time History for Run 36, Solid Line, Left Departure, Visual Warning	D-66
Figure D60.	Time History for Run 38, Botts Dots, Left Departure, Auditory Warning	D-67
Figure D61.	Time History for Run 38, Botts Dots, Left Departure, Visual Warning	D-68
Figure D62.	Time History for Run 39, Botts Dots, Left Departure, Auditory Warning	D-69
Figure D63.	Time History for Run 39, Botts Dots, Left Departure, Visual Warning	D-70
Figure D64.	Time History for Run 40, Botts Dots, Left Departure, Auditory Warning	D-71
Figure D65.	Time History for Run 40, Botts Dots, Left Departure, Visual Warning	D-72
Figure D66.	Time History for Run 42, Botts Dots, Left Departure, Auditory Warning	D-73
Figure D67.	Time History for Run 42, Botts Dots, Left Departure, Visual Warning	D-74
Figure D68.	Time History for Run 43, Botts Dots, Left Departure, Auditory Warning	D-75
Figure D69.	Time History for Run 43, Botts Dots, Left Departure, Visual Warning	D-76
Figure D70.	Time History for Run 44, Botts Dots, Left Departure, Auditory Warning	D-77
Figure D71.	Time History for Run 44, Botts Dots, Left Departure, Visual Warning	D-78
Figure D72.	Time History for Run 45, Botts Dots, Left Departure, Auditory Warning	D-79
Figure D73.	Time History for Run 45, Botts Dots, Left Departure, Visual Warning	D-80
Figure D74.	Time History for Run 46, Botts Dots, Right Departure, Auditory Warning.....	D-81
Figure D75.	Time History for Run 46, Botts Dots, Right Departure, Visual Warning	D-82
Figure D76.	Time History for Run 47, Botts Dots, Right Departure, Auditory Warning.....	D-83
Figure D77.	Time History for Run 47, Botts Dots, Right Departure, Visual Warning	D-84
Figure D78.	Time History for Run 48, Botts Dots, Right Departure, Auditory Warning.....	D-85
Figure D79.	Time History for Run 48, Botts Dots, Right Departure, Visual Warning	D-86
Figure D80.	Time History for Run 49, Botts Dots, Right Departure, Auditory Warning.....	D-87
Figure D81.	Time History for Run 49, Botts Dots, Right Departure, Visual Warning	D-88

Figure D82. Time History for Run 50, Botts Dots, Right Departure, Auditory Warning	D-89
Figure D83. Time History for Run 50, Botts Dots, Right Departure, Visual Warning	D-90
Figure D84. Time History for Run 52, Botts Dots, Right Departure, Auditory Warning	D-91
Figure D85. Time History for Run 52, Botts Dots, Right Departure, Visual Warning	D-92
Figure D86. Time History for Run 53, Botts Dots, Right Departure, Auditory Warning	D-93
Figure D87. Time History for Run 53, Botts Dots, Right Departure, Visual Warning	D-94

Description of Time History Plots

A set of time history plots is provided for each valid run in the test series. Each set of plots comprises time varying data from the Subject Vehicle, as well as pass/fail envelopes and thresholds. The following is a description of data types shown in the time history plots, as well as a description of the color code for data envelopes.

Time History Plot Description

Time history figures include the following sub-plots:

- Warning – Indicates timing of warning issued by LDW system. Depending on the type of LDW alert or instrumentation used to measure the alert, this can be any of the following:
 - Filtered and rectified sound signal
 - Filtered and rectified acceleration (e.g., steering wheel vibration)
 - Light sensor signal
 - Discrete on/off value
- Speed (mph) – Speed of the Subject Vehicle
- Yaw Rate (deg/sec) – Yaw rate of the Subject Vehicle
- Distance to Lane Edge (ft) – Lateral distance (in lane coordinates) from the outer front tire bulge to the inside edge of the lane marking of interest for a given test (a positive value indicates the vehicle is completely within the lane while a negative value indicates that the outer front tire bulge has crossed over the inner lane marking edge). The distance to the lane edge at the moment the LDW alert is issued, is displayed to the right of subplot.
- Lateral Lane Velocity (ft/sec) – Lateral velocity (in lane coordinates) of the outer front tire bulge
- Bird's Eye View – Indicates the position of the Subject Vehicle with respect to the lane marking of interest for a given test. Green rectangles represent the Subject Vehicle's position at approximately 2 second intervals, while the yellow rectangle indicates the position of the Subject Vehicle at the time of LDW warning issuance.

Envelopes and Thresholds

Each of the time history plot figures can contain either green or yellow envelopes and/or black threshold lines. These envelopes and thresholds are used to programmatically and visually determine the validity of a given test run. Envelope and threshold exceedances are indicated with either red shading or red asterisks, and red text is placed to the right side of the plot indicating the type of exceedance.

Green envelopes indicate that the time-varying data should not exceed the envelope boundaries at any time within the envelope. Exceedances of a green envelope are indicated by red shading in the area between the measured time-varying data and the envelope boundaries.

Yellow envelopes indicate that the time-varying data should not exceed the envelope only at the right end. Exceedances at the right extent of a yellow envelope are indicated by red asterisks. Data within the boundaries at the right extent of a yellow envelope are indicated by green circles.

For the warning plot, a dashed black threshold line indicates the threshold used to determine the onset of the LDW alert. The alert is considered on the first time the alert signal crosses this threshold line.

Color Codes

Color codes have been adopted to easily identify the types of data, envelopes, and thresholds used in the plots.

Color codes can be broken into three categories:

1. Validation envelopes and thresholds
 1. Validation envelopes and thresholds
 2. Instantaneous samplings
 3. Text
1. Validation envelope and threshold color codes:
 - Green envelope = time varying data must be within the envelope at all times in order to be valid
 - Yellow envelope = time varying data must be within limits at right end
 - Black threshold (Solid) = time varying data must not exceed this threshold in order to be valid
 - Black threshold (Dashed) = for reference only – this can include warning level thresholds which are used to determine the timing of the alert
2. Instantaneous sampling color codes:
 - Green circle = passing or valid value at a given moment in time
 - Red asterisk = failing or invalid value at a given moment in time

3. Text color codes:

- Green = passing or valid value
- Red = failing or invalid value

Other Notations

- NG – Indicates that the value for that variable was outside of bounds and therefore “No Good”.
- No Wng – No warning was detected.

The minimum (worst) GPS fix type is displayed in the lower right corner of each page. The only valid fix type is RTK fixed (displayed in green). If the fix type during any portion of the test was anything other than RTK fixed, then “RTK Fixed OR LESS!!” is displayed in red.

Examples of time history plots (including passing, failing and invalid runs) are shown in Figure D1 through Figure D3. Actual time history data plots for the vehicle under consideration are provided subsequently.

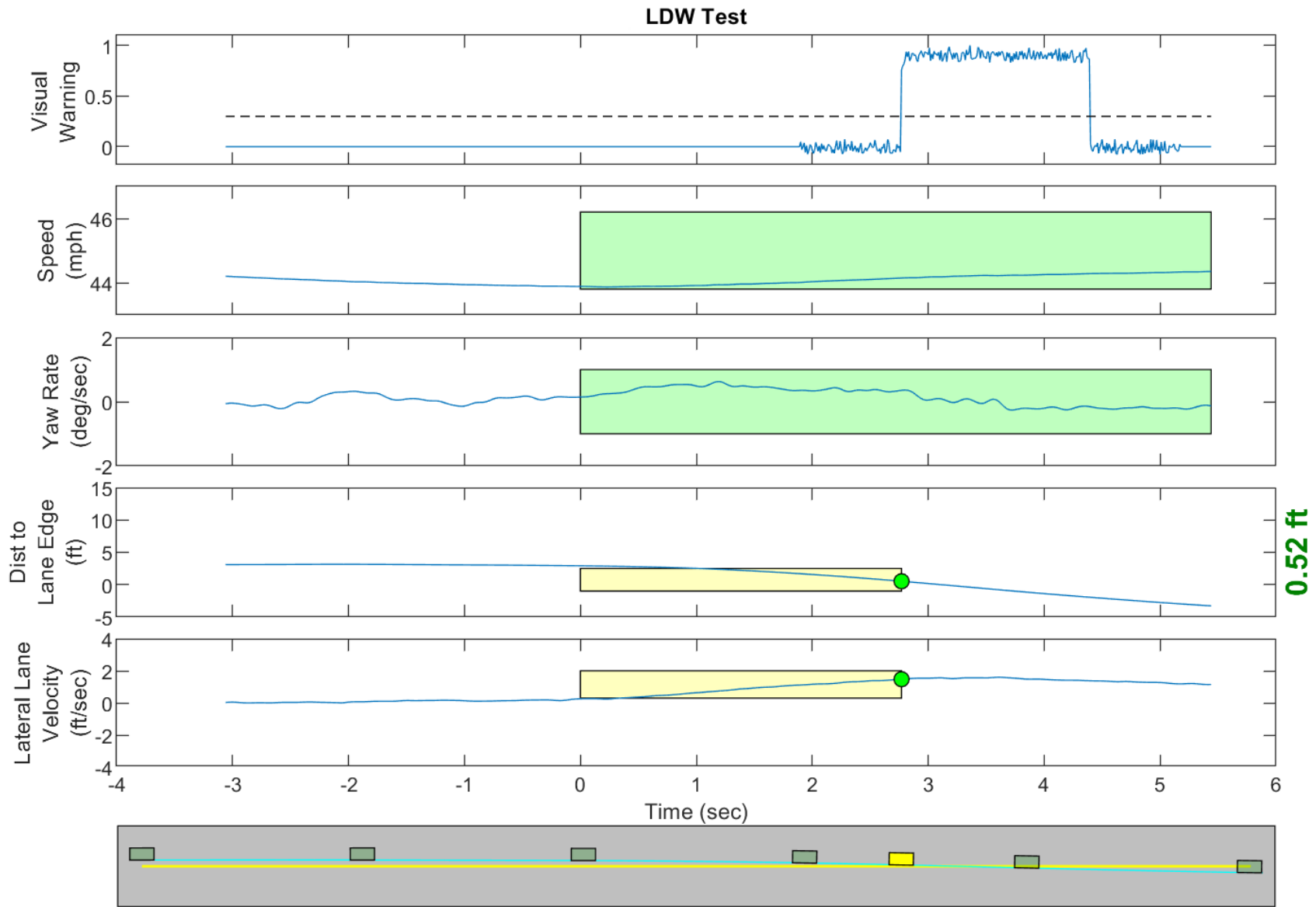

GPS Fix Type: RTK Fixed

Figure D1. Example Time History for Lane Departure Warning Test, Passing

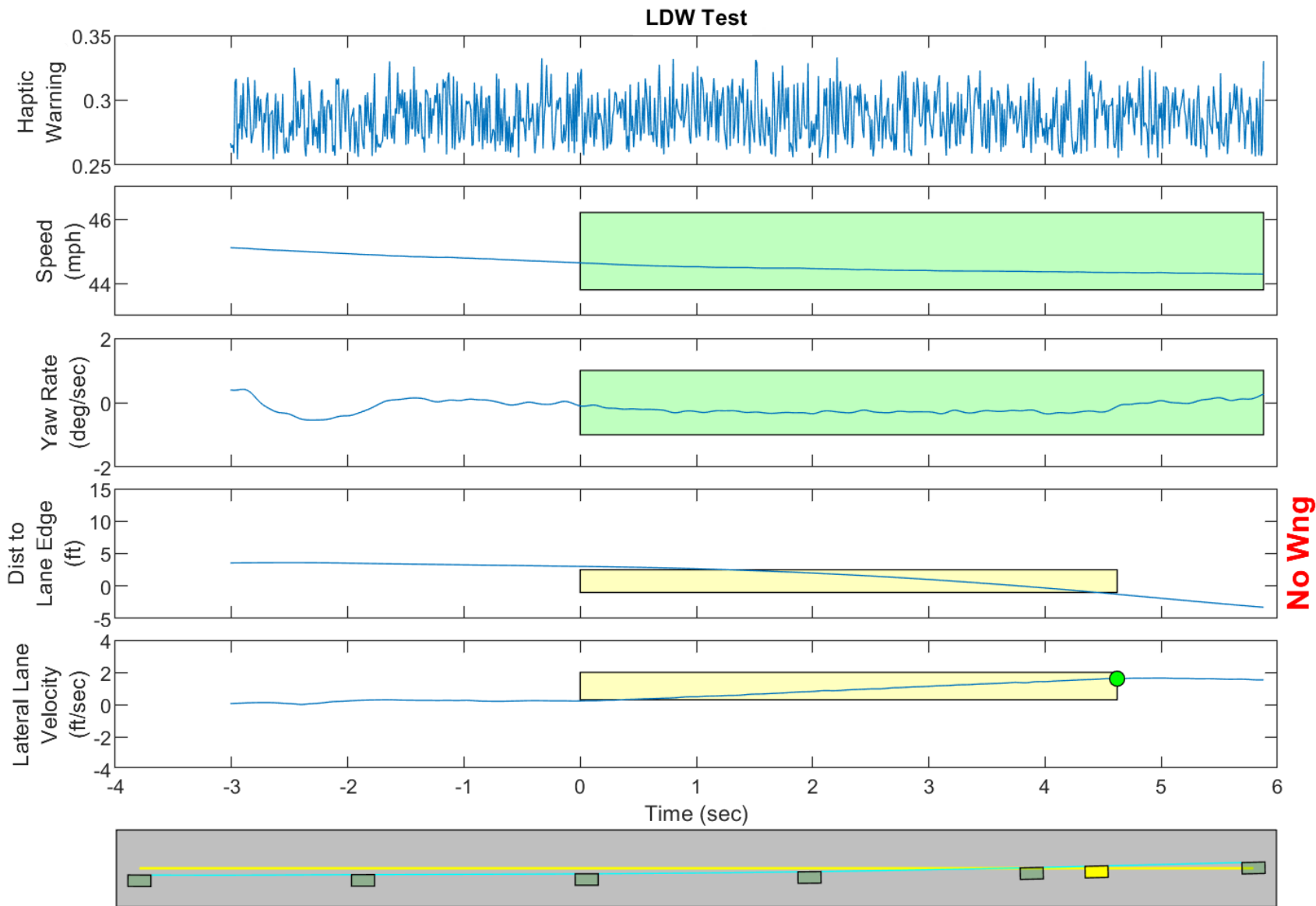

GPS Fix Type: RTK Fixed

Figure D2. Example Time History for Lane Departure Warning Test, Failing, No Warning Issued

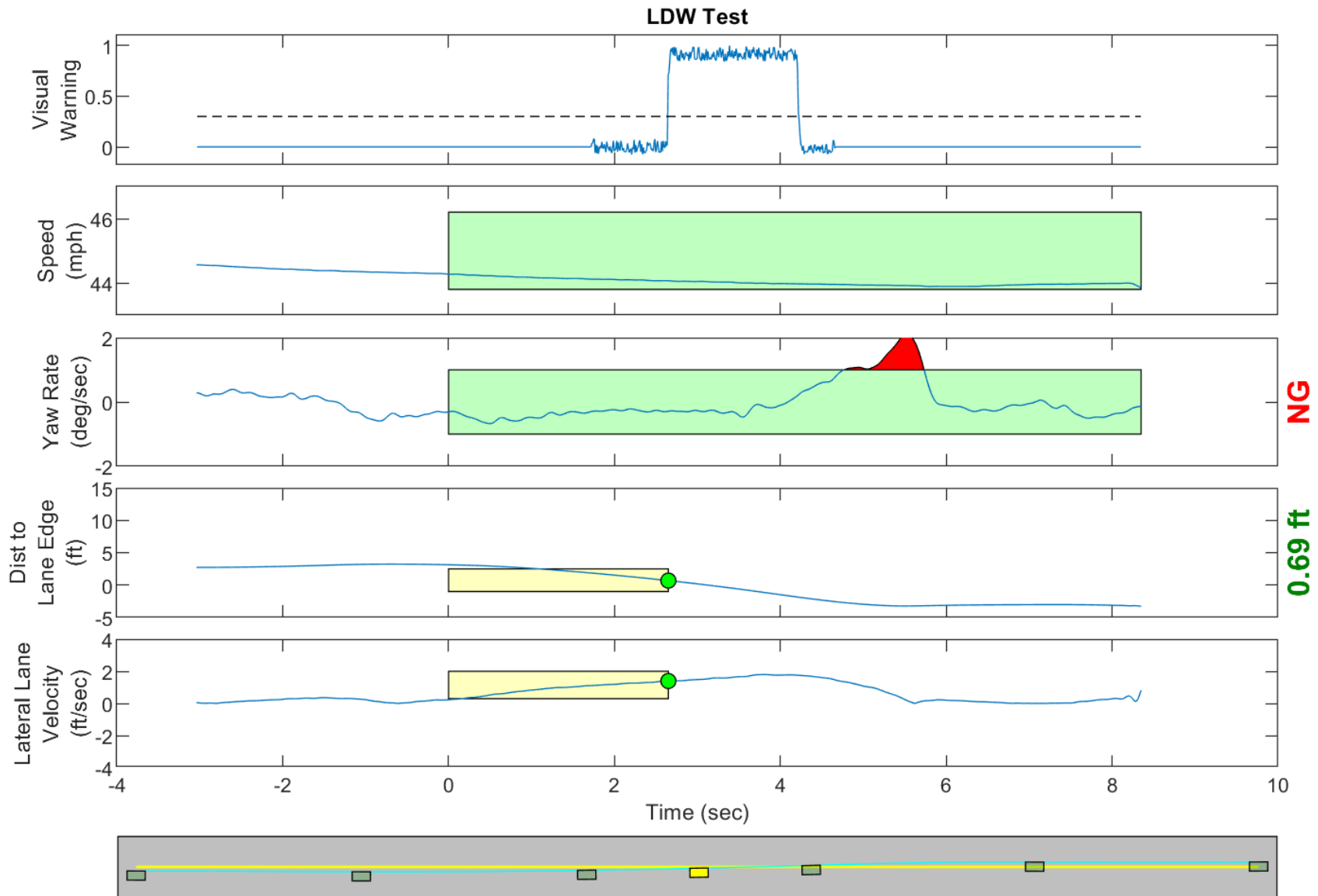

GPS Fix Type: RTK Fixed

Figure D3. Example Time History for Lane Departure Warning Test, Invalid Run Due to Subject Vehicle Yaw Rate

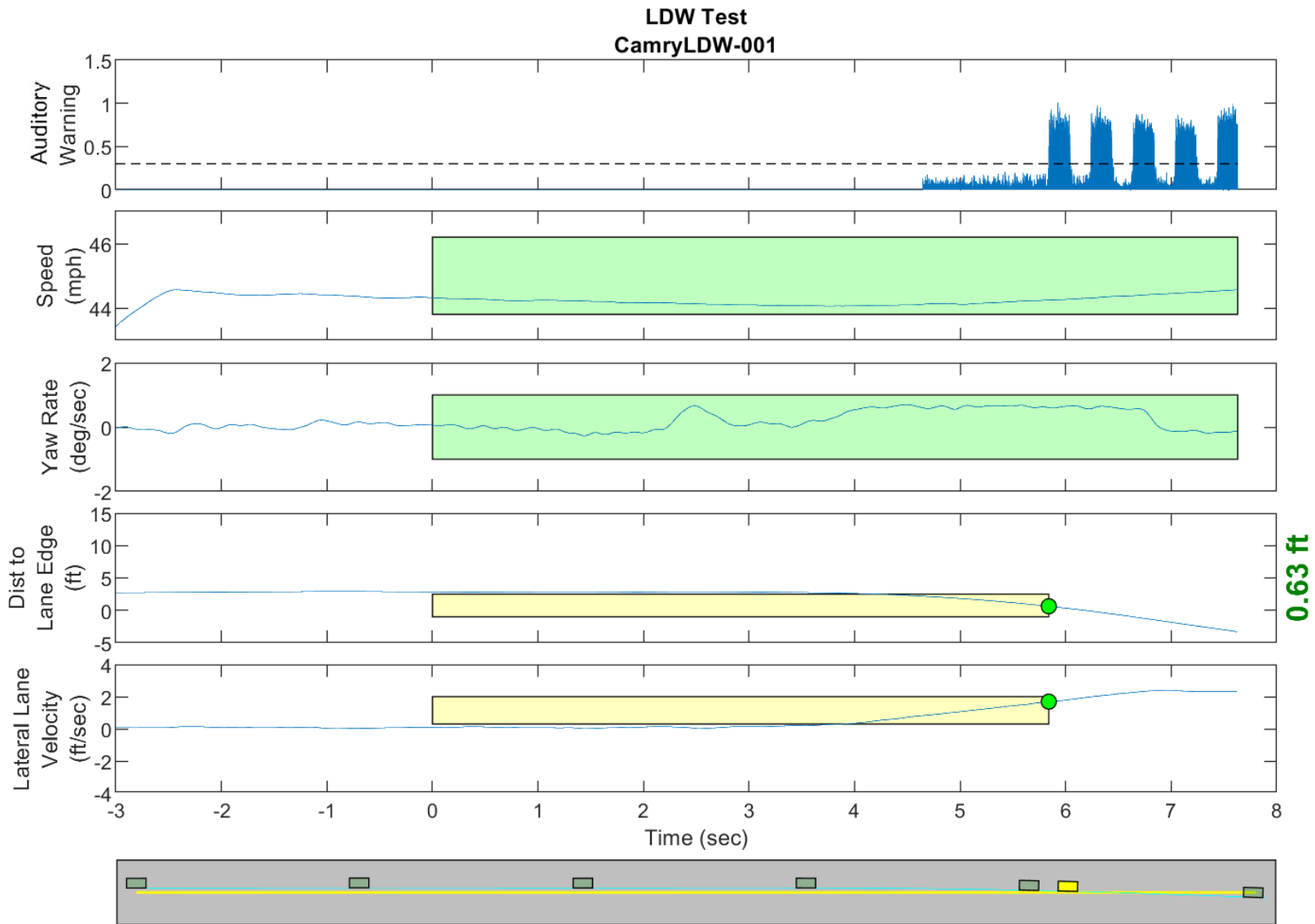

GPS Fix Type: RTK Fixed

Figure D4. Time History for Run 01, Dashed Line, Right Departure, Auditory Warning

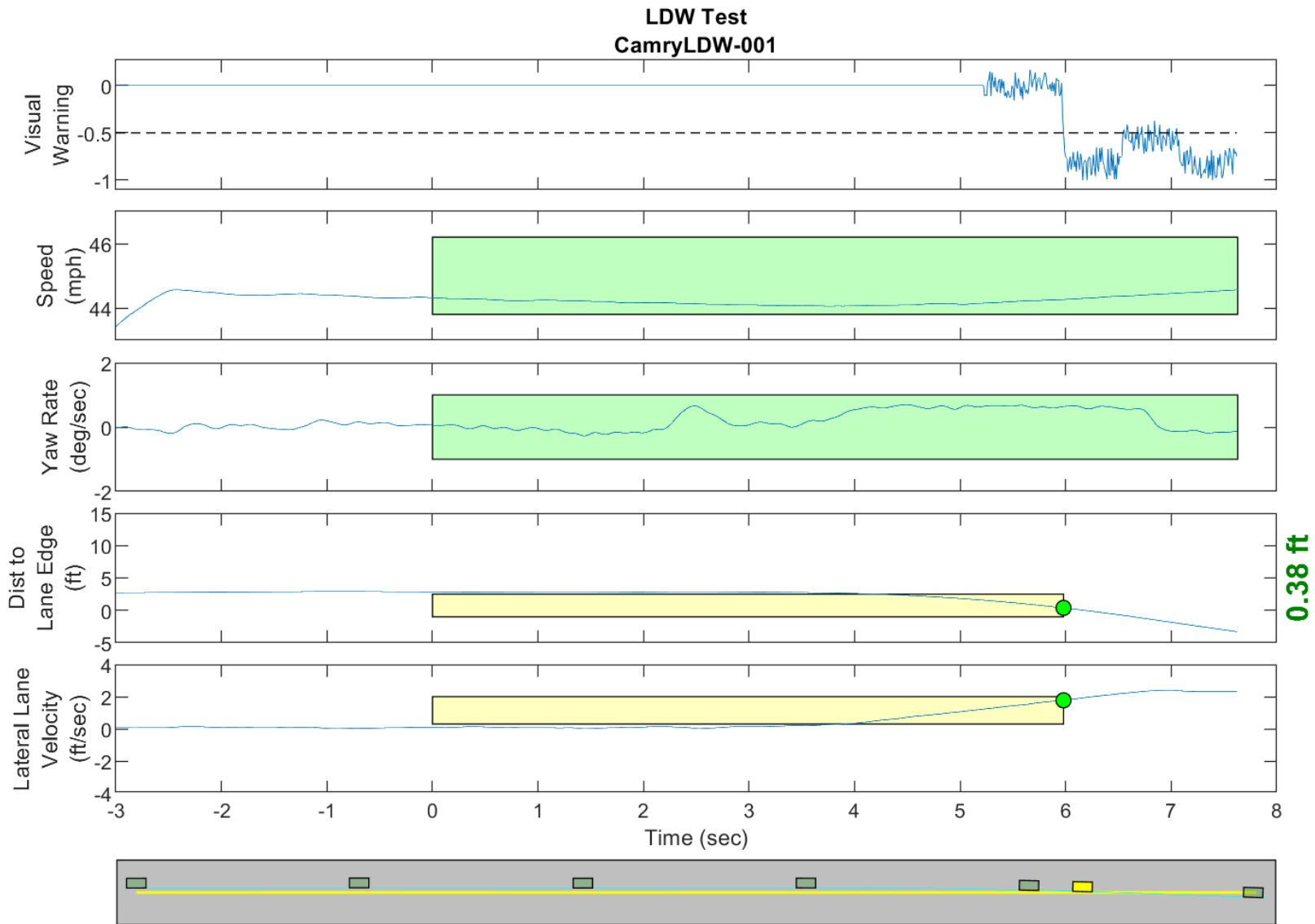

GPS Fix Type: RTK Fixed

Figure D5. Time History for Run 01, Dashed Line, Right Departure, Visual Warning

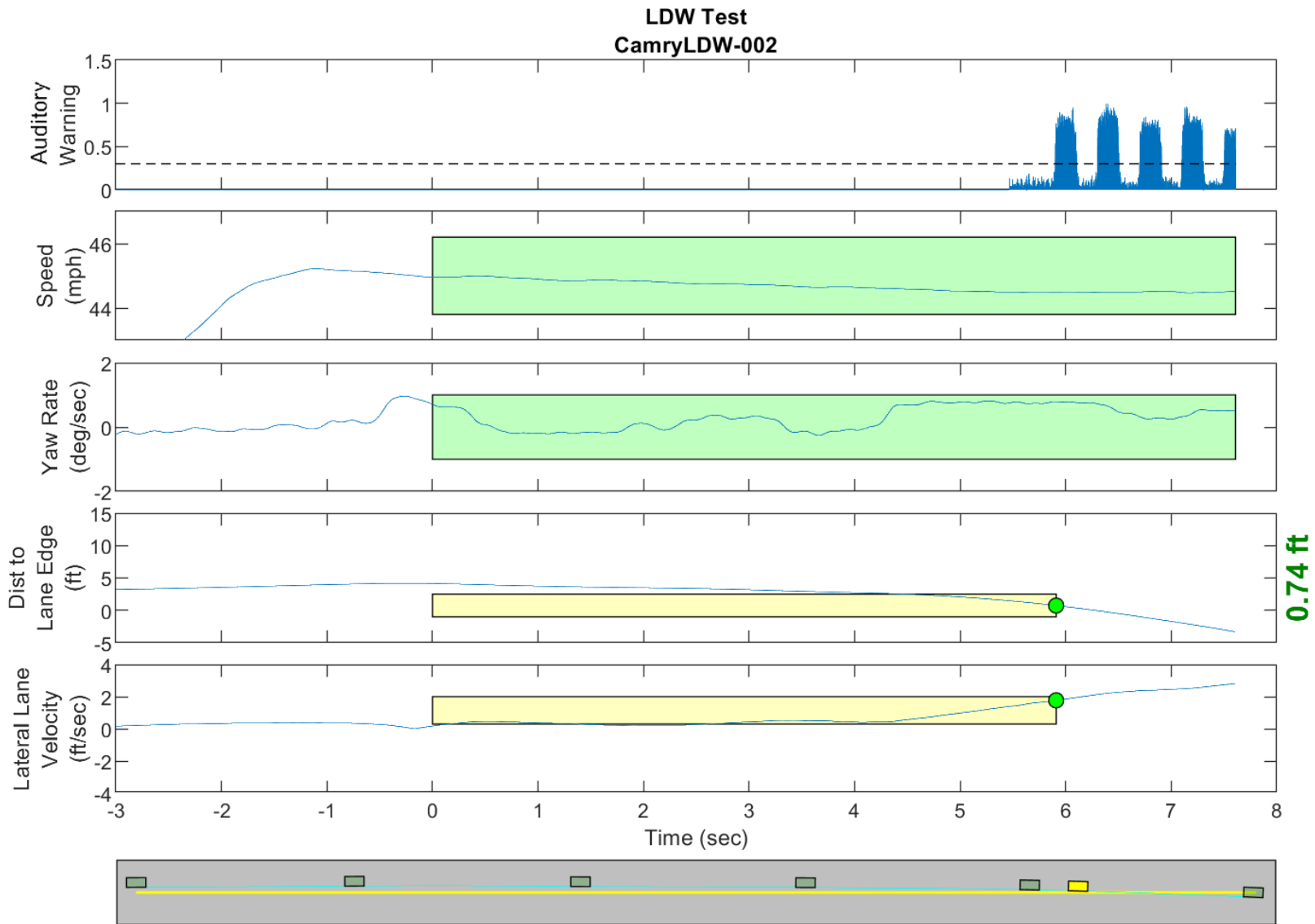

GPS Fix Type: RTK Fixed

Figure D6. Time History for Run 02, Dashed Line, Right Departure, Auditory Warning

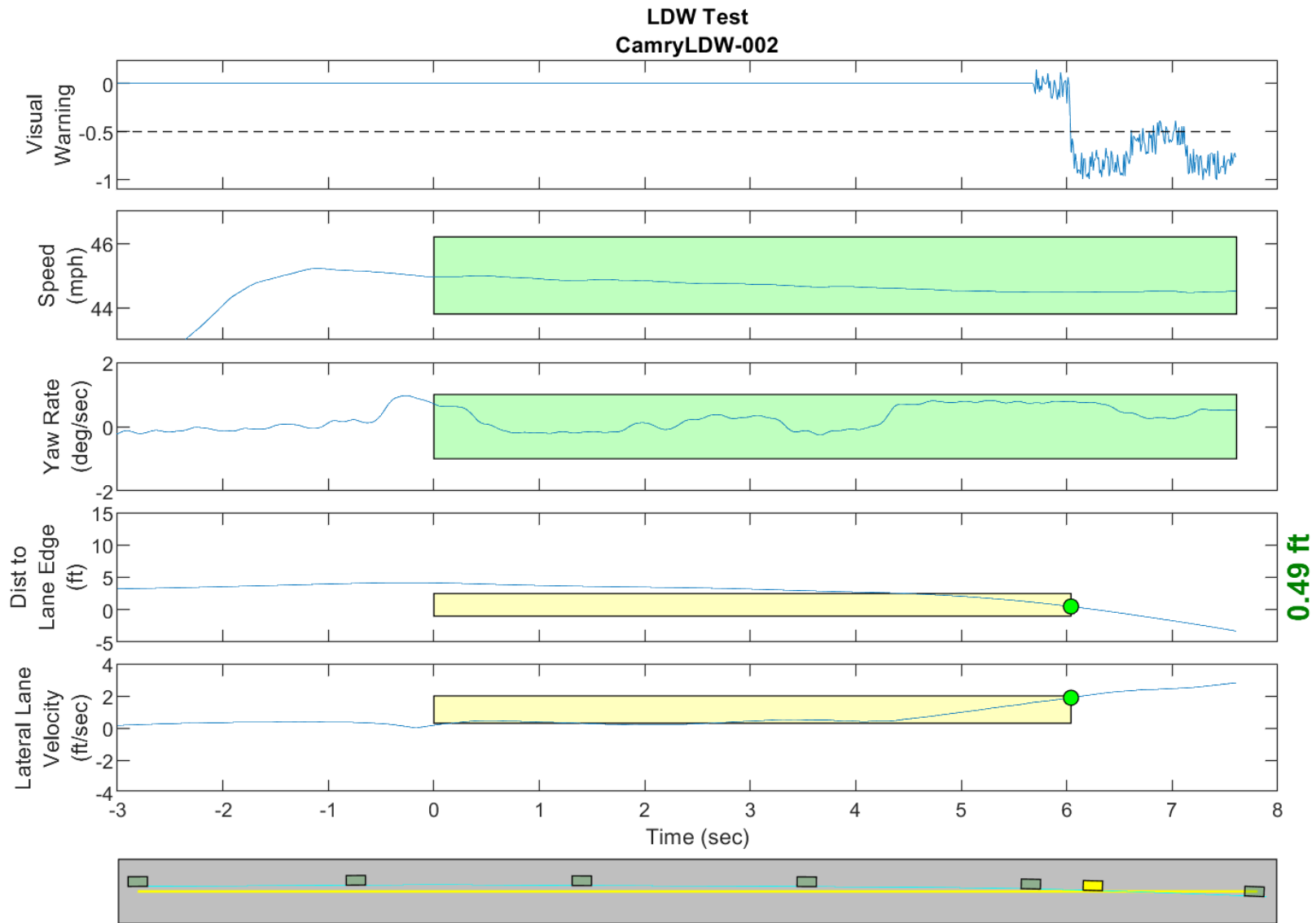

GPS Fix Type: RTK Fixed

Figure D7. Time History for Run 02, Dashed Line, Right Departure, Visual Warning

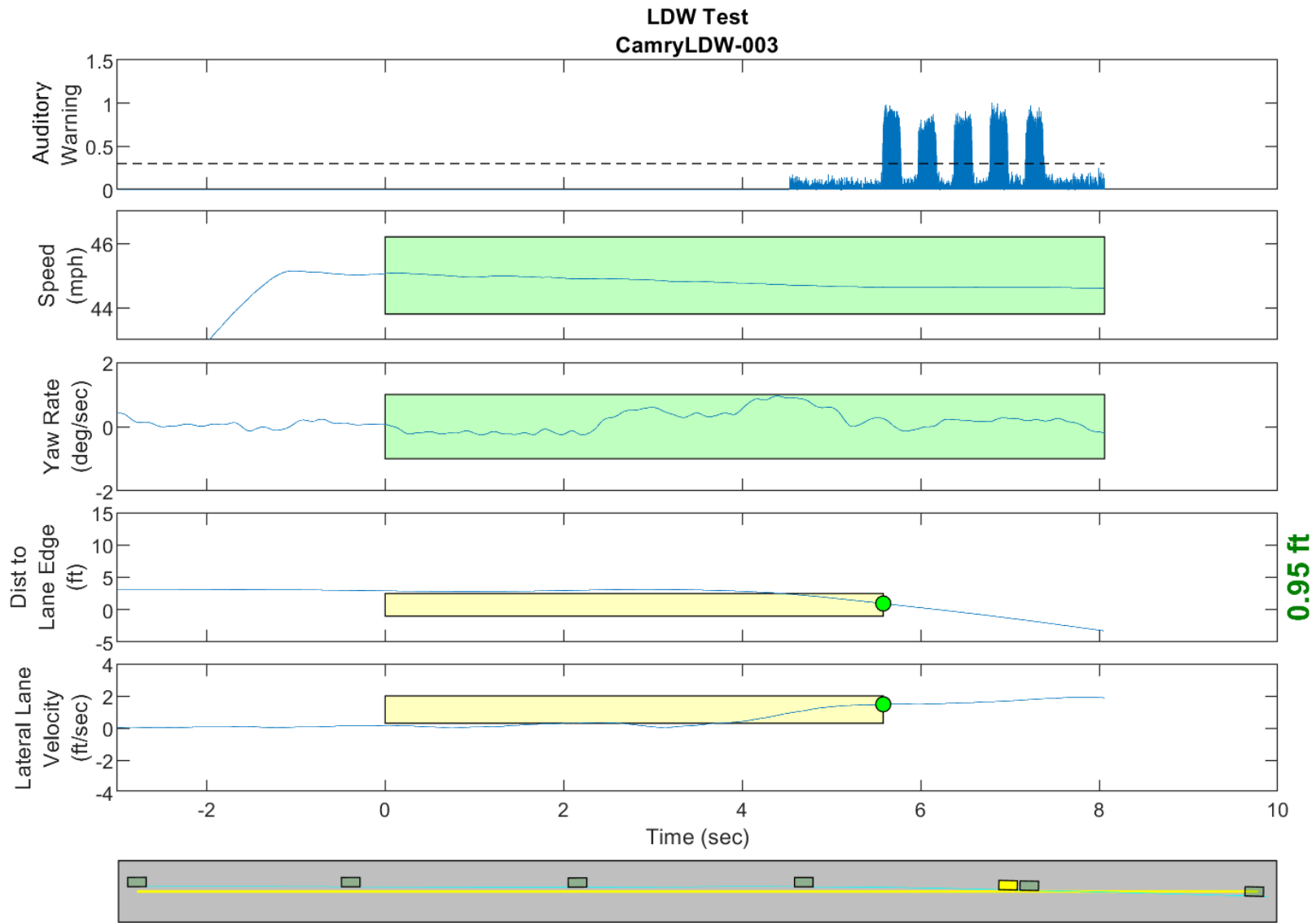

GPS Fix Type: RTK Fixed

Figure D8. Time History for Run 03, Dashed Line, Right Departure, Auditory Warning

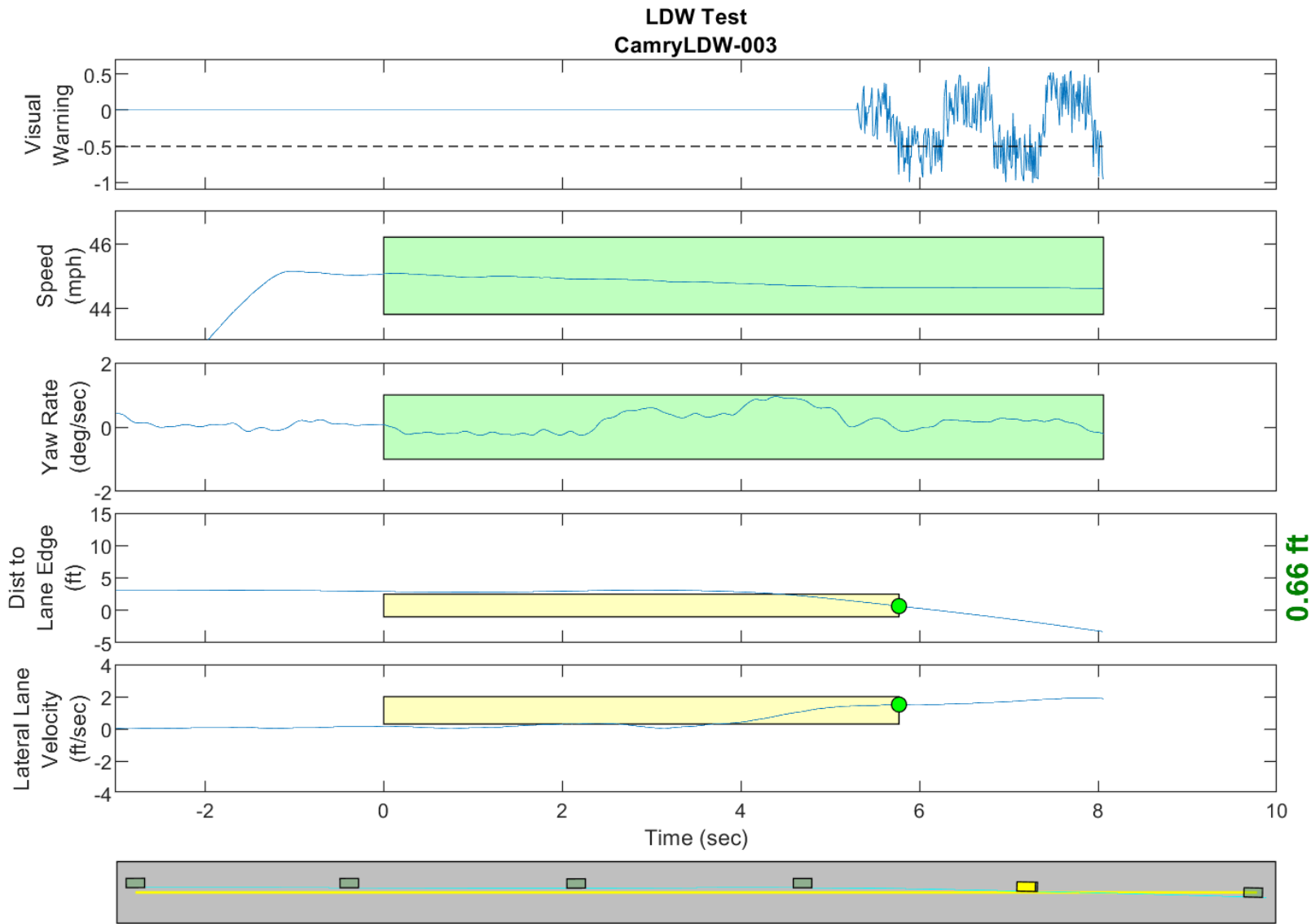

GPS Fix Type: RTK Fixed

Figure D9. Time History for Run 03, Dashed Line, Right Departure, Visual Warning

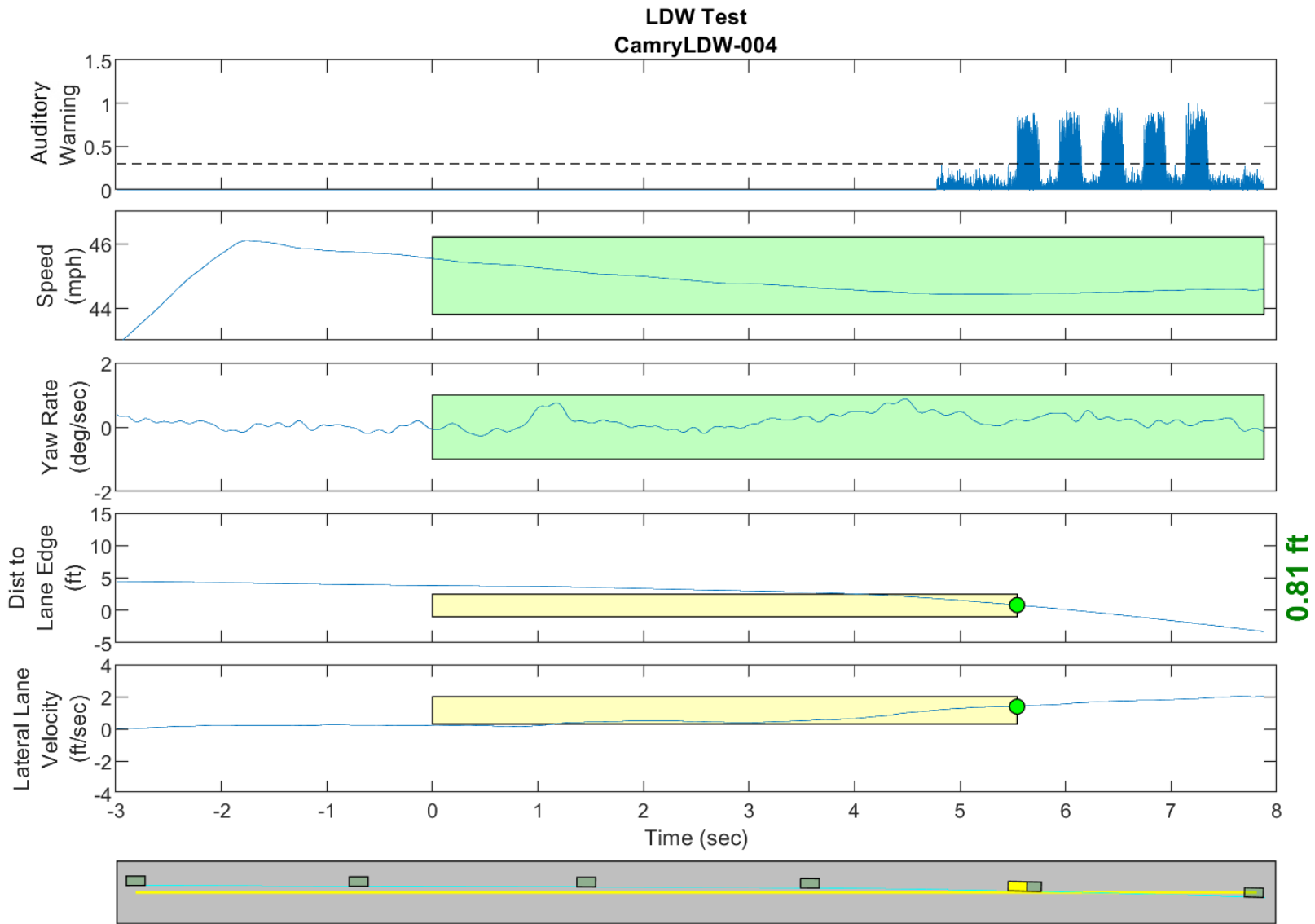

GPS Fix Type: RTK Fixed

Figure D10. Time History for Run 04, Dashed Line, Right Departure, Auditory Warning

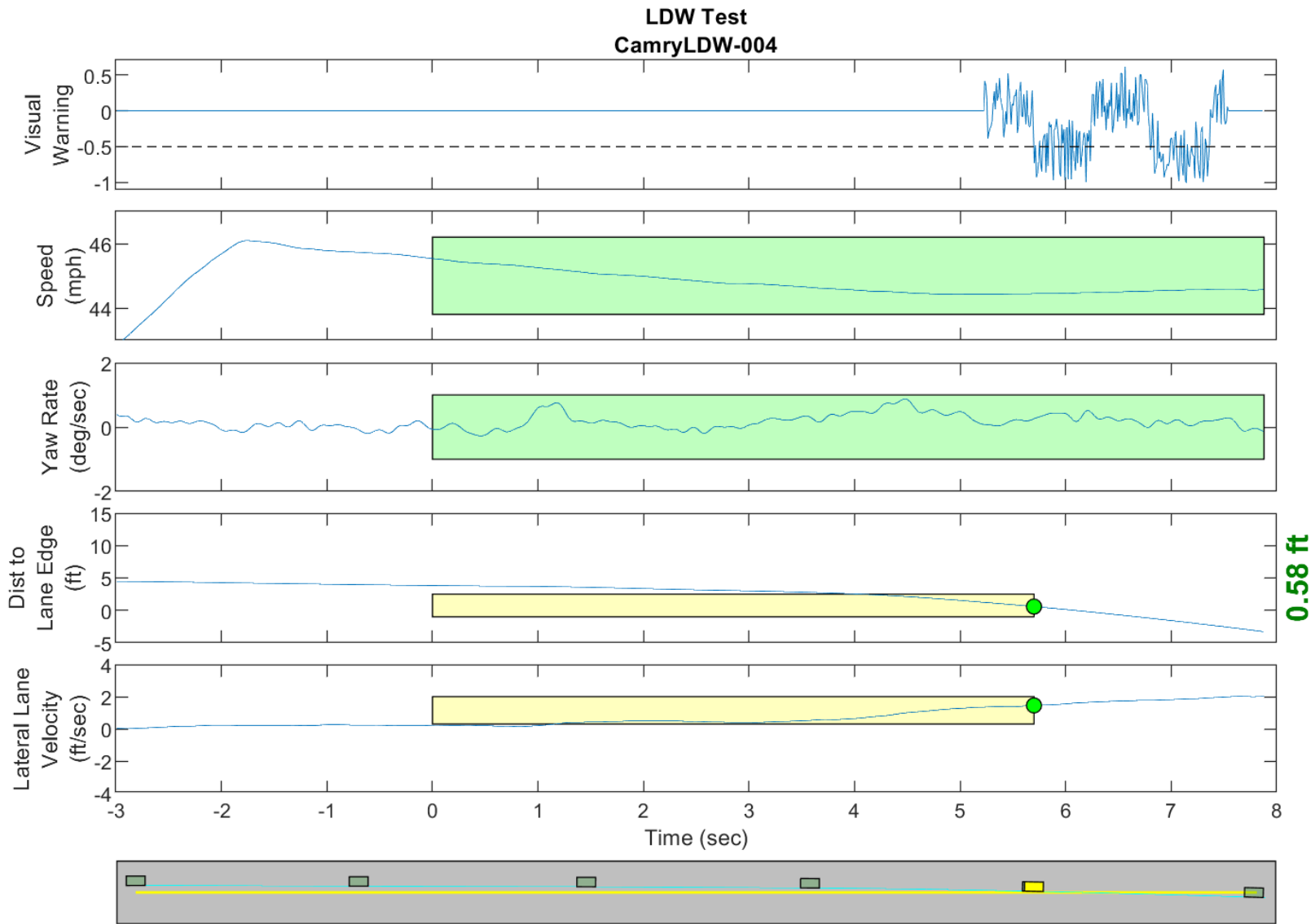

GPS Fix Type: RTK Fixed

Figure D11. Time History for Run 04, Dashed Line, Right Departure, Visual Warning

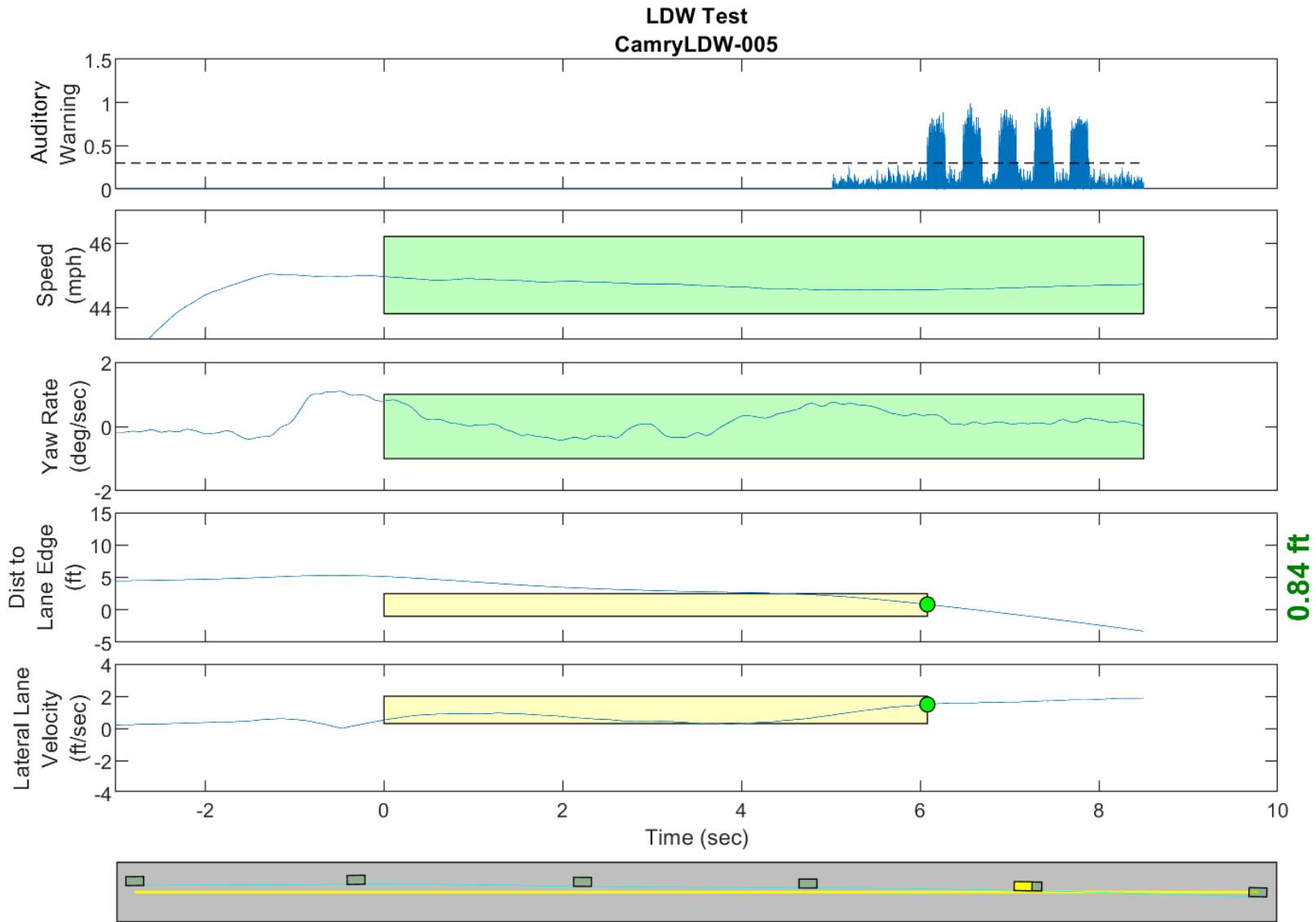

GPS Fix Type: RTK Fixed

Figure D12. Time History for Run 05, Dashed Line, Right Departure, Auditory Warning

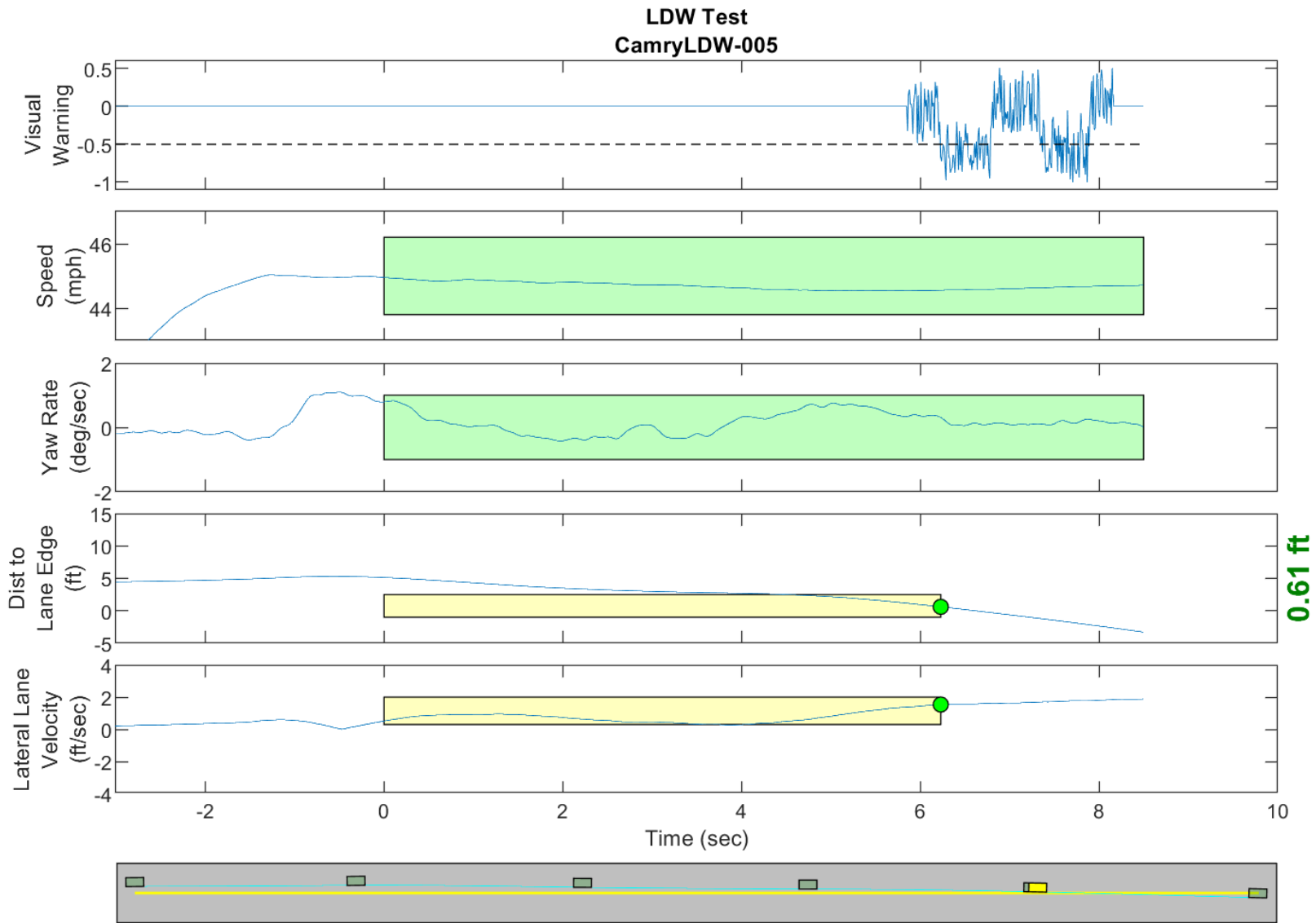

GPS Fix Type: RTK Fixed

Figure D13. Time History for Run 05, Dashed Line, Right Departure, Visual Warning

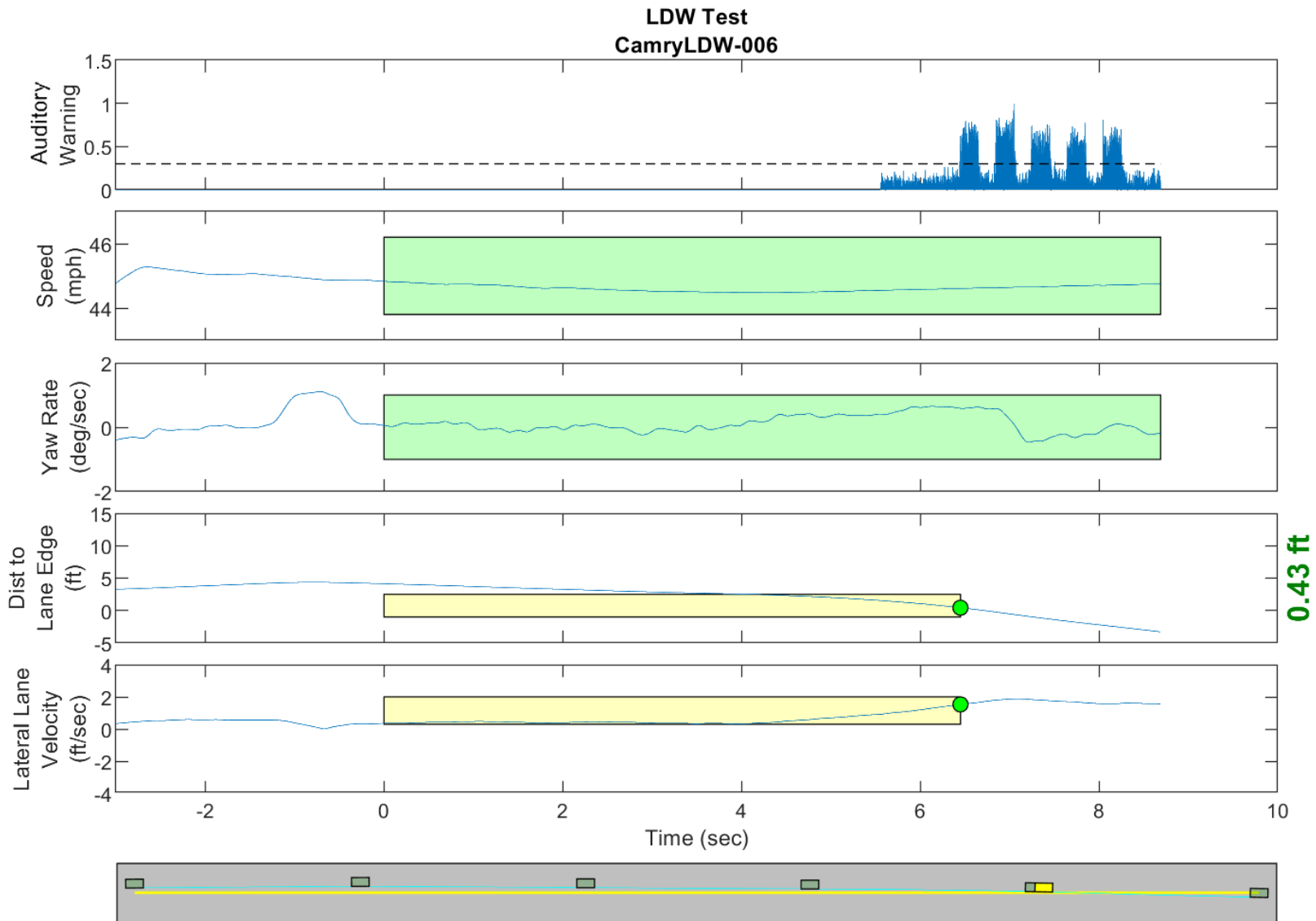

GPS Fix Type: RTK Fixed

Figure D14. Time History for Run 06, Dashed Line, Right Departure, Auditory Warning

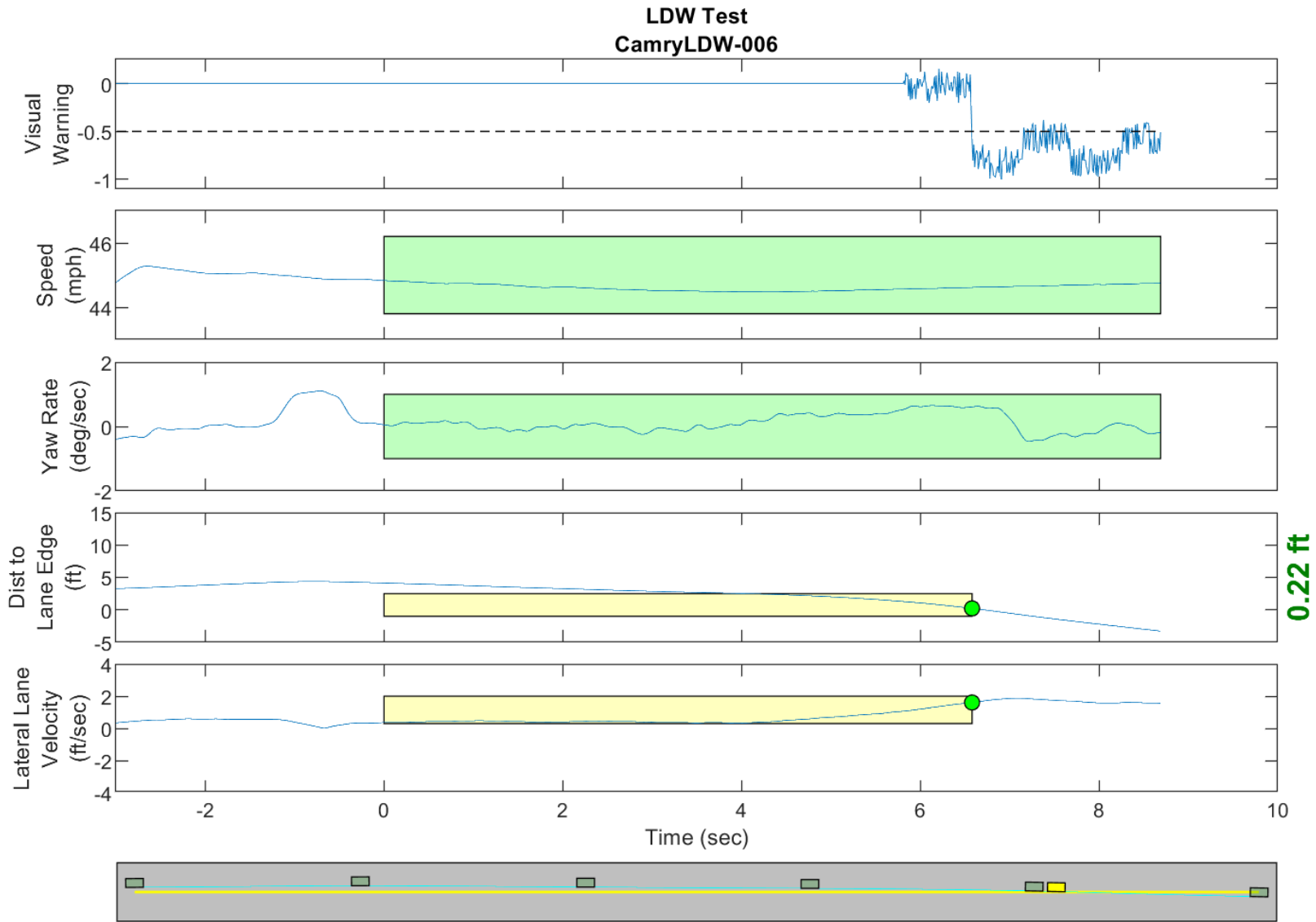

GPS Fix Type: RTK Fixed

Figure D15. Time History for Run 06, Dashed Line, Right Departure, Visual Warning

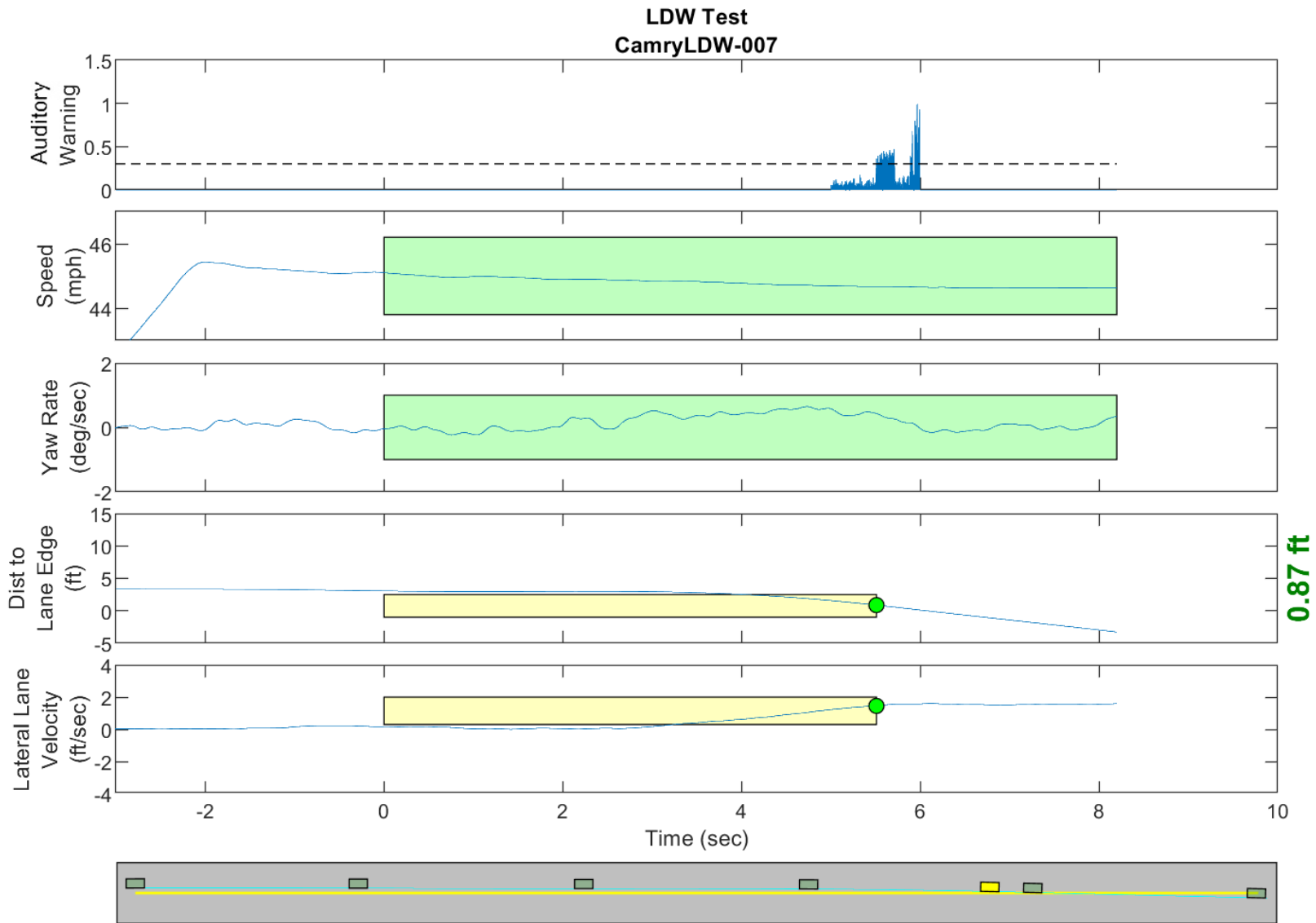

GPS Fix Type: RTK Fixed

Figure D16. Time History for Run 07, Dashed Line, Right Departure, Auditory Warning

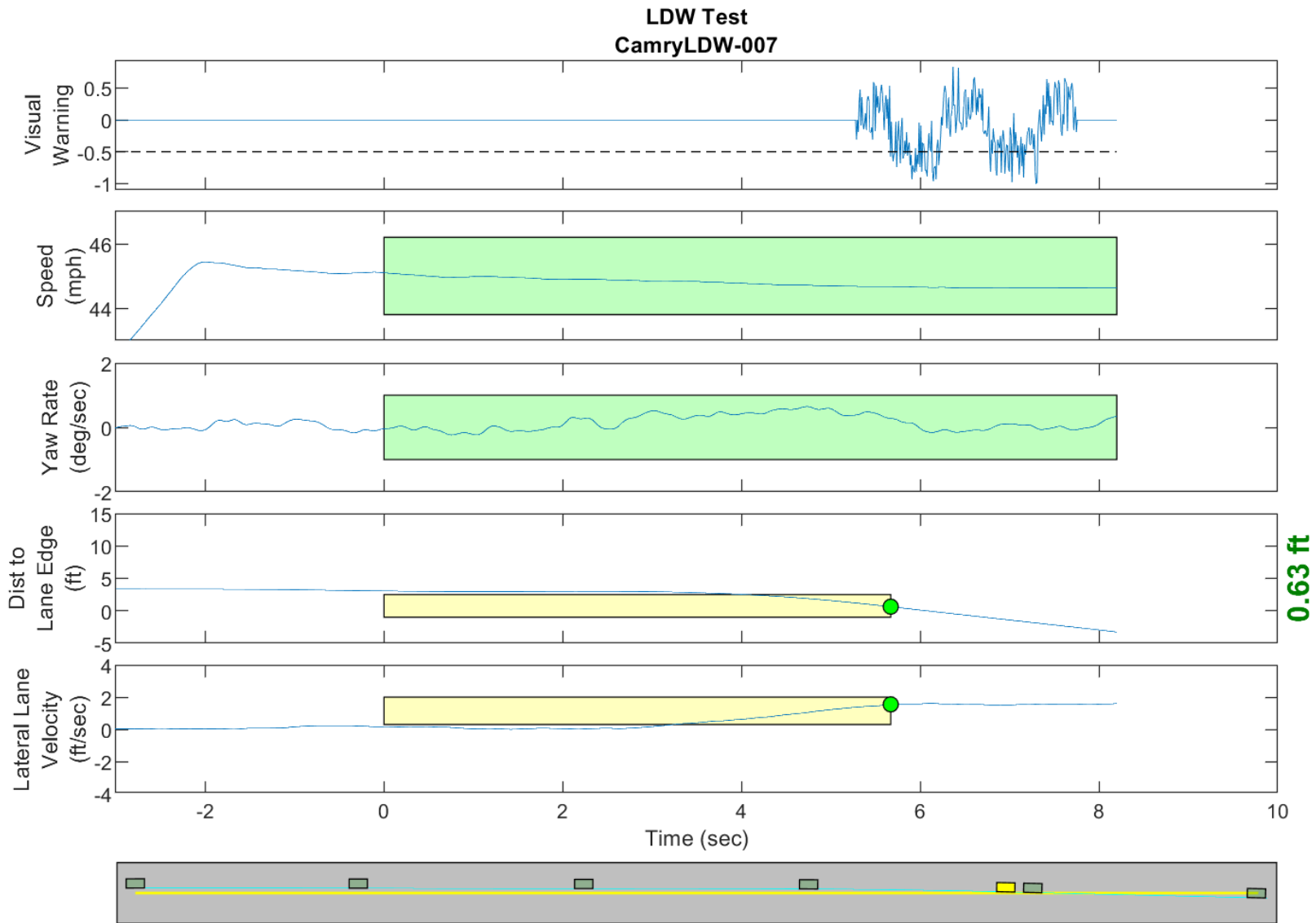

GPS Fix Type: RTK Fixed

Figure D17. Time History for Run 07, Dashed Line, Right Departure, Visual Warning

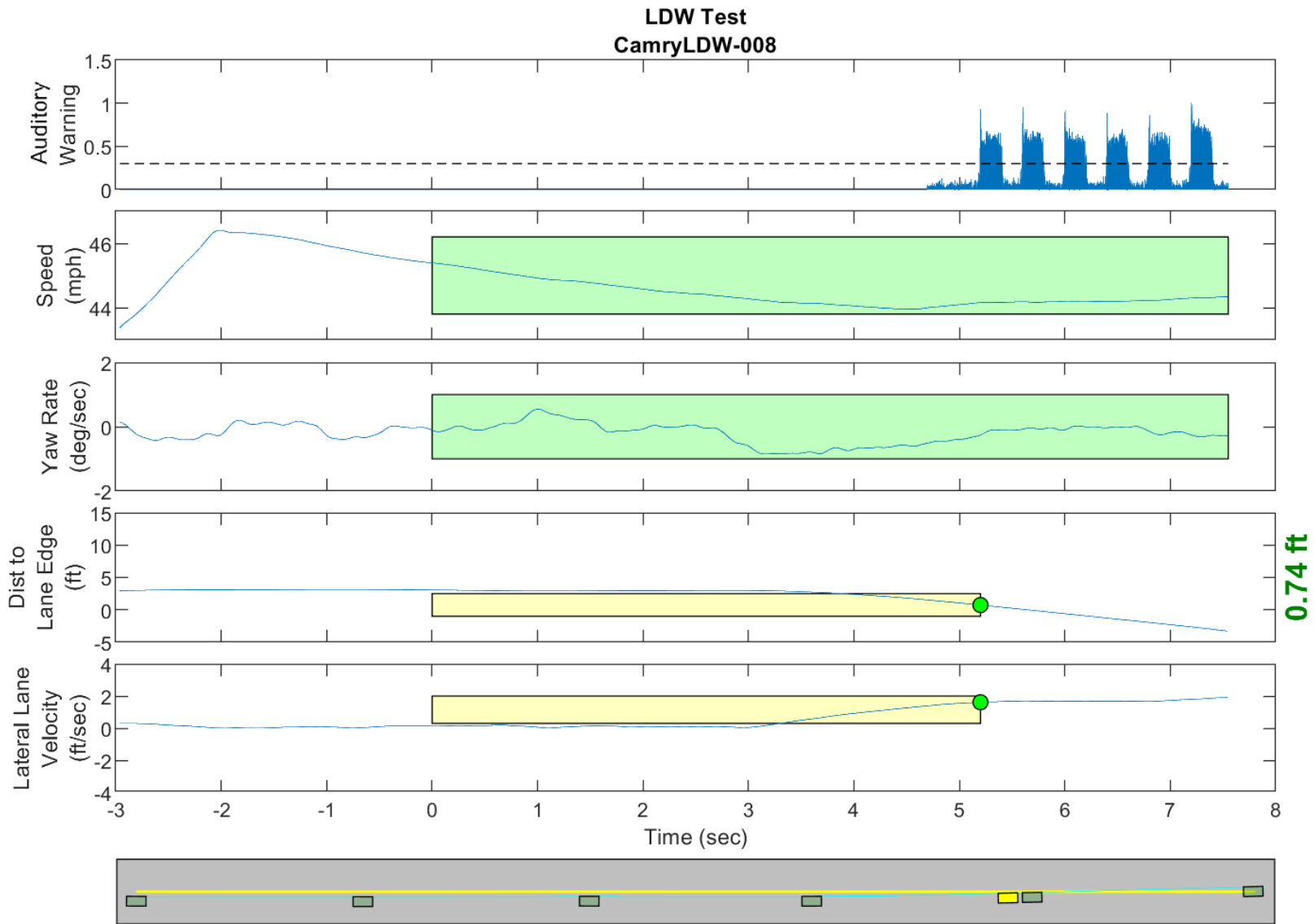

GPS Fix Type: RTK Fixed

Figure D18. Time History for Run 08, Dashed Line, Left Departure, Auditory Warning

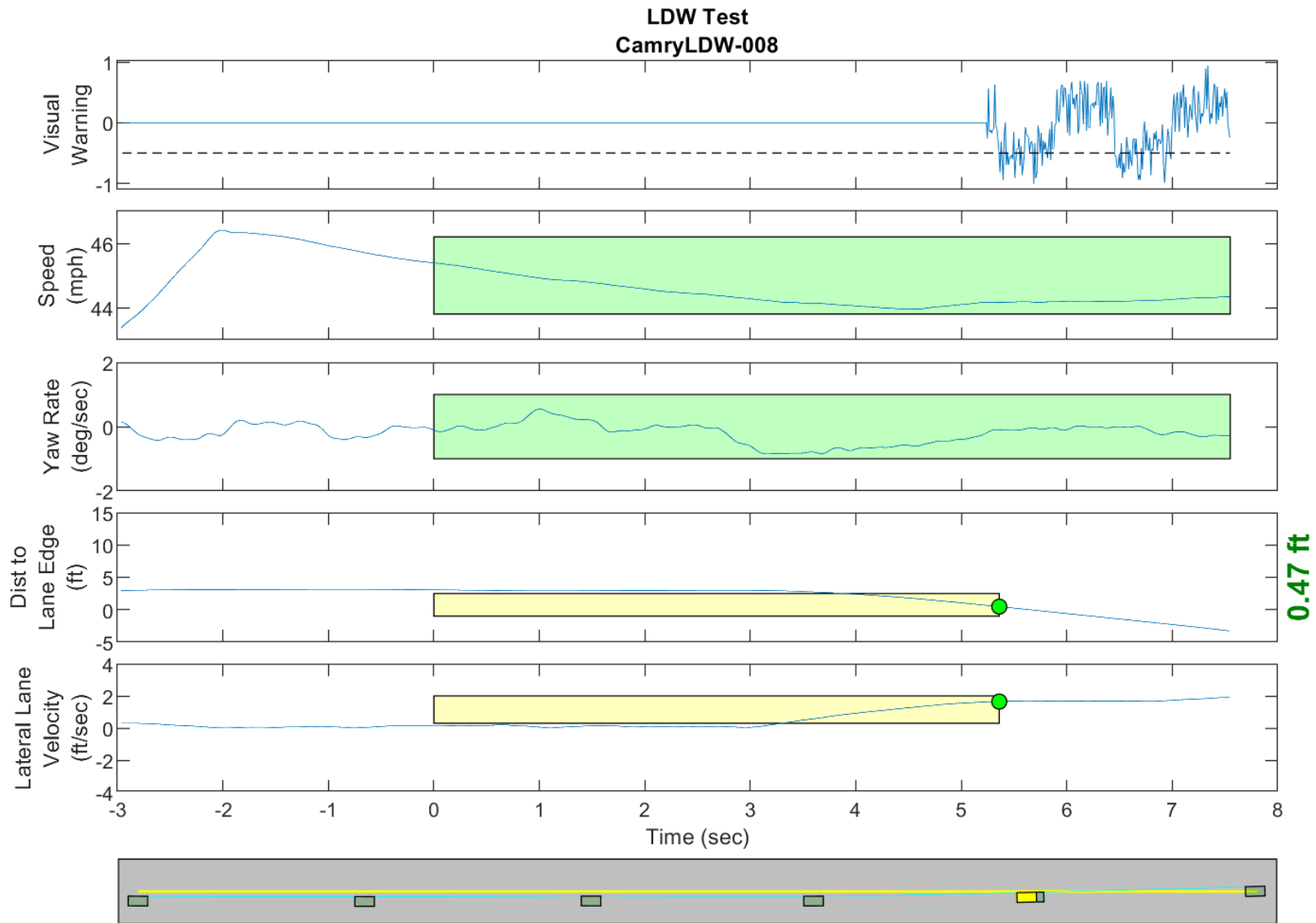

GPS Fix Type: RTK Fixed

Figure D19. Time History for Run 08, Dashed Line, Left Departure, Visual Warning

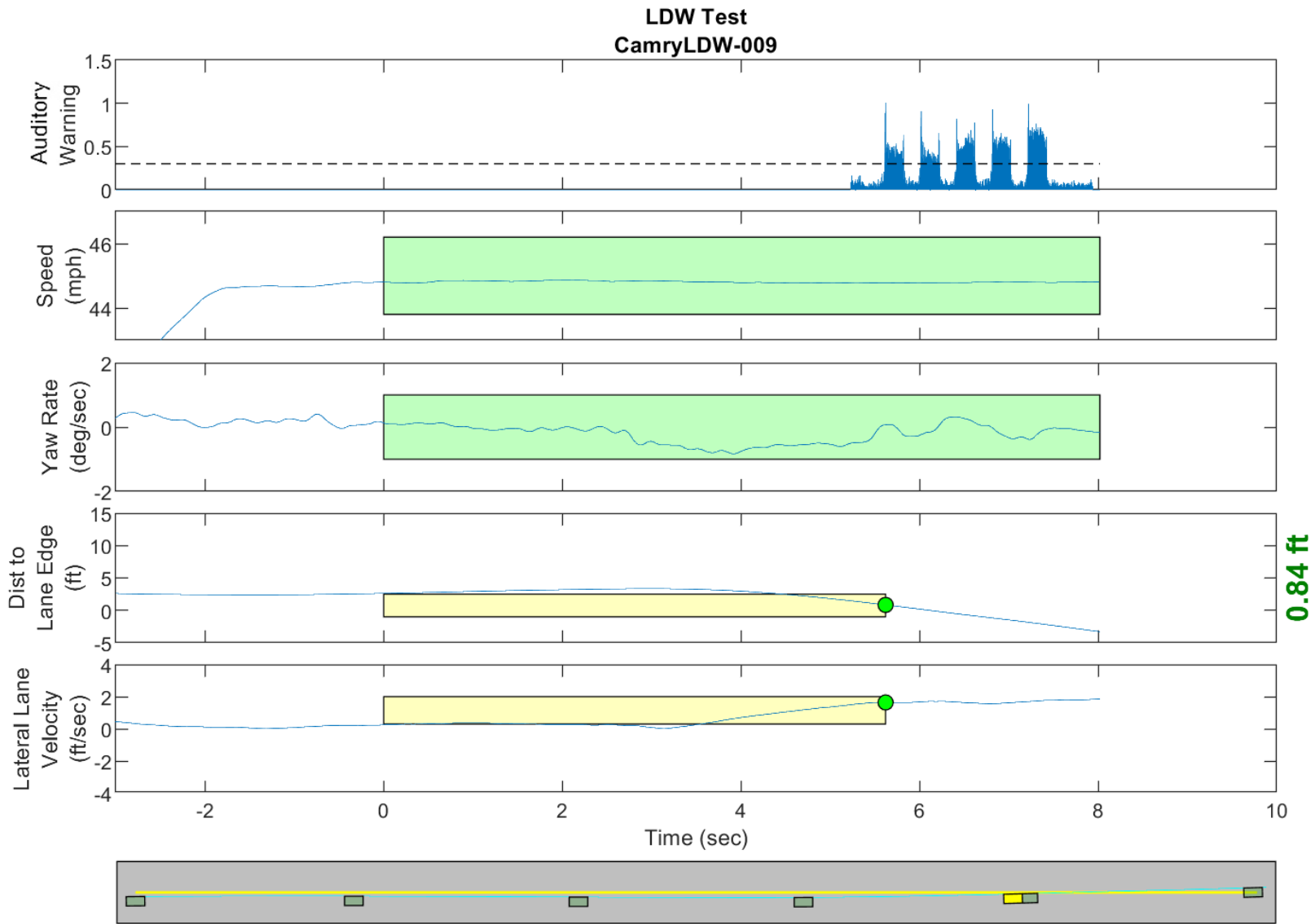

GPS Fix Type: RTK Fixed

Figure D20. Time History for Run 09, Dashed Line, Left Departure, Auditory Warning

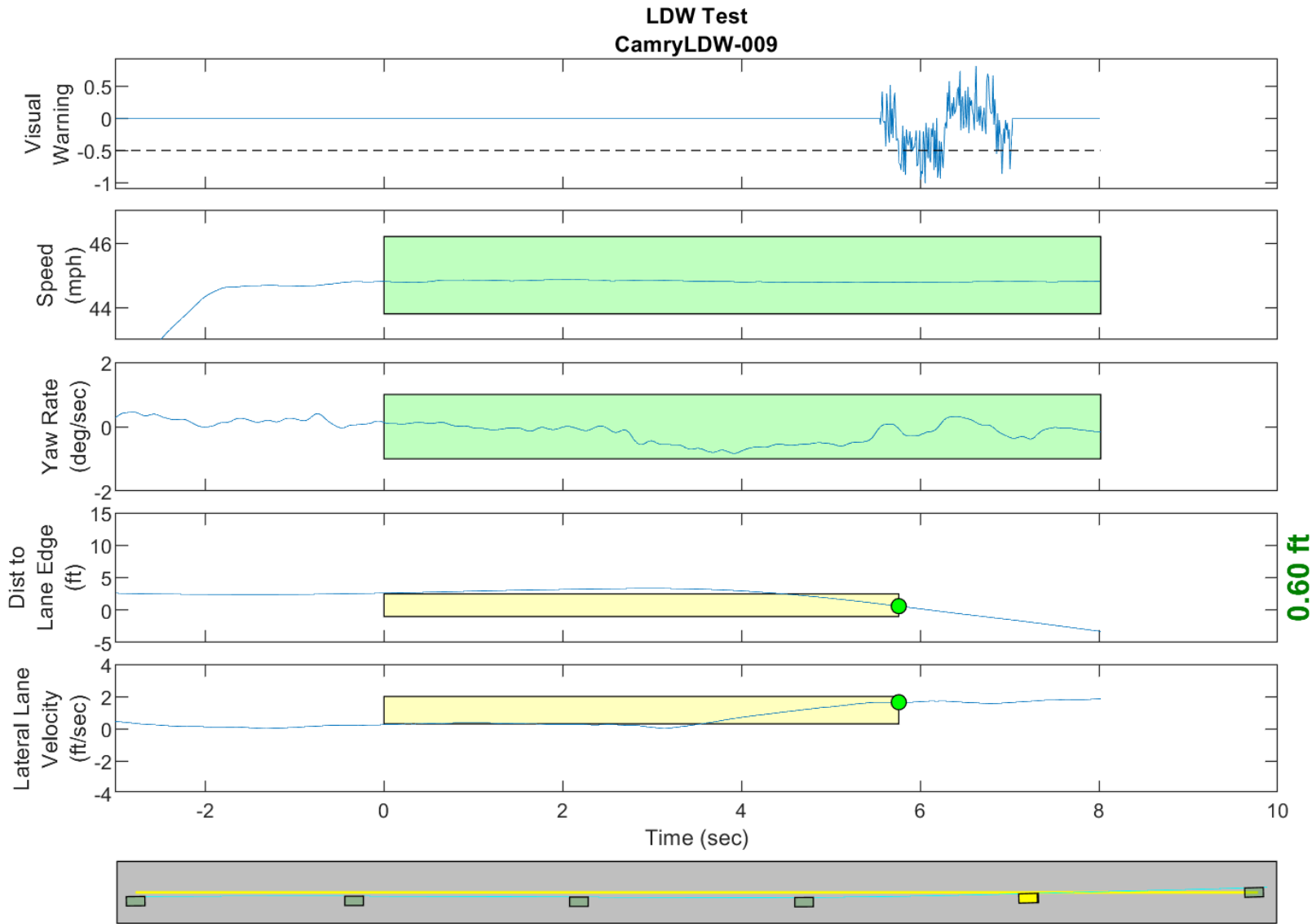

GPS Fix Type: RTK Fixed

Figure D21. Time History for Run 09, Dashed Line, Left Departure, Visual Warning

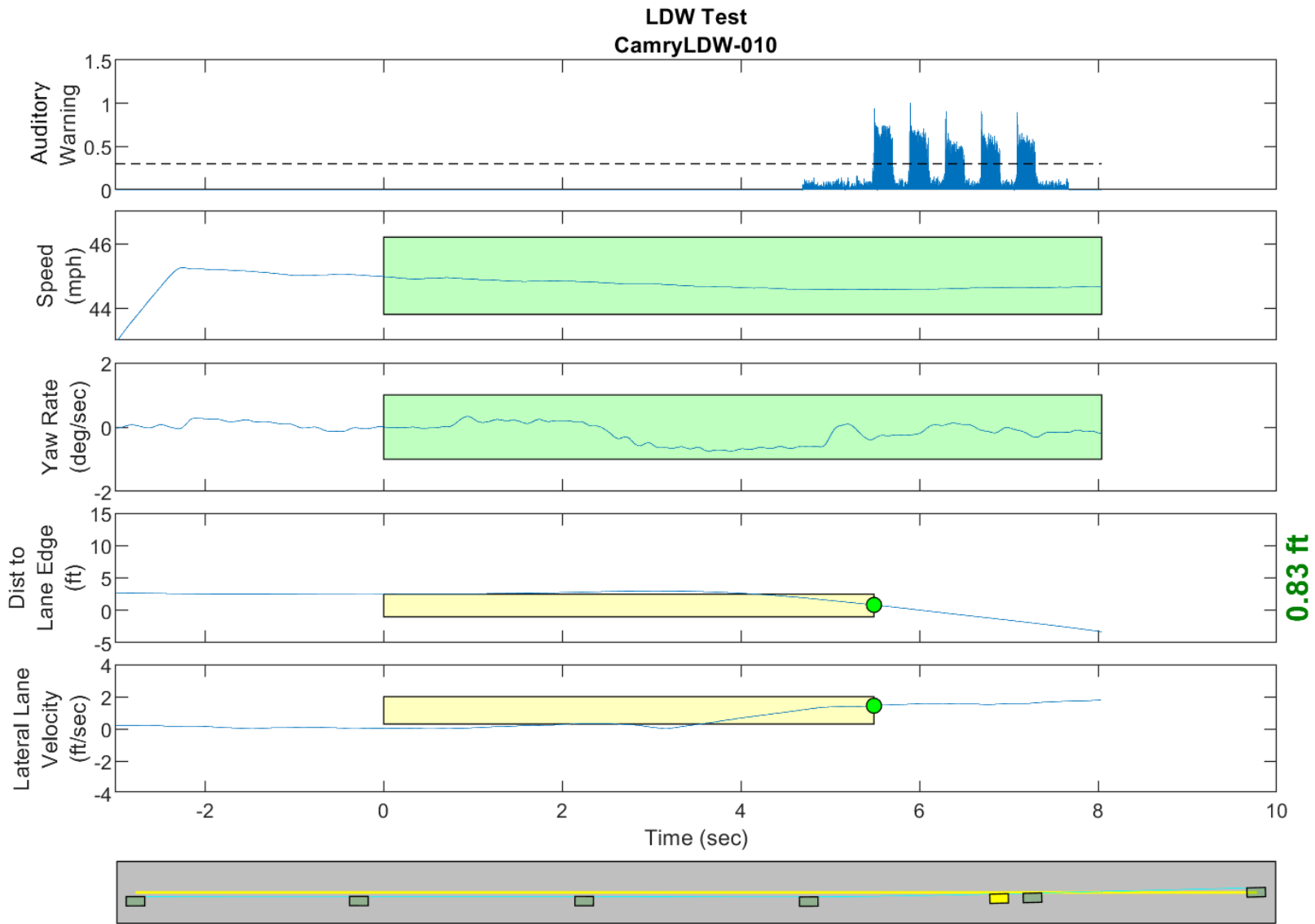

GPS Fix Type: RTK Fixed

Figure D22. Time History for Run 10, Dashed Line, Left Departure, Auditory Warning

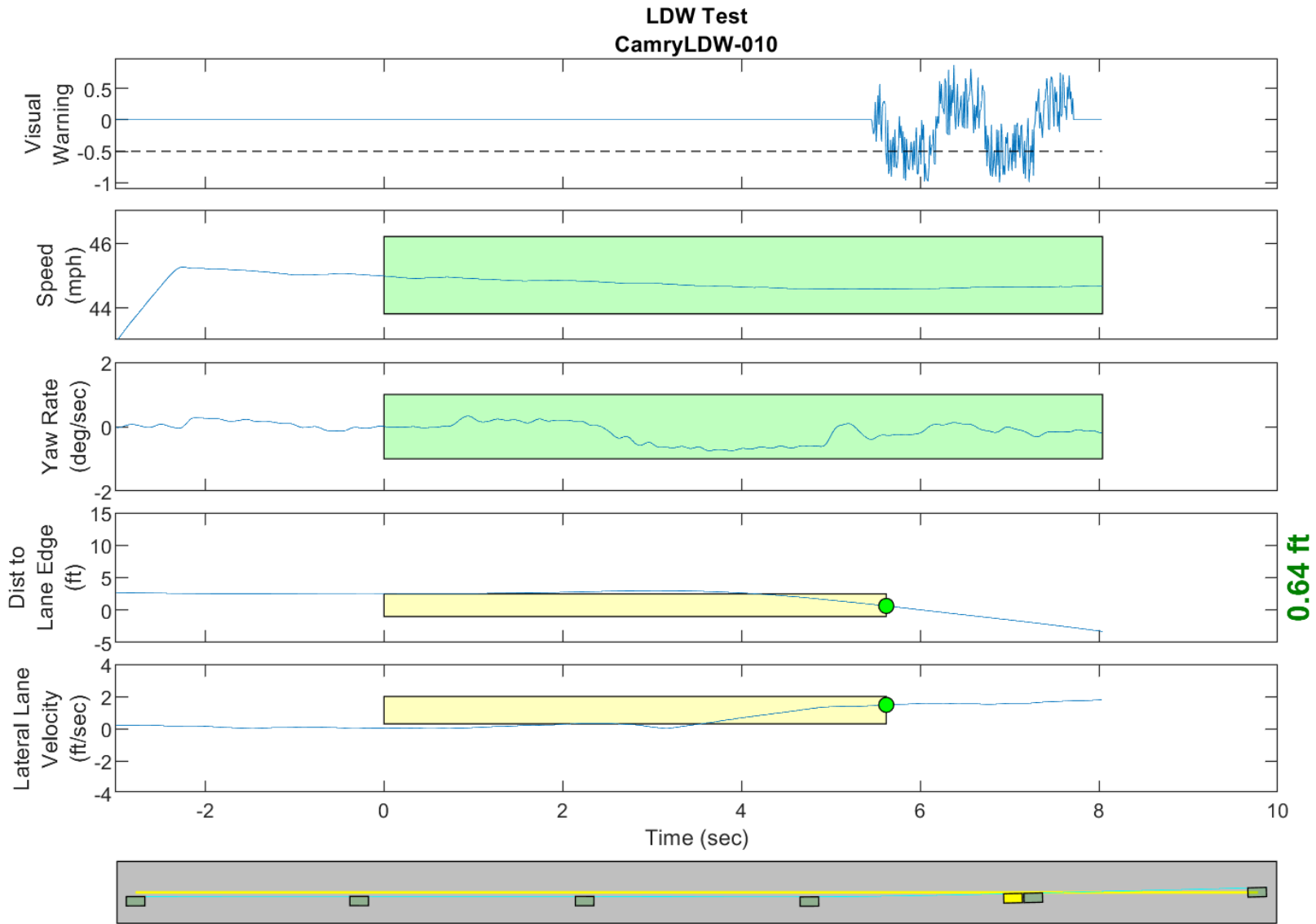

GPS Fix Type: RTK Fixed

Figure D23. Time History for Run 10, Dashed Line, Left Departure, Visual Warning

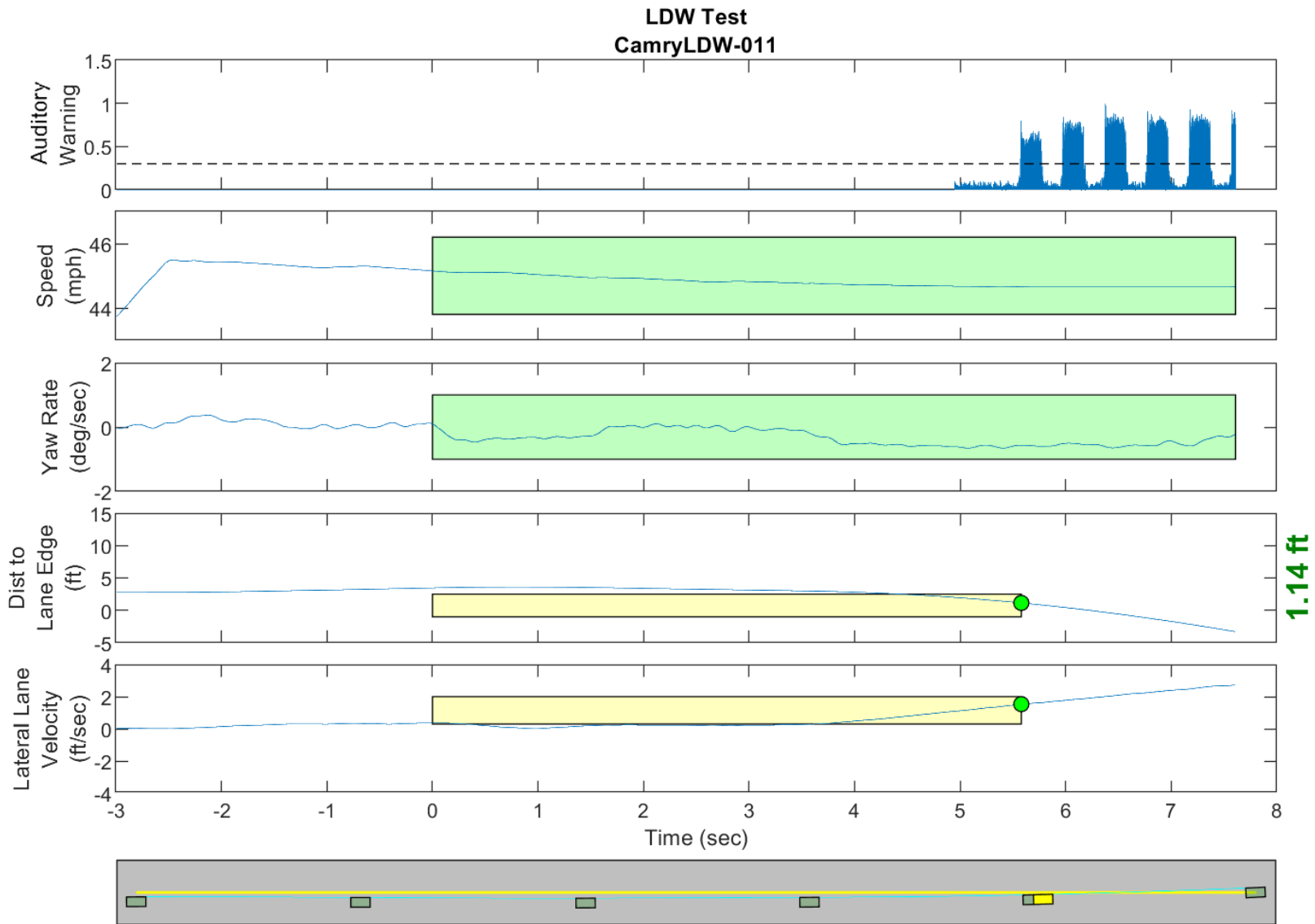

GPS Fix Type: RTK Fixed

Figure D24. Time History for Run 11, Dashed Line, Left Departure, Auditory Warning

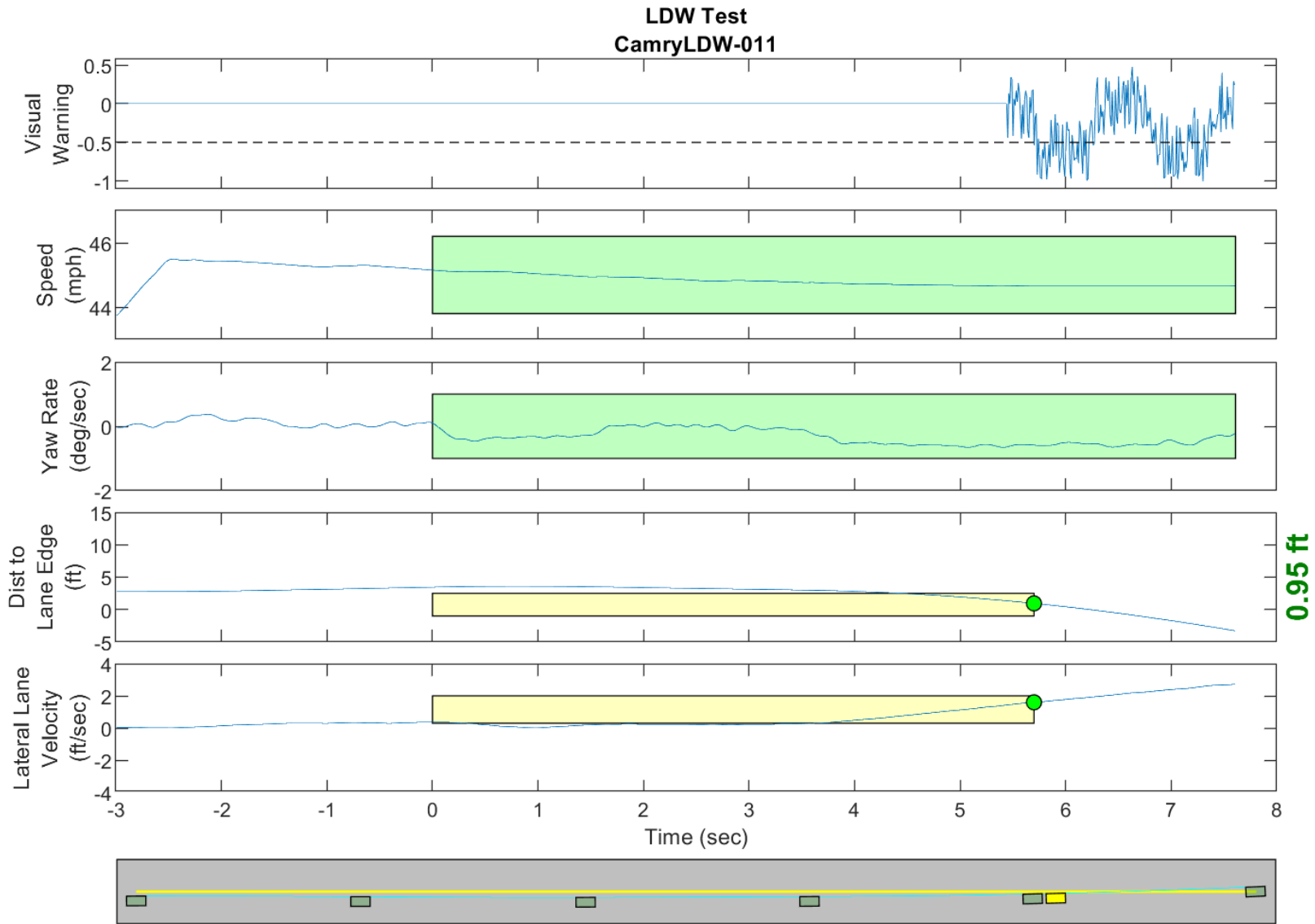

GPS Fix Type: RTK Fixed

Figure D25. Time History for Run 11, Dashed Line, Left Departure, Visual Warning

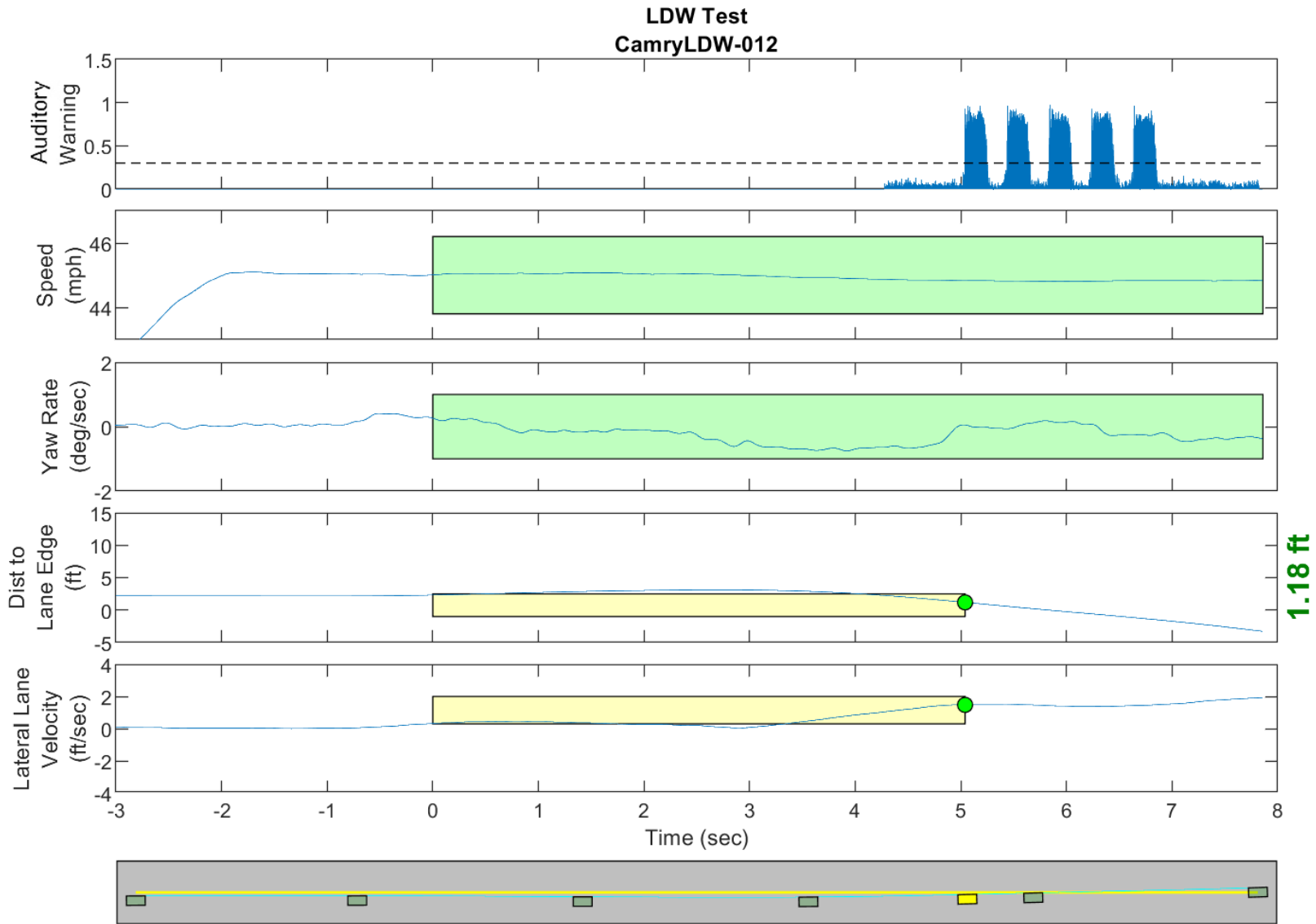

GPS Fix Type: RTK Fixed

Figure D26. Time History for Run 12, Dashed Line, Left Departure, Auditory Warning

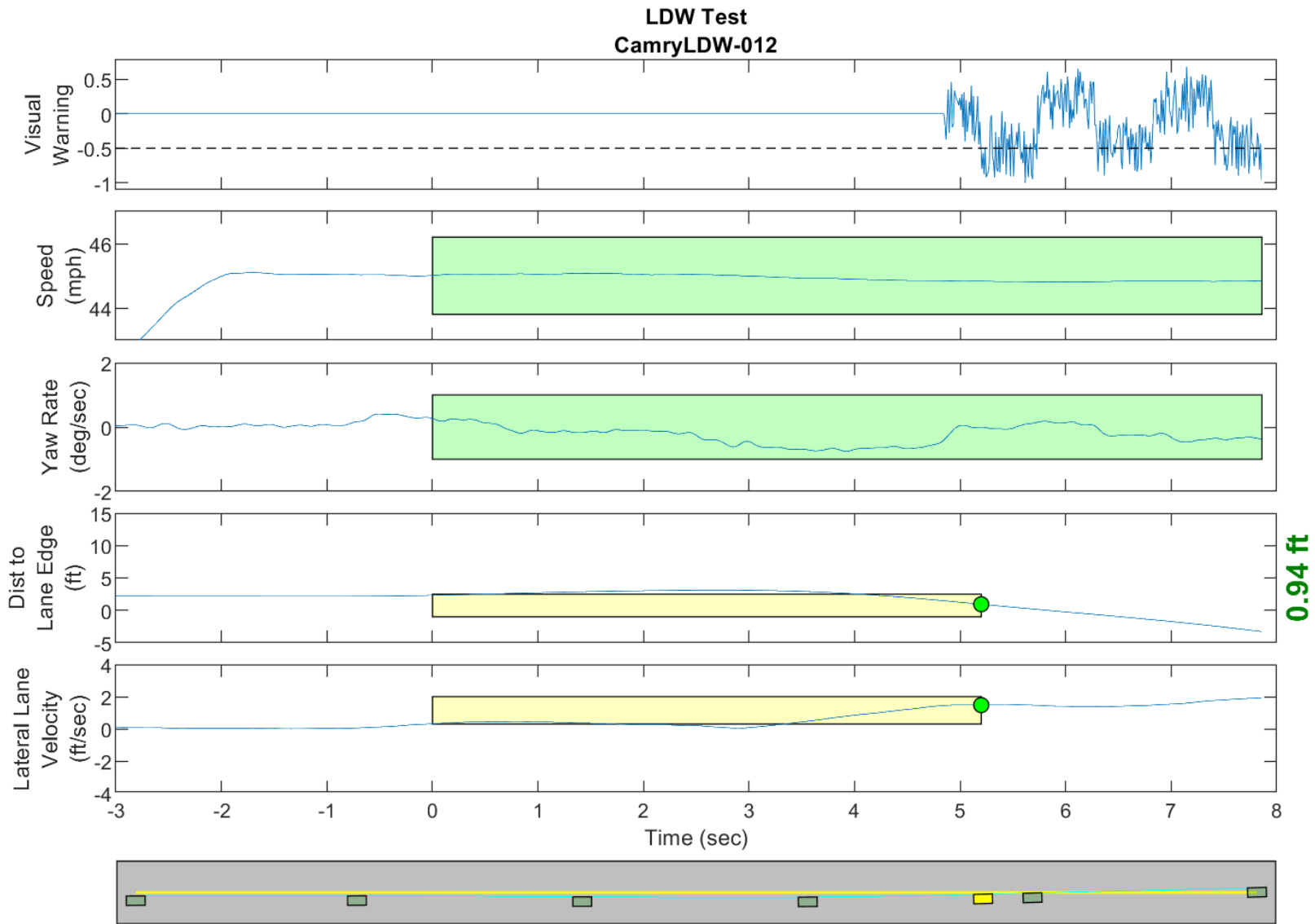

GPS Fix Type: RTK Fixed

Figure D27. Time History for Run 12, Dashed Line, Left Departure, Visual Warning

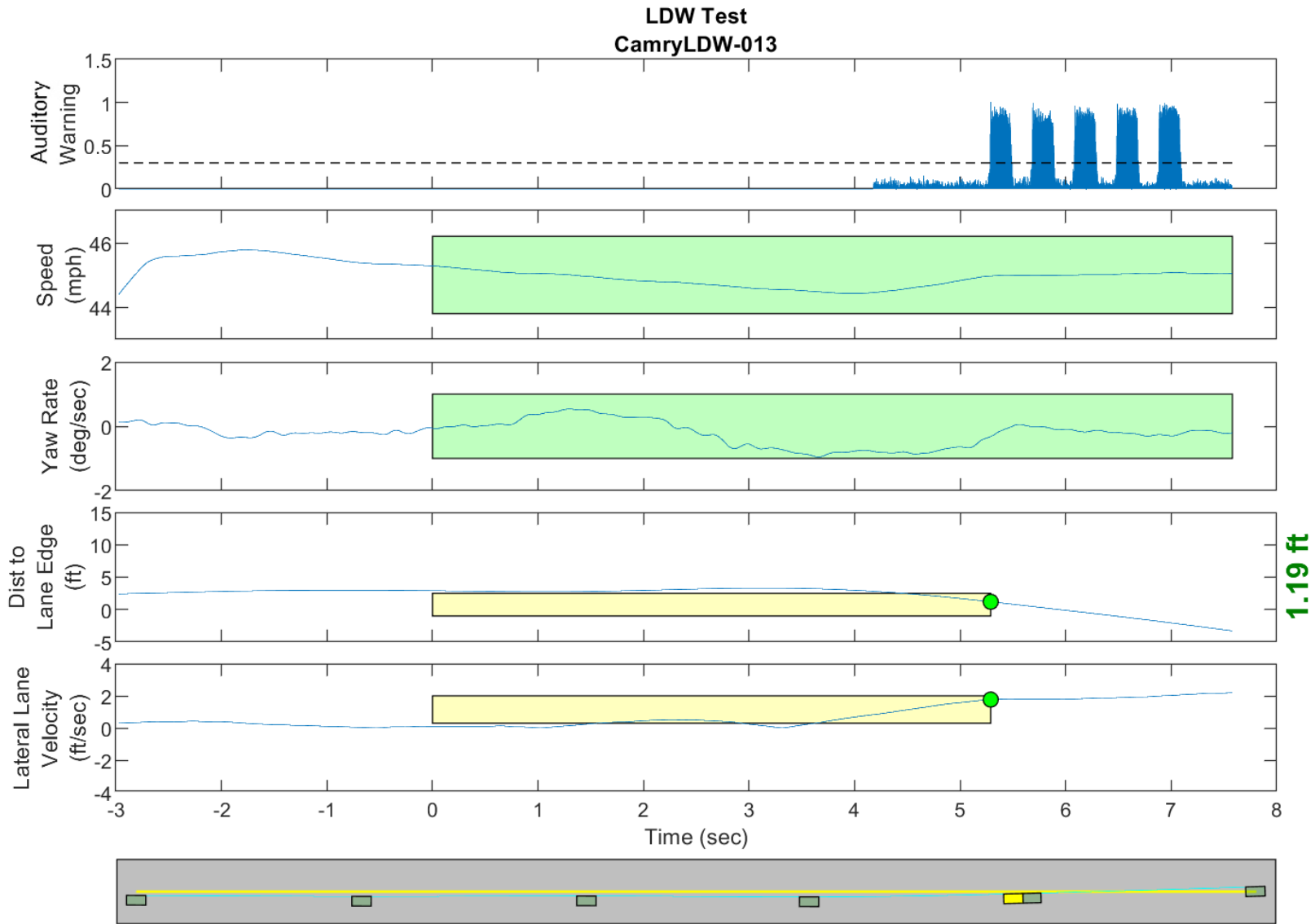

GPS Fix Type: RTK Fixed

Figure D28. Time History for Run 13, Dashed Line, Left Departure, Auditory Warning

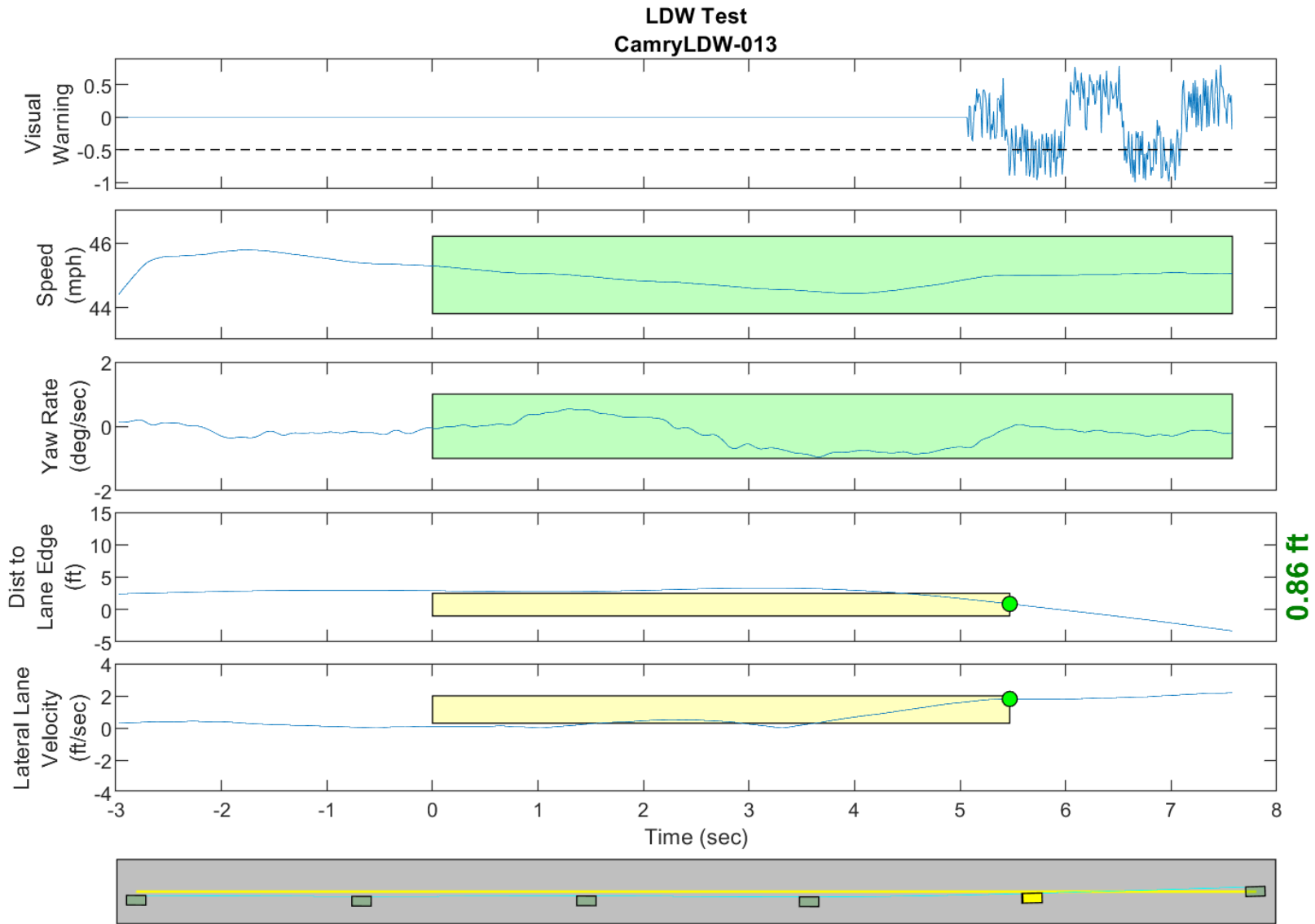

GPS Fix Type: RTK Fixed

Figure D29. Time History for Run 13, Dashed Line, Left Departure, Visual Warning

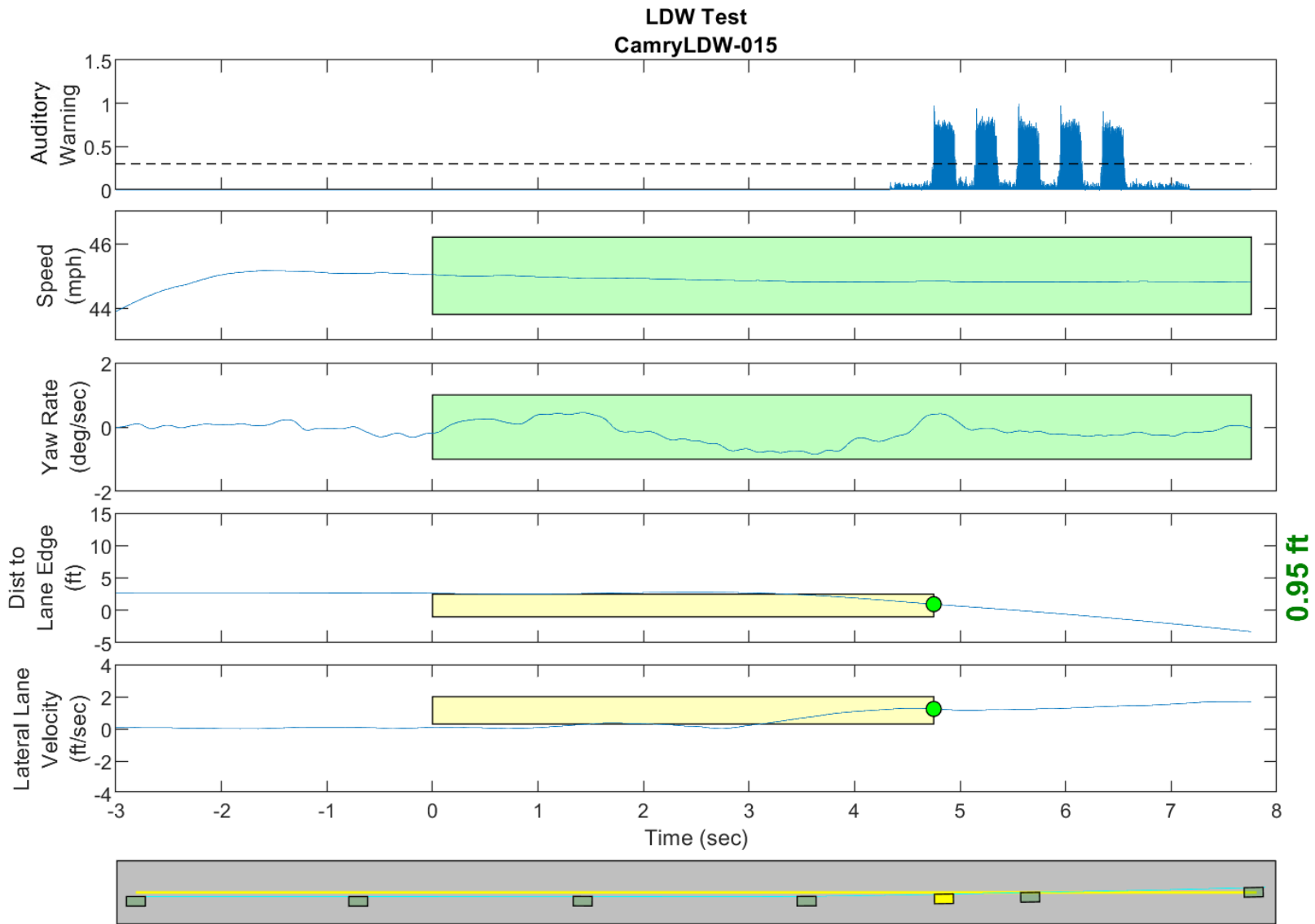

GPS Fix Type: RTK Fixed

Figure D30. Time History for Run 15, Dashed Line, Left Departure, Auditory Warning

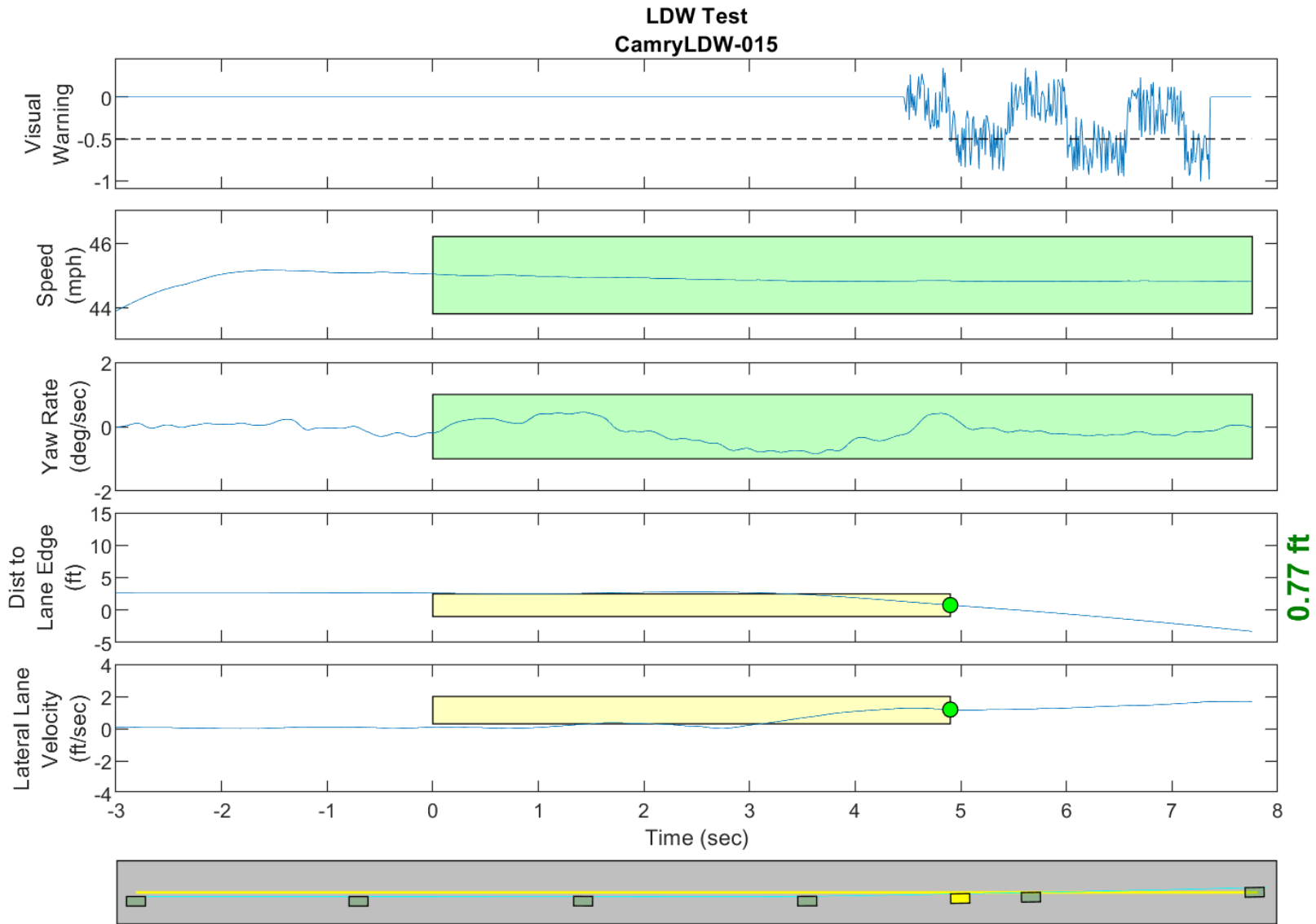

GPS Fix Type: RTK Fixed

Figure D31. Time History for Run 15, Dashed Line, Left Departure, Visual Warning

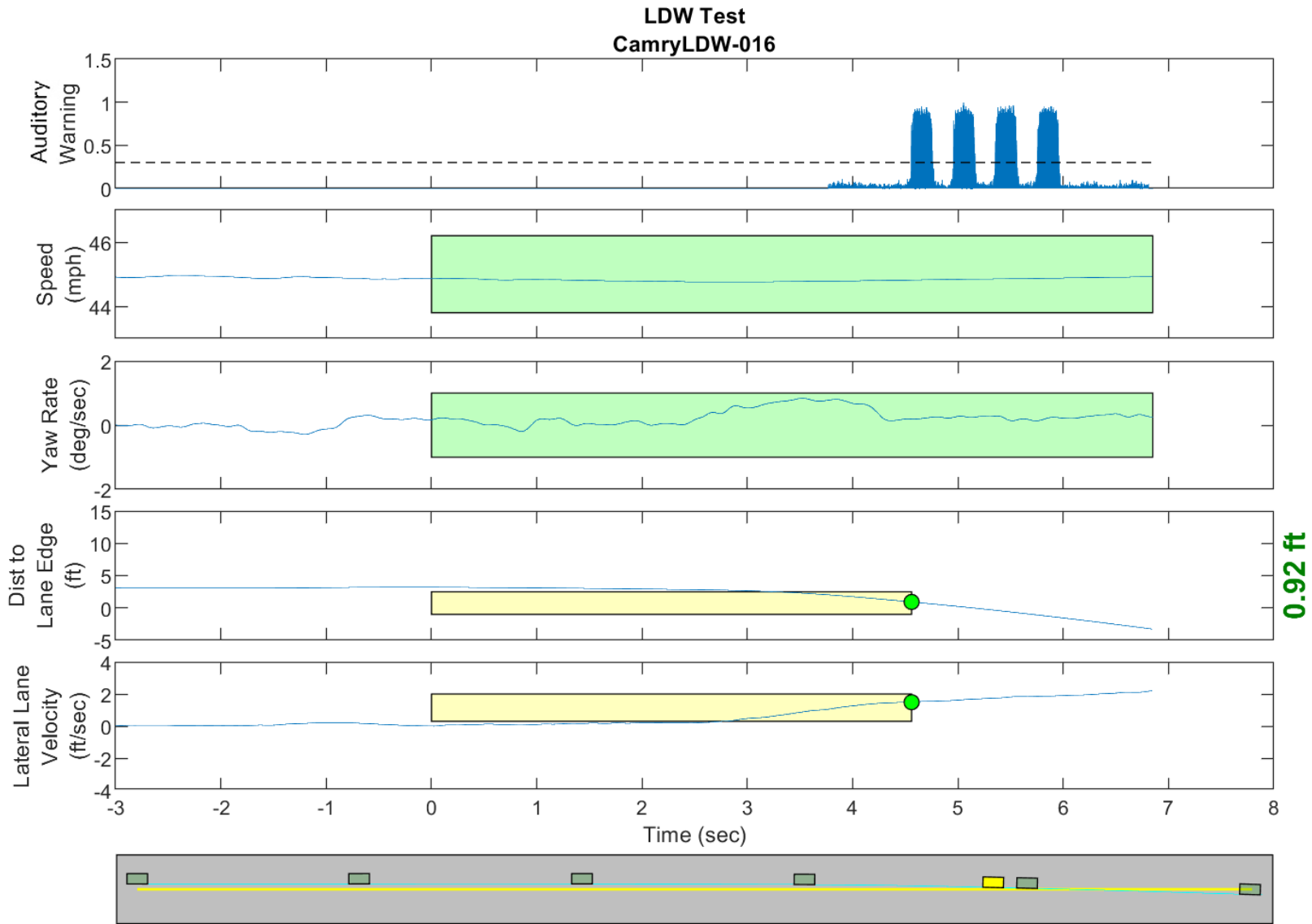

GPS Fix Type: RTK Fixed

Figure D32. Time History for Run 16, Solid Line, Right Departure, Auditory Warning

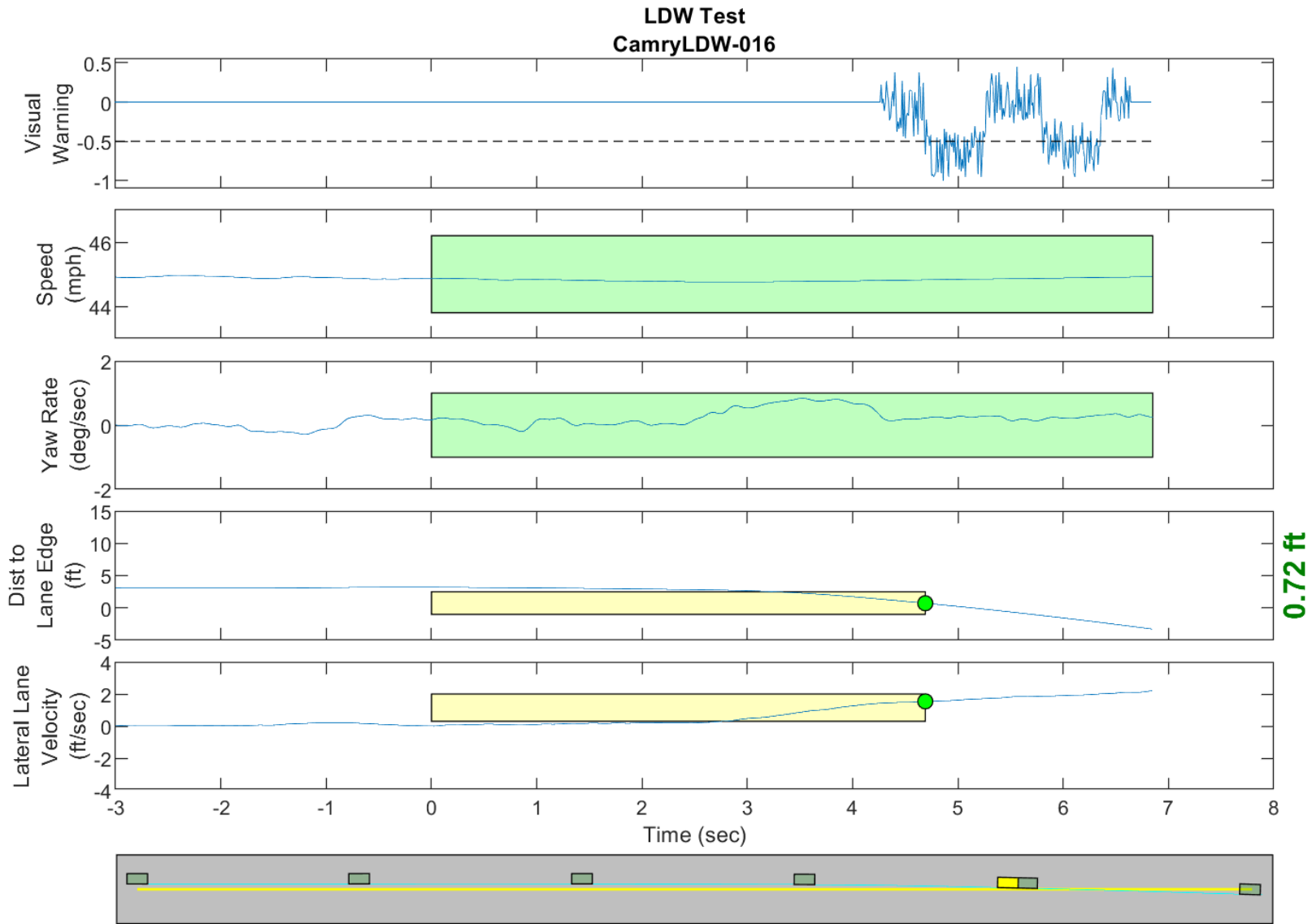

GPS Fix Type: RTK Fixed

Figure D33. Time History for Run 16, Solid Line, Right Departure, Visual Warning

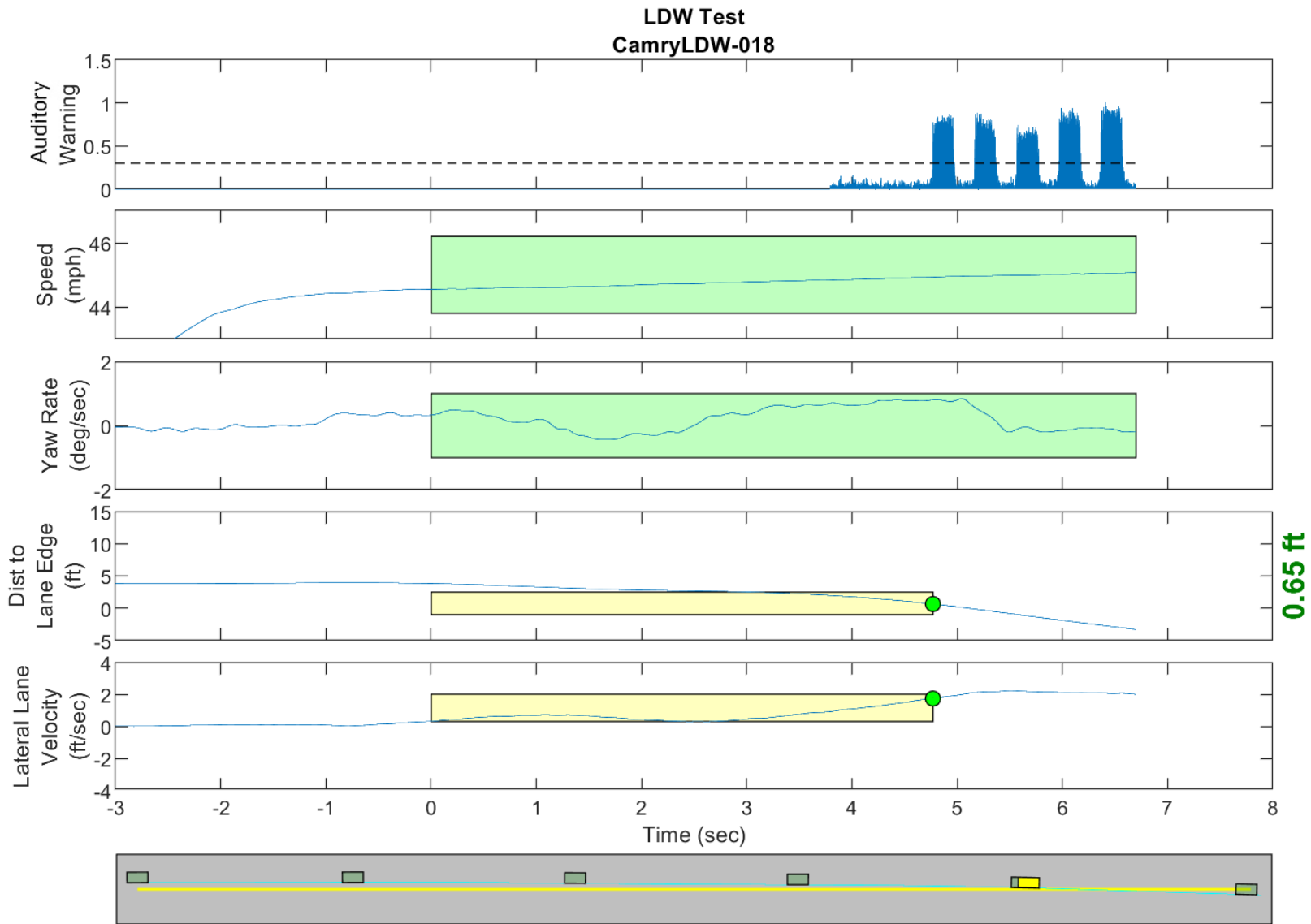

GPS Fix Type: RTK Fixed

Figure D34. Time History for Run 18, Solid Line, Right Departure, Auditory Warning

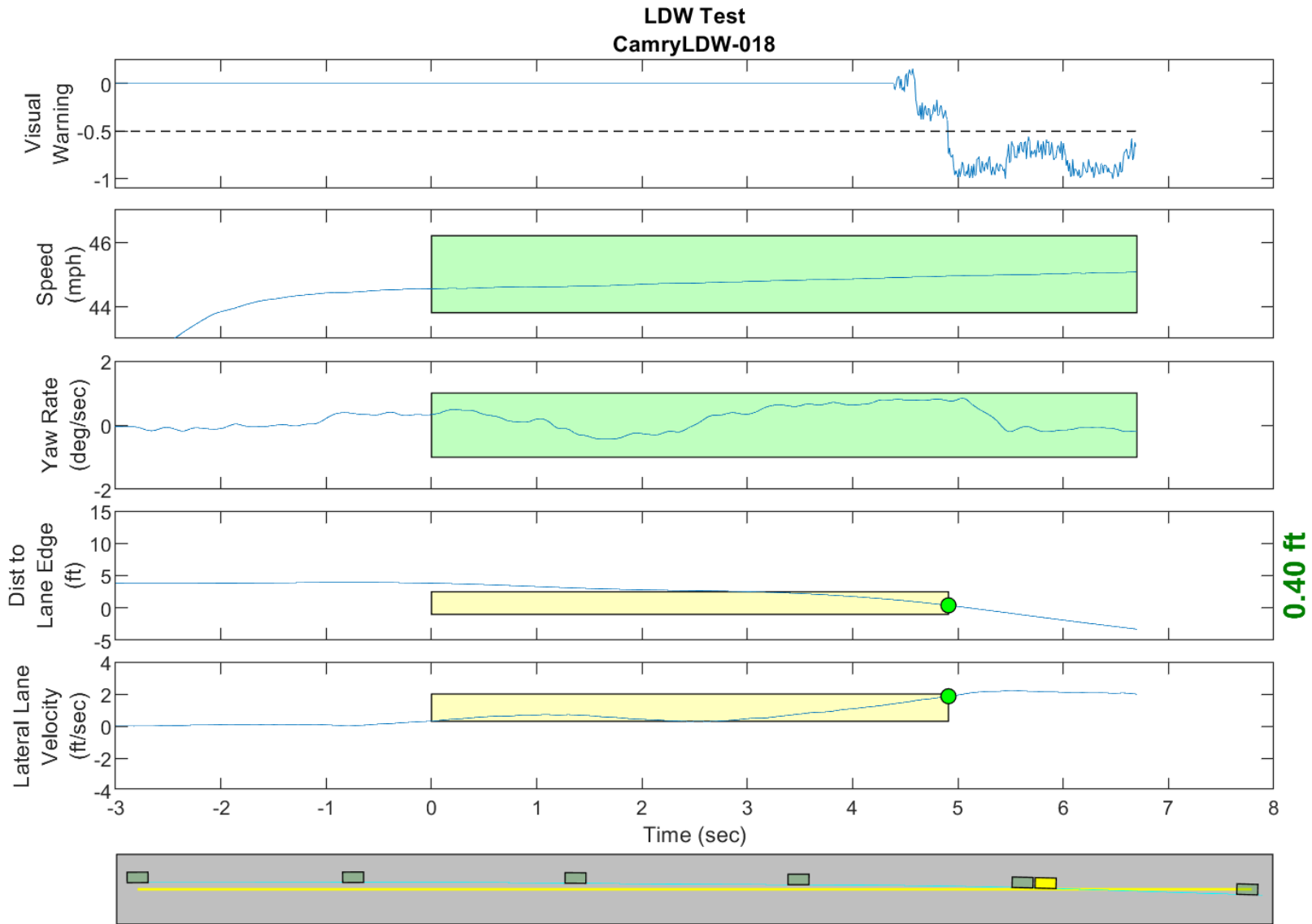

GPS Fix Type: RTK Fixed

Figure D35. Time History for Run 18, Solid Line, Right Departure, Visual Warning

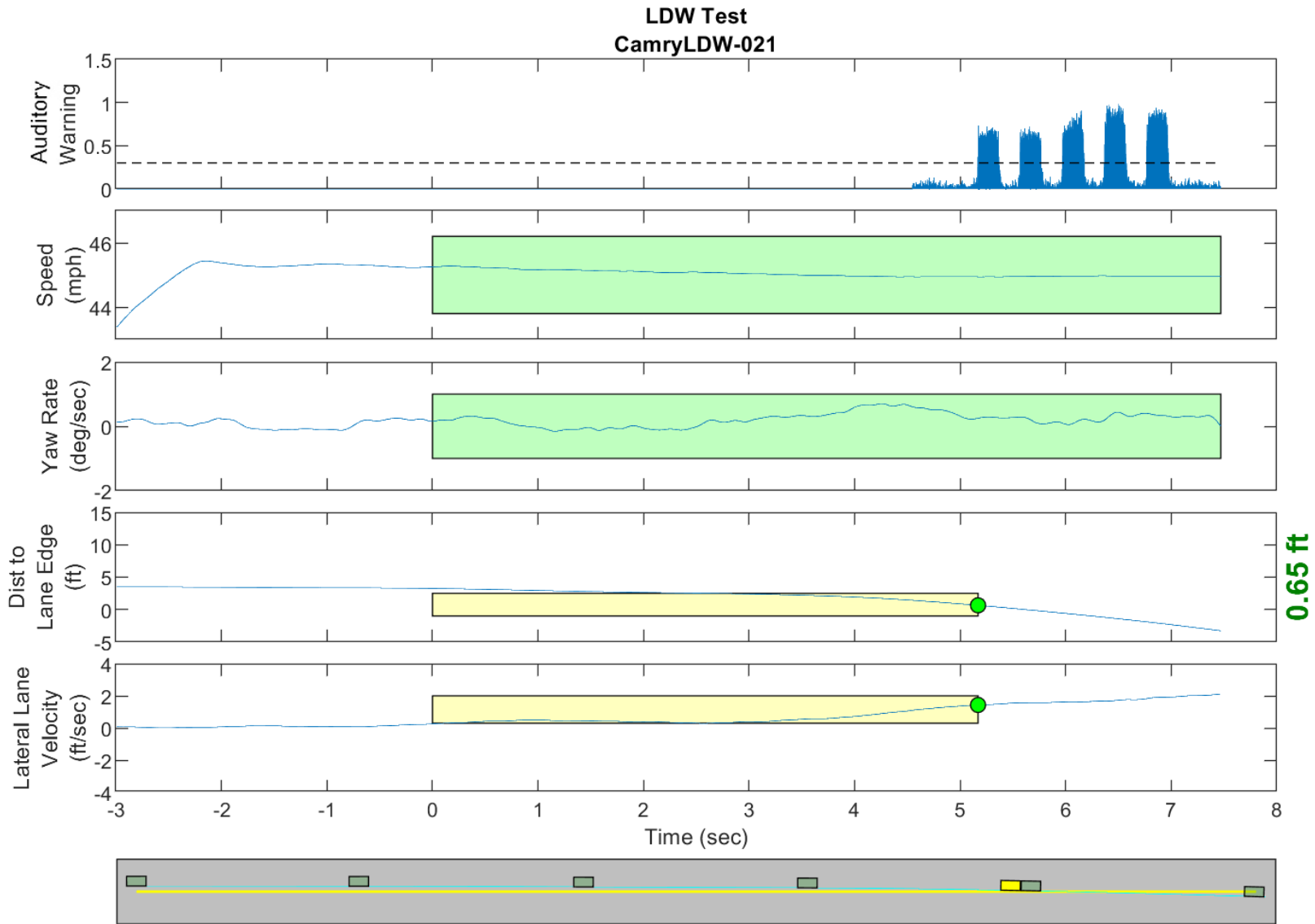

GPS Fix Type: RTK Fixed

Figure D36. Time History for Run 21, Solid Line, Right Departure, Auditory Warning

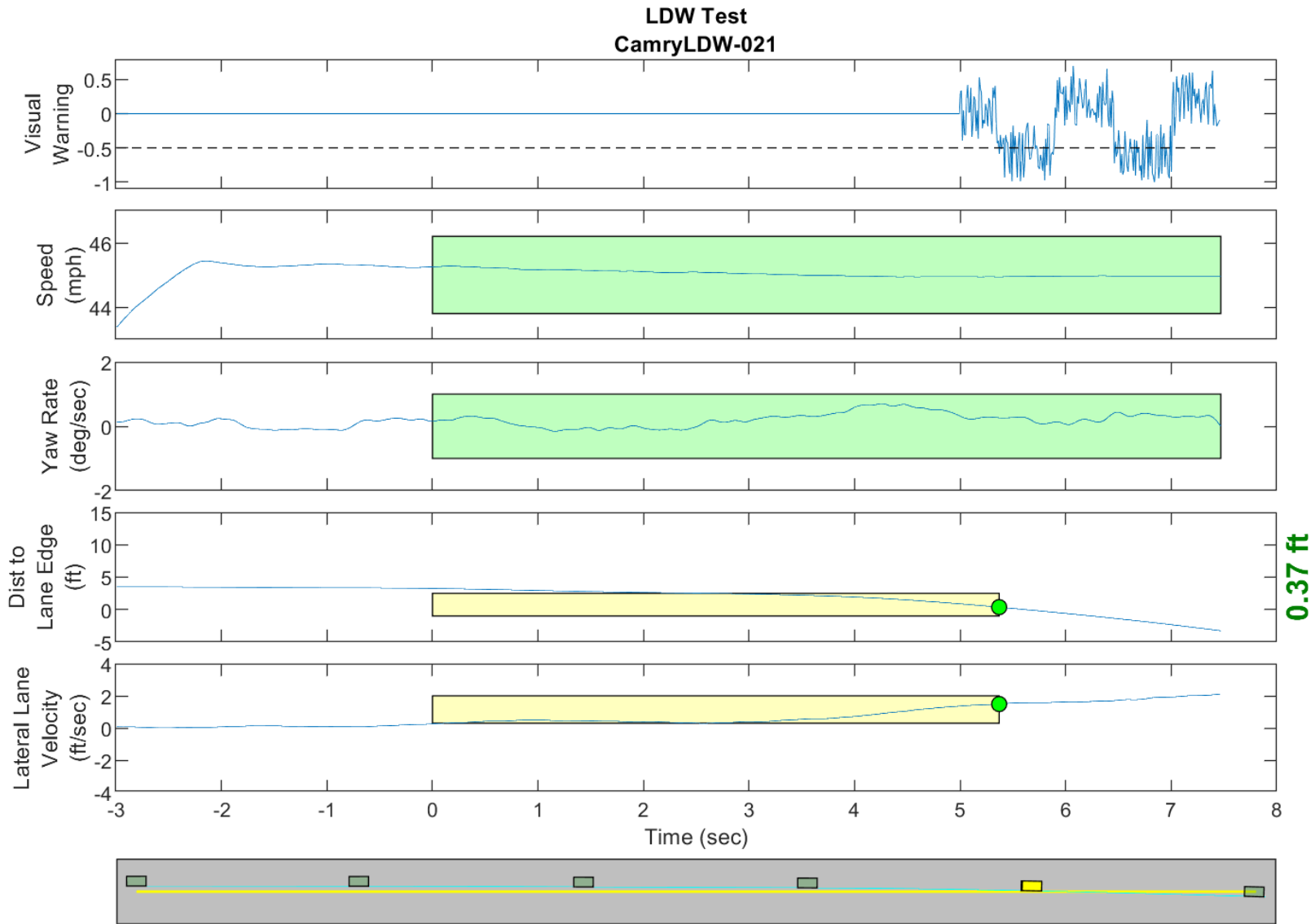

GPS Fix Type: RTK Fixed

Figure D37. Time History for Run 21, Solid Line, Right Departure, Visual Warning

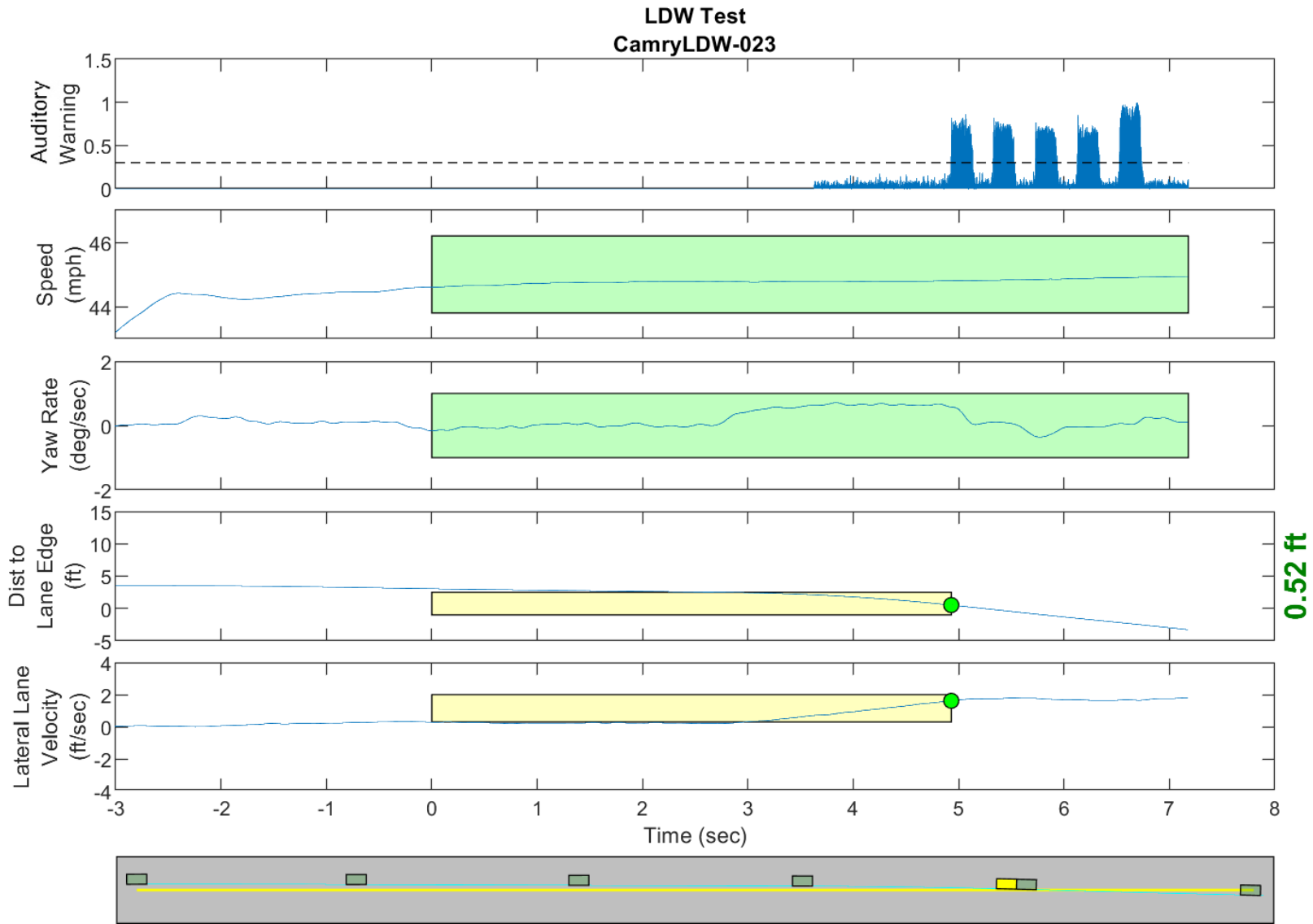

GPS Fix Type: RTK Fixed

Figure D38. Time History for Run 23, Solid Line, Right Departure, Auditory Warning

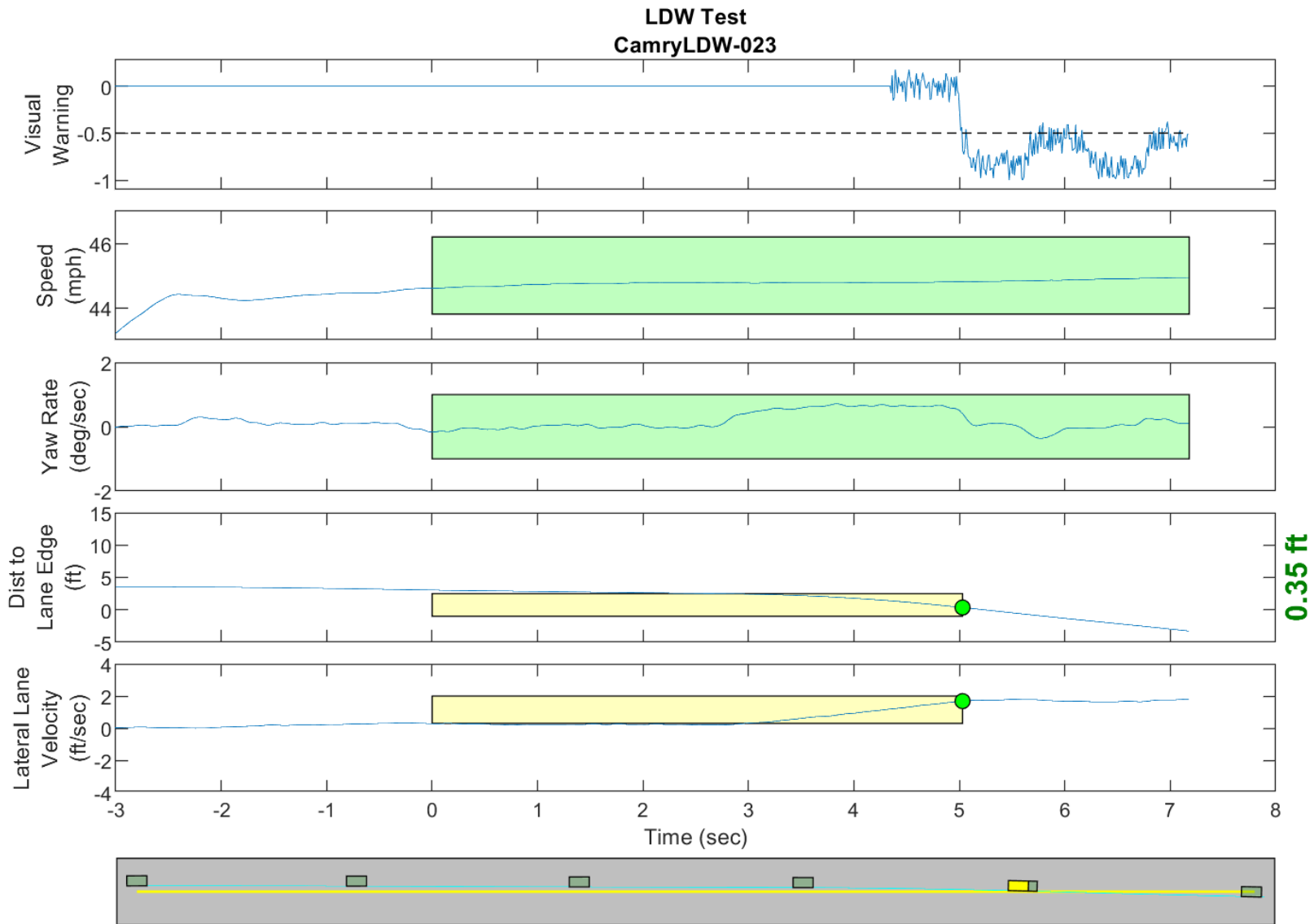

GPS Fix Type: RTK Fixed

Figure D39. Time History for Run 23, Solid Line, Right Departure, Visual Warning

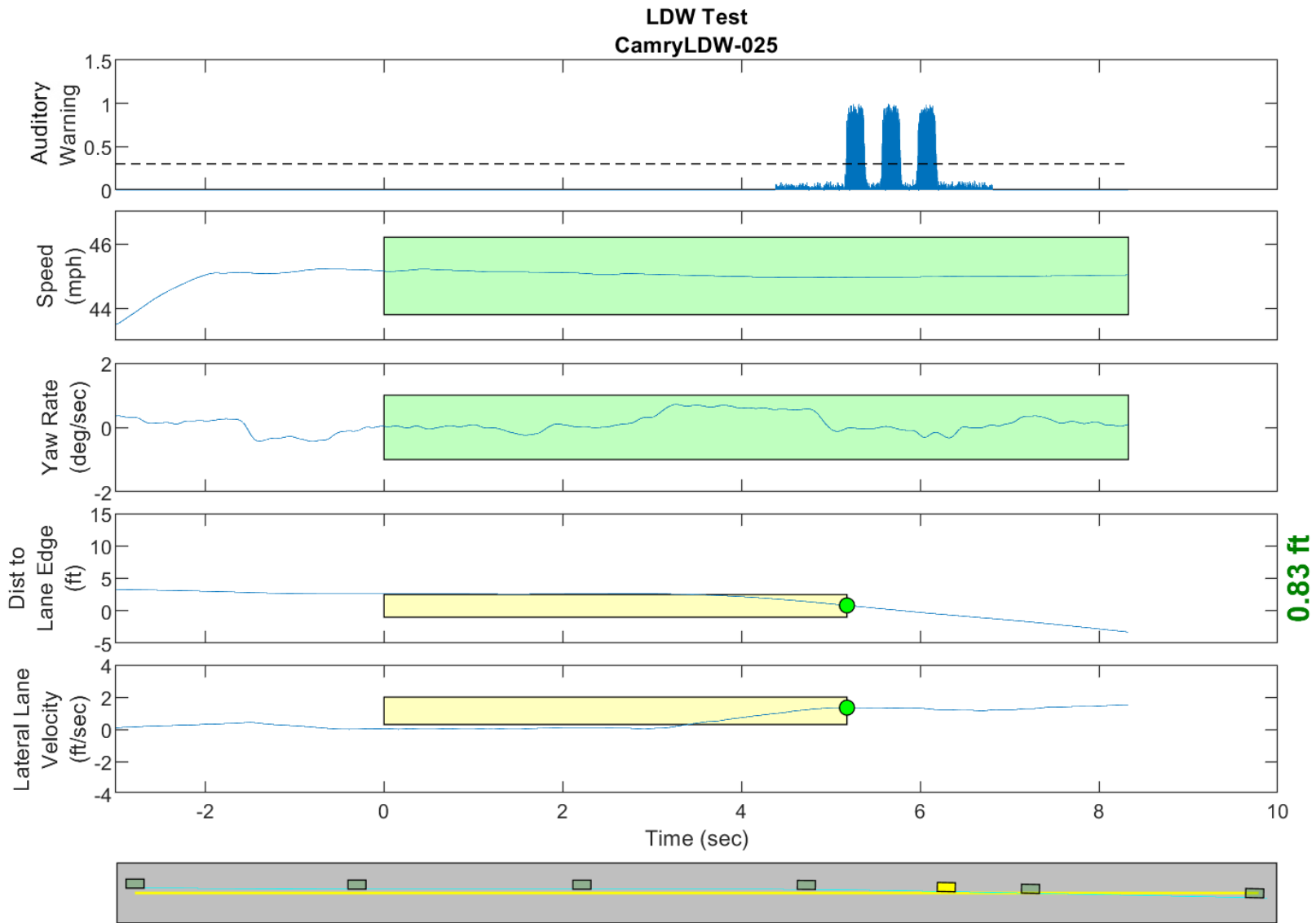

GPS Fix Type: RTK Fixed

Figure D40. Time History for Run 25, Solid Line, Right Departure, Auditory Warning

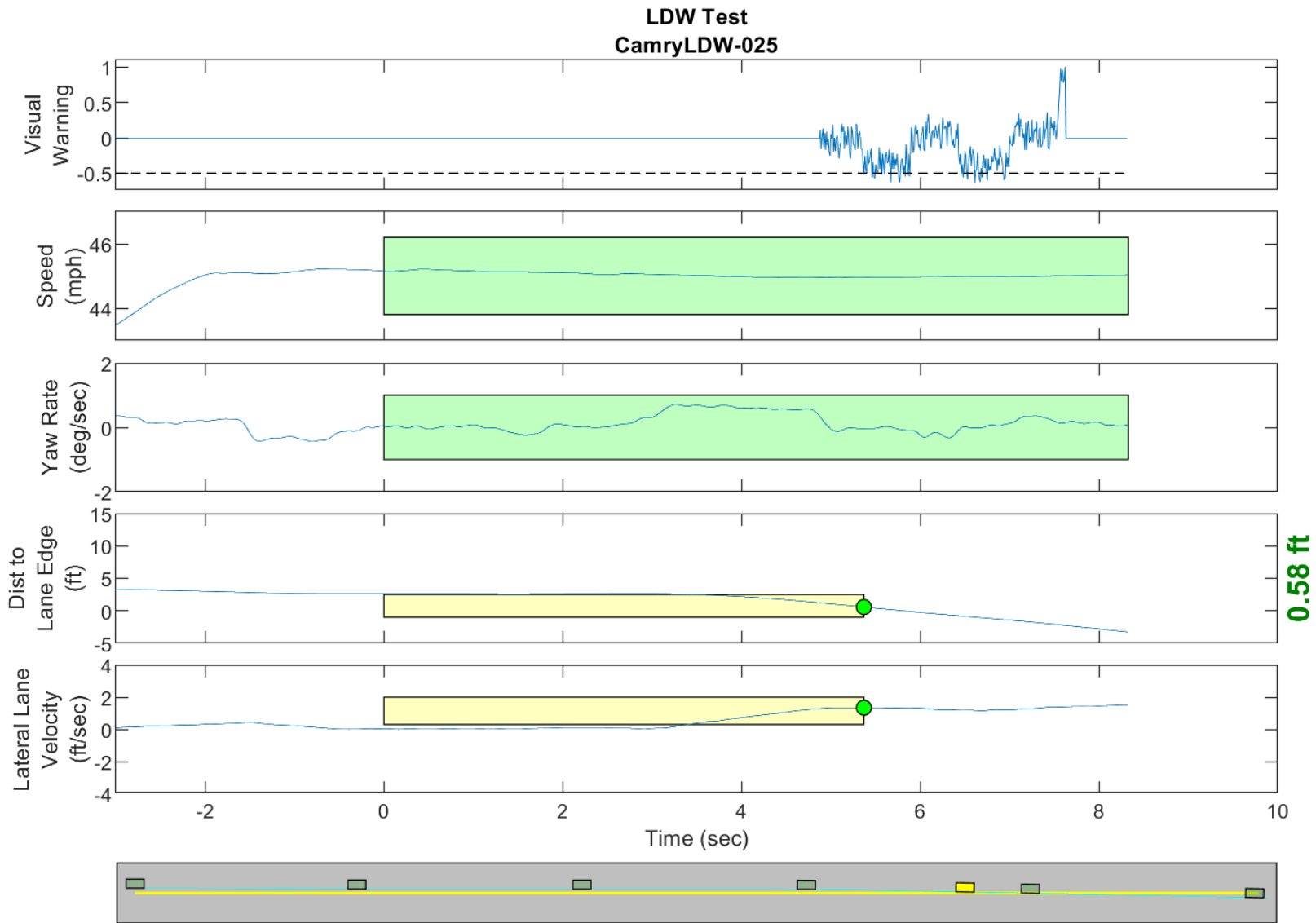

GPS Fix Type: RTK Fixed

Figure D41. Time History for Run 25, Solid Line, Right Departure, Visual Warning

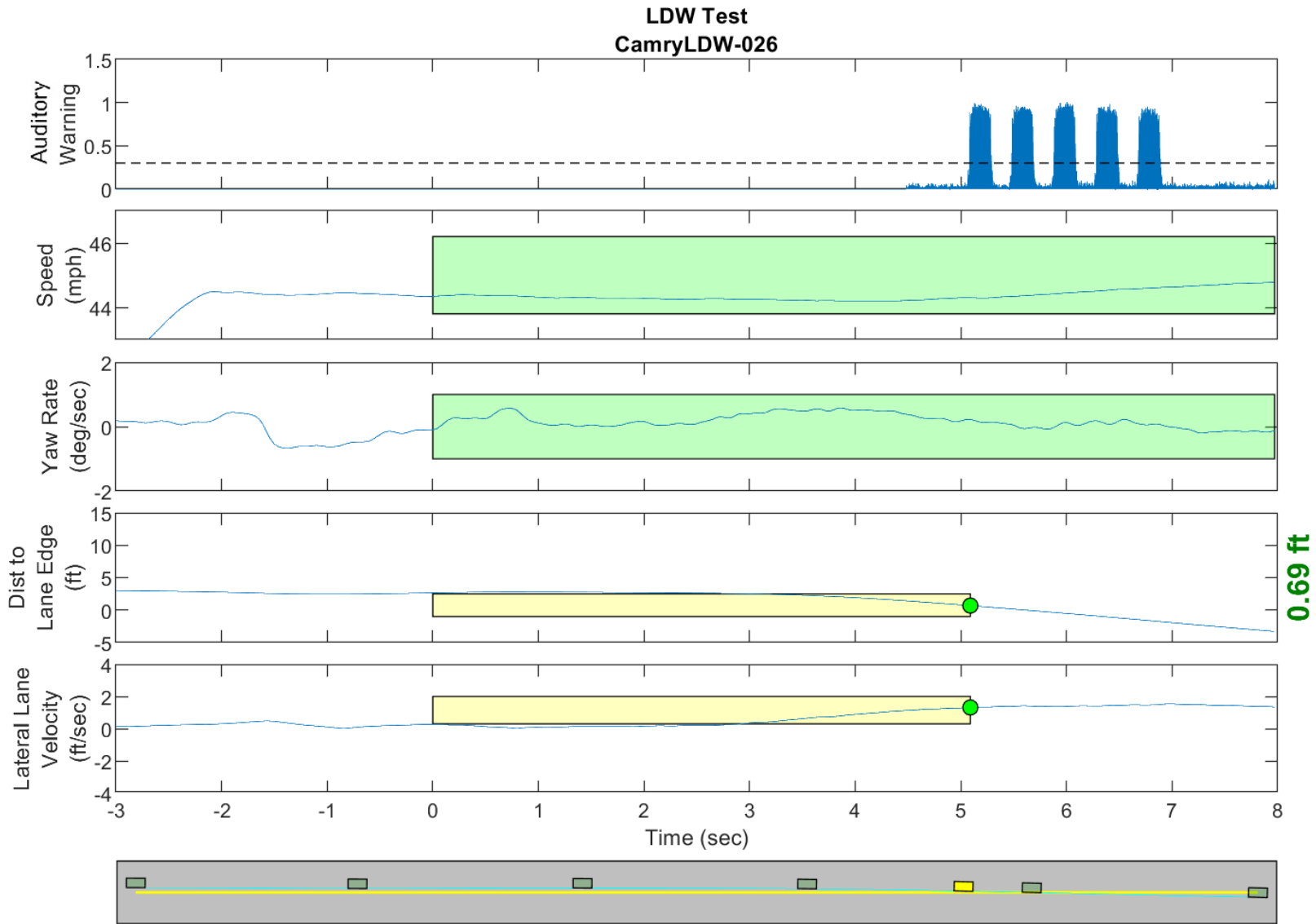

GPS Fix Type: RTK Fixed

Figure D42. Time History for Run 26, Solid Line, Right Departure, Auditory Warning

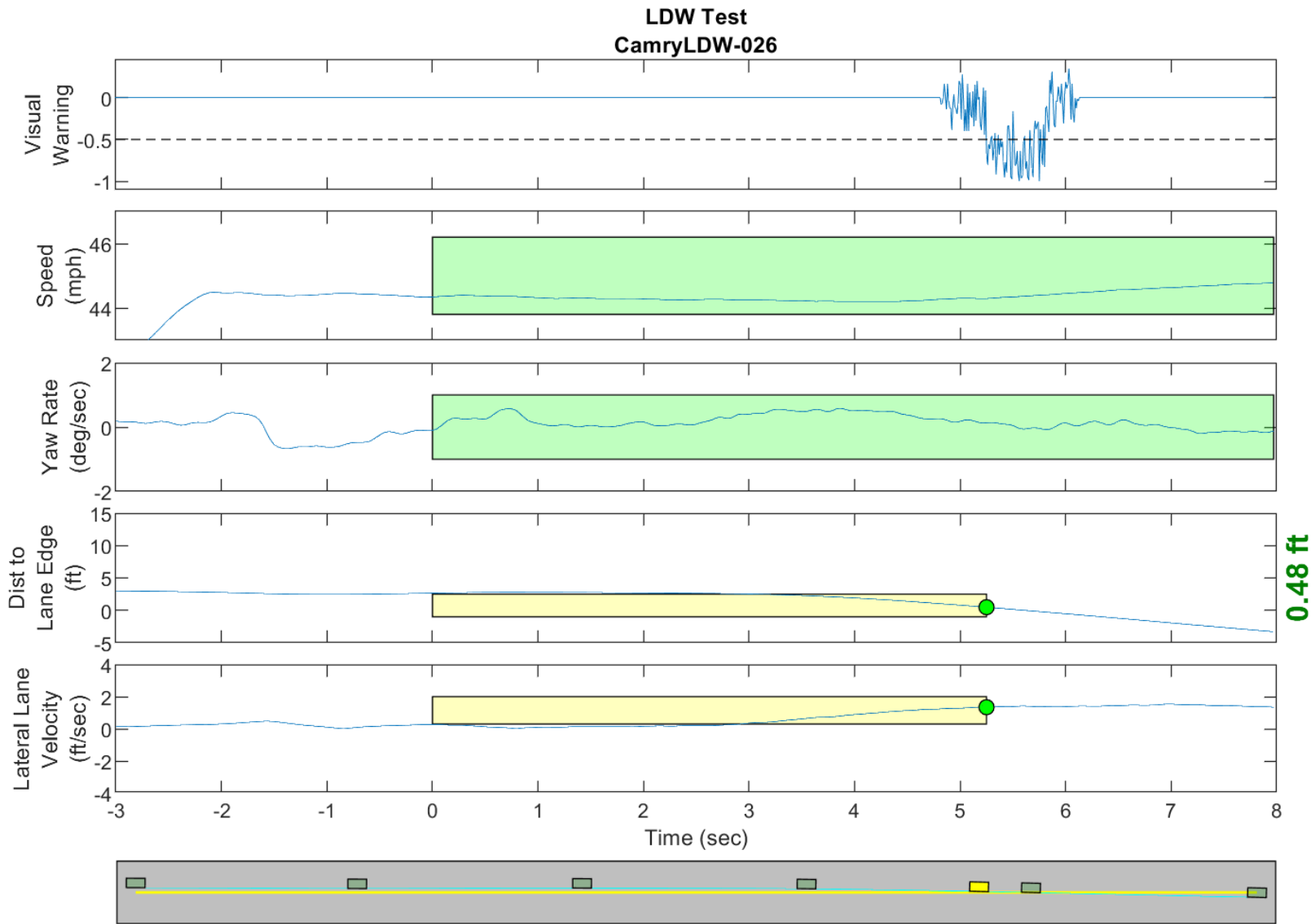

GPS Fix Type: RTK Fixed

Figure D43. Time History for Run 26, Solid Line, Right Departure, Visual Warning

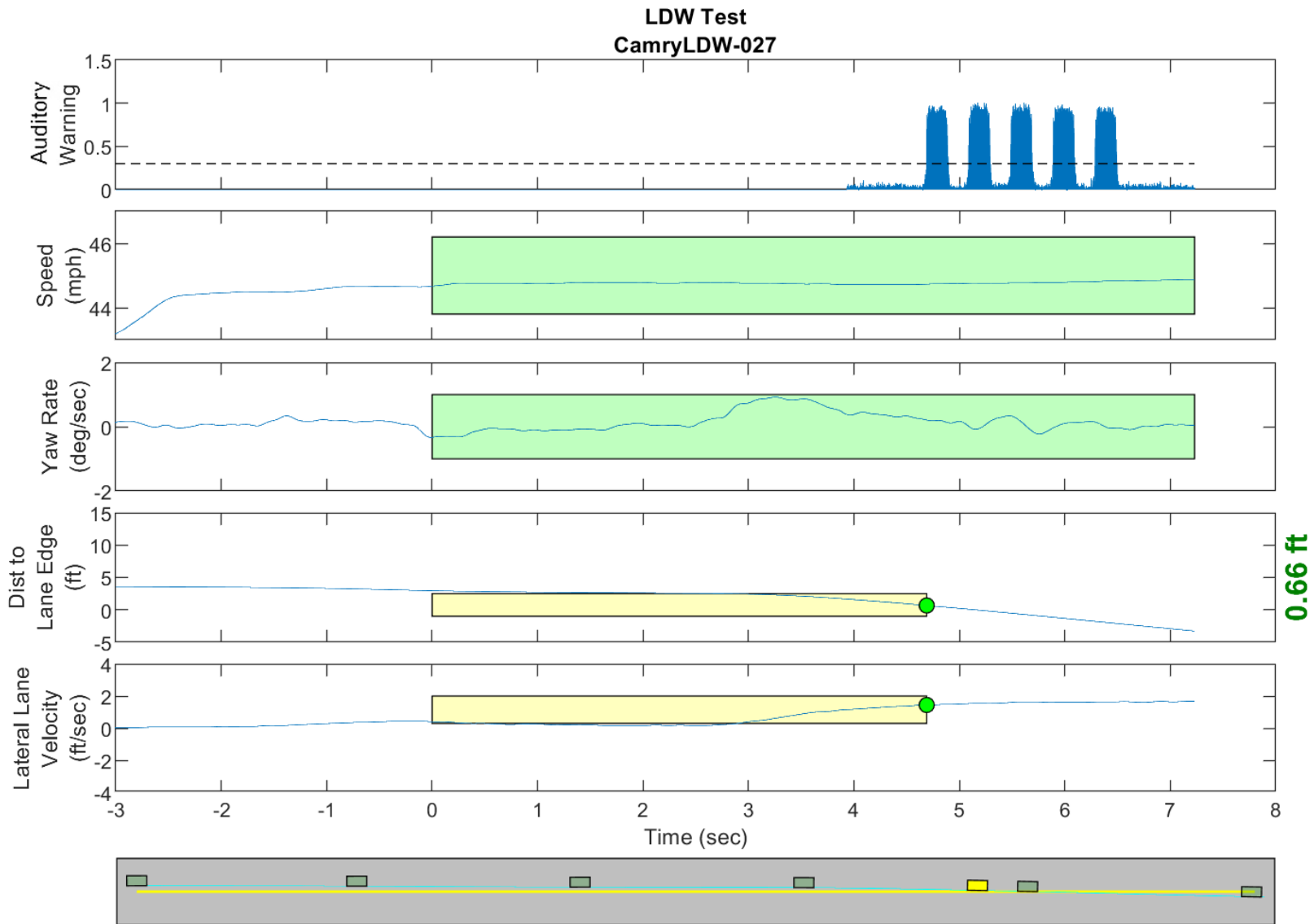

GPS Fix Type: RTK Fixed

Figure D44. Time History for Run 27, Solid Line, Right Departure, Auditory Warning

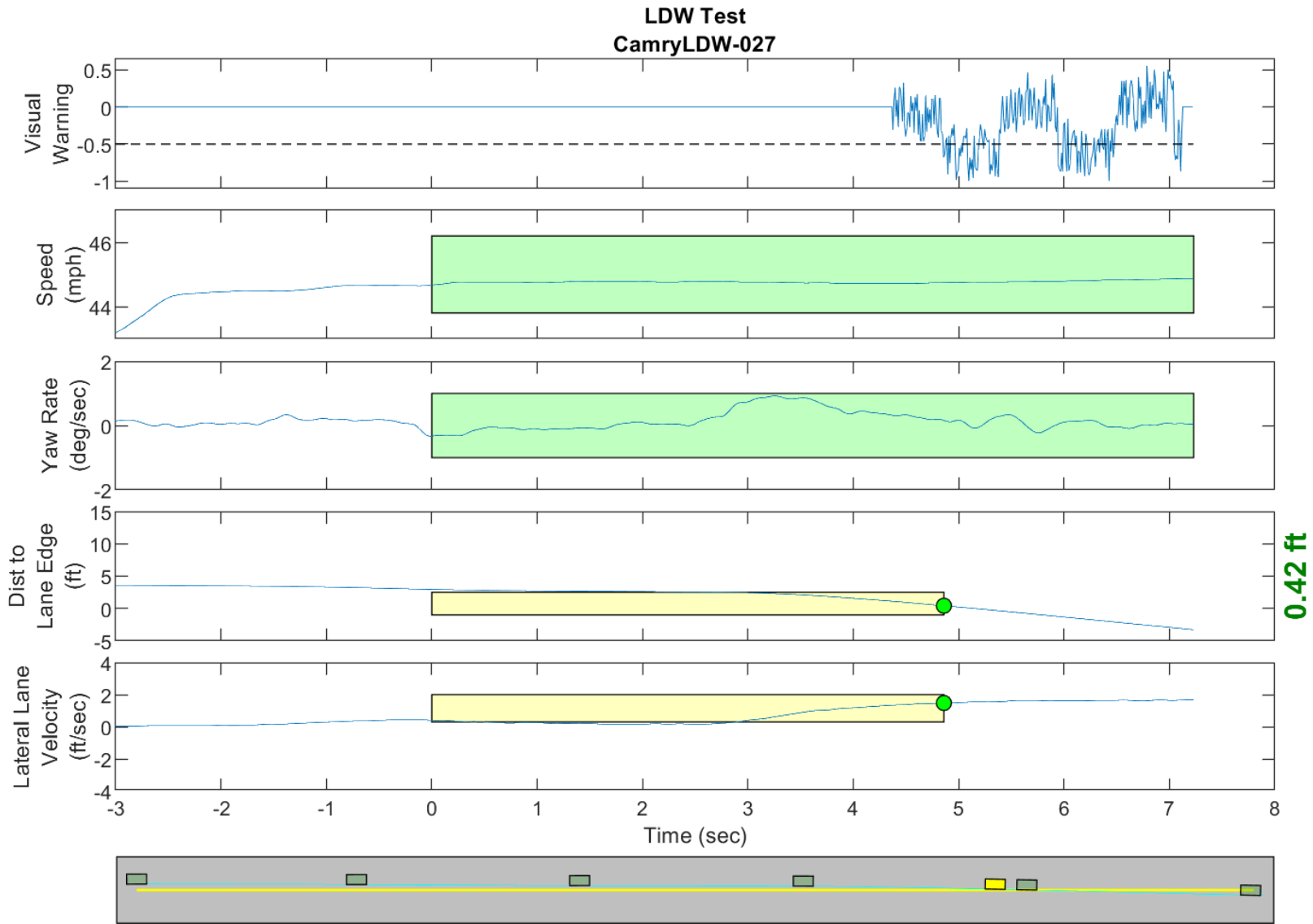

GPS Fix Type: RTK Fixed

Figure D45. Time History for Run 27, Solid Line, Right Departure, Visual Warning

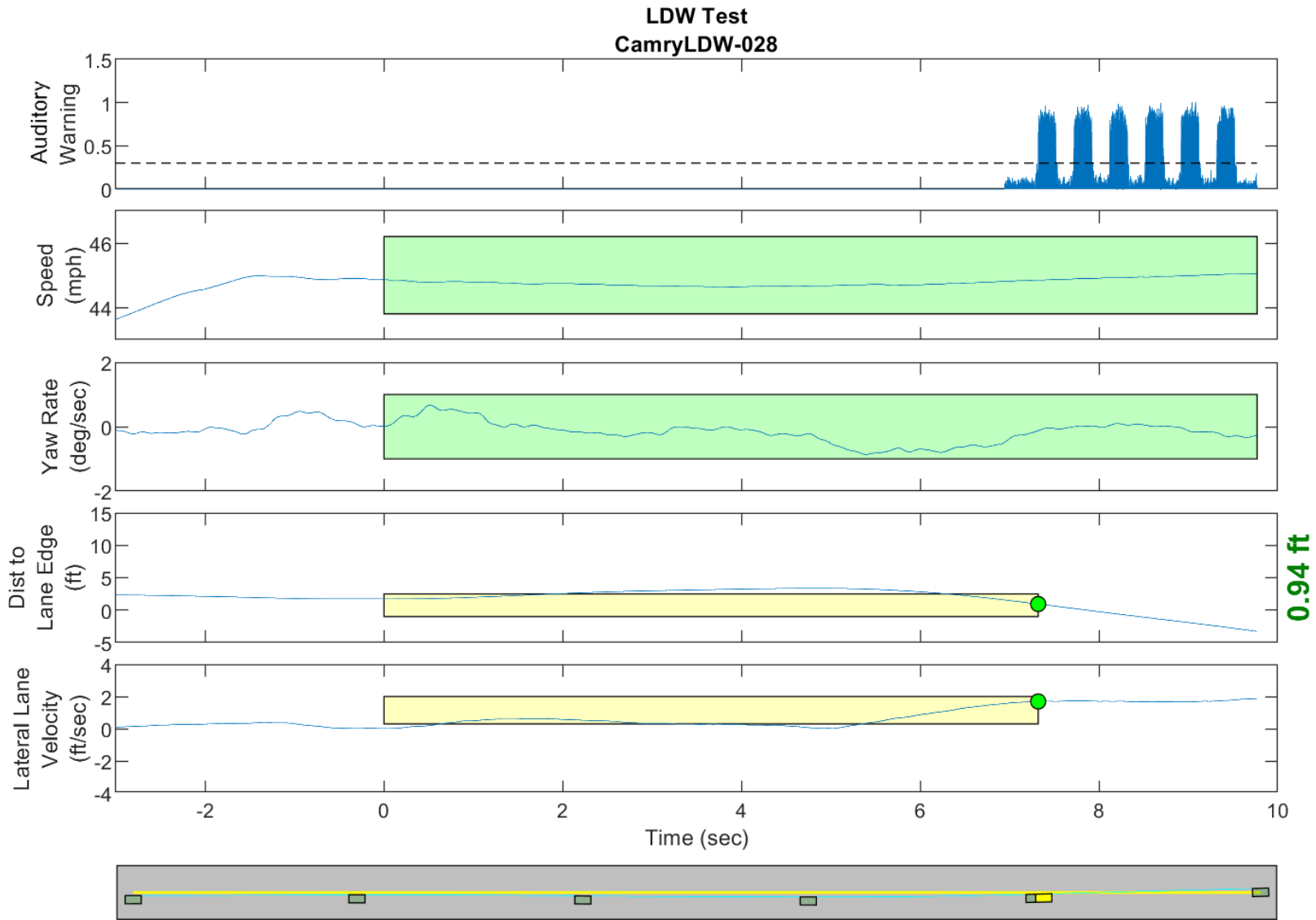

GPS Fix Type: RTK Fixed

Figure D46. Time History for Run 28, Solid Line, Left Departure, Auditory Warning

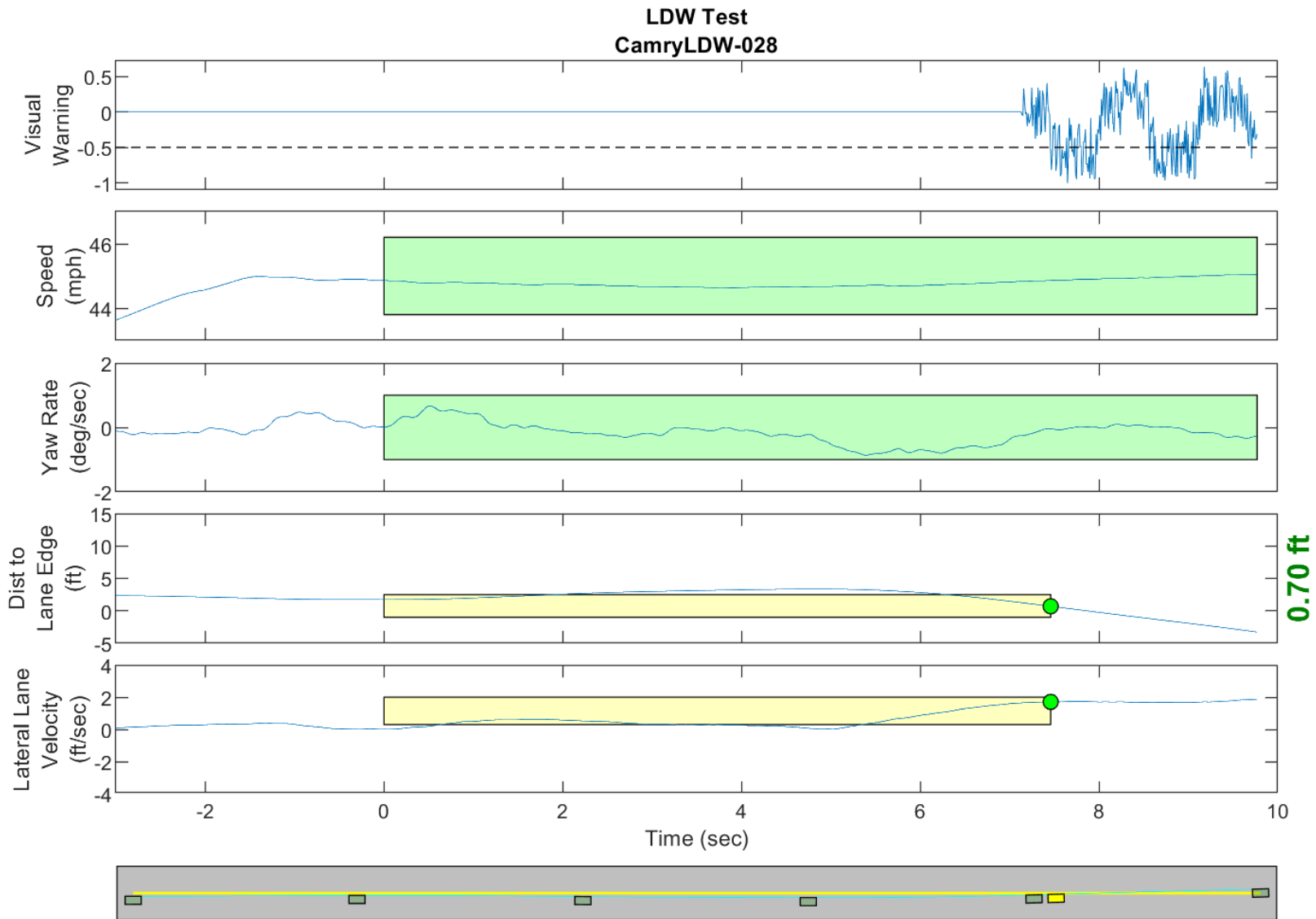

GPS Fix Type: RTK Fixed

Figure D47. Time History for Run 28, Solid Line, Left Departure, Visual Warning

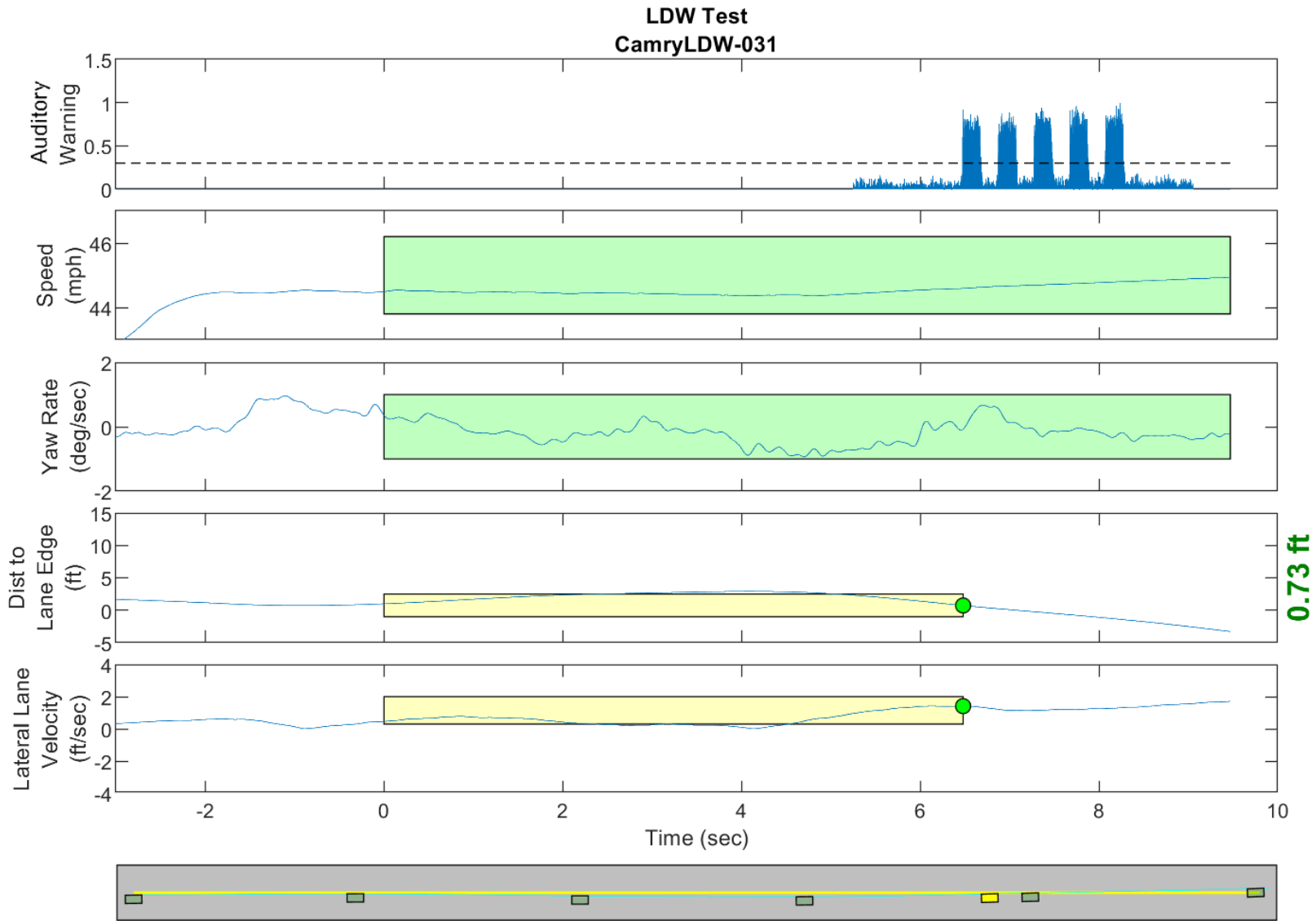

GPS Fix Type: RTK Fixed

Figure D48. Time History for Run 31, Solid Line, Left Departure, Auditory Warning

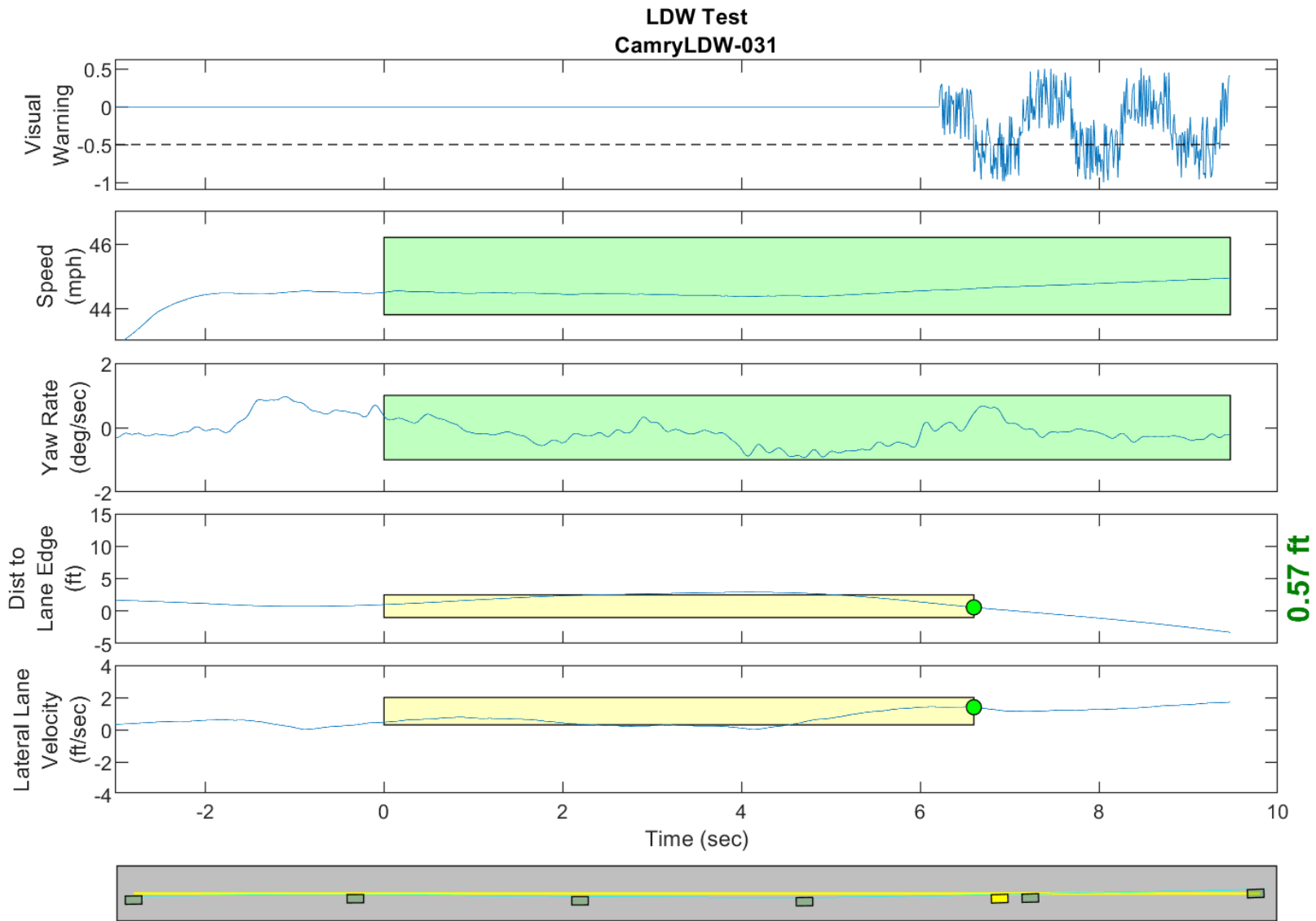

GPS Fix Type: RTK Fixed

Figure D49. Time History for Run 31, Solid Line, Left Departure, Visual Warning

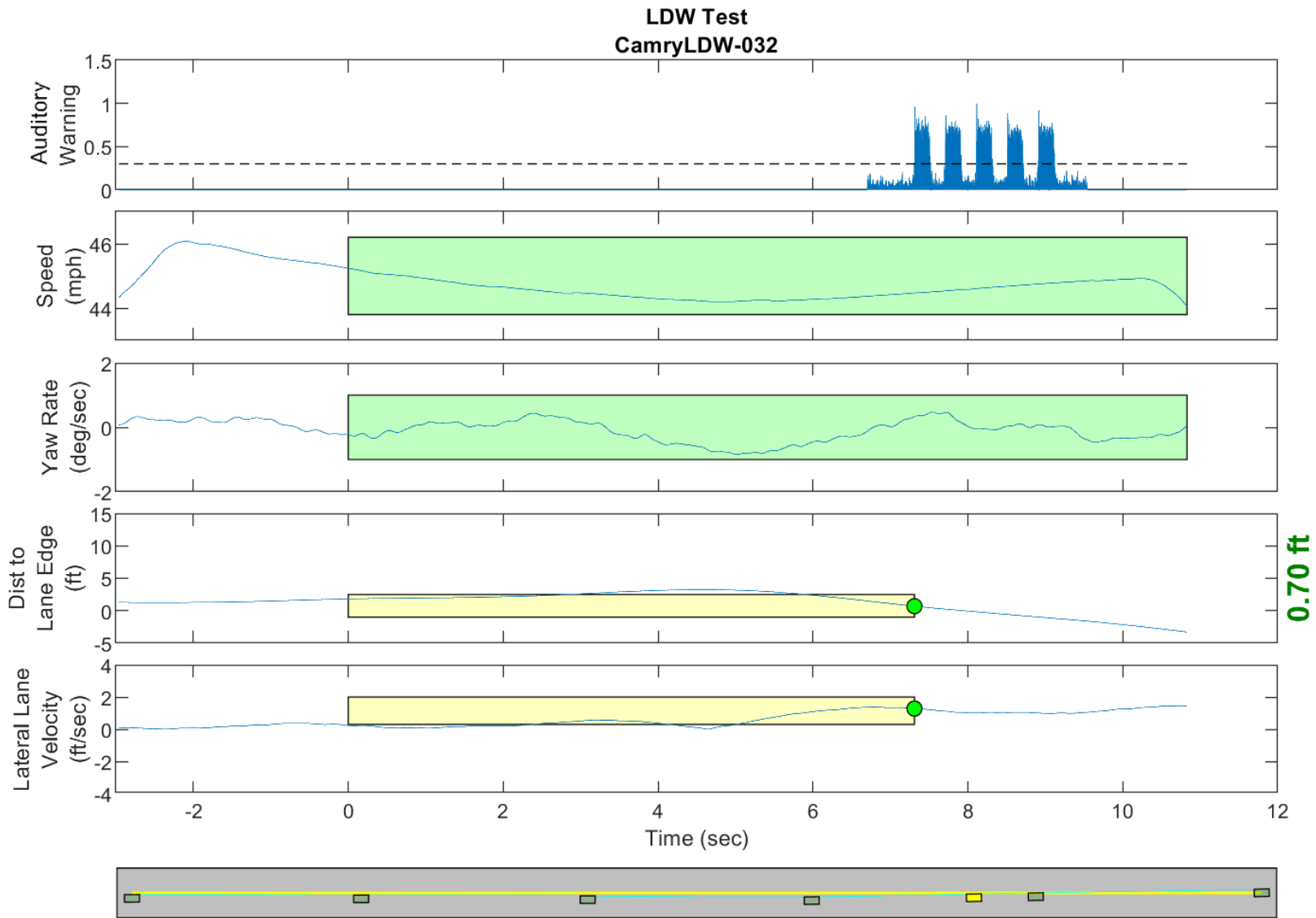

GPS Fix Type: RTK Fixed

Figure D50. Time History for Run 32, Solid Line, Left Departure, Auditory Warning

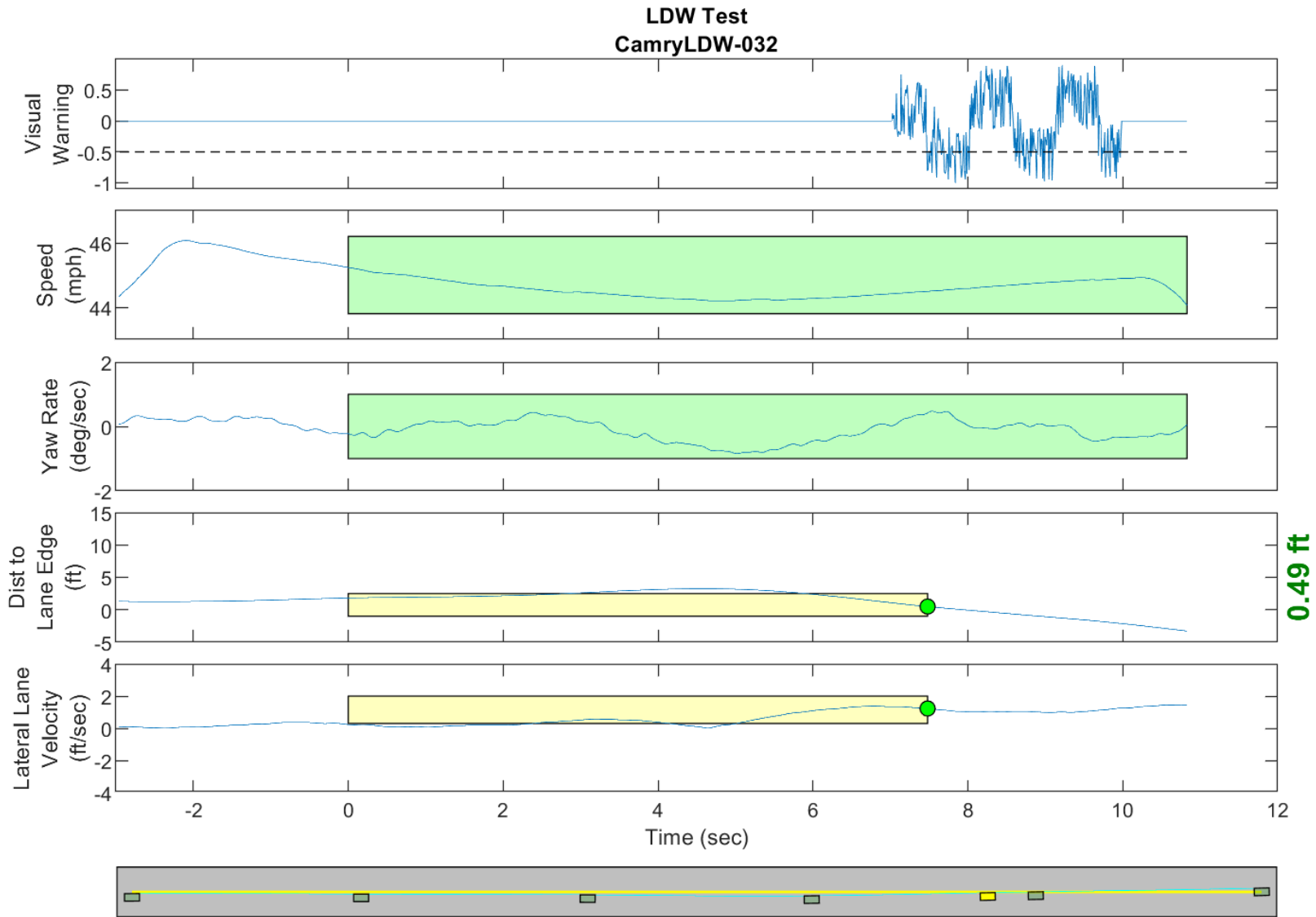

GPS Fix Type: RTK Fixed

Figure D51. Time History for Run 32, Solid Line, Left Departure, Visual Warning

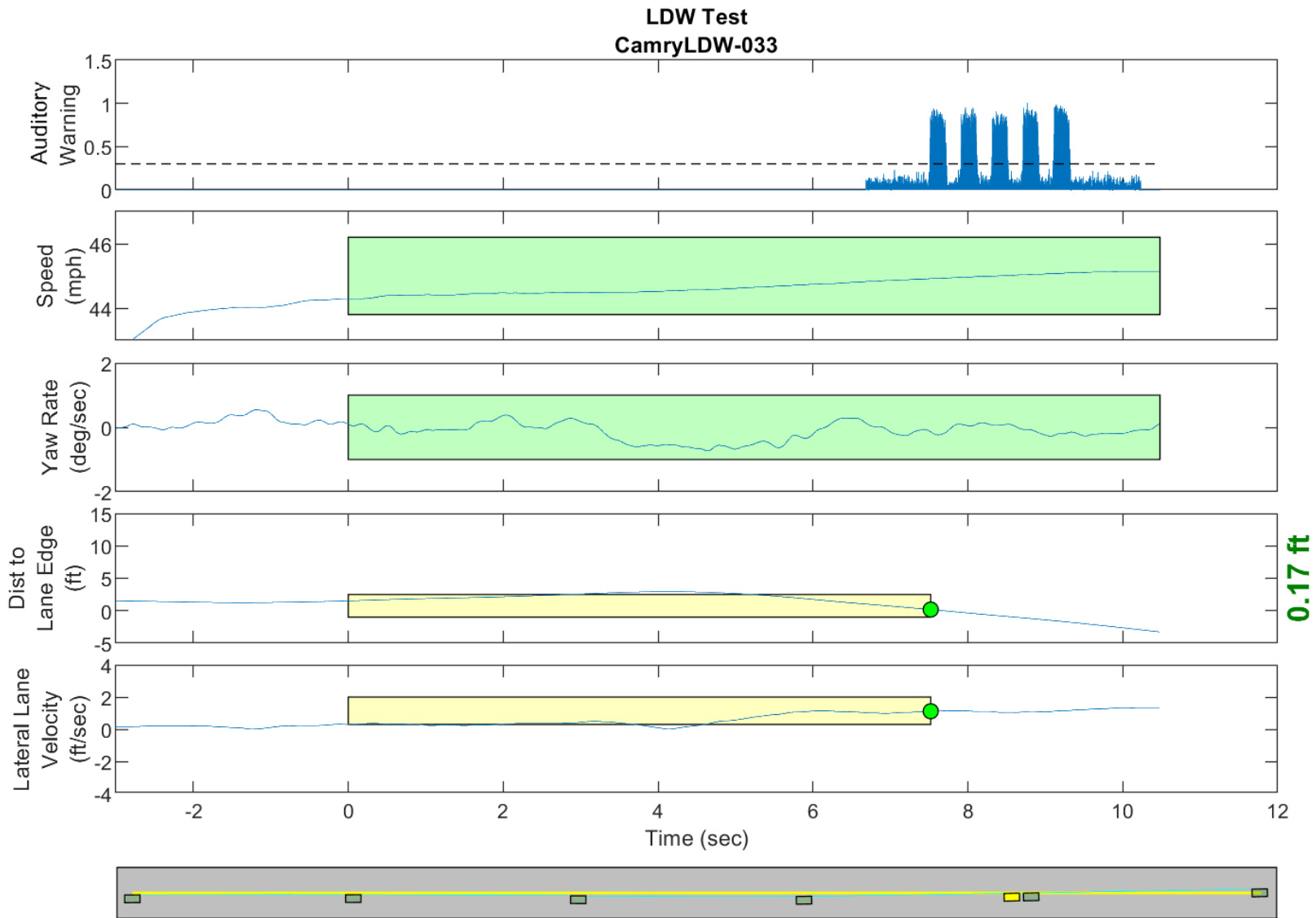

GPS Fix Type: RTK Fixed

Figure D52. Time History for Run 33, Solid Line, Left Departure, Auditory Warning

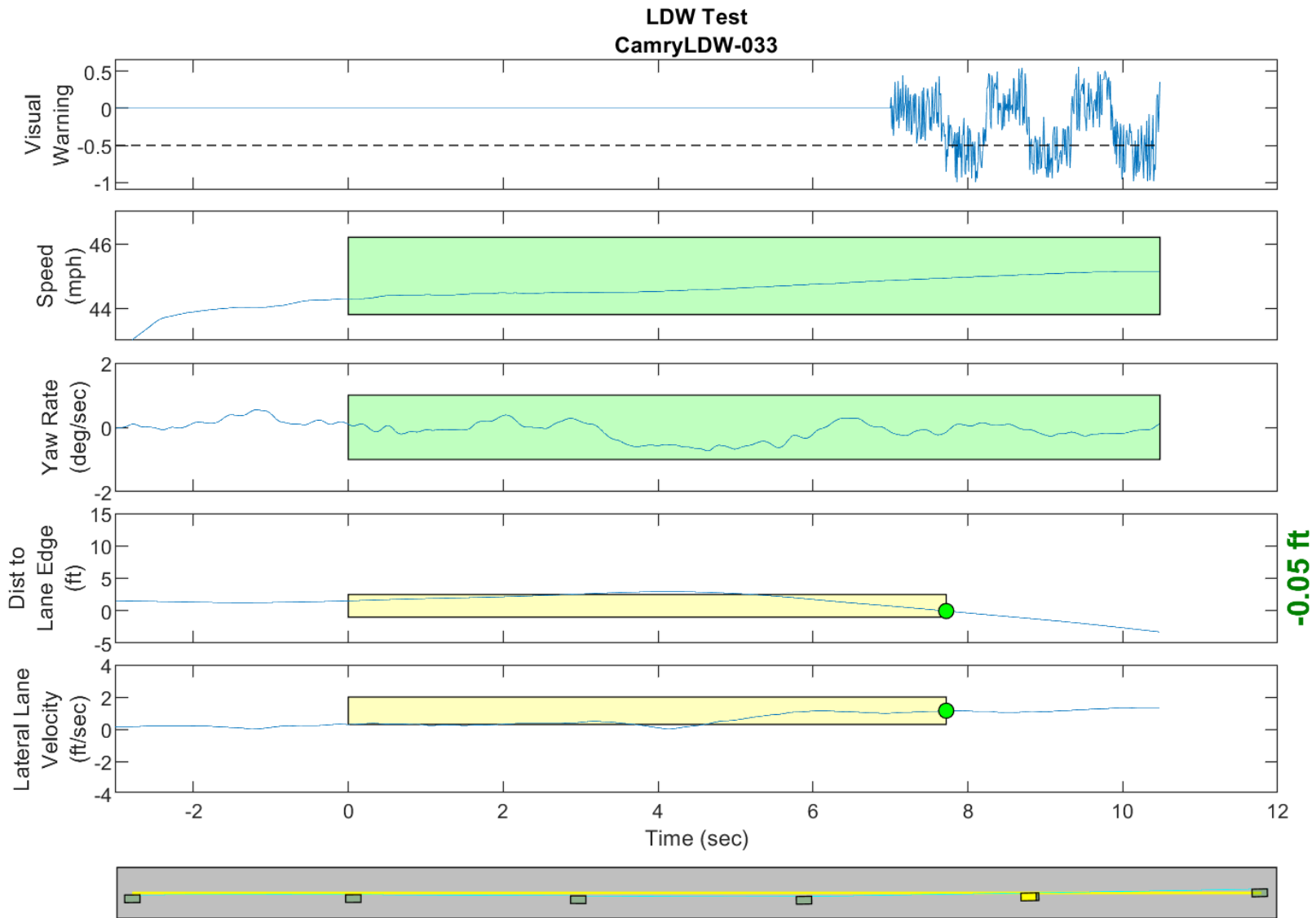

GPS Fix Type: RTK Fixed

Figure D53. Time History for Run 33, Solid Line, Left Departure, Visual Warning

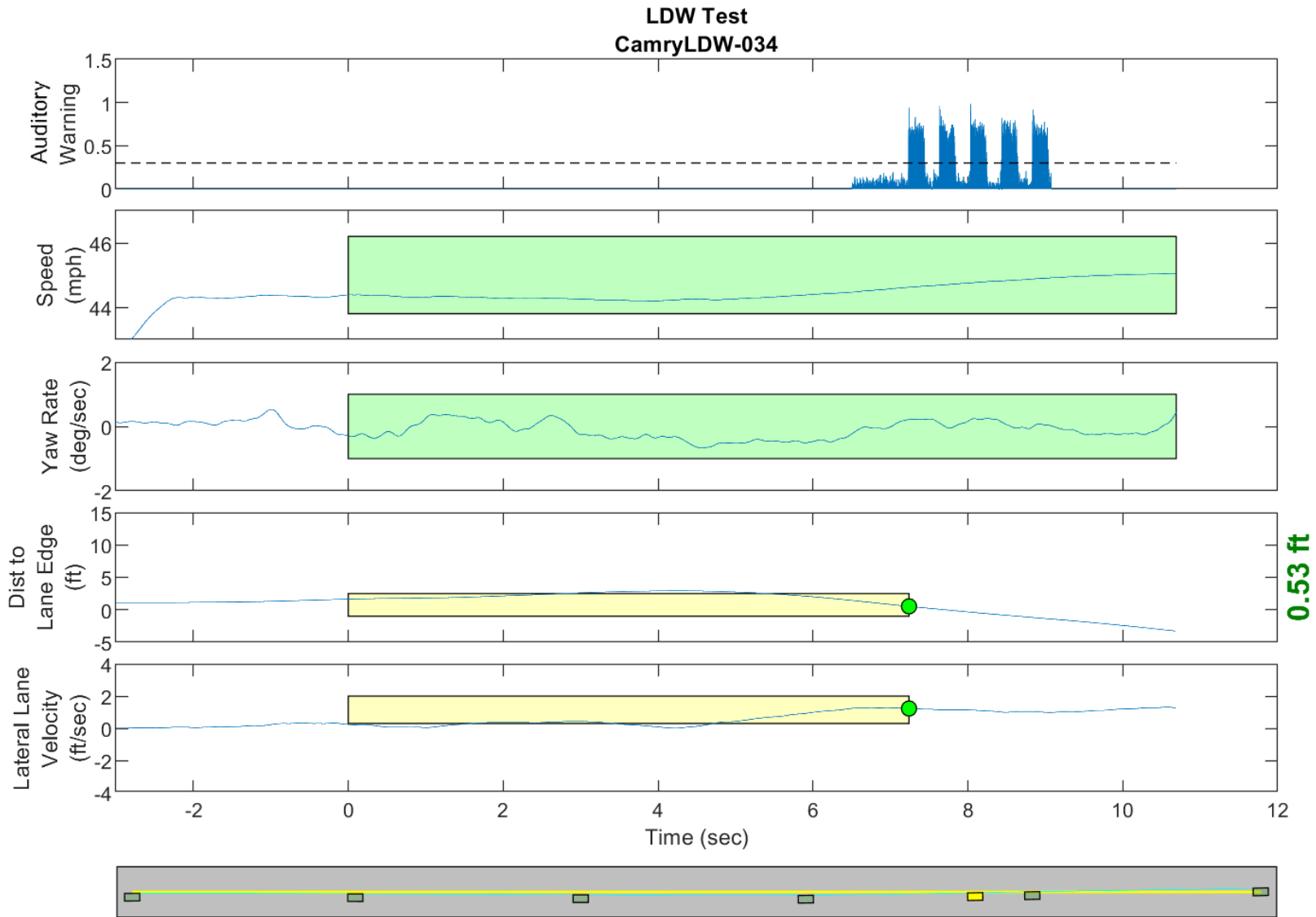

GPS Fix Type: RTK Fixed

Figure D54. Time History for Run 34, Solid Line, Left Departure, Auditory Warning

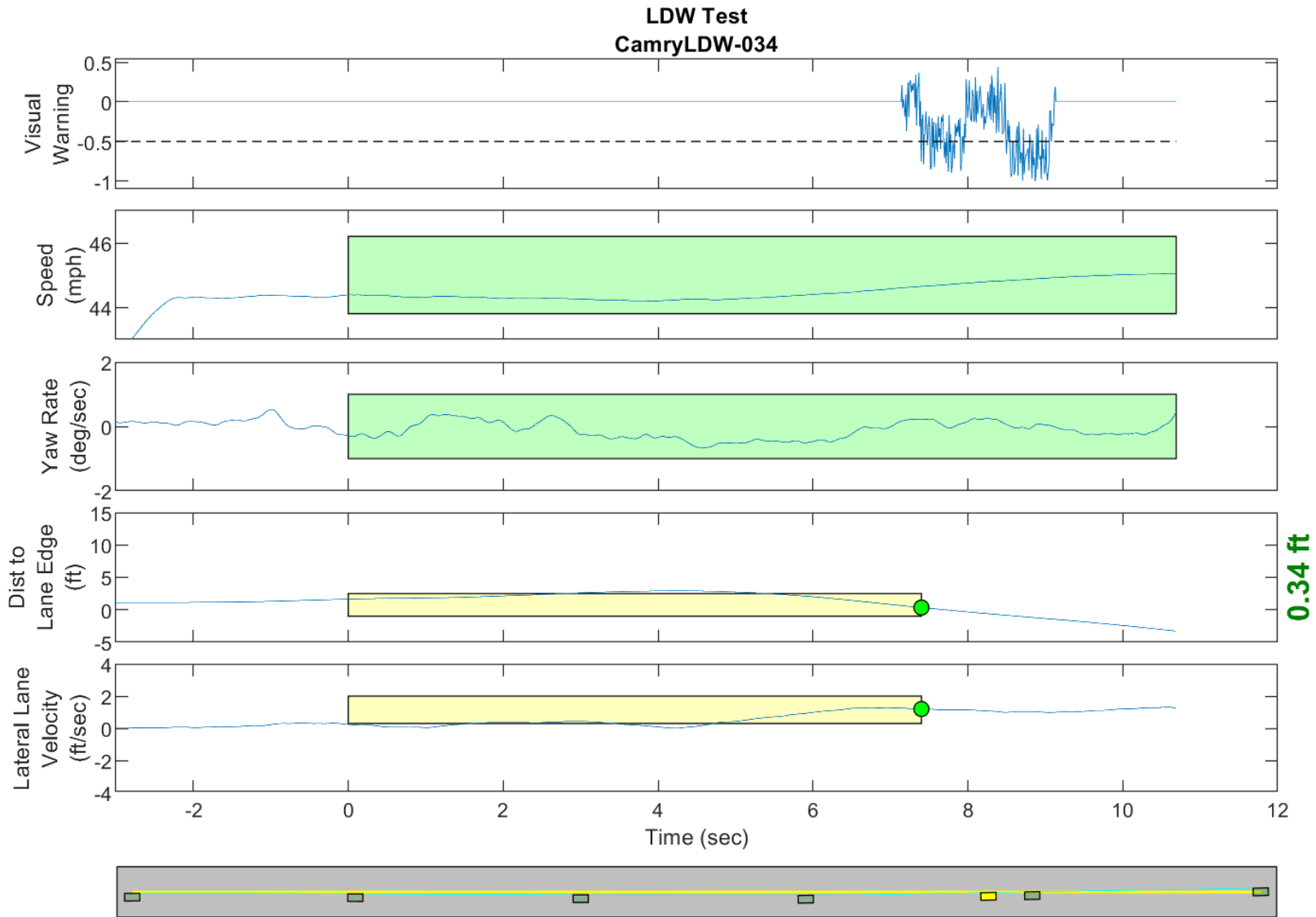

GPS Fix Type: RTK Fixed

Figure D55. Time History for Run 34, Solid Line, Left Departure, Visual Warning

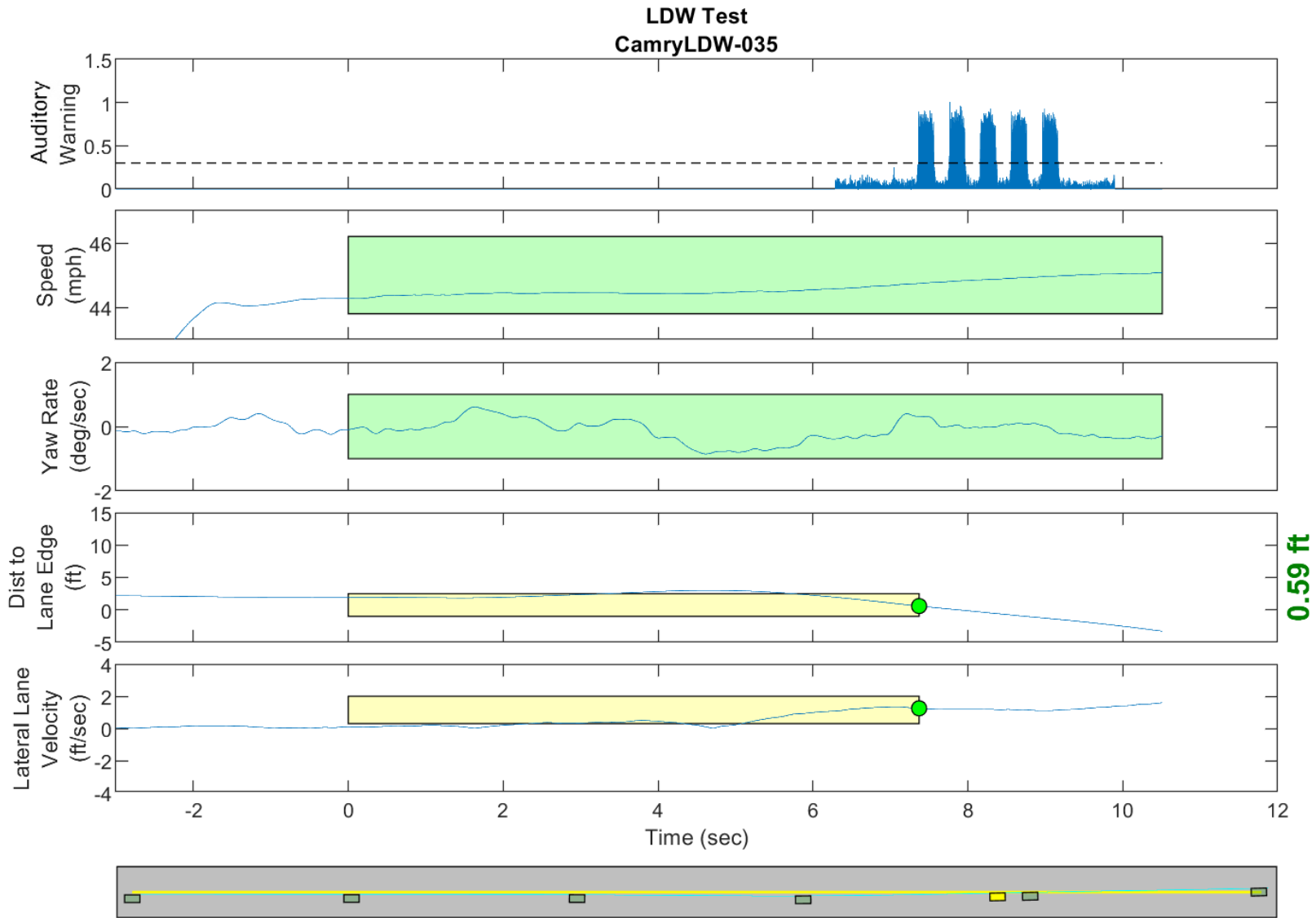

GPS Fix Type: RTK Fixed

Figure D56. Time History for Run 35, Solid Line, Left Departure, Auditory Warning

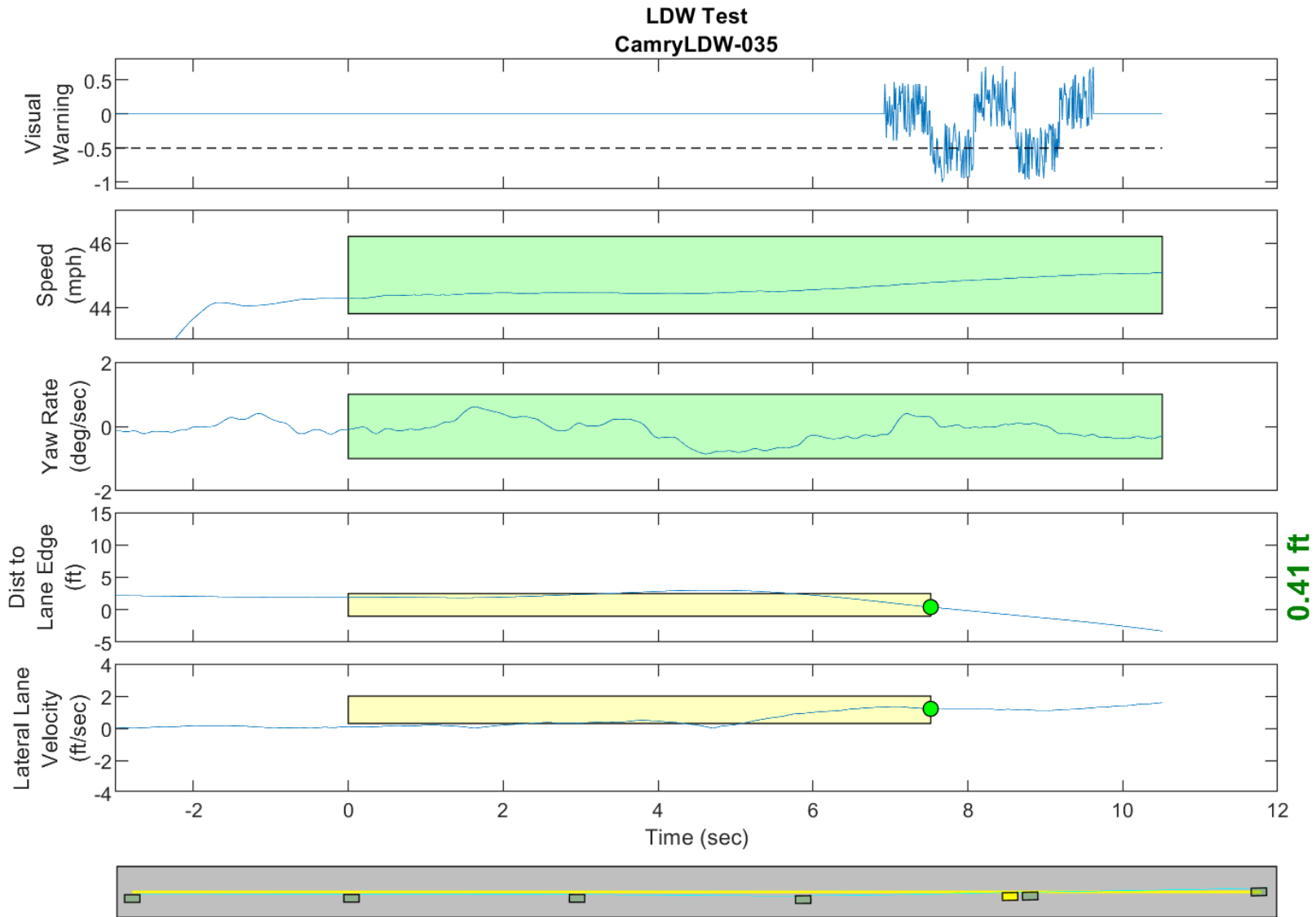

GPS Fix Type: RTK Fixed

Figure D57. Time History for Run 35, Solid Line, Left Departure, Visual Warning

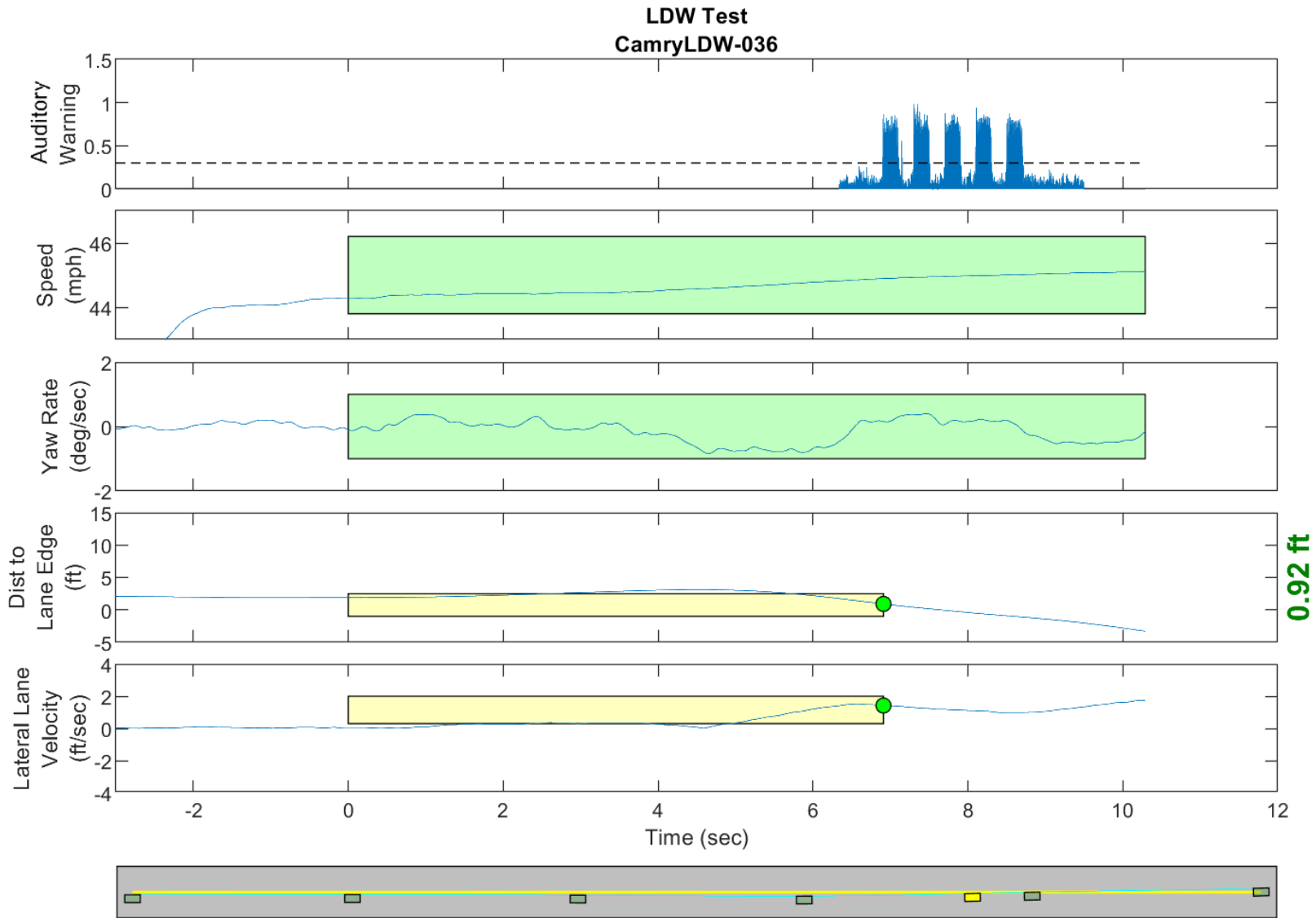

GPS Fix Type: RTK Fixed

Figure D58. Time History for Run 36, Solid Line, Left Departure, Auditory Warning

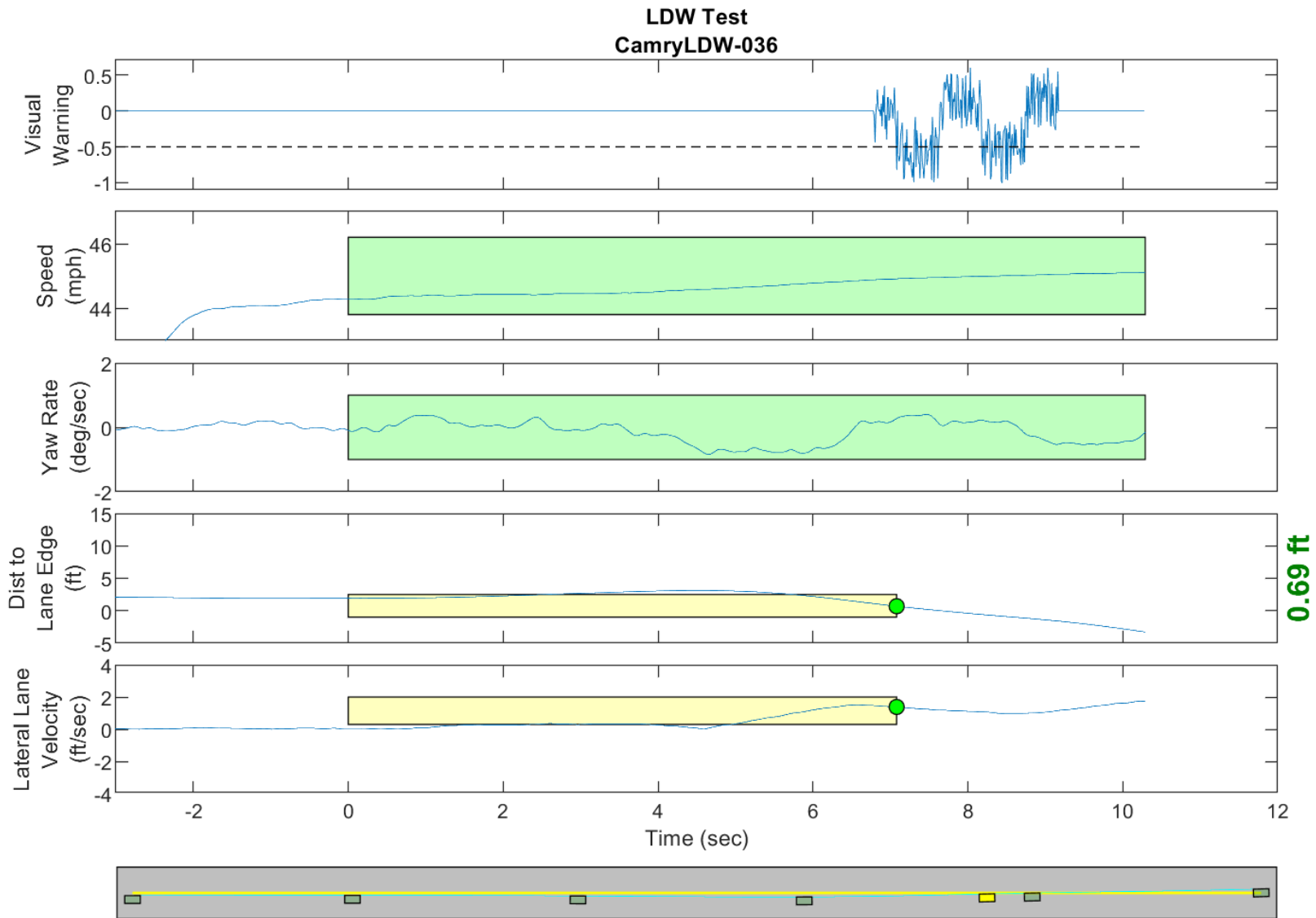

GPS Fix Type: RTK Fixed

Figure D59. Time History for Run 36, Solid Line, Left Departure, Visual Warning

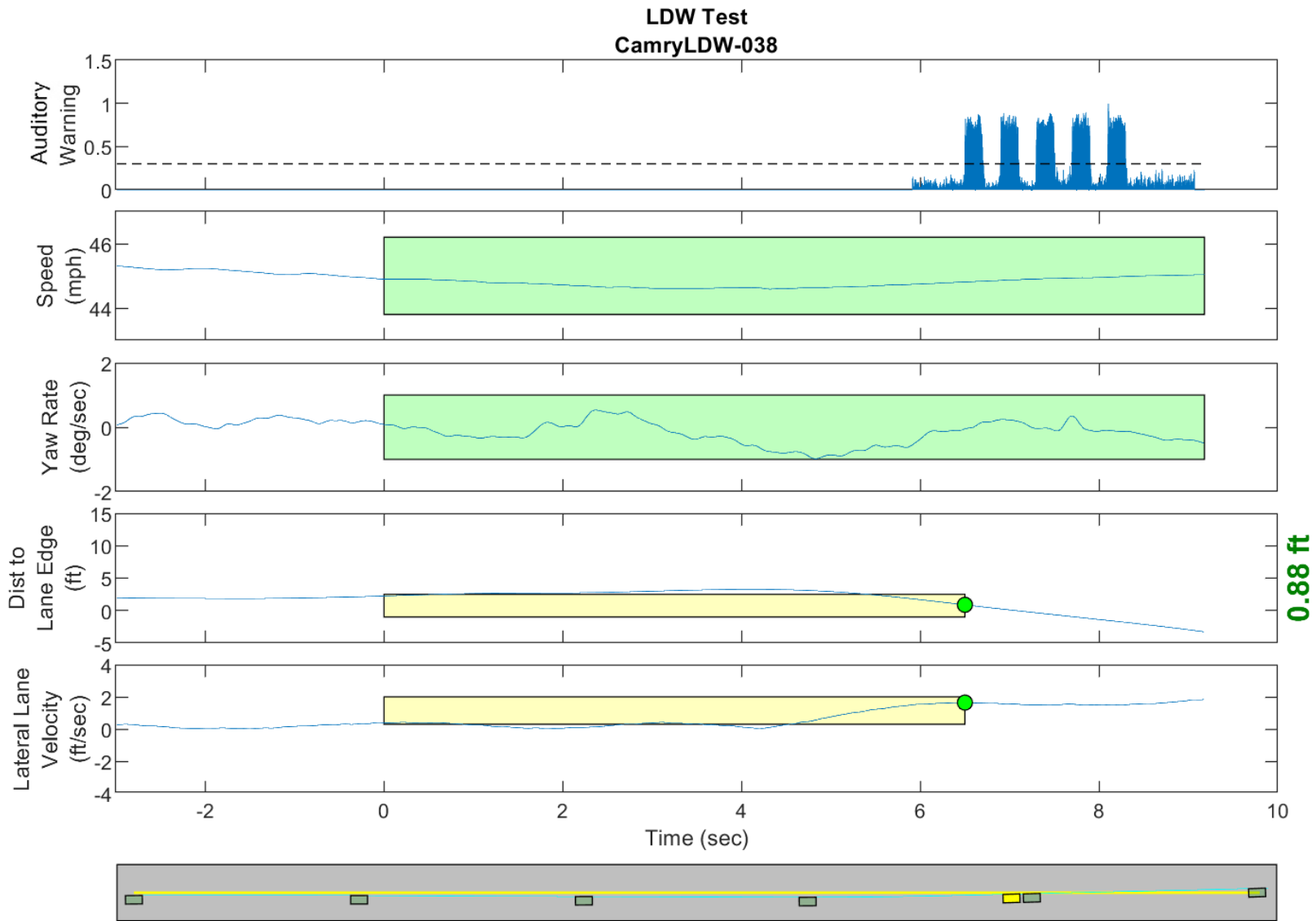

GPS Fix Type: RTK Fixed

Figure D60. Time History for Run 38, Botts Dots, Left Departure, Auditory Warning

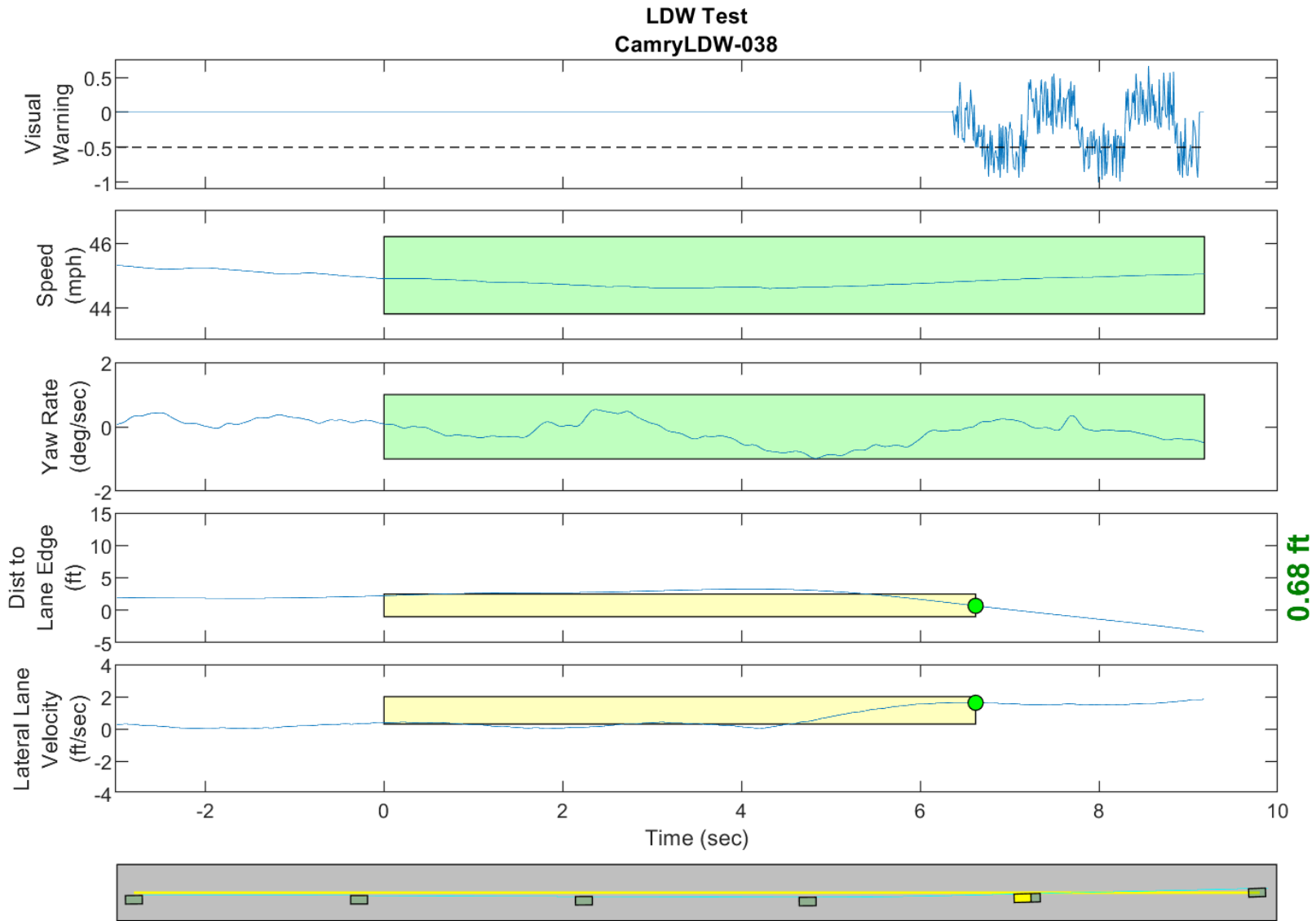

GPS Fix Type: RTK Fixed

Figure D61. Time History for Run 38, Botts Dots, Left Departure, Visual Warning

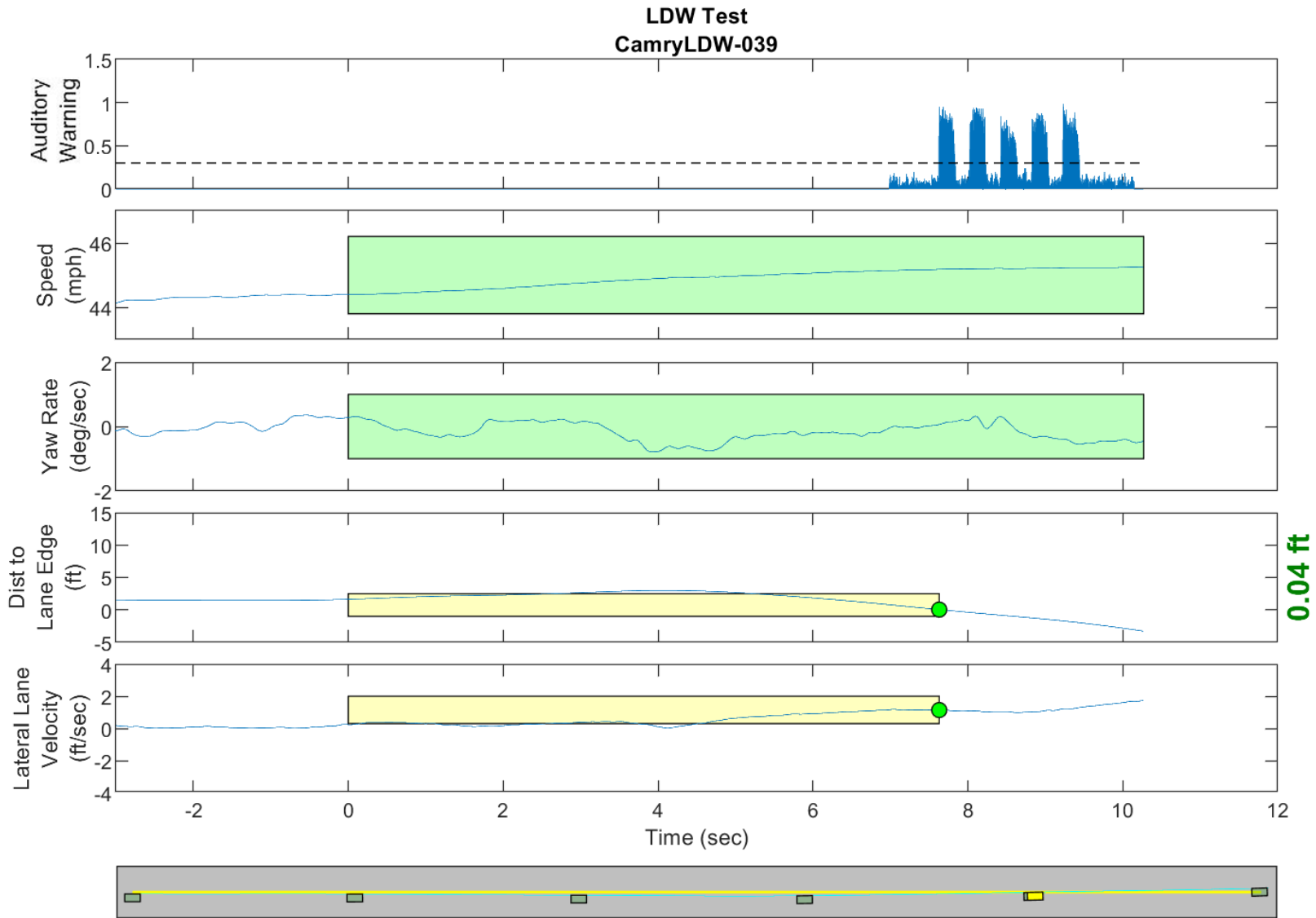

GPS Fix Type: RTK Fixed

Figure D62. Time History for Run 39, Botts Dots, Left Departure, Auditory Warning

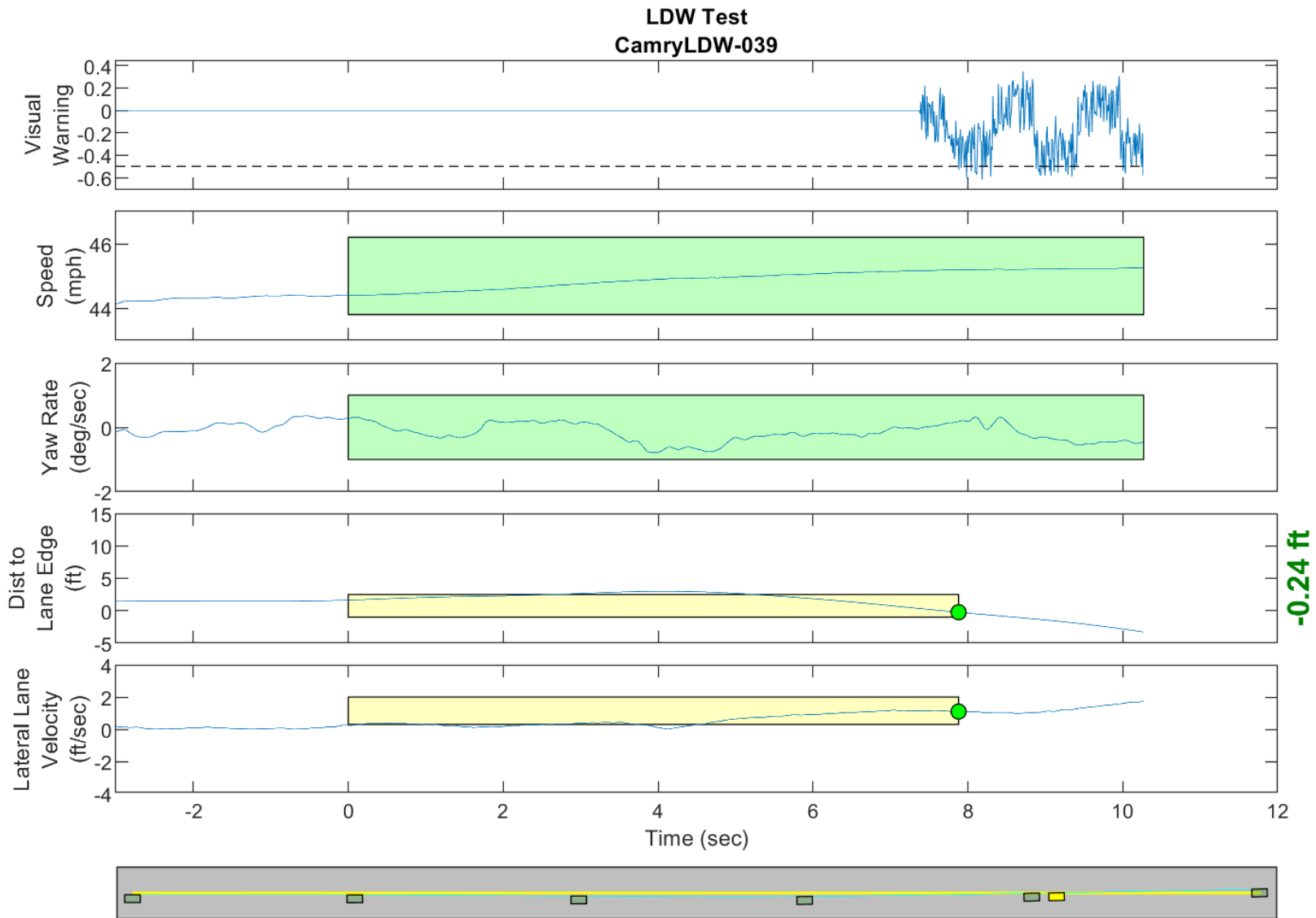

GPS Fix Type: RTK Fixed

Figure D63. Time History for Run 39, Botts Dots, Left Departure, Visual Warning

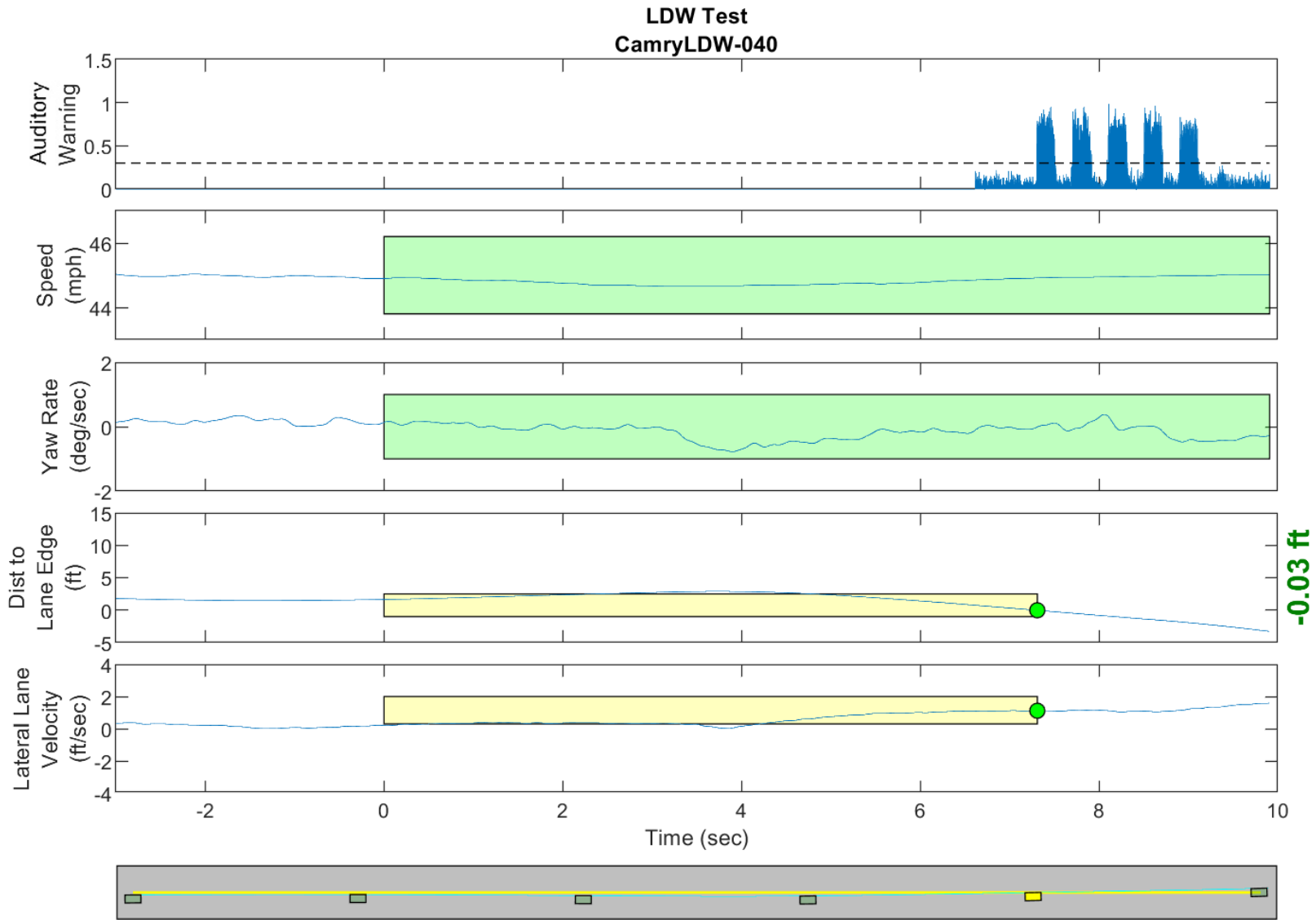

GPS Fix Type: RTK Fixed

Figure D64. Time History for Run 40, Botts Dots, Left Departure, Auditory Warning

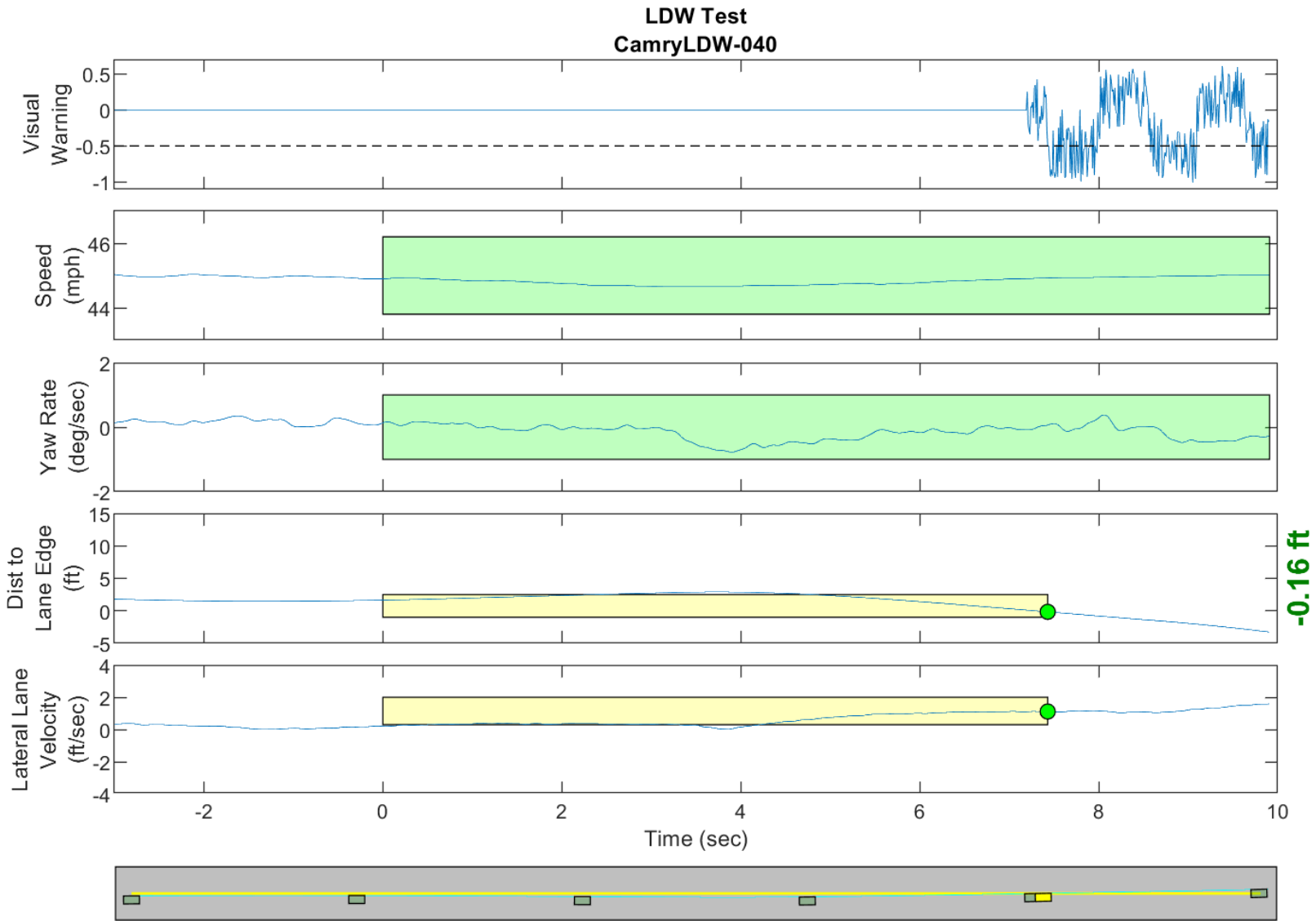

GPS Fix Type: RTK Fixed

Figure D65. Time History for Run 40, Botts Dots, Left Departure, Visual Warning

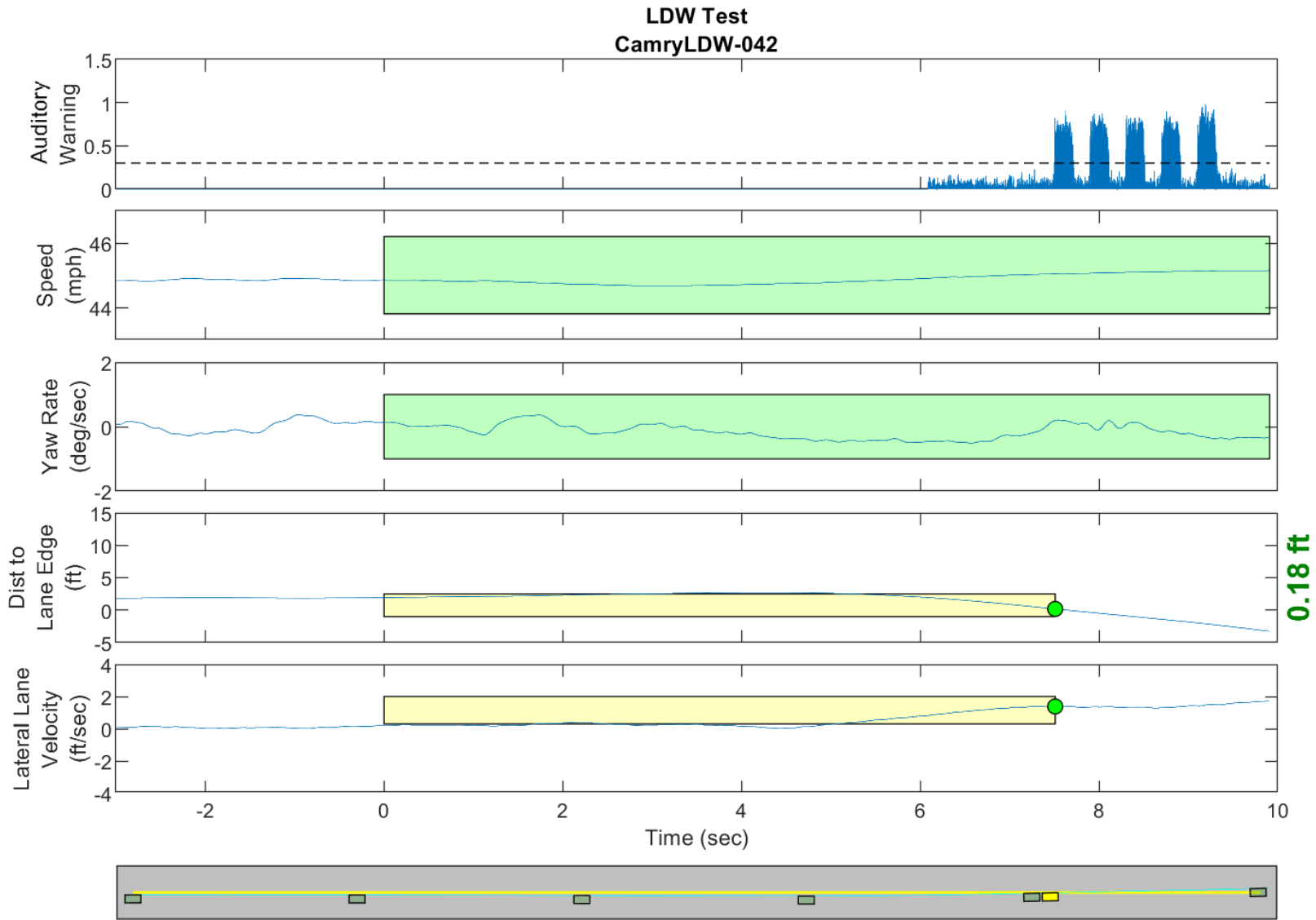

GPS Fix Type: RTK Fixed

Figure D66. Time History for Run 42, Botts Dots, Left Departure, Auditory Warning

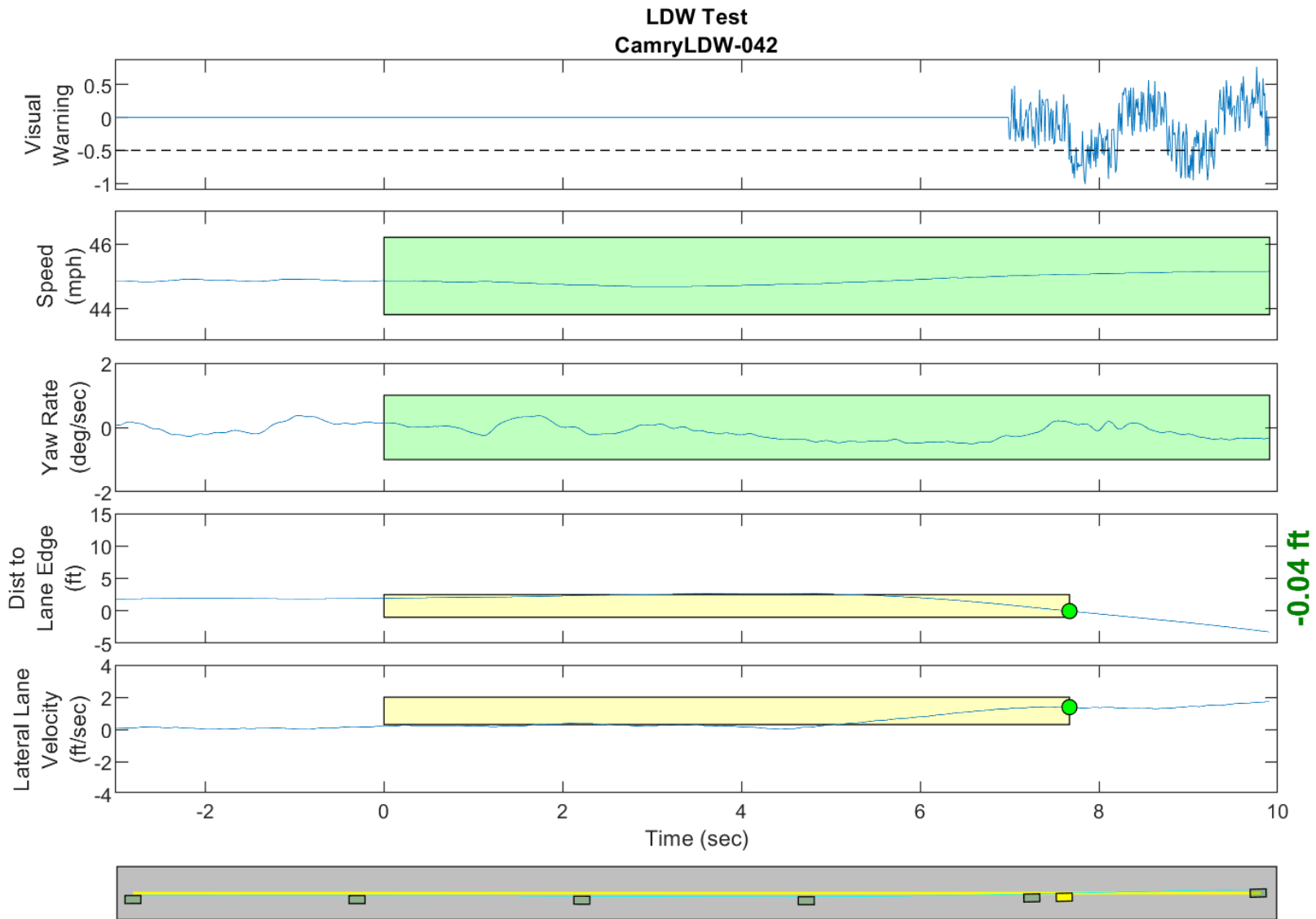

GPS Fix Type: RTK Fixed

Figure D67. Time History for Run 42, Botts Dots, Left Departure, Visual Warning

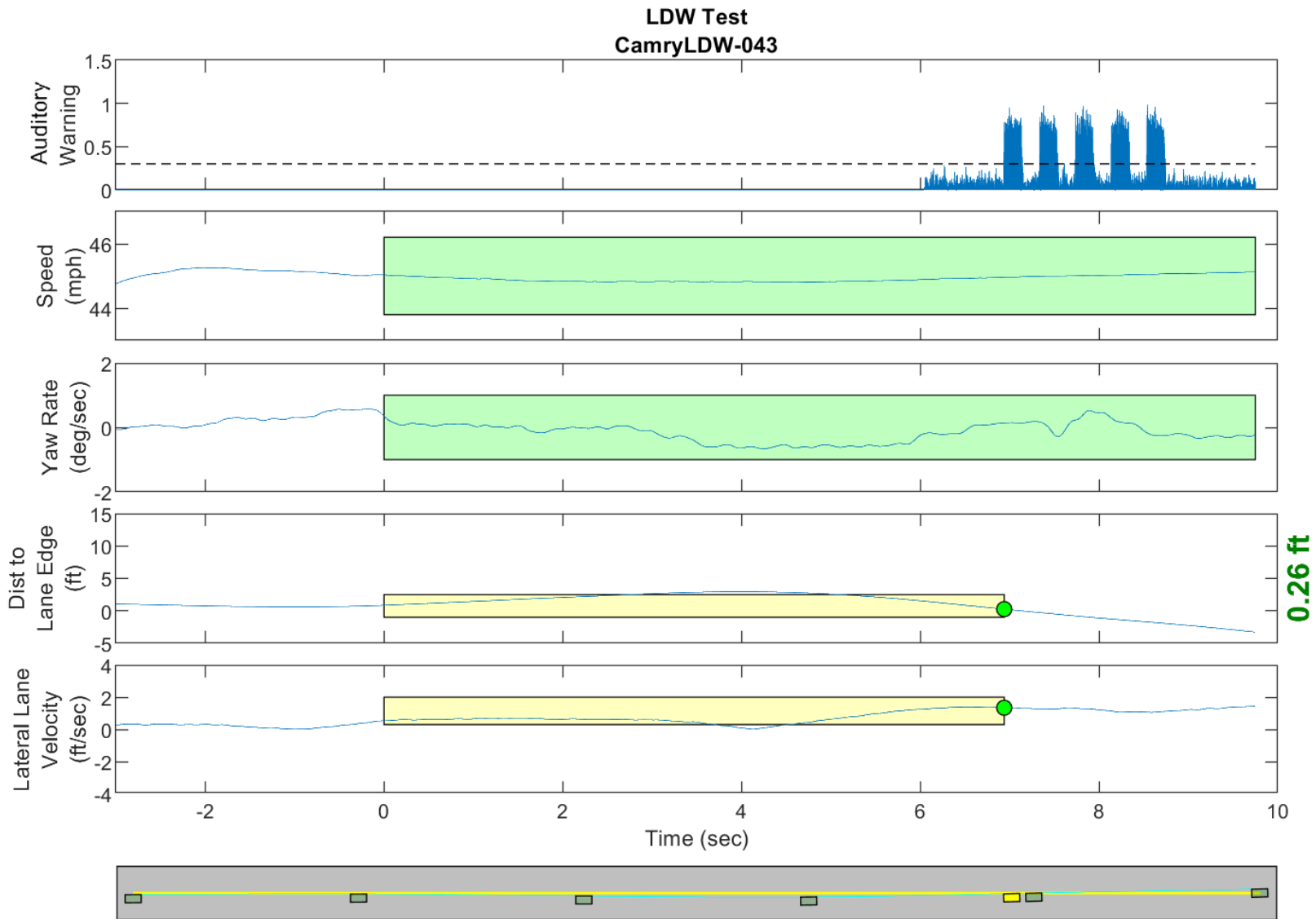

GPS Fix Type: RTK Fixed

Figure D68. Time History for Run 43, Botts Dots, Left Departure, Auditory Warning

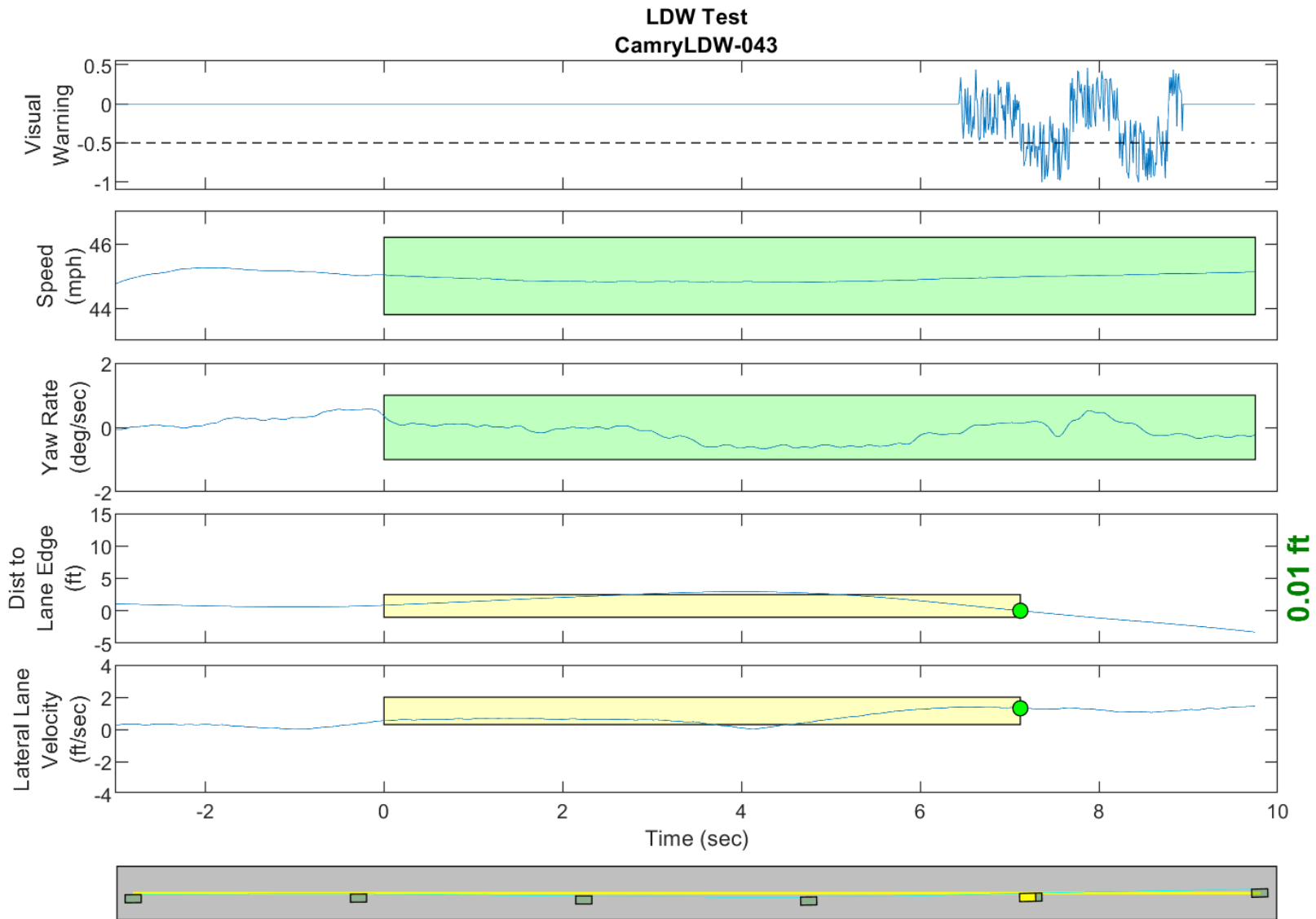

GPS Fix Type: RTK Fixed

Figure D69. Time History for Run 43, Botts Dots, Left Departure, Visual Warning

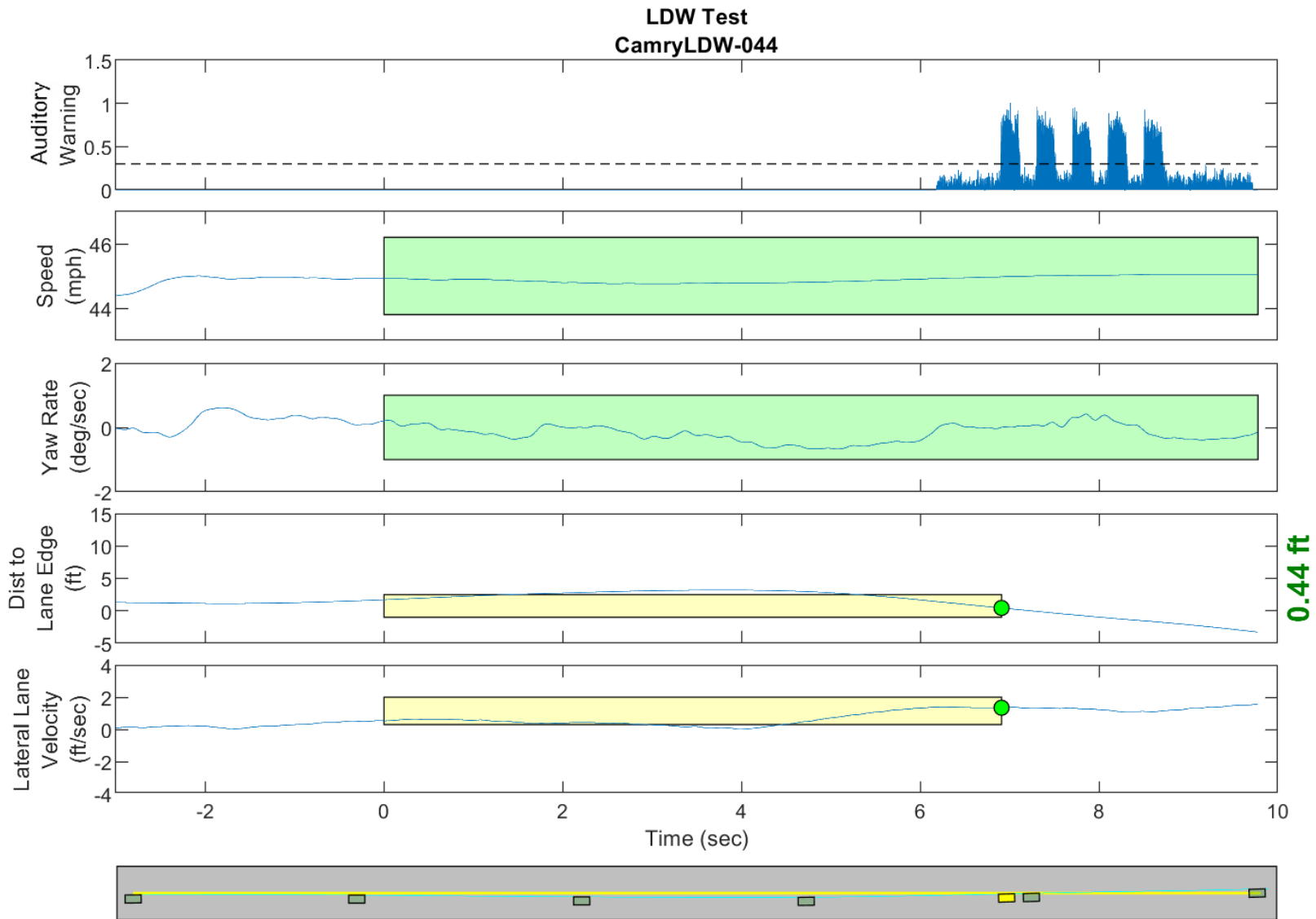

GPS Fix Type: RTK Fixed

Figure D70. Time History for Run 44, Botts Dots, Left Departure, Auditory Warning

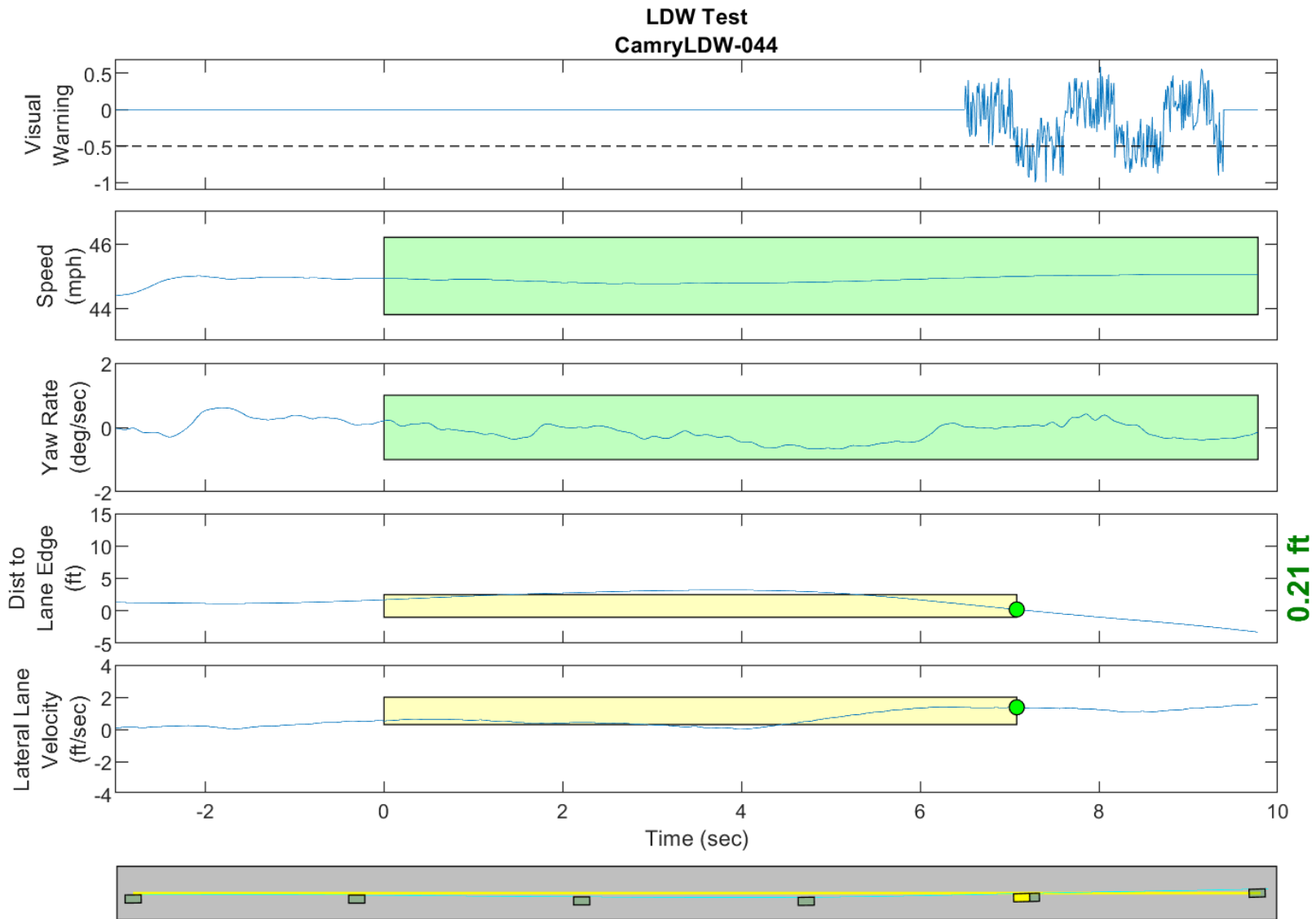

GPS Fix Type: RTK Fixed

Figure D71. Time History for Run 44, Botts Dots, Left Departure, Visual Warning

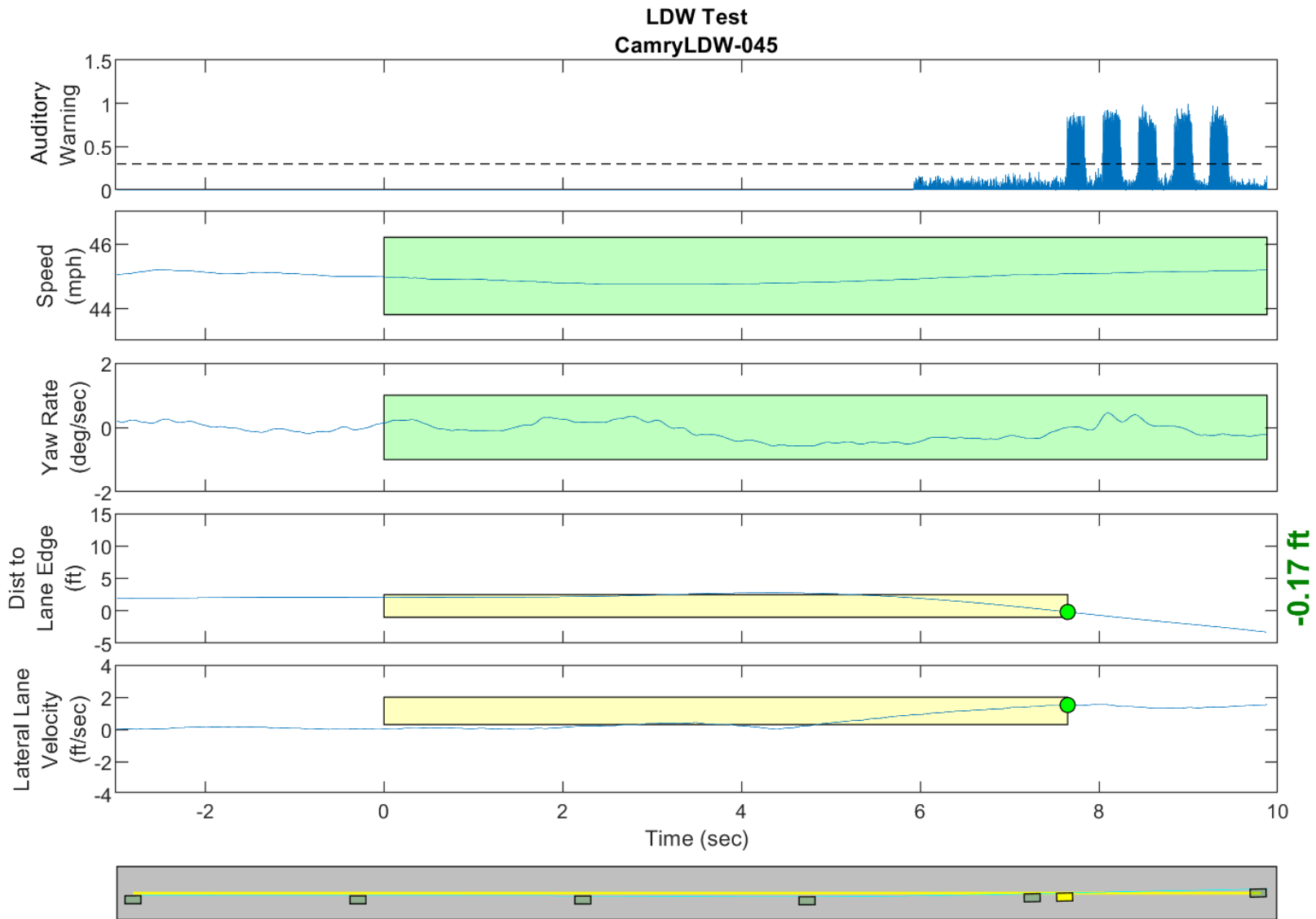

GPS Fix Type: RTK Fixed

Figure D72. Time History for Run 45, Botts Dots, Left Departure, Auditory Warning

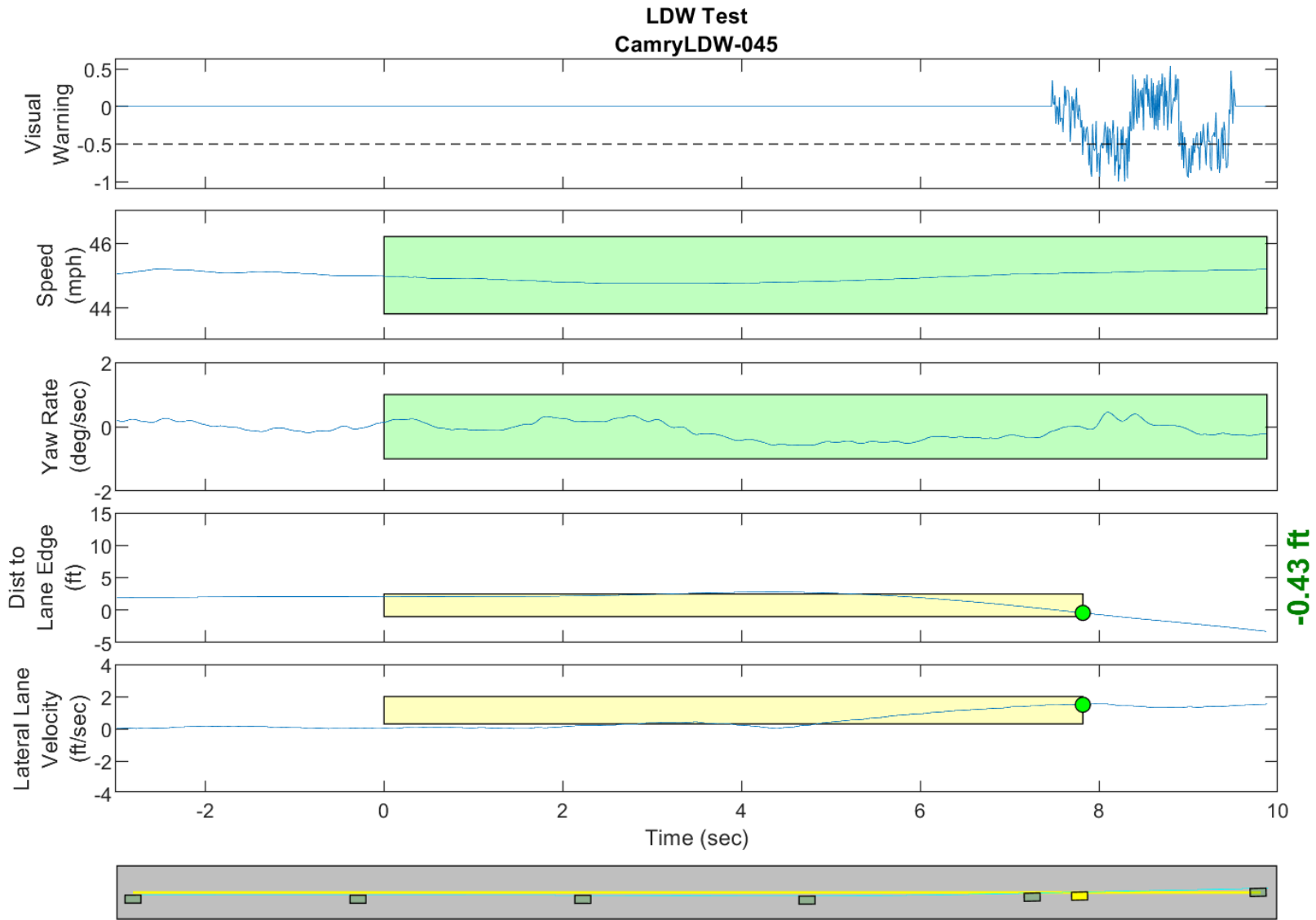

GPS Fix Type: RTK Fixed

Figure D73. Time History for Run 45, Botts Dots, Left Departure, Visual Warning

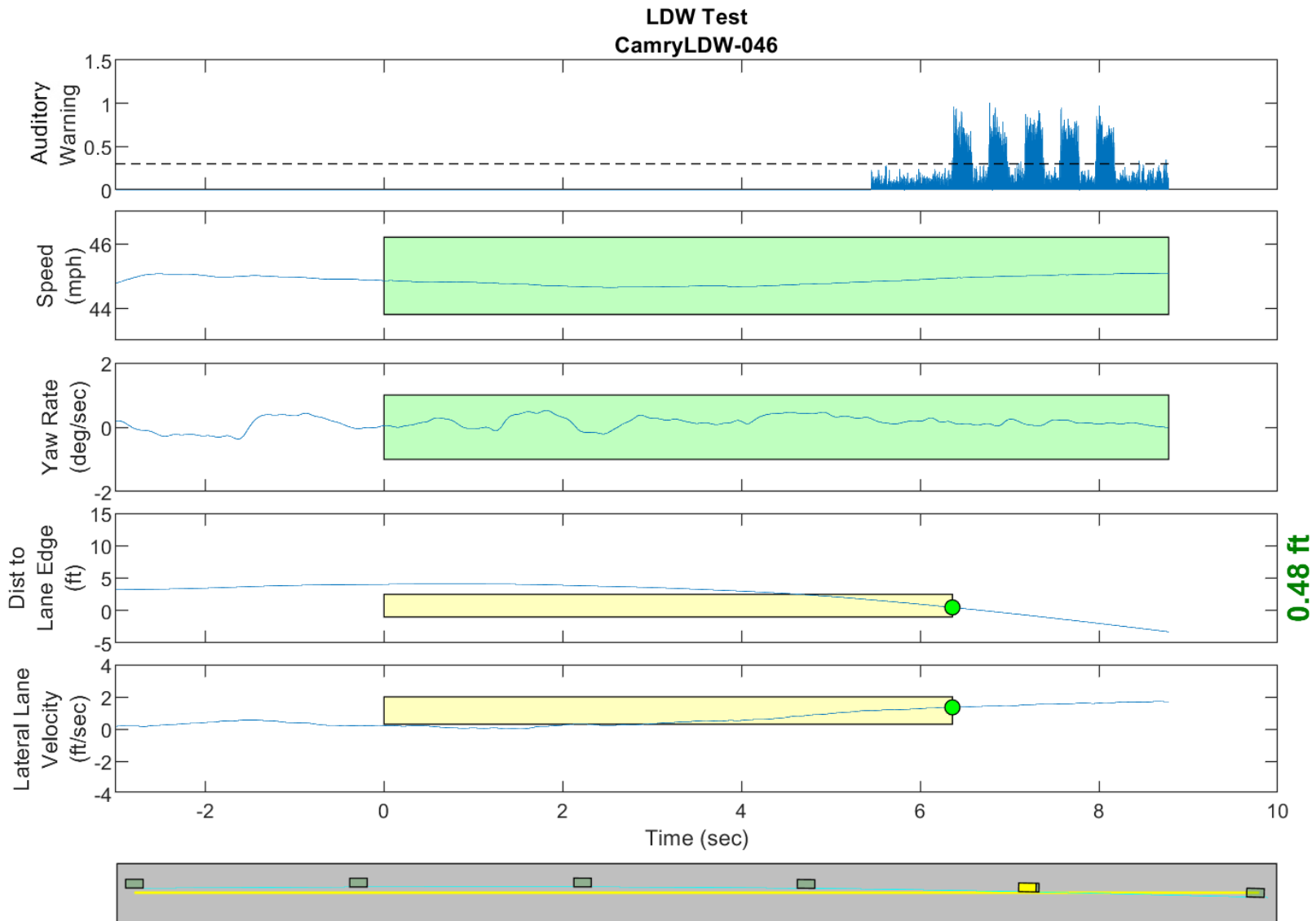

GPS Fix Type: RTK Fixed

Figure D74. Time History for Run 46, Botts Dots, Right Departure, Auditory Warning

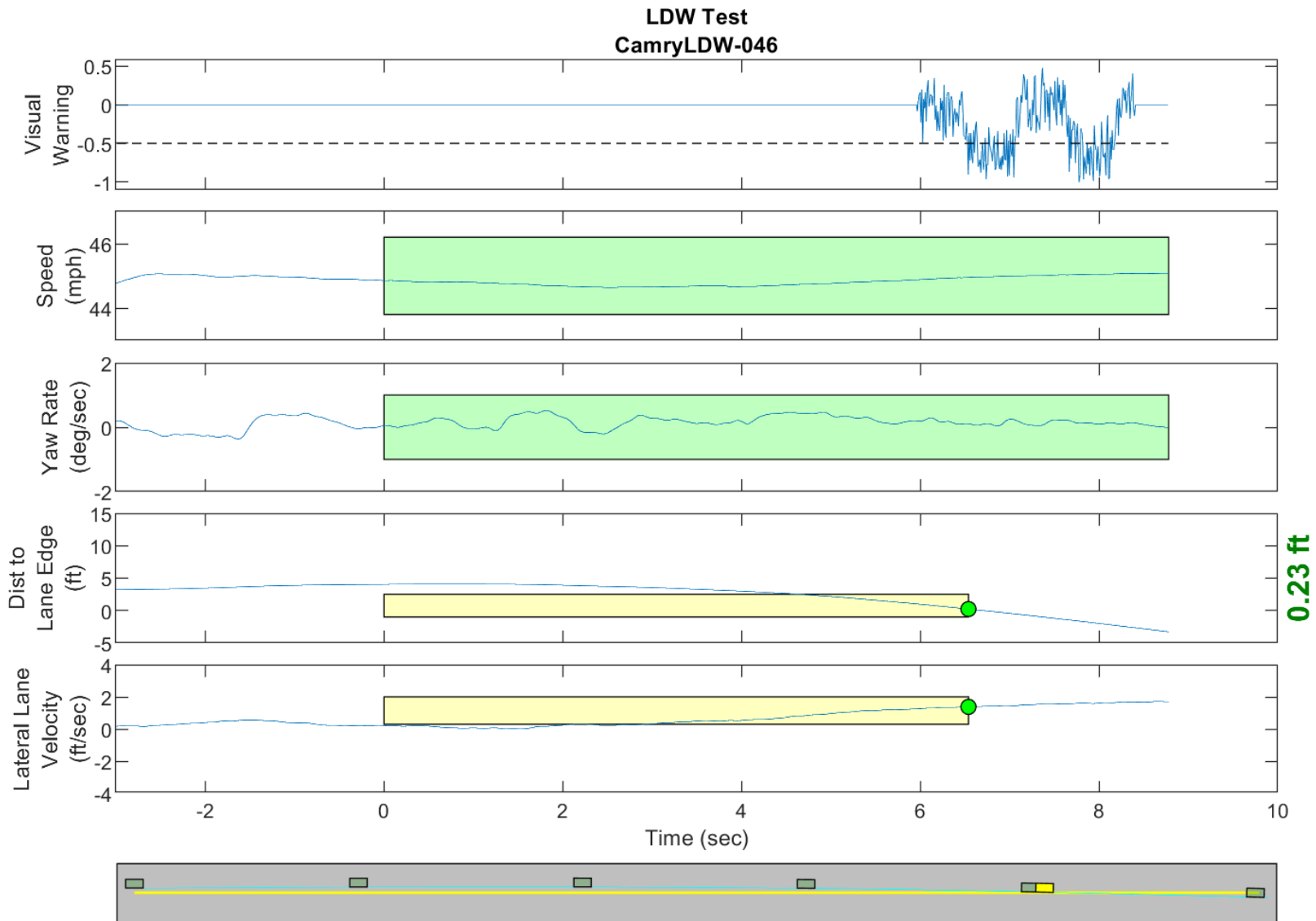

GPS Fix Type: RTK Fixed

Figure D75. Time History for Run 46, Botts Dots, Right Departure, Visual Warning

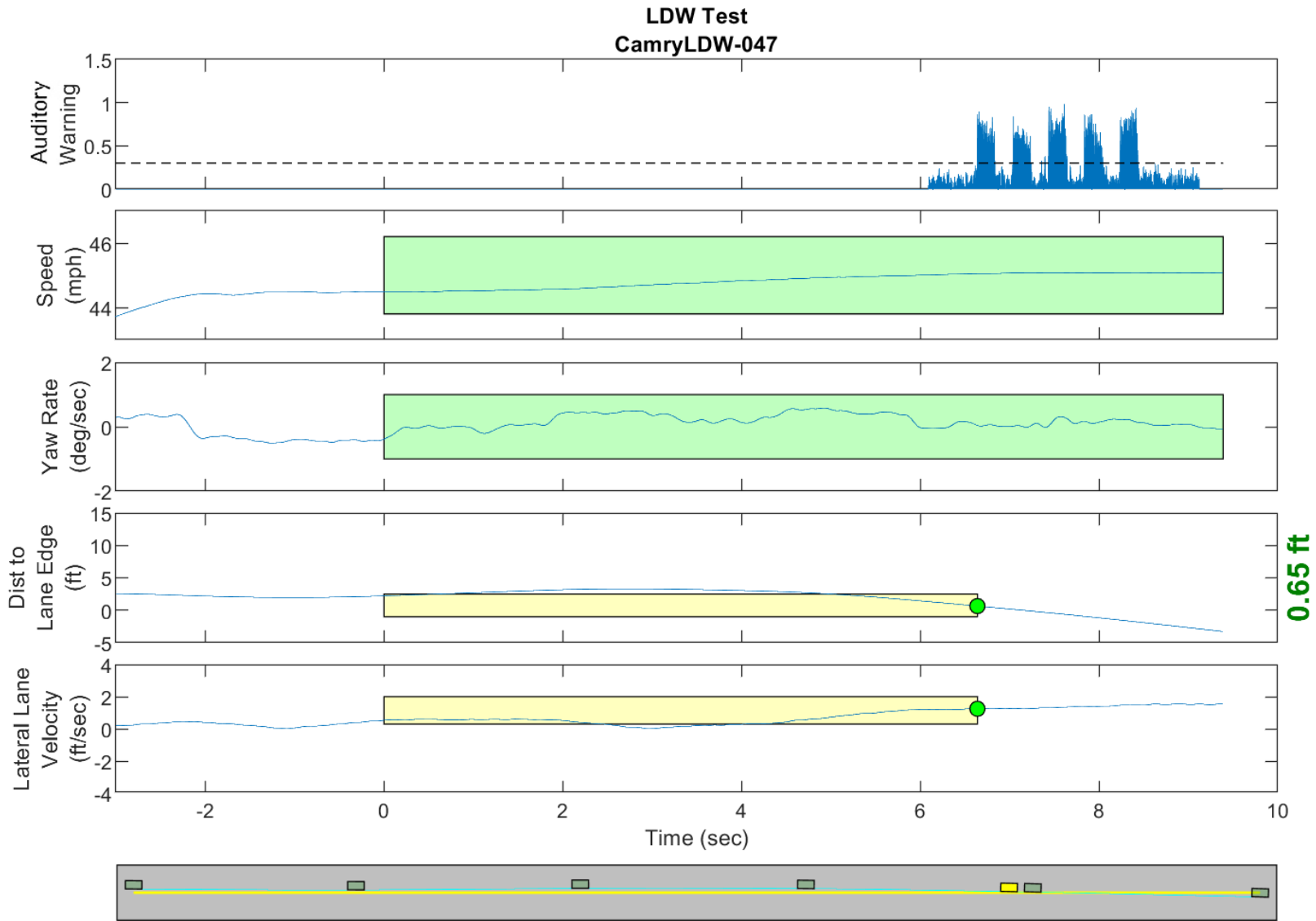

GPS Fix Type: RTK Fixed

Figure D76. Time History for Run 47, Botts Dots, Right Departure, Auditory Warning

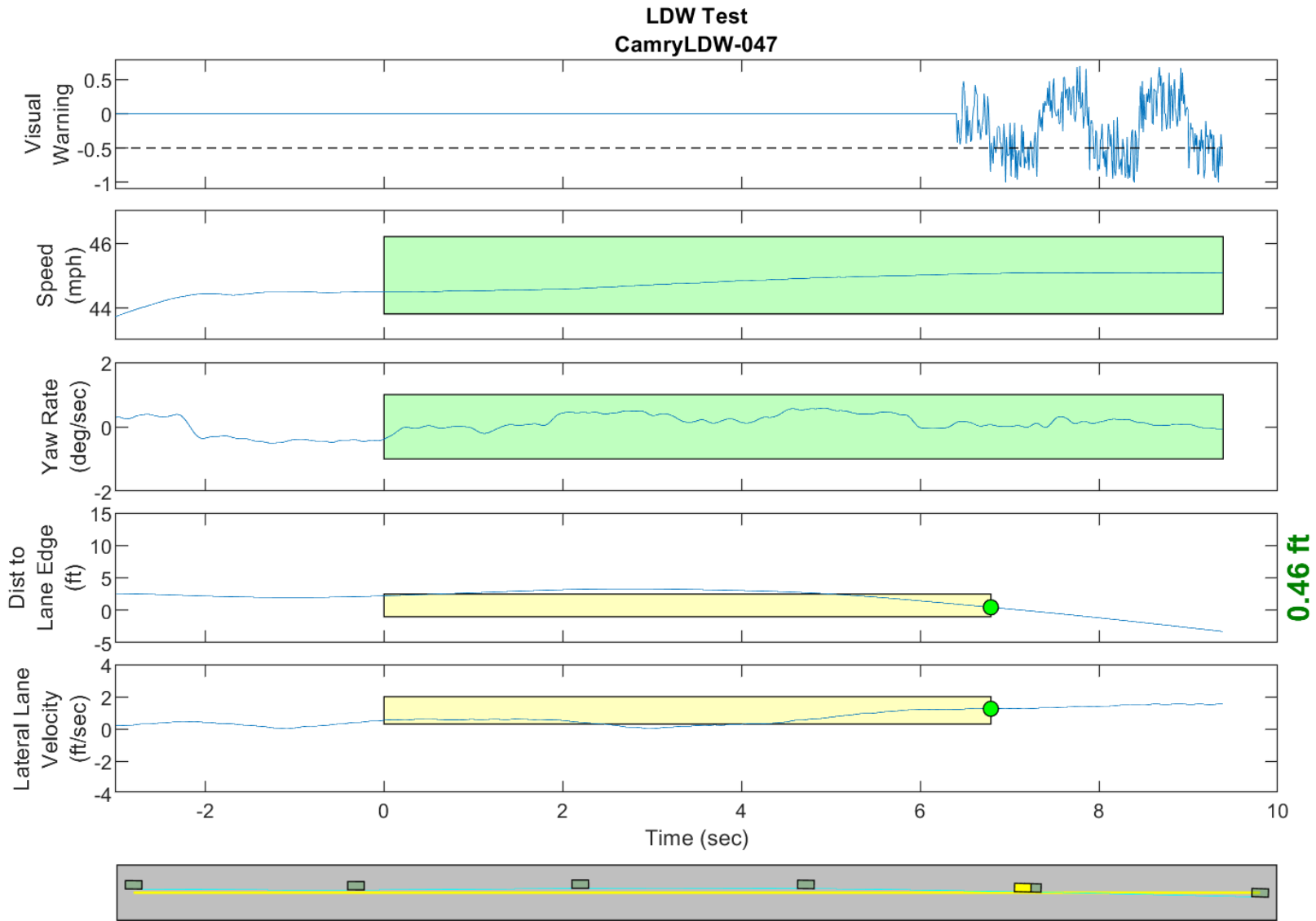

GPS Fix Type: RTK Fixed

Figure D77. Time History for Run 47, Botts Dots, Right Departure, Visual Warning

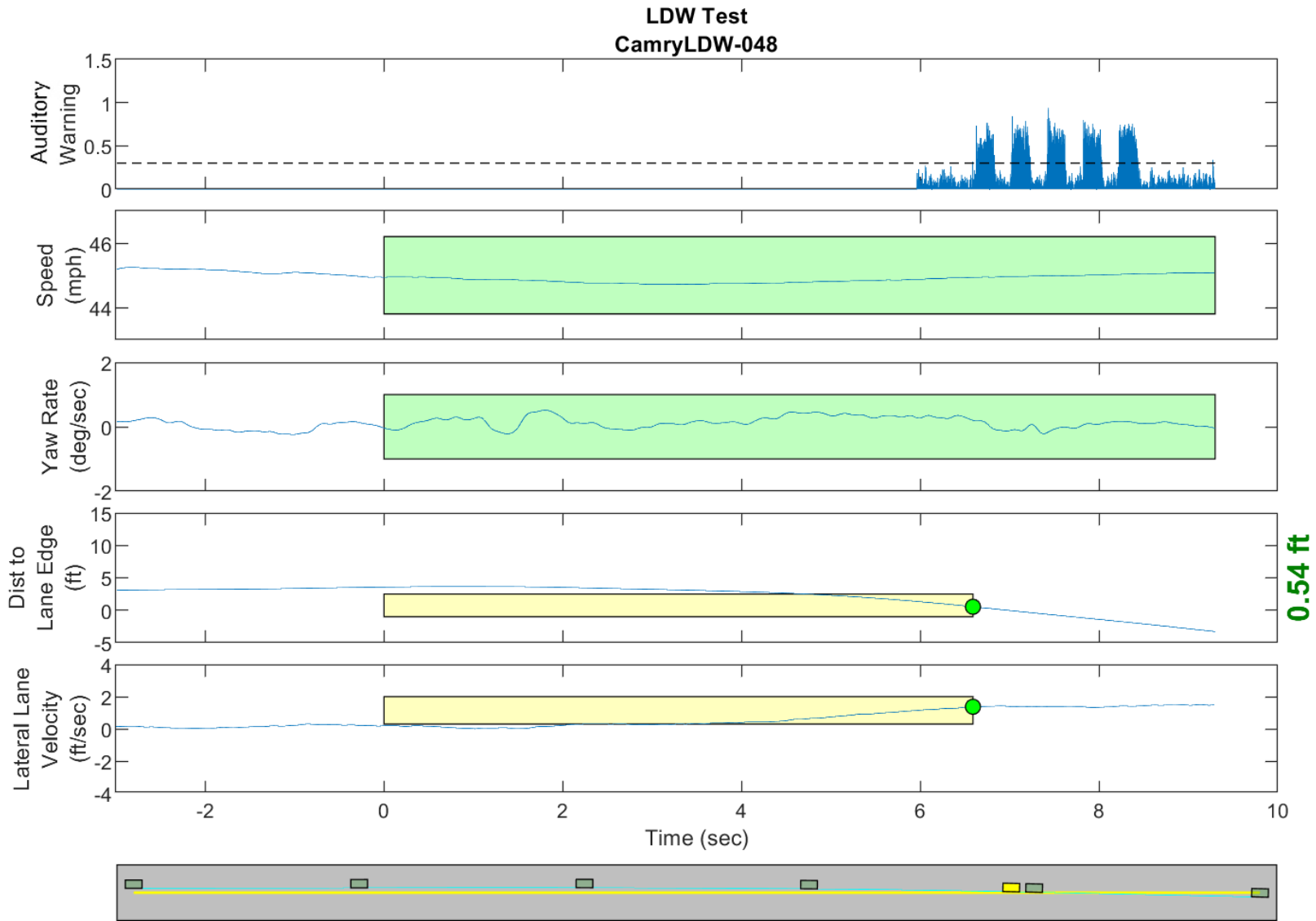

GPS Fix Type: RTK Fixed

Figure D78. Time History for Run 48, Botts Dots, Right Departure, Auditory Warning

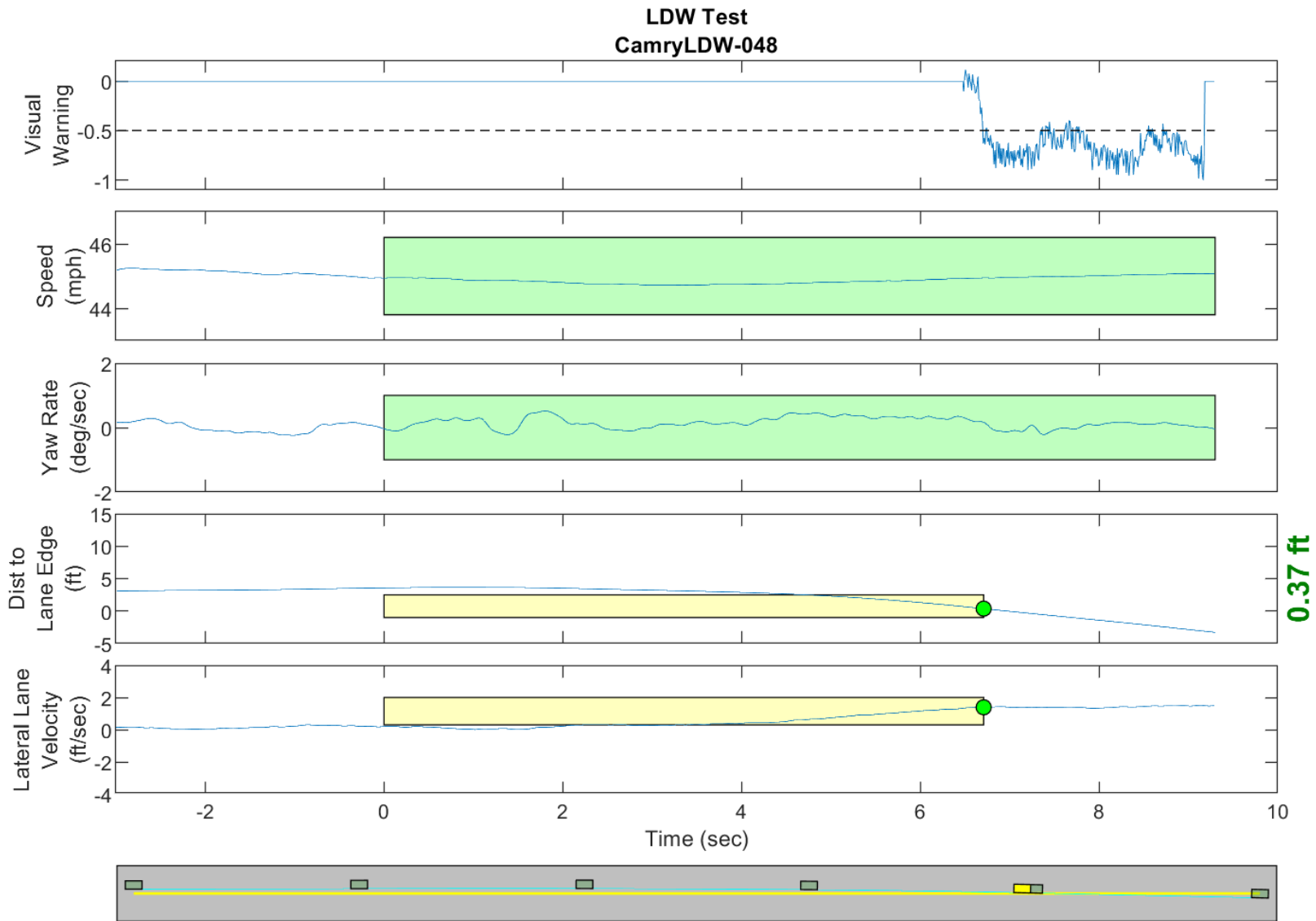

GPS Fix Type: RTK Fixed

Figure D79. Time History for Run 48, Botts Dots, Right Departure, Visual Warning

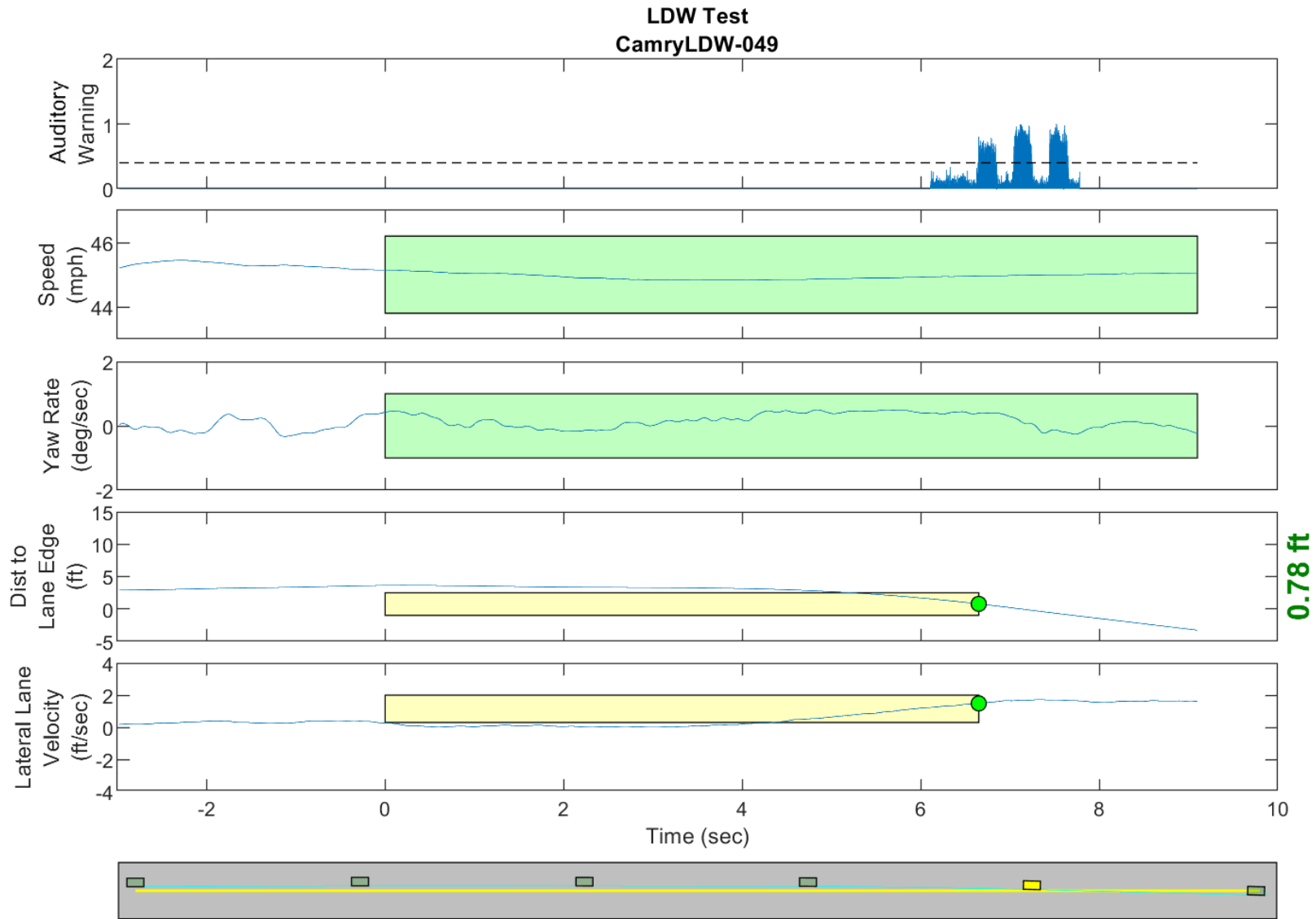

GPS Fix Type: RTK Fixed

Figure D80. Time History for Run 49, Botts Dots, Right Departure, Auditory Warning

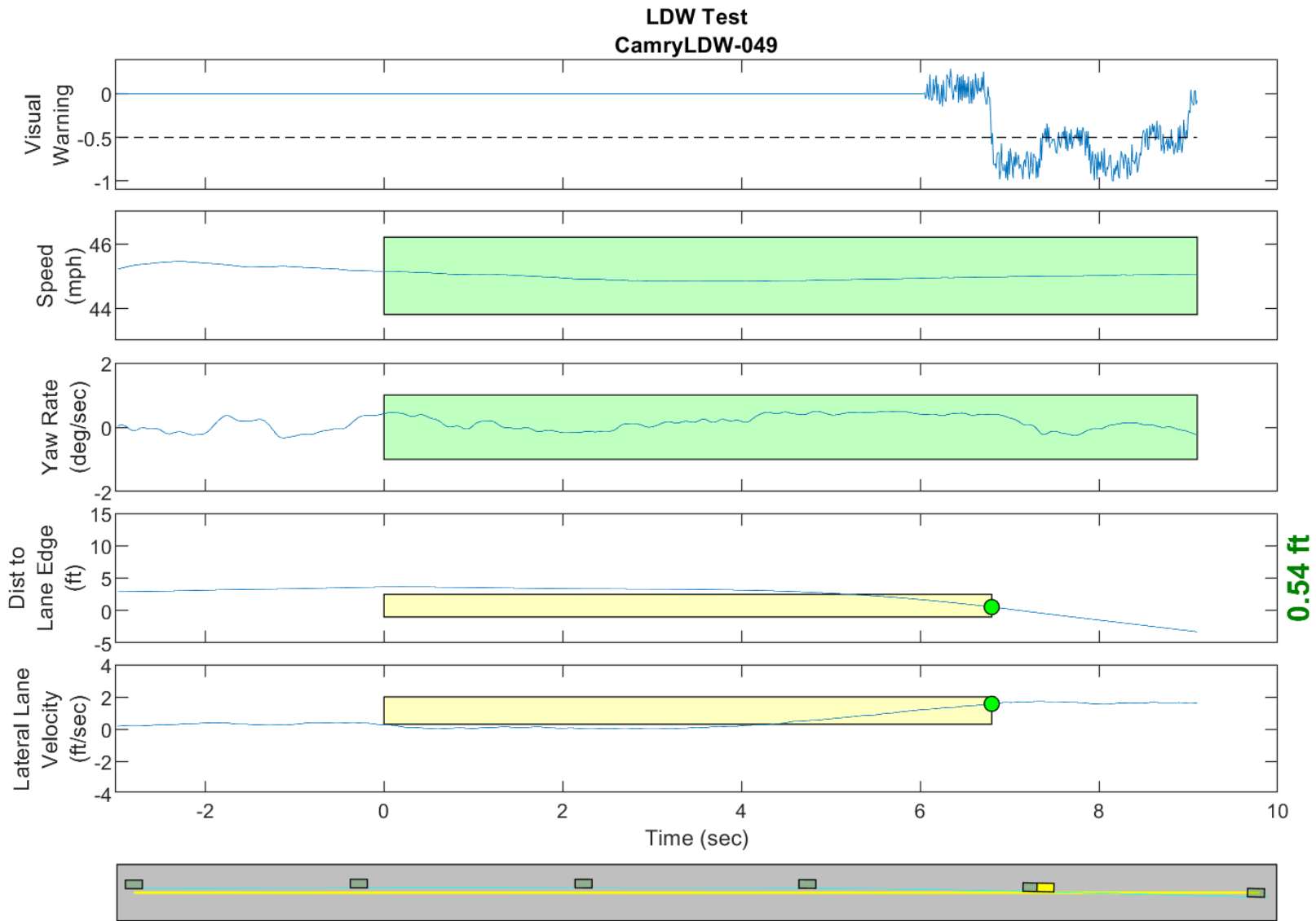

GPS Fix Type: RTK Fixed

Figure D81. Time History for Run 49, Botts Dots, Right Departure, Visual Warning

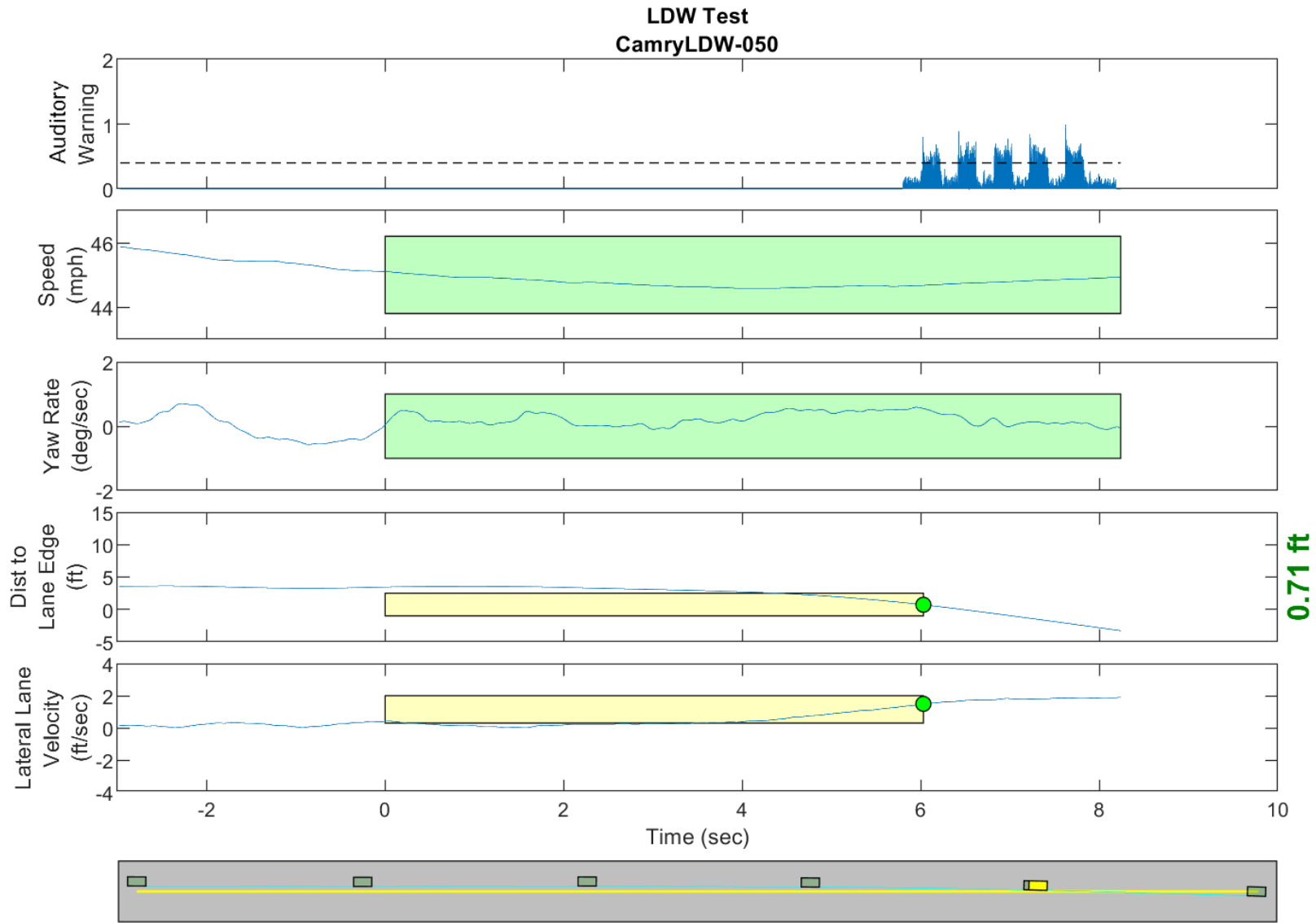

GPS Fix Type: RTK Fixed

Figure D82. Time History for Run 50, Botts Dots, Right Departure, Auditory Warning

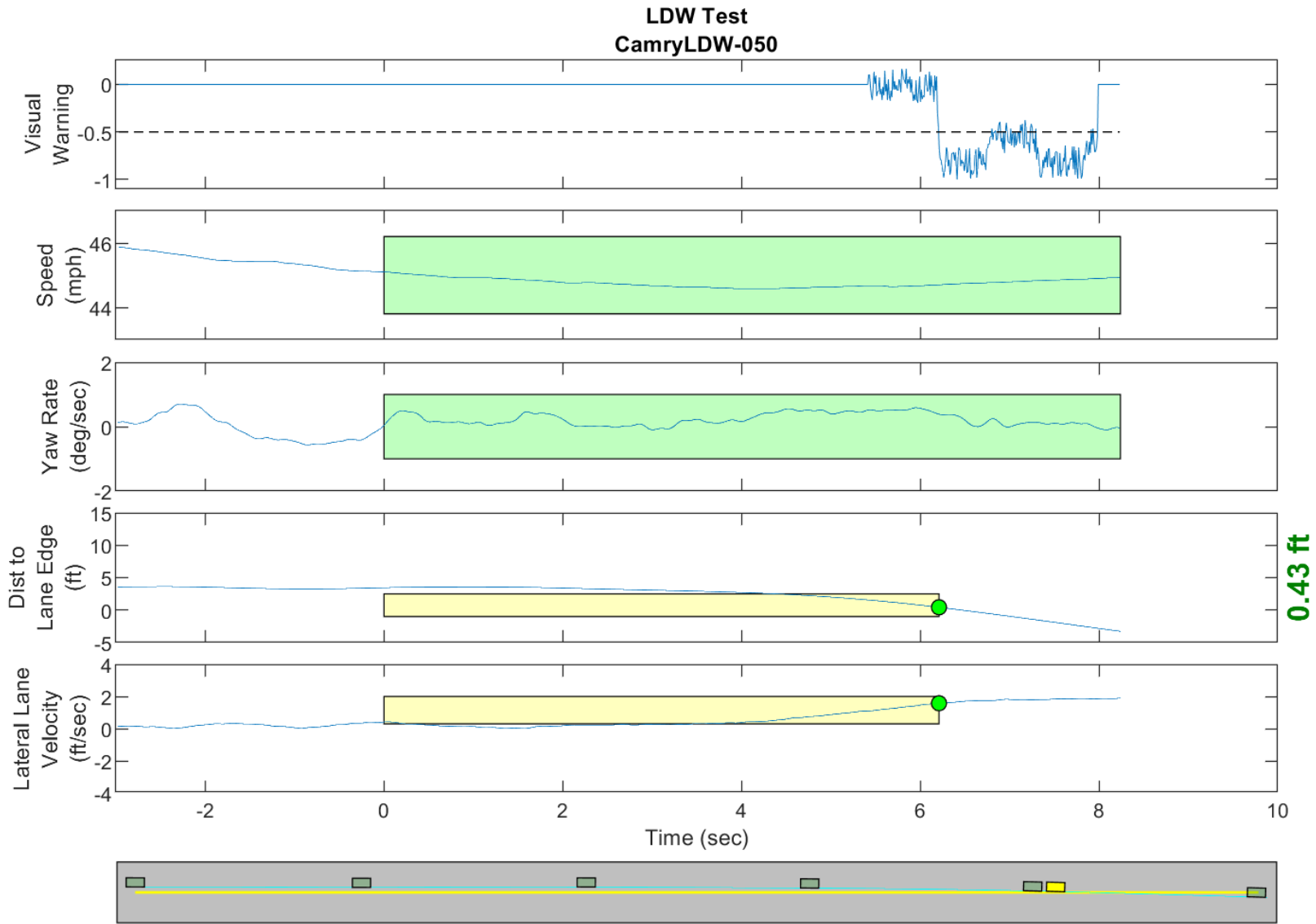

GPS Fix Type: RTK Fixed

Figure D83. Time History for Run 50, Botts Dots, Right Departure, Visual Warning

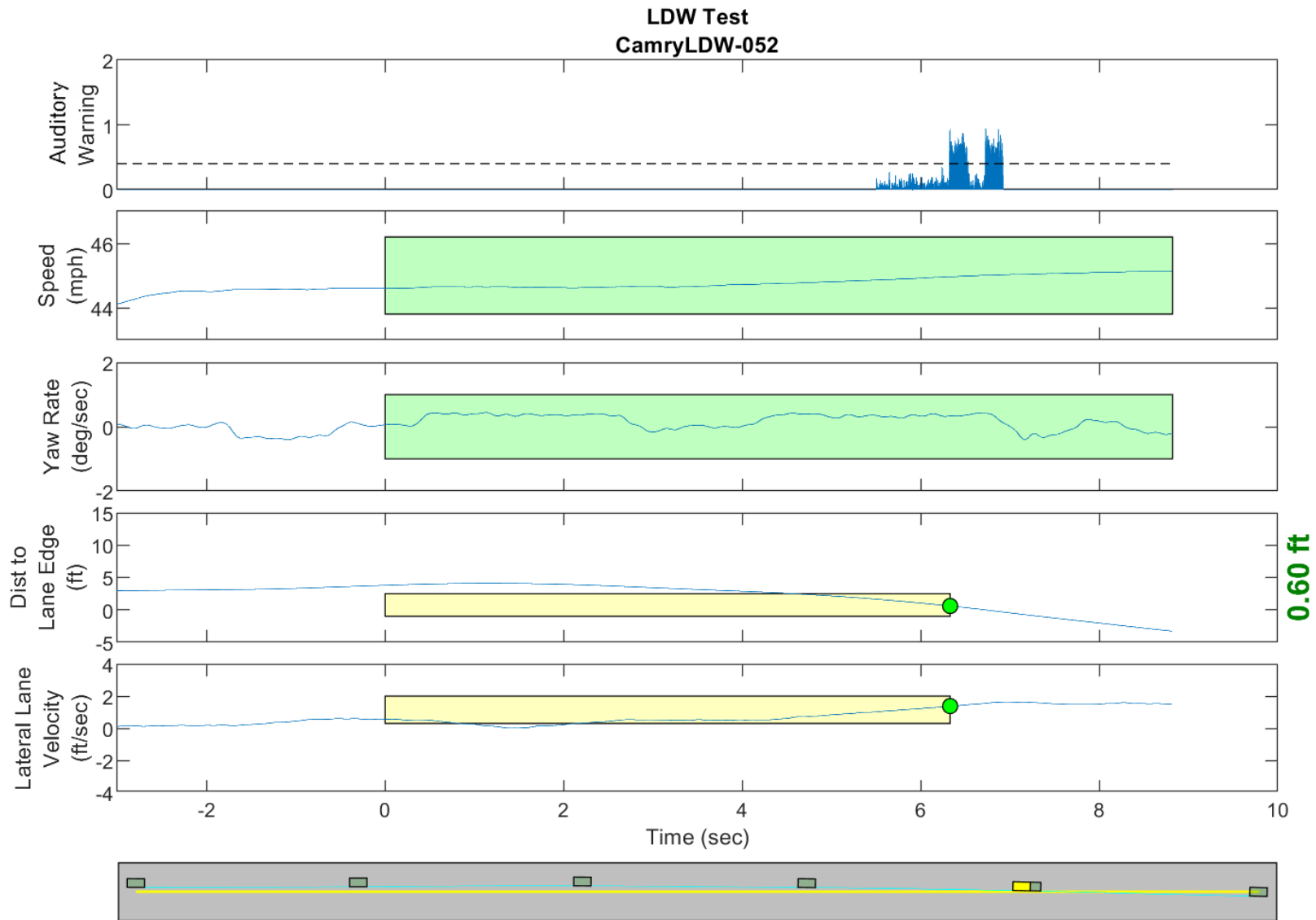

GPS Fix Type: RTK Fixed

Figure D84. Time History for Run 52, Botts Dots, Right Departure, Auditory Warning

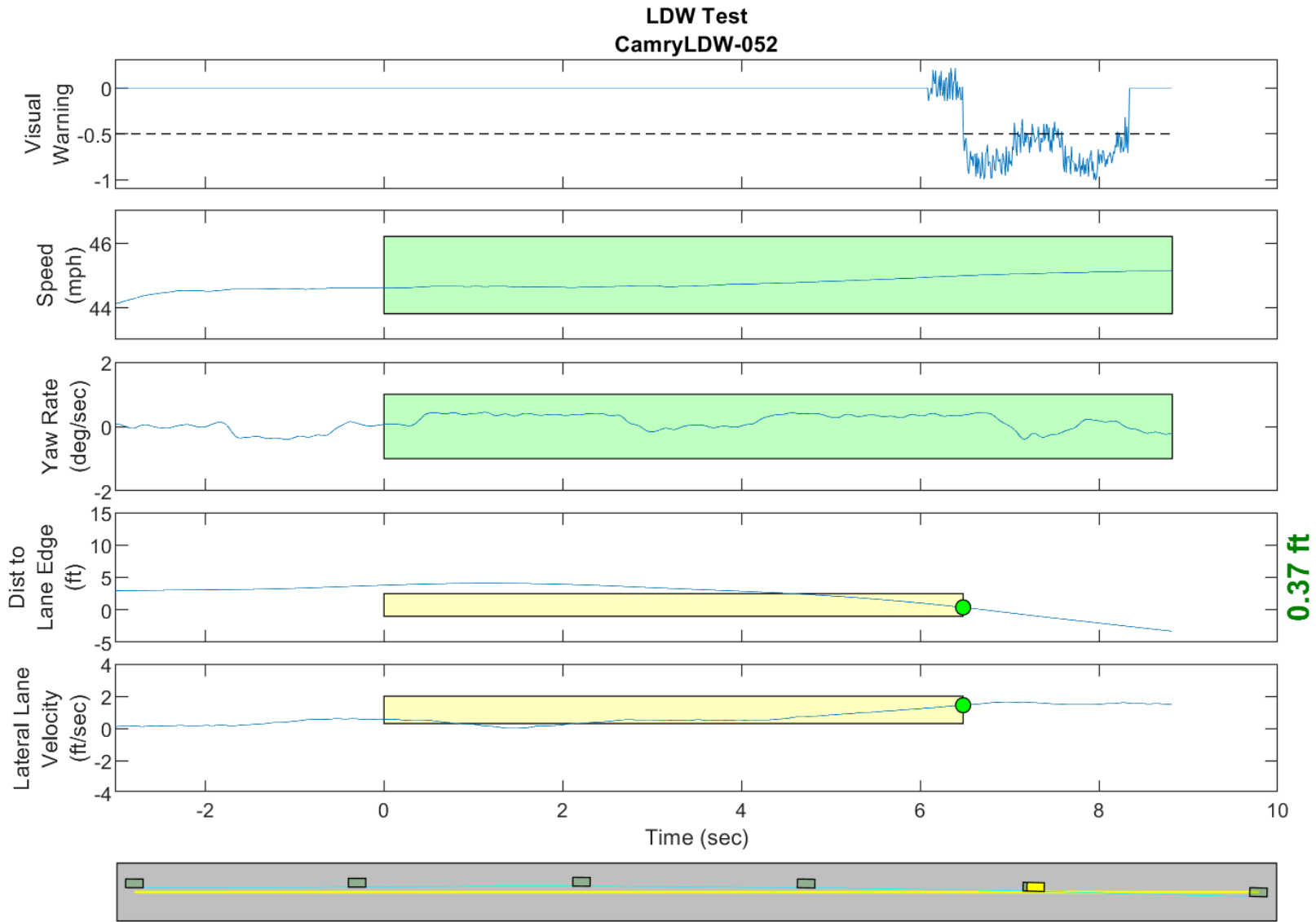

GPS Fix Type: RTK Fixed

Figure D85. Time History for Run 52, Botts Dots, Right Departure, Visual Warning

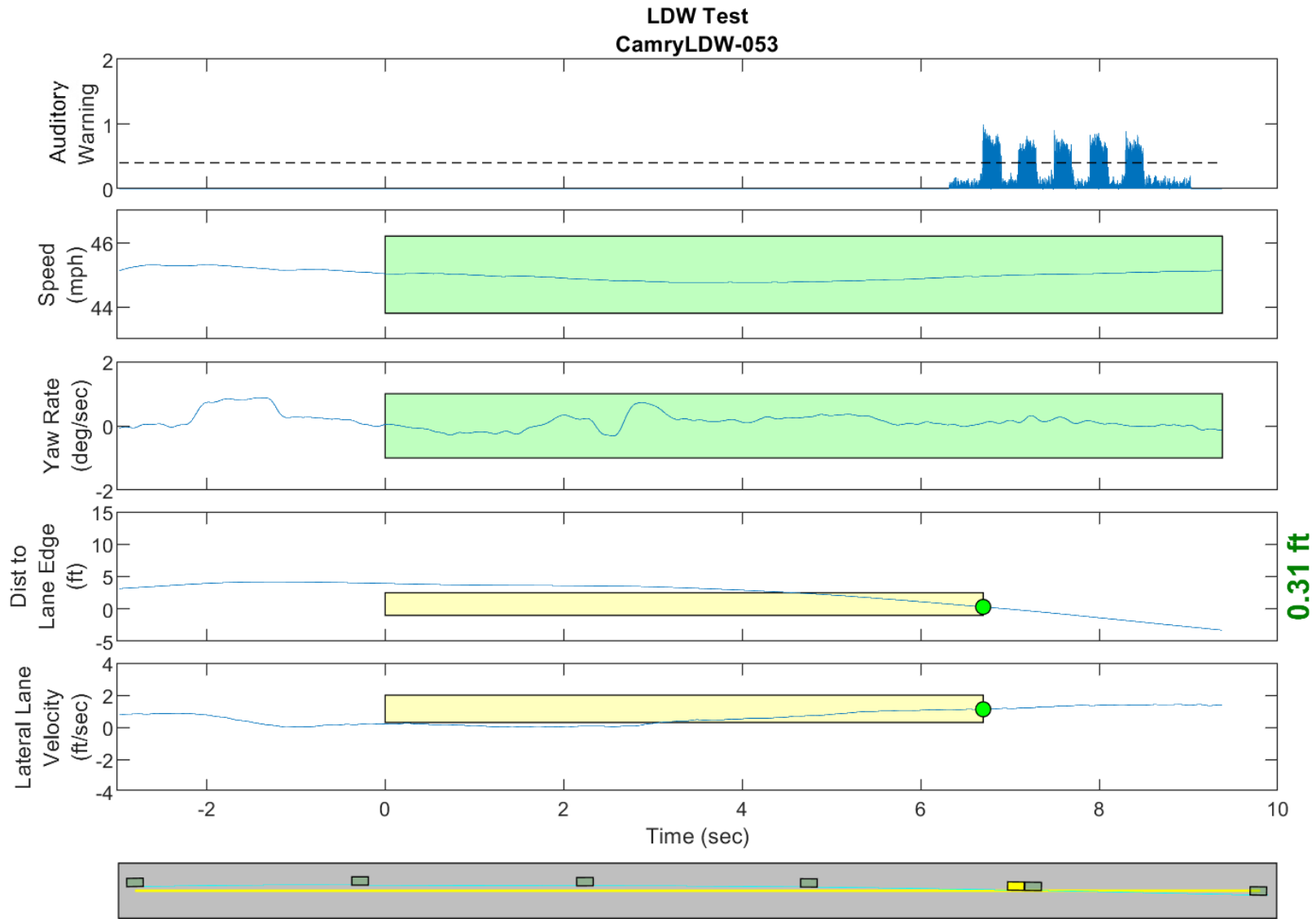

GPS Fix Type: RTK Fixed

Figure D86. Time History for Run 53, Botts Dots, Right Departure, Auditory Warning

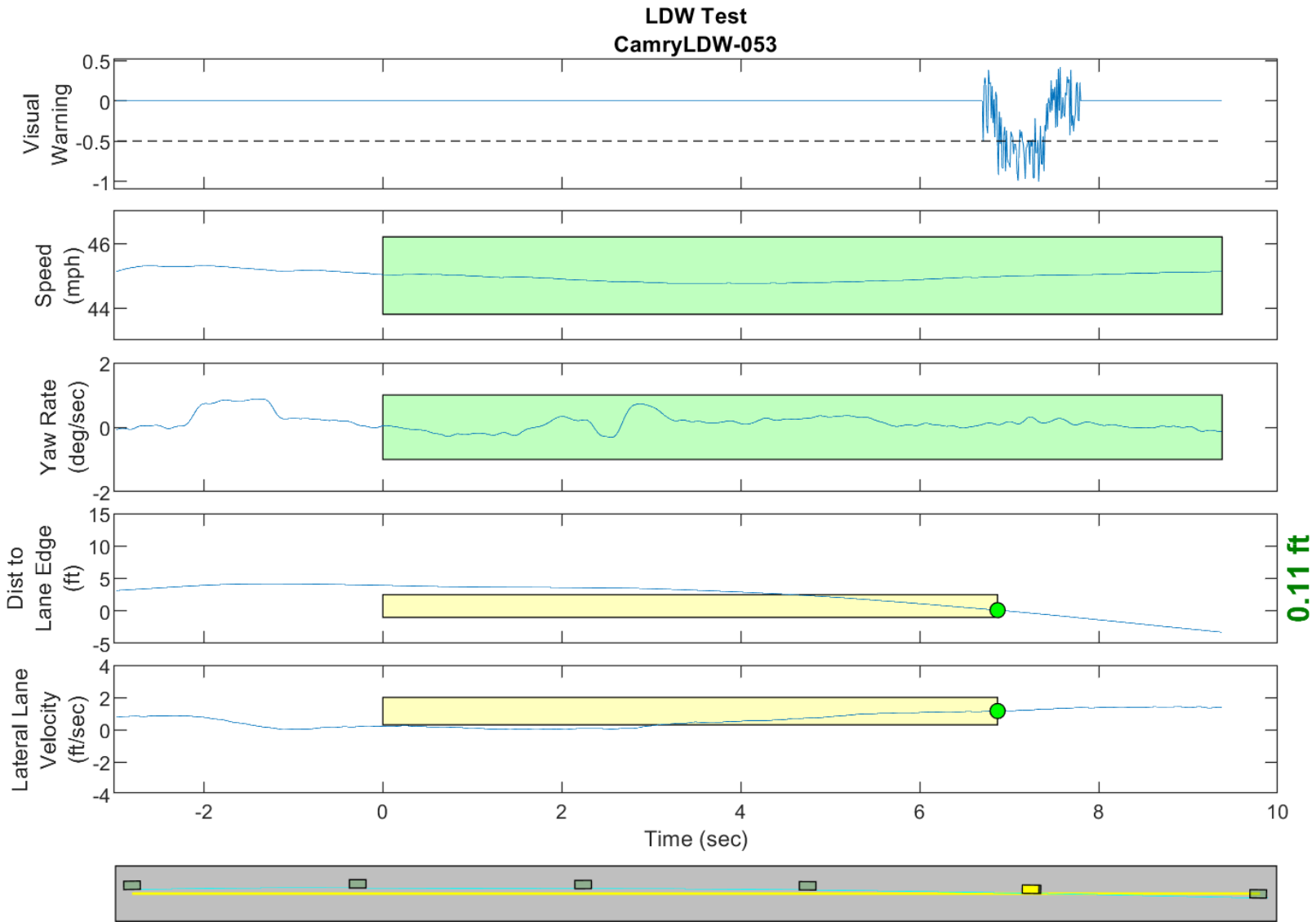

GPS Fix Type: RTK Fixed

Figure D87. Time History for Run 53, Botts Dots, Right Departure, Visual Warning