

REPORT NUMBER: SPNCAP-CAL-20-014

**NEW CAR ASSESSMENT PROGRAM (NCAP)
SIDE IMPACT POLE TEST**

**FCA US LLC
2020 Ram 1500 Classic
Crew Cab Truck**

NHTSA No: M20200311

**PREPARED BY:
CALSPAN CORPORATION
P.O. BOX 400
BUFFALO, NEW YORK 14225**



November 6, 2020

FINAL REPORT

**PREPARED FOR:
U.S. DEPARTMENT OF TRANSPORTATION
NATIONAL HIGHWAY TRAFFIC SAFETY ADMINISTRATION
OFFICE OF CRASHWORTHINESS STANDARDS
MAIL CODE: NRM-110
1200 NEW JERSEY AVE SE, ROOM W43-410
WASHINGTON, D.C. 20590**

This final test report was prepared for the U.S. Department of Transportation, National Highway Traffic Safety Administration, in response to Contract Number DTNH22-14-D-00352.

This publication is distributed by the U.S. Department of Transportation, National Highway Traffic Safety Administration, in the interest of information exchange. The opinions, findings and conclusions expressed in this publication are those of the author(s) and not necessarily those of the Department of Transportation or the National Highway Traffic Safety Administration. The United States Government assumes no liability for its contents or use thereof.

If trade or manufacturers' names or products are mentioned it is only because they are considered essential to the object of the publication and should not be construed as an endorsement. The United States Government does not endorse products or manufacturers.

Prepared by: Matthew Pronko
Matthew Pronko, Test Engineer

Date: November 6, 2020

Approved by: Vanessa Hansen
Vanessa Hansen, Operations Manager

Date: November 6, 2020

FINAL REPORT ACCEPTANCE BY OCWS:

Division Chief, New Car Assessment Program
NHTSA, Office of Crashworthiness Standards

Date: _____

COTR, New Car Assessment Program
NHTSA, Office of Crashworthiness Standards

Date: _____

TECHNICAL REPORT DOCUMENTATION PAGE

1. Report No. SPNCAP-CAL-20-014	2. Government Accession No.	3. Recipient's Catalog No.																												
4. Title and Subtitle Final Report of New Car Assessment Program Side Impact Pole Testing of a 2020 Ram 1500 Classic Crew Cab Truck NHTSA No.: M20200311		5. Report Date November 6, 2020																												
		6. Performing Organization Code CAL																												
7. Author(s) Matthew Pronko, Test Engineer Vanessa Hansen, Operations Manager		8. Performing Organization Report No. CAL-DOT-2020-014																												
9. Performing Organization Name and Address Calspan Corporation Transportation Test Operation P.O. Box 400 Buffalo, New York 14225		10. Work Unit No.																												
		11. Contract or Grant No. DTNH22-14-D-00352																												
12. Sponsoring Agency Name and Address U.S. Department of Transportation National Highway Traffic Safety Administration Office of Crashworthiness Standards (NRM-110) 1200 New Jersey Ave., SE, Room W43-410 Washington, D.C. 20590		13. Type of Report and Period Covered: Final Test Report, August 25, 2020 - November 6, 2020																												
		14. Sponsoring Agency Code NRM-110																												
15. Supplementary Notes																														
16. Abstract A 32.20 km/h (20 mph), 75° oblique impact Side NCAP Test was conducted on the subject 2020 Ram 1500 Classic Crew Cab Truck in accordance with the specifications of the Office of Crashworthiness Standards Side NCAP Pole Laboratory Test Procedure for the generation of consumer information on vehicle side pole crash protection. This test was conducted at Calspan Corporation's Transportation Test Operations facility in Buffalo, New York on August 25, 2020. The impact velocity of the vehicle was 32.00 km/h, and the ambient temperature at the struck (driver's) side of the target vehicle was 21°C. The target vehicle's maximum post-test static crush was 441 mm located at level 2. The test vehicle's occupant performance data is as follows:																														
<table border="1"> <thead> <tr> <th rowspan="2">Measurement Description</th> <th colspan="3">Driver ATD (SID-IIs) (Serial No. DG8012)</th> </tr> <tr> <th>Units</th> <th>Threshold</th> <th>Result</th> </tr> </thead> <tbody> <tr> <td>Head Injury Criteria (HIC₃₆)</td> <td></td> <td>1000</td> <td>257.760</td> </tr> <tr> <td>Resultant Lower Spine Acceleration</td> <td>G</td> <td>82</td> <td>47.255</td> </tr> <tr> <td>Total Pelvic Force (sum of acetabular and iliac forces)</td> <td>N</td> <td>5525</td> <td>3598.422</td> </tr> <tr> <td>Maximum Thoracic Rib Deflection</td> <td>mm</td> <td>38</td> <td>18.620</td> </tr> <tr> <td>Maximum Abdomen Rib Deflection</td> <td>mm</td> <td>45</td> <td>27.972</td> </tr> </tbody> </table>				Measurement Description	Driver ATD (SID-IIs) (Serial No. DG8012)			Units	Threshold	Result	Head Injury Criteria (HIC ₃₆)		1000	257.760	Resultant Lower Spine Acceleration	G	82	47.255	Total Pelvic Force (sum of acetabular and iliac forces)	N	5525	3598.422	Maximum Thoracic Rib Deflection	mm	38	18.620	Maximum Abdomen Rib Deflection	mm	45	27.972
Measurement Description	Driver ATD (SID-IIs) (Serial No. DG8012)																													
	Units	Threshold	Result																											
Head Injury Criteria (HIC ₃₆)		1000	257.760																											
Resultant Lower Spine Acceleration	G	82	47.255																											
Total Pelvic Force (sum of acetabular and iliac forces)	N	5525	3598.422																											
Maximum Thoracic Rib Deflection	mm	38	18.620																											
Maximum Abdomen Rib Deflection	mm	45	27.972																											
The two doors on the struck side of the vehicle did not separate from the body at the hinges or latches and the opposite doors did not open during the side impact event.																														
17. Key Words New Car Assessment Program (NCAP) Side Impact Pole Part 572V SID-IIs		18. Distribution Statement Copies of this report are available from: National Highway Traffic Safety Administration Technical Information Services Division, 1200 New Jersey Ave. SE Washington, D.C. 20590																												
19. Security Class. (of this report) UNCLASSIFIED	20. Security Class. (of this page) UNCLASSIFIED	21. No. of Pages 123	22. Price																											

TABLE OF CONTENTS

<u>Section</u>		<u>Page</u>
1	Test Purpose and Procedure	1-1
2	Summary of Test Results	2-1
3	Occupant and Vehicle Information	3-1
 <u>Data Sheet</u>		 <u>Page</u>
1	General Test and Vehicle Parameter Data	3-2
2	Seat, Seat Belt, Steering Wheel Adjustment and Fuel Systems Data	3-6
3	Dummy Longitudinal Clearance Dimensions	3-9
4	Dummy Lateral Clearance Dimensions	3-10
5	Camera and instrumentation Data	3-11
6	Vehicle Accelerometer Data	3-12
7	Rigid Pole Load Cell Data	3-13
8	Post-Test Observations	3-14
9	Test Vehicle Profile Measurements	3-16
10	Test Vehicle Exterior Crush Measurements	3-17
11	Vehicle Damage Profile Distances	3-20
12	FMVSS No. 301 Static Rollover Results	3-21
13	Dummy / Vehicle Temperature and Humidity Stabilization Data	3-22
 <u>Appendix</u>		 <u>Page</u>
A	Photographs	A-1
B	Vehicle and Dummy Response Data Plots	B-1
C	Dummy Configuration and Performance Verification Data	C-1
D	Test Equipment and Instrumentation Calibration Data	D-1

SECTION 1

TEST PURPOSE AND PROCEDURE

This side impact test was conducted as part of the MY 2020 New Car Assessment Program Side Impact Test Program, sponsored by the National Highway Traffic Safety Administration (NHTSA), under Contract No. DTNH22-14-D-00352. The purpose of this test is to generate comparative side impact performance in a 2020 Ram 1500 Classic Crew Cab Truck. The side impact test was conducted in accordance with the Office of Crashworthiness Standard's Side NCAP Pole Laboratory Test Procedure, dated October 2015.

SECTION 2

SUMMARY OF TEST RESULTS

A rigid pole side impact test was conducted on a 2020 Ram 1500 Classic Crew Cab Truck. The subject vehicle was towed into the rigid pole at an angle of 75° and a velocity of 32.00 km/h. The test was conducted by Calspan Corporation's Transportation Test Operations facility in Buffalo, New York on August 25, 2020. Pre-test and post-test photographs of the test vehicle and side impact dummy (SID-IIs) are included in Appendix A of this report.

One Part 572V (SID-IIs) dummy was placed in the driver designated seating position according to instructions specified in the OCWS Side NCAP Pole Laboratory Test Procedure, dated October 2015. Camera locations and other pertinent camera information are included on page 3-11 in this report.

The Part 572V (SID-IIs) dummy was instrumented accordingly:

Head CG tri-axial accelerometers

Thorax upper, middle, and lower rib displacement potentiometers

Abdomen upper and lower rib displacement potentiometers

Lower spine tri-axial accelerometers

Iliac load cell

Acetabulum load cell

Appendix B contains the dummy response data. Dummy configuration and performance verification data can be found in Appendix C of this report. Appendix D identifies all serial numbers, manufacturers, and calibration dates for test equipment, dummy sensors, potentiometers, and load cells used to collect data during the test.

Injury readings for the SID-IIs dummy were recorded as follows:

INJURY READINGS

Measurement Description	Driver ATD (SID-IIs)		
	Units	IARV	Result
Head Injury Criteria (HIC ₃₆)		1000	257.760
Resultant Lower Spine Acceleration	g	82	47.255
Total Pelvic Force (sum of acetabular and iliac forces)	N	5525	3598.422
Maximum Thoracic Rib Deflection	mm	38*	18.620
Maximum Abdominal Rib Deflection	mm	45*	27.972

*Proposed IARV

Supplemental restraint information was recorded as follows:

SUPPLEMENTAL RESTRAINT INFORMATION

Restraint Type	Left Front (Driver) Occupant Location 1		Left Rear (Passenger) Occupant Location 4	
	Mounted	Deployed	Mounted	Deployed
Frontal Airbag	Yes	No		
Knee Airbag	Yes	No		
Side Airbag 1 - Curtain	Yes	Yes	Yes	Yes
Side Airbag 2 – Torso/Pelvis	Yes	Yes	No	N/A
Seat Belt Pretensioner	Yes	Yes	No	N/A
Seat Belt Load Limiter	Yes	Yes	No	N/A
Other				

GENERAL COMMENTS:

1. P1 serial number – DG8012

Data Anomalies:

- Left Front Sill Y Acceleration, Exceeded calibration range and saturated at 25.2 ms
- Left Mid B-Pillar Y Acceleration, Exceeded Calibration Range at 12.6 ms

SECTION 3
OCCUPANT AND VEHICLE INFORMATION

This section contains information reporting for the following Data Sheets:

Data Sheet No. 1 – General Test and Vehicle Parameter Data

Data Sheet No. 2 – Seat, Seat Belt, Steering Wheel Adjustment and Fuel Systems Data

Data Sheet No. 3 – Dummy Longitudinal Clearance Dimensions

Data Sheet No. 4 – Dummy Lateral Clearance Dimensions

Data Sheet No. 5 – Camera and instrumentation Data

Data Sheet No. 6 – Vehicle Accelerometer Data

Data Sheet No. 7 – Rigid Pole Load Cell Data

Data Sheet No. 8 – Post-Test Observations

Data Sheet No. 9 – Test Vehicle Profile Measurements

Data Sheet No. 10 – Test Vehicle Exterior Crush Measurements

Data Sheet No. 11 – Vehicle Damage Profile Distances

Data Sheet No. 12 – FMVSS No. 301 Static Rollover Results

Data Sheet No. 13 – Dummy / Vehicle Temperature and Humidity Stabilization Data

**DATA SHEET NO. 1
GENERAL TEST AND VEHICLE PARAMETER DATA**

Test Vehicle: 2020 Ram 1500 Classic Crew Cab Truck
 Test Program: NCAP Side Pole Impact Test

NHTSA No.: M20200311
 Test Date: 8/25/2020

TEST VEHICLE INFORMATION AND OPTIONS

NHTSA No.	M20200311
Model Year	2020
Make	Ram
Model	1500 Classic
Body Style	Crew Cab Truck
VIN	1C6RR6LT2LS127774
Body Color	Silver
Odometer Reading (km/mi)	25 mi
Engine Displacement (L)	5.7
Type / No. Cylinders	V8
Engine Placement	Inline
Transmission Type	Automatic
Transmission Speeds	8-Speed
Overdrive	Yes
Final Drive	Rear Wheel Drive
Roof Rack	No
Sunroof / T-Top	No
Running Boards	No
Tilt Steering Wheel	Yes
Power Seats	No
Anti-Lock Brakes (ABS)	Yes

Traction Control System (TCS)	Yes
Auto-Leveling System	No
Automatic Door Locks (ADL)	Yes
Power Window Auto-Reverse	No
Other Optional Feature	-
Driver Front Airbag	Yes
Driver Curtain Airbag	Yes
Driver Head/Torso Airbag	No
Driver Torso Airbag	No
Driver Torso / Pelvis Airbag	Yes
Driver Pelvis Airbag	No
Driver Knee Airbag	No
Rear Pass. Curtain Airbag	Yes
Rear Pass. Head / Torso Airbag	No
Rear Pass. Torso Airbag	No
Rear Pass. Torso / Pelvis Airbag	No
Rear Pass. Pelvis Airbag	No
Driver Seat Belt Pretensioner	Yes
Rear Pass. Seat Belt Pretensioner	No
Driver Load Limiter	Yes
Rear Pass. Load Limiter	No
Other Safety Restraint	-

Does owner's manual provide instructions to turn off automatic door locks?

Yes

DATA FROM CERTIFICATION LABEL

Manufactured By	FCA US LLC
Date of Manufacture	2-20
Vehicle Type	Truck

GVWR (kg)	3130
GAWR Front (kg)	1679
GAWR Rear (kg)	1770

VEHICLE SEATING AND WEIGHT CAPACITY DATA

Measured Parameter	Front	Rear	Third	Total		
Designated Seating Capacity (DSC)	3	3	-	6		
Capacity Weight (VCW) (kg)					717	(A)
DSC X 68.04 kg					408.24	(B)
Cargo Weight (RCLW) (kg)					136	(A-B)

VEHICLE SEAT TYPE

Seating Location	Type of Seat Pan				Type of Seat Back		
	Bucket	Bench	Split Bench	Contoured	Fixed	Adjustable	
						W/ Lever	W/ Knob
Front Seat	X					X	
Rear or Second Row Seat			X		X		
Third Row seat							

DATA SHEET NO. 1 ... (CONTINUED)
GENERAL TEST AND VEHICLE PARAMETER DATA

Test Vehicle: 2020 Ram 1500 Classic Crew Cab Truck
 Test Program: NCAP Side Pole Impact Test

NHTSA No.: M20200311
 Test Date: 8/25/2020

Collected for year, make, model, & VIN, all items circled in red, tire manufacturer and tire name.

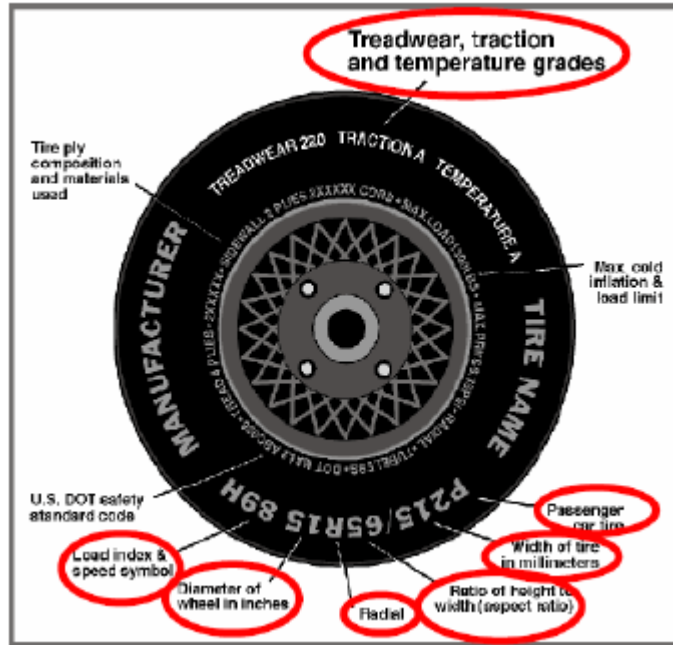

VEHICLE TIRE INFORMATION

Measured Parameter	Front	Rear
Maximum Tire Pressure (kPa)	300	300
Cold Pressure (kPa)	270	270
Recommended Tire Size	P275/60R20	P275/60R20
Tire Size on Vehicle	P275/60R20	P275/60R20
Tire Manufacturer	Goodyear	Goodyear
Tire Model	Wrangler SRA	Wrangler SRA
Treadwear	500	500
Traction	A	A
Temperature Grades	B	B
Tire Plies Sidewall	2 Polyester	2 Polyester
Tire Plies Body	2 Polyester, 2 Steel	2 Polyester, 2 Steel
Load Index/Speed Symbol	114S	114S
Tire Material	Rubber	Rubber
DOT Safety Code Left	M6YNJD1R0420	M6YNJD1R0420
DOT Safety Code Right	M6YNJD1R0420	M6YNJD1R0420

DATA SHEET NO. 1 ... (CONTINUED)
GENERAL TEST AND VEHICLE PARAMETER DATA

Test Vehicle: 2020 Ram 1500 Classic Crew Cab Truck
 Test Program: NCAP Side Pole Impact Test

NHTSA No.: M20200311
 Test Date: 8/25/2020

TIRE PRESSURES

	Units	LF	RF	LR	RR
As Delivered	kPa	267	265	266	267
Tire Placard	kPa	270	270	270	270
Owner's Manual	kPa	270	270	270	270
As Tested	kPa	270	270	270	270

TEST VEHICLE AXLE WEIGHTS

	Units	As Delivered (UVW)			As Tested (ATW)			Fully Loaded		
		Front	Rear	Total	Front	Rear	Total	Front	Rear	Total
Left	kg	690	538		710	609		714	626	
Right	kg	694	501		716	567		695	580	
Ratio	%	57.1	42.9		54.8	45.2		53.9	46.1	
Totals	kg	1384	1039	2423	1426	1176	2602	1409	1206	2615

TARGET TEST WEIGHT CALCULATION

Measured Parameter	Units	Value	
Total As Delivered Weight (UVW)	kg	2423	(A)
Actual Weight of 1 P572V (SID-IIs) ATD Used	kg	50	(B)
Rated Cargo / Luggage Weight (RCLW)	kg	136	(C)
Calculated Vehicle Target Weight (TVTW)	kg	2609	(A+B+C)

Does the measured As Test Vehicle Weight lie within the required weight range
 (i.e. Calculated Test Vehicle Target Weight – 4.5 kg to – 9 kg)? Yes No

TEST VEHICLE ATTITUDES AND CG

Measurement Description	Units	As Delivered	As Tested	Fully Loaded	Meets Rqmt***
Driver Door Sill Angle (front-to-rear)*	Deg	-1.05	-0.80	-0.70	Yes
Front Passenger Sill Angle (front-to-rear)*	Deg	-1.50	-1.30	-1.30	Yes
Front Bumper-Line Angle (left-to-right)**	Deg	-0.25	-0.30	-0.35	Yes
Rear Bumper-Line Angle (left-to-right)**	Deg	+0.10	0.0	0.0	Yes
Vehicle CG (Aft of Front Axle)	mm	1530	1613	1646	
Vehicle CG (Left (+) / Right (-) from Longitudinal Centerline)	mm	12	12	22	

* ND = Nose Down (-), NU = Nose Up (+)

** LD = Left Down (-), LU = Left Up (+)

*** The "As Tested" vehicle attitude measurements must be equal to or between the "As Delivered" and "Fully Loaded" vehicle attitude measurements. Indicate "Yes" or "No" for Meets Requirement"

DATA SHEET NO. 1 ... (CONTINUED)
GENERAL TEST AND VEHICLE PARAMETER DATA

Test Vehicle: 2020 Ram 1500 Classic Crew Cab Truck
 Test Program: NCAP Side Pole Impact Test

NHTSA No.: M20200311
 Test Date: 8/25/2020

WEIGHT OF BALLAST AND VEHICLE COMPONENTS REMOVED TO MEET TVTW

Component Description	Weight (kg)
Nothing was removed	0
Ballast / Equipment Added	91.5

Test Height – Adjustable Suspension Setting, if Applicable	N/A
--	-----

DATA SHEET NO. 2
SEAT, SEAT BELT, STEERING WHEEL ADJUSTMENT AND FUEL SYSTEMS DATA

Test Vehicle: 2020 Ram 1500 Classic Crew Cab Truck
 Test Program: NCAP Side Pole Impact Test

NHTSA No.: M20200311
 Test Date: 8/25/2020

SEAT POSITIONING

The driver's seat, front center seat (if applicable), and right front passenger's seat should be set to the forward-most, mid-height, mid-angle position. The struck-side rear passenger's seat, rear center seat, and non-struck side rear passenger's seats should be set to the rear-most, lowest, mid-angle position.

SCRL ANGLE RANGE

Seat	SCRL (°)		
	Max	Min	Mid
Driver Seat	Not Adjustable		
Front Passenger Seat	Not Adjustable		
Front Center Seat	Not Adjustable		
Struck Side Rear Seat	Fixed	Fixed	Fixed
Non-Struck Side Rear Seat	Fixed	Fixed	Fixed
Rear Center Seat	Fixed	Fixed	Fixed

SEAT HEIGHT AND ANGLE

Seat	As Tested SCRL Angle (Mid) (°)	As Tested SCRP Height (mm)	SCRP Height Position	SCRP Height (mm)		
				Rearmost	Mid-Fore / Aft	Forward-Most
Driver Seat	Not Adjustable		Max	-	-	-
			Mid	-	-	-
			Min	-	-	-
Front Passenger Seat	Not Adjustable		Max	-	-	-
			Mid	-	-	-
			Min	-	-	-
Front Center Seat	Not Adjustable		Max	-	-	-
			Mid	-	-	-
			Min	-	-	-
Struck Side Rear Seat	Fixed	Fixed	Max	-	-	-
			Mid	-	-	-
			Min	-	-	-
Non-Struck Side Rear Seat	Fixed	Fixed	Max	-	-	-
			Mid	-	-	-
			Min	-	-	-
Rear Center Seat	Fixed	Fixed	Max	-	-	-
			Mid	-	-	-
			Min	-	-	-

DATA SHEET NO. 2 ... (CONTINUED)
SEAT, SEAT BELT, STEERING WHEEL ADJUSTMENT AND FUEL SYSTEMS DATA

Test Vehicle: 2020 Ram 1500 Classic Crew Cab Truck
 Test Program: NCAP Side Pole Impact Test

NHTSA No.: M20200311
 Test Date: 8/25/2020

SEAT FORE / AFT POSITION

Seat	Total Fore / Aft Travel		Test Position from Forward most Position	
	mm	Detents*	mm	Detents*
Driver Seat	230	24 (0-23)	0	0
Front Passenger Seat	230	24 (0-23)	0	0
Front Center Seat	N/A	N/A	N/A	N/A
Struck Side Rear Seat	FIXED	FIXED	FIXED	FIXED
Non-Struck Side Rear Seat	FIXED	FIXED	FIXED	FIXED
Rear Center Seat	FIXED	FIXED	FIXED	FIXED

SEAT BACK ANGLE ADJUSTMENT

The driver's seat back is positioned such that the dummy's head is level. The front center and front passenger's seat backs are positioned in a similar manner as the driver's seat back. The struck-side rear passenger seat back is positioned in accordance with the information provided by the manufacturer on Form No. 1 for the 5th percentile female dummy in a Side NCAP MDB test. The rear center and non-struck side rear passenger's seat back are set to match the struck-side rear seat back.

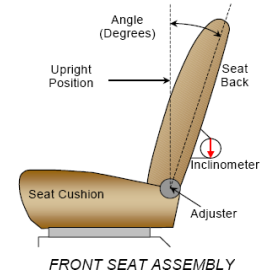

Seat	Total Seat Back Angle Range		Test Position from Most Upright	
	Degrees	Detents*	Degrees	Detents*
Driver Seat w/Seated Dummy	-12.1 to 43.9	N/A	-7.9	N/A
Front Passenger Seat	-11.0 to 43.5	N/A	-8.1	N/A
Front Center Seat	FIXED	FIXED	FIXED	FIXED
Struck Side Rear Seat	FIXED	FIXED	FIXED	FIXED
Non-Struck Side Rear Seat	FIXED	FIXED	FIXED	FIXED
Rear Center Seat	FIXED	FIXED	FIXED	FIXED

SEAT BELT ANCHORAGE ADJUSTMENT

Seat belt anchorages are adjusted in accordance with the information provided by the manufacturer on Form No. 1. Zero is defined as the uppermost detent

Seat	Total # of Positions	Placed in Position #
Driver Seat	5 (0-4)	0

HEAD RESTRAINT ADJUSTMENT

The driver's head restraint is adjusted to the lowest and most full forward in-use position.

Seat	Total # of Positions	Placed in Position #
Driver Seat	3 (0-2)	Lowermost

DATA SHEET NO. 2 ... (CONTINUED)
SEAT, SEAT BELT, STEERING WHEEL ADJUSTMENT AND FUEL SYSTEMS DATA

Test Vehicle: 2020 Ram 1500 Classic Crew Cab Truck
 Test Program: NCAP Side Pole Impact Test

NHTSA No.: M20200311
 Test Date: 8/25/2020

STEERING COLUMN ADJUSTMENT

Steering wheel and column adjustments are made so that the steering wheel hub is at the center of its geometric locus it describes when it moves through its full range of motion.

	Degrees	Fore / Aft Position (mm)
Lowermost – Position 1	14.2	
Geometric Center – Position 2	21.8	
Uppermost – Position 3	31.2	
Telescoping Steering Wheel Travel		N/A
Test Position	21.8	N/A

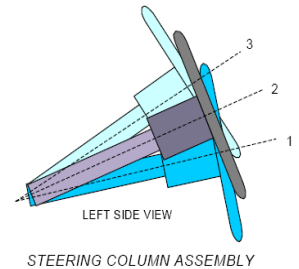

FUEL PUMP

Describe the fuel pump type, details about how it operates, and the location of the fuel filler neck.

The vehicle is equipped with an electric fuel pump.
The fuel filler neck is on the left side of the vehicle.
The pump creates positive pressure in the fuel lines, pushing the gasoline to the engine. See form 1 for more information.

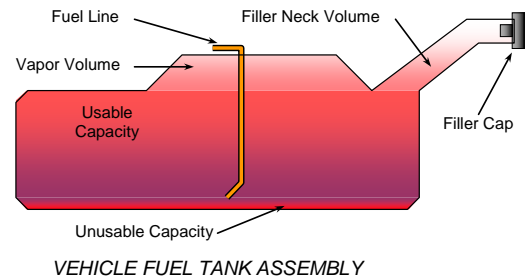

FUEL TANK CAPACITY DATA

Description	Liters
Usable Capacity of "Standard Tank" - see Form No. 1	98.4
Usable Capacity of "Optional Tank" - see Form No. 1	121.2
Usable Capacity of "Standard Tank" - see Owner's Manual	98.4
Usable Capacity of "Optional Tank" - see Owner's Manual	121.2
93% of Usable Capacity	91.5
Actual Amount of Solvent Used in Test	92.4
1/3 of Usable Capacity	32.8

Is the Actual Amount of Solvent Used in the test equal to 93% ±1% of the Usable Capacity stated in Form No. 1?

Yes No

**DATA SHEET NO. 3
DUMMY LONGITUDINAL CLEARANCE DIMENSIONS**

Test Vehicle: 2020 Ram 1500 Classic Crew Cab Truck
 Test Program: NCAP Side Pole Impact Test

NHTSA No.: M20200311
 Test Date: 8/25/2020

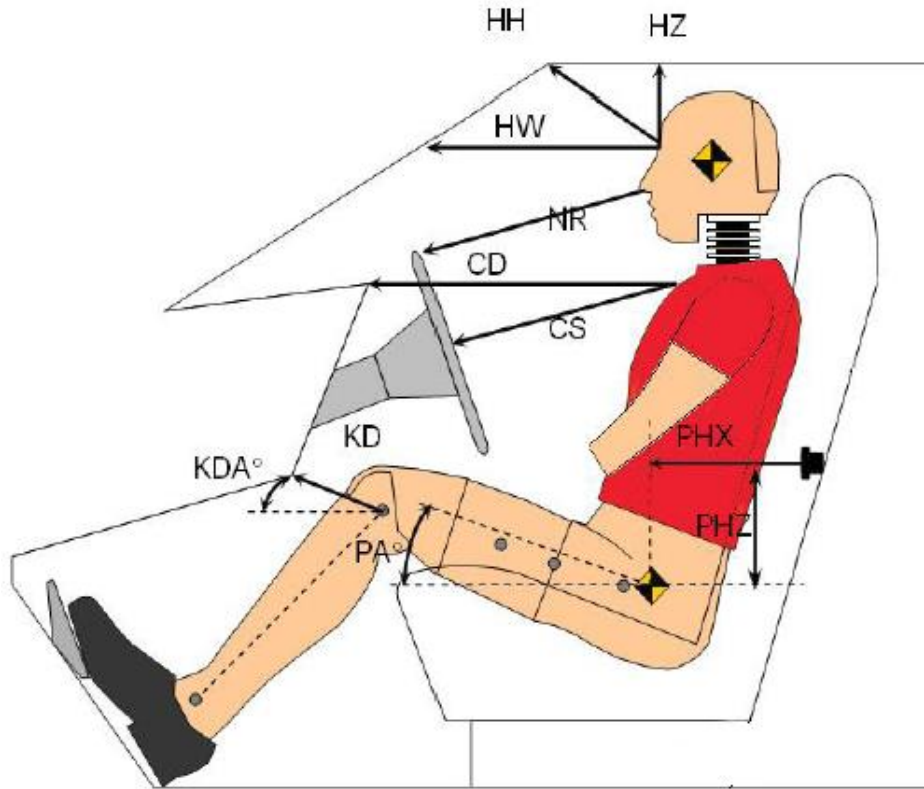

Left Side View

DUMMY LONGITUDINAL CLEARANCE DIMENSION INFORMATION

Driver Code	Description	Driver (Serial No. DG8012)	
		Length (mm)	Angle (°)
HH	Head to Header	335	
HW	Head to Windshield	587	
HZ	Head to Roof Liner	224	
NR	Nose to Rim	210	
CD	Chest to Dash	419	
CS	Chest to Steering Wheel	184	
KD(L) / KDA(L)°	Left Knee to Dash	82	30.5
KD(R) / KDA(R)°	Right Knee to Dash	70	29.9
PAX°	Pelvic Tilt Angle (X-Axis)		19.2
PAY°	Pelvic Tilt Angle (Y-Axis)		0.2
PHX	Hip Point to Striker (X-Axis)	341	
PHZ	Hip Point to Striker (Z-Axis)	17	

**DATA SHEET NO. 4
DUMMY LATERAL CLEARANCE DIMENSIONS**

Test Vehicle: 2020 Ram 1500 Classic Crew Cab Truck
 Test Program: NCAP Side Pole Impact Test

NHTSA No.: M20200311
 Test Date: 8/25/2020

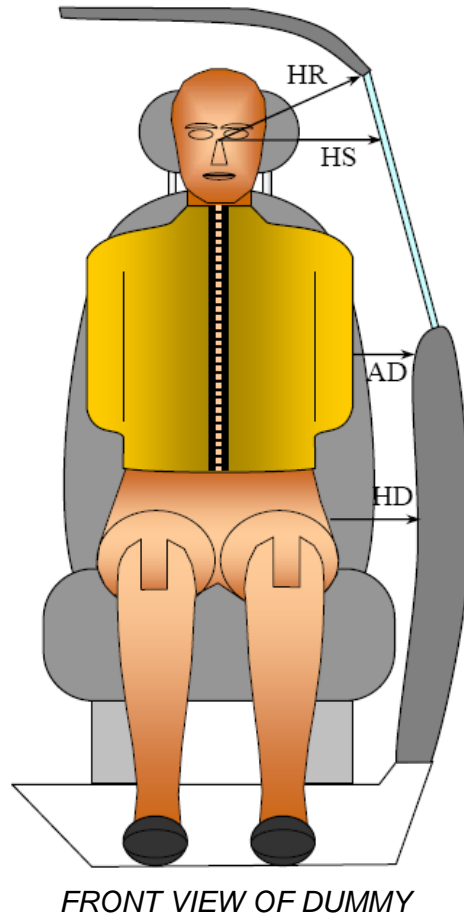

DUMMY LATERAL CLEARANCE DIMENSION INFORMATION

Code	Measurement Description	Units	Driver - Length (Serial No. DG8012)
HR	Head To Side Header	mm	251
HS	Head to Side Window	mm	363
AD	Arm to Door	mm	150
HD	Hip Point to Door	mm	172

**DATA SHEET NO. 5
CAMERA AND INSTRUMENTATION DATA**

Test Vehicle: 2020 Ram 1500 Classic Crew Cab Truck
 Test Program: NCAP Side Pole Impact Test

NHTSA No.: M20200311
 Test Date: 8/25/2020

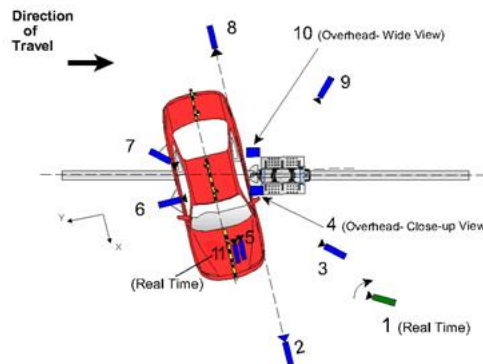

CAMERA LOCATIONS AND DATA

No.	Camera View	Coordinates (mm)			Lens Length (mm)	Operating Frame Rate (fps)
		X	Y	Z		
1	Real-time (24 - 30 fps) pan view of impact				Zoom	60
2	Front ground level - impact view	7858	0	-1579	28	1000
3	Impact side 45° - forward pole view	5327	-1308	-1596	24	1000
4	Overhead Close-up view of impact	0	0	9230	50	1000
5	Onboard - dummy front view				25	1000
6	Onboard - dummy side view				12.5	1000
7	Onboard - dummy rear oblique view				8	1000
8	Rear ground level - impact view	-9441	0	-1588	28	1000
9	Impact side 45° - rearward pole view	-5404	-4014	-1783	24	1000
10	Overhead wide - view of impact	0	0	9230	12.5	1000
11	Real-time (24 - 30 fps) - dummy front view				Zoom	60

Notes: Reference - From Point of Impact for X and Y; from Ground for Z
 +X = Forward of vehicle, +Y = Right of vehicle, +Z = Down
 * All measurements accurate to ± 6 mm. Vehicle is at a 75° angle to the rigid pole.

Comments: All cameras operated as intended.

INSTRUMENTATION

Description	Number of Channels
Driver Dummy Channels	16
Vehicle Structure Accelerometers	18
Pole Load Cells	8
Total	42

DATA SHEET NO. 6
VEHICLE ACCELEROMETER DATA

Test Vehicle: 2020 Ram 1500 Classic Crew Cab Truck
 Test Program: NCAP Side Pole Impact Test

NHTSA No.: M20200311
 Test Date: 8/25/2020

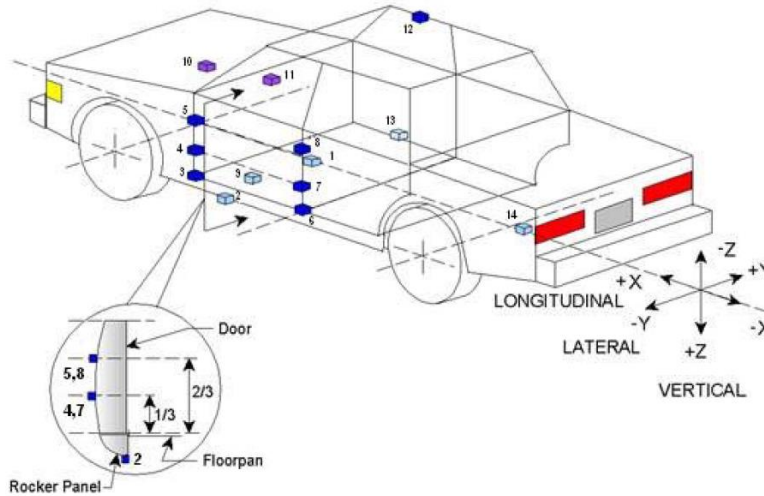

TEST VEHICLE ACCELEROMETER LOCATIONS

No.	Accelerometer Location	Coordinates (mm)		
		X	Y	Z
1	Vehicle CG	3788	-4	-205
2	Left Floor Sill	3720	-816	-42
3	A-Pillar Sill	4234	-749	-88
4	A-Pillar Low	4232	-771	-270
5	A-Pillar Mid	4164	-746	-833
6	B-Pillar Sill	3180	-752	-80
7	B-Pillar Low	3137	-781	-421
8	B-Pillar Mid	3062	-782	-741
9	Driver Seat Track	3386	-645	-149
10	Engine Top	4802	39	-556
11	Firewall	4458	504	-558
12	Right Roof	3162	681	-1325
13	Right Floor Sill	3718	815	-40
14	Rear Floorpan	1018	-3	-291

Reference: X – Rear surface of vehicle (+ forward)
 Y – Vehicle centerline (+ to right)
 Z – Ground plane (+ down)

**DATA SHEET NO. 7
RIGID POLE LOAD CELL DATA**

Test Vehicle: 2020 Ram 1500 Classic Crew Cab Truck
Test Program: NCAP Side Pole Impact Test

NHTSA No.: M20200311
Test Date: 8/25/2020

POLE BARRIER



RIGID POLE LOAD CELL LOCATIONS

ID	Units	Height From Ground
1	mm	200
2	mm	590
3	mm	750
4	mm	1075
5	mm	1260
6	mm	1740
7	mm	1920
8	mm	2300

**DATA SHEET NO. 8
POST-TEST OBSERVATIONS**

Test Vehicle: 2020 Ram 1500 Classic Crew Cab Truck
 Test Program: NCAP Side Pole Impact Test

NHTSA No.: M20200311
 Test Date: 8/25/2020

TEST DUMMY INFORMATION AND CONTACT POINTS

Dummy Body Part	Driver Seat Dummy (SID-IIs)
Face	Curtain Airbag
Top of Head	Curtain Airbag
Left Side of Head	Curtain Airbag
Back of Head	Curtain Airbag & Headrest
Left Shoulder	Torso/Pelvis Airbag
Upper Torso	Seatback & Torso/Pelvis Airbag
Lower Torso	Seatback & Torso/Pelvis Airbag
Left Hip	Seat pan & Torso/Pelvis Airbag
Left Knee	Driver Door

POST-TEST DOOR PERFORMANCE

Description	Struck Side		Non-Struck Side		Rear Hatch/Other
	Front	Rear	Front	Rear	
Remained Closed and Operational	No	No	No	Yes	Yes
Total Separation from Vehicle at Hinges or Latches	No	No	No	No	No
Latch or Hinge Systems Pulled Out of Their Anchorages	No	No	No	No	No
Disengaged from Latched Position	No	No	No	No	No
Latch Separated from Striker	No	No	No	No	No
Jammed Shut	Yes	Yes	Yes	No	No
If Door Opened at Striker, Width of Opening at Striker (mm)	0	0	0	0	0

POST-TEST SEAT PERFORMANCE

Description	Struck Side		Non-Struck Side	
	Front	Rear	Front	Rear
Seat Movement Along Seat Track	No	No	No	No
Seat Disengagement from Floor Pan	No	No	No	No
Seat Back Movement from Initial Position	No	No	No	No
Seat Back Collapse	No	No	No	No

**DATA SHEET NO. 8 ... (CONTINUED)
POST-TEST OBSERVATIONS**

Test Vehicle: 2020 Ram 1500 Classic Crew Cab Truck
 Test Program: NCAP Side Pole Impact Test

NHTSA No.: M20200311
 Test Date: 8/25/2020

POST-TEST STRUCTURAL OBSERVATIONS

Critical Areas of Performance	Observations and Conclusions
Pillar Performance	A-Pillar Buckled
Sill Separation	None
Windshield Damage	Cracks throughout
Side Window Damage	Driver window shattered
Other Notable Effects	Intrusion of Pole caused Front Seats to deform where front passenger door had to be opened with force and will not reclose easily due to seat interference – thus, the door did not remain closed and operational

SUPPLEMENTAL RESTRAINT SYSTEM INFORMATION

Restraint Type	Struck Side Driver		Struck Side Rear Passenger	
	Mounted	Deployed	Mounted	Deployed
Frontal Airbag	Yes	No		
Knee Airbag	No	N/A		
Side Airbag 1 - Curtain	Yes	Yes	Yes	Yes
Side Airbag 2 – Torso/Pelvis	Yes	Yes	No	N/A
Seat Belt Pretensioner	Yes	Yes	No	N/A
Seat Belt Load Limiter	Yes	Yes	No	N/A
Other				

VEHICLE SPEED, VEHICLE ANGLE AT IMPACT AND IMPACT POINT LOCATION DATA

Measured Parameter	Units	Tolerance	Value
Vertical Impact Ref Line - Aft of Front Axle, Intended Impact Pt	mm		1170
Actual Impact Point - Aft of Front Axle	mm		1168
Horizontal Offset (+ forward / - rearward)	mm	+/- 38 *	+2
Angle Between Vehicle's Longitudinal Centerline and Line of Forward Motion	deg	75 +/- 3	75.0
Trap No. 1 Velocity - Primary	kph	31.4 to 33.0	32.00
Trap No. 2 Velocity - Redundant	kph	31.4 to 33.0	32.04

* Of Intended Impact Point

DATA SHEET NO. 9
TEST VEHICLE PROFILE MEASUREMENTS

Test Vehicle: 2020 Ram 1500 Classic Crew Cab Truck
Test Program: NCAP Side Pole Impact Test

NHTSA No.: M20200311
Test Date: 8/25/2020

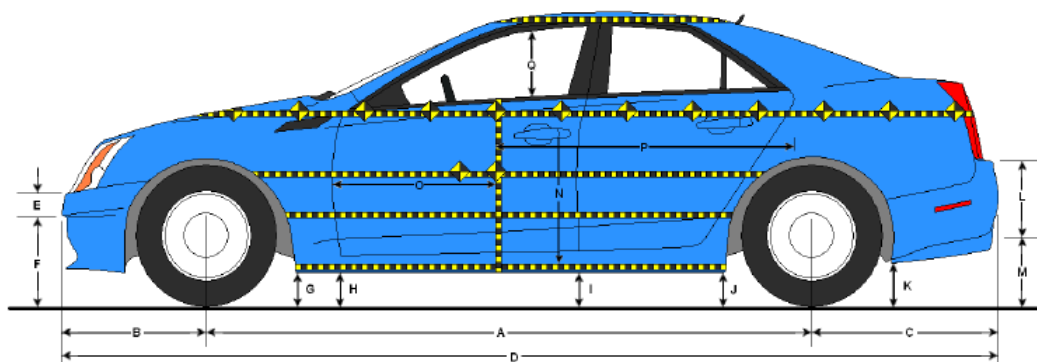

LEFT SIDE VIEW

VEHICLE PRE- AND POST-TEST MEASUREMENT INFORMATION

Code	Description	Pre-Test	Post-Test	Difference
A	Vehicle Wheelbase	3569	3498	71
B	Front Axle to FSOV	1035	1102	-67
C	Rear Axle to RSOV	1233	1190	43
D	Total Length at Centerline	5836	5790	46
E	Front Bumper Thickness	500	500	0
F	Front Bumper Bottom to Ground	297	302	-5
G	Sill Height at Front Wheel Well	343	320	23
H	Sill Height at Front Door Leading Edge	350	339	11
I	Sill Height at B-Pillar	360	367	-7
J1	Sill Height at Rear Wheel Well	342	371	-29
J2	Pinch Weld Height at Rear Wheel Well	370	384	-14
K	Sill Height Aft of Rear Wheel Well	435	468	-33
L	Rear Bumper Thickness	250	250	0
M	Rear Bumper Bottom to Ground	498	532	-34
N	Sill Height to Bottom of Front Window Sill	944	946	-2
O	Front Door Leading Edge to Impact CL	663	544	119
P	Rear Door Trailing Edge to Impact CL	1474	1361	113
Q	Front Window Opening	469	472	-3
R	Right Side Length	5778	5756	22
S	Left Side Length	5772	5719	53
T	Vehicle Width at B-Pillars	2014	1895	119

* All measurements in mm with tolerance of $\pm 3\text{mm}$

**DATA SHEET NO. 10
TEST VEHICLE EXTERIOR CRUSH MEASUREMENTS**

Test Vehicle: 2020 Ram 1500 Classic Crew Cab Truck
 Test Program: NCAP Side Pole Impact Test

NHTSA No.: M20200311
 Test Date: 8/25/2020

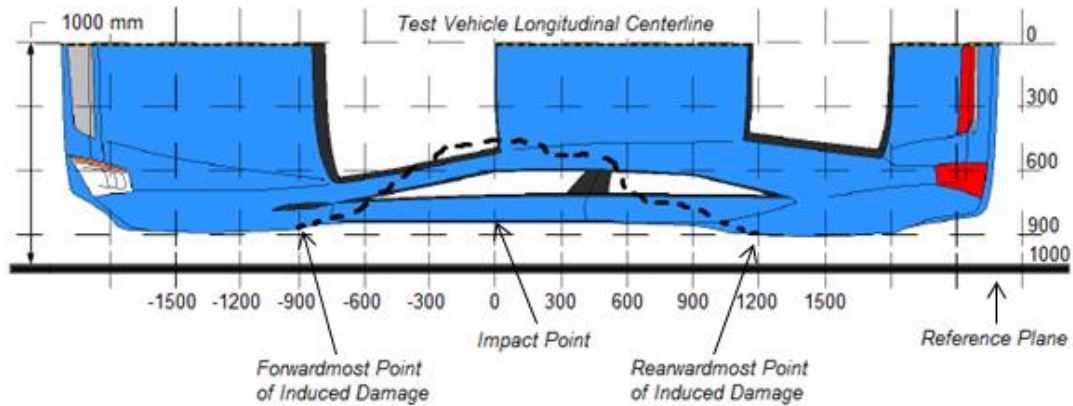
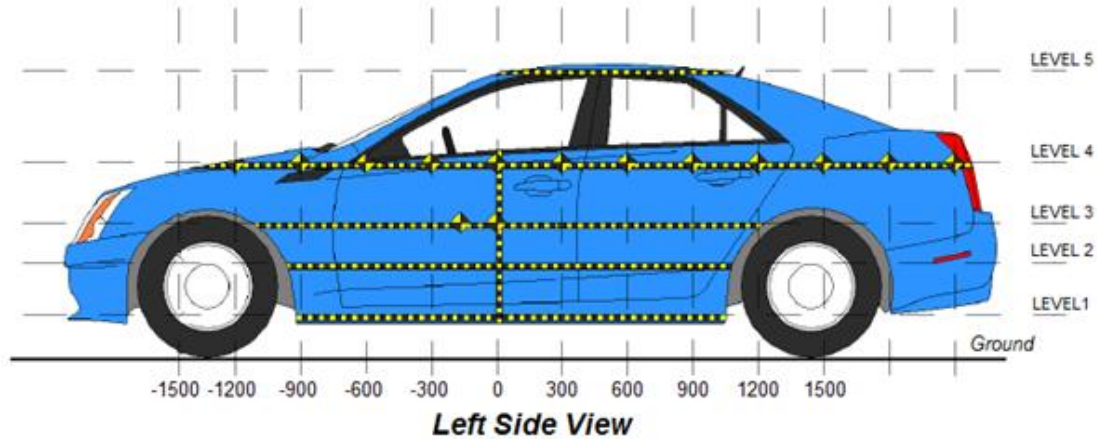

MAXIMUM EXTERIOR CRUSH MEASUREMENTS

Level	Measurement Description	Units	Height Above Ground	Maximum Exterior Static Crush	Distance from Impact
1	Sill Top	mm	428	375	0
2	Occupant Hip Point	mm	958	441	150
3	Mid - Door	mm	877	435	150
4	Window Sill	mm	1282	371	150
5	Window Top	mm	1854	164	150

NOTE: The above measurements should be taken along the vertical impact reference line. Vehicle measurements forward of the vertical impact reference line are negative.

DATA SHEET NO. 10 ... (CONTINUED)
TEST VEHICLE EXTERIOR CRUSH MEASUREMENTS

Test Vehicle: 2020 Ram 1500 Classic Crew Cab Truck
 Test Program: NCAP Side Pole Impact Test

NHTSA No.: M20200311
 Test Date: 8/25/2020

EXTERIOR CRUSH MEASUREMENTS AT EACH LEVEL

	Pre-Test					Post-Test					Difference				
	1	2	3	4	5	1	2	3	4	5	1	2	3	4	5
-1500															
-1350															
-1200															
-1050															
-900			1031	893				1056	938				-25	-45	
-750		1018	1008	905			1030	1018	921			-12	-10	-16	
-600	934	1010	1007	914		915	977	972	897		19	33	35	17	
-450	926	1008	1006	920		794	881	876	839		132	127	130	81	
-300	928	1007	1005	927		715	784	779	766		213	223	226	161	
-150	928	1006	1005	931		634	688	684	671		294	318	321	260	
0	929	1006	1005	937		554	581	580	576		375	425	425	361	
150	929	1006	1006	941	704	584	565	571	570	540	345	441	435	371	164
300	929	1007	1008	946	717	707	682	684	687	614	222	325	324	259	103
450	929	1009	1009	949	723	767	827	830	814	669	162	182	179	135	54
600	928	1011	1011	953	727	796	906	902	870	700	132	105	109	83	27
750	927	1012	1012	955	731	823	926	921	890	716	104	86	91	65	15
900	926	1013	1012	958	732	842	945	940	911	720	84	68	72	47	12
1050	926	1013	1012	960	732	860	964	958	932	721	66	49	54	28	11
1200	926	1012	1011	962	732	878	982	976	951	721	48	30	35	11	11
1350		1011	1010	960	731		1000	994	969	725		11	16	-9	6
1500			1007	959				1011	986				-4	-27	

NOTE: Pre-test measurements are taken when the vehicle is in the “As Tested” weight condition. Vehicle measurements forward of the vertical impact reference line are negative. The crush profile grid is established prior to the test based on an estimated impact point. The final distance from impact is determined after the final dummy positioning and the pole is aligned with the center of gravity of the dummy’s head.

DATA SHEET NO. 10 ... (CONTINUED)
TEST VEHICLE EXTERIOR CRUSH MEASUREMENTS

Test Vehicle: 2020 Ram 1500 Classic Crew Cab Truck
 Test Program: NCAP Side Pole Impact Test

NHTSA No.: M20200311
 Test Date: 8/25/2020

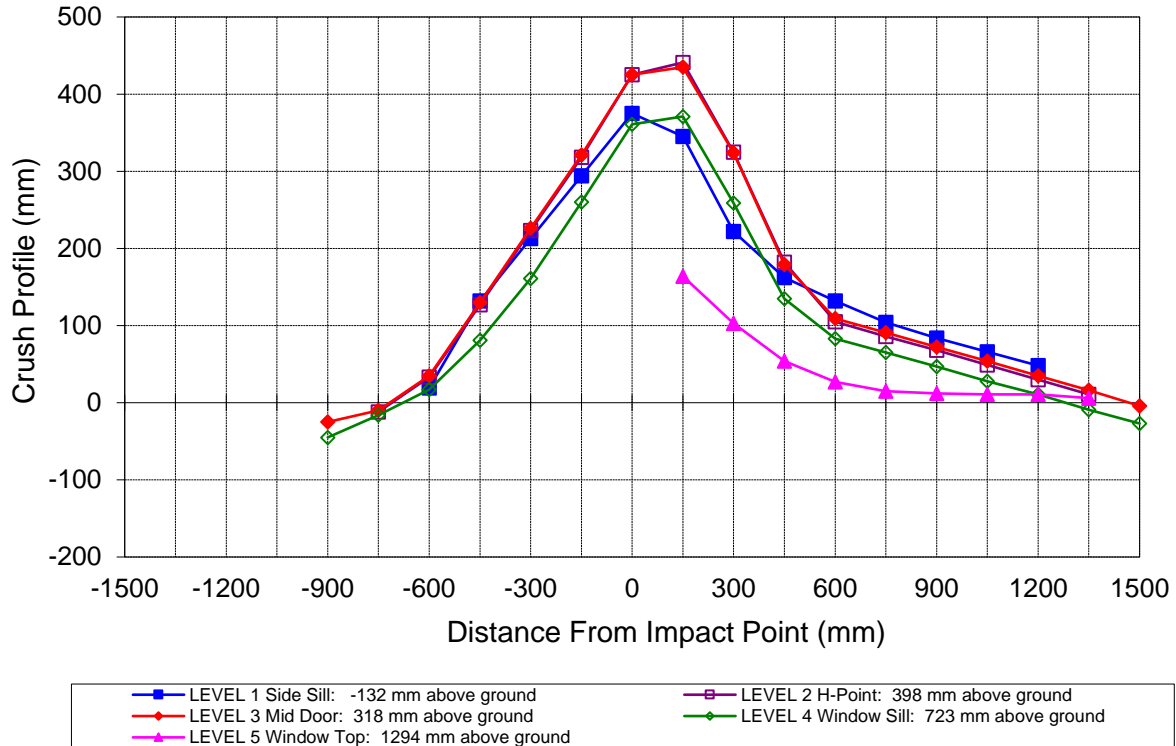

Vehicle Exterior Crush Measurements - Visual Representation

DATA SHEET NO. 11
VEHICLE DAMAGE PROFILE DISTANCES

Test Vehicle: 2020 Ram 1500 Classic Crew Cab Truck
Test Program: NCAP Side Pole Impact Test

NHTSA No.: M20200311
Test Date: 8/25/2020

For guidance regarding damage profile distance measurements, please refer to the latest version of the *NHTSA Test Reference Guide, Volume 1: Vehicle Tests*.

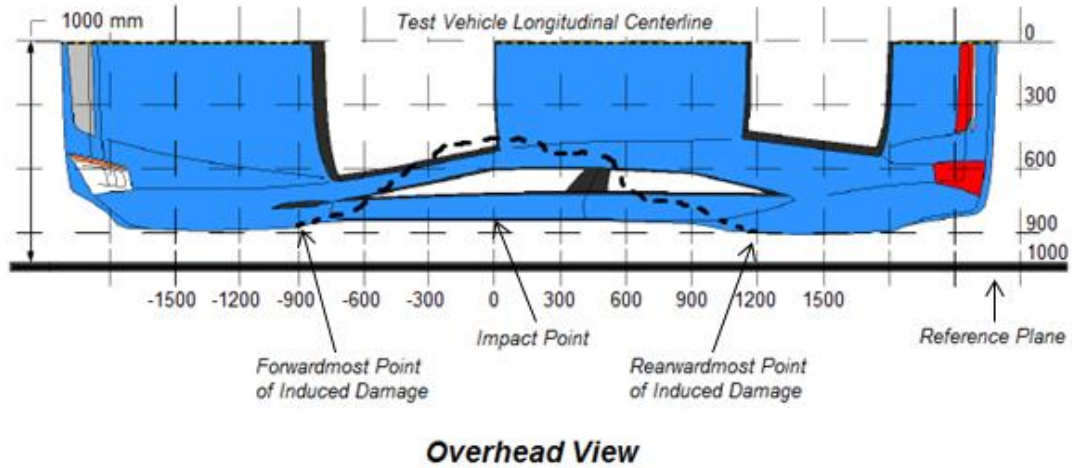

VEHICLE DAMAGE PROFILE DISTANCES

DPD	Distance From Impact Point (mm)	Level	Post-Test (mm)	Pre-Test (mm)	Crush (mm)
1	-900	3	-56	-31	-25
2	-420	3	143	-6	149
3	60	3	424	-5	429
4	540	3	127	-10	137
5	1020	3	46	-12	58
6	1500	3	-11	-7	-4

**DATA SHEET NO. 12
FMVSS NO. 301 STATIC ROLLOVER RESULTS**

Test Vehicle:	<u>2020 Ram 1500 Classic Crew Cab Truck</u>	NHTSA No.:	<u>M20200311</u>
Test Program:	<u>NCAP Side MDB Impact Test</u>	Test Date:	<u>8/25/2020</u>
Test Time:	<u>8:35 AM</u>	Temperature:	<u>21° C</u>

- A. From impact until vehicle motion ceases: 0 oz.
(Maximum allowable is 1 oz.)
- B. For the 5-minute period after motion ceases: 0 oz.
(Maximum allowable is 5 oz.)
- C. For the following 25 minutes: 0 oz.
(Maximum allowable is 1 oz./minute)
- D. Spillage Details: No Spillage Occurred

FMVSS NO. 301 STATIC ROLLOVER DATA



ROLLOVER SOLVENT COLLECTION TIME TABLE IN SECONDS

Test Phase	Rotation Time	Hold Time	Total Time
0° to 90°	72	300	372
90° to 180°	71	300	371
180° to 270°	70	300	370
270° to 360°	70	300	370

FMVSS NO. 301 ROLLOVER SPILLAGE TABLE

Test Phase	First 5 Minutes	Sixth Minute	Seventh Minute	Eighth Minute
0° to 90°	0	0	0	0
90° to 180°	0	0	0	0
180° to 270°	0	0	0	0
270° to 360°	0	0	0	0

ROLLOVER SOLVENT SPILLAGE LOCATION TABLE

Test Phase	Spillage Location
0° to 90°	No Spillage Occurred
90° to 180°	No Spillage Occurred
180° to 270°	No Spillage Occurred
270° to 360°	No Spillage Occurred

DATA SHEET NO. 13
DUMMY / VEHICLE TEMPERATURE AND HUMIDITY STABILIZATION DATA

Test Vehicle: 2020 Ram 1500 Classic Crew Cab Truck
Test Program: NCAP Side Pole Impact Test

NHTSA No.: M20200311
Test Date: 8/25/2020

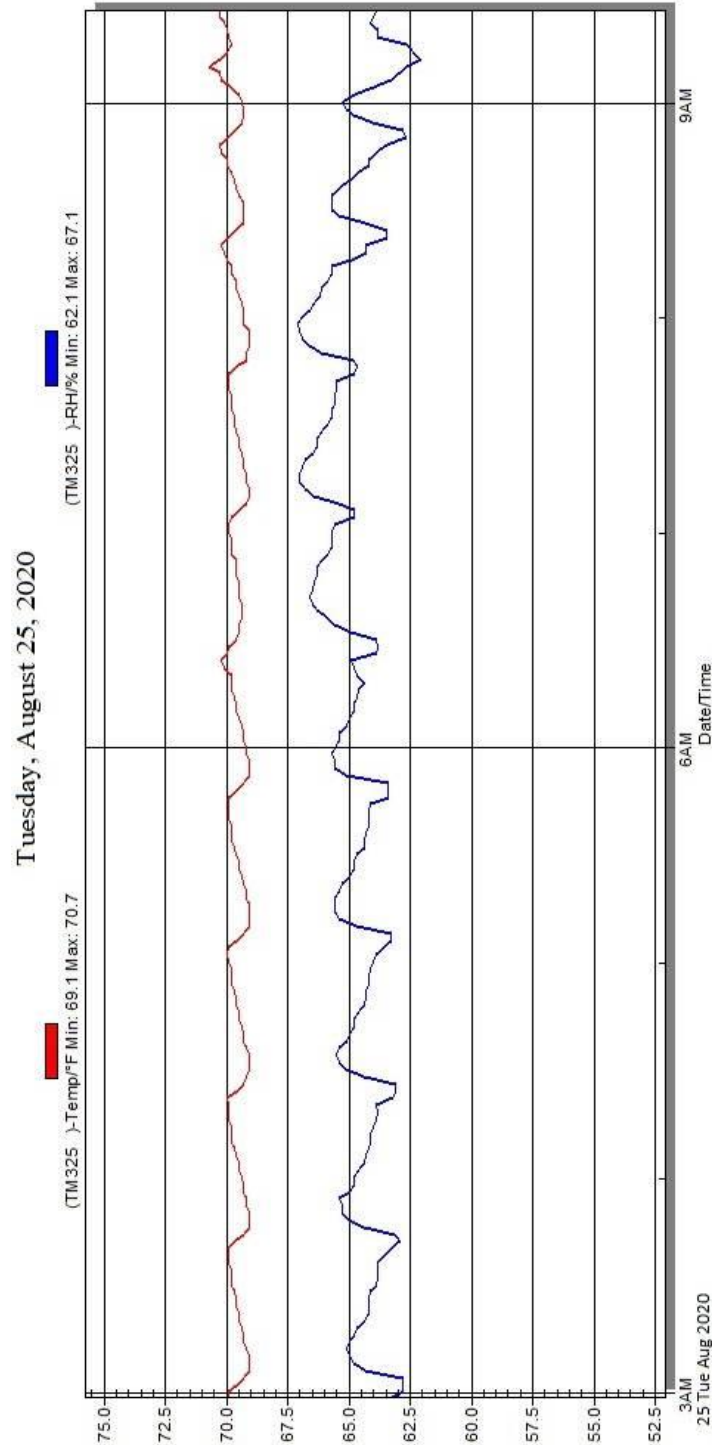

Temperature and Humidity Stabilization Chart / Data for Dummies and Test Vehicle

APPENDIX A
PHOTOGRAPHS

TABLE OF PHOTOGRAPHS

Fig.	Description	Page
1	As Delivered Right Front $\frac{3}{4}$ View of Test Vehicle	A-4
2	As Delivered Left Rear $\frac{3}{4}$ View of Test Vehicle	A-4
3	Pre-Test Frontal View of Test Vehicle	A-5
4	Post-Test Frontal View of Test Vehicle	A-5
5	Pre-Test Left Front $\frac{3}{4}$ View of Test Vehicle	A-6
6	Post-Test Left Front $\frac{3}{4}$ View of Test Vehicle	A-6
7	Pre-Test Left Side View of Test Vehicle	A-7
8	Post-Test Left Side View of Test Vehicle	A-7
9	Pre-Test Left Rear $\frac{3}{4}$ View of Test Vehicle	A-8
10	Post-Test Left Rear $\frac{3}{4}$ View of Test Vehicle	A-8
11	Pre-Test Rear View of Test Vehicle	A-9
12	Post-Test Rear View of Test Vehicle	A-9
13	Pre-Test Right Side View of Test Vehicle	A-10
14	Post-Test Right Side View of Test Vehicle	A-10
15	Pre-Test Overhead View of Test Area	A-11
16	Post-Test Overhead View of Test Area	A-11
17	Pre-Test Left Side View of Pole Positioned Against Side of Vehicle	A-12
18	Pre-Test Right Side View of Pole Positioned Against Side of Vehicle	A-12
19	Pre-Test Close-Up View of Impact Point Target	A-13
20	Post-Test Close-Up View of Impact Point Target Showing Impact Location	A-13
21	Pre-Test Front Close-Up View of Dummy Head and Chest	A-14
22	Post-Test Front Close-Up View of Dummy	A-14
23	Pre-Test Left Side View of Dummy Showing Belt and Chalking	A-15
24	Pre-Test Left Side View of Dummy Shoulder and Door Top View	A-15
25	Post-Test Left Side View of Dummy Shoulder and Door Top View	A-16
26	Pre-Test Frontal View of Seat Back Prior to Dummy Positioning	A-16
27	Pre-Test Frontal Close-Up View of Dummy Head / Shoulders in Relation to Head Restraint	A-17
28	Pre-Test Frontal View of Seat Pan Prior to Dummy Positioning	A-17
29	Pre-Test Overhead View of Dummy Thighs on Seat Pan	A-18
30	Pre-Test Left Side View of Dummy's Neck Showing Position of Adjustable Neck Bracket	A-18
31	Pre-Test Left Side View of Dummy's Head Showing Dummy's Head is Level	A-19
32	Pre-Test Placement of Dummy's Feet	A-19
33	Pre-Test View of Belt Anchorage for Dummy	A-20
34	Pre-Test Left Side View of Steering Wheel	A-20
35	Pre-Test View of Disengaged Parking Brake	A-21

Fig.	Description	Page
36	Pre-Test View of Parking Brake	A-21
37	Pre-Test Close-Up Left Side View of Driver Seat Track	A-22
38	Pre-Test Close-Up Left Side View of Driver Seat Back	A-22
39	Pre-Test Close-Up View of Driver Seat Back or Head Restraint	A-23
40	Pre-Test Dummy and Door Clearance View	A-23
41	Post-Test Dummy and Door Clearance View	A-24
42	Pre-Test Right Side View of Dummy and Front Seat of Occupant Compartment	A-24
43	Post-Test Right Side View of Dummy and Front Seat of Occupant Compartment	A-25
44	Pre-Test Inner Door Panel View	A-25
45	Post-Test Inner Door Panel View Showing Dummy Contact Location	A-26
46	Post-Test Dummy Close-Up Head Contact with Vehicle Interior View	A-26
47	Post-Test Dummy Close-Up Head Contact with Side Airbag View	A-27
48	Post-Test Dummy Close-Up Torso Contact with Vehicle Interior View	A-27
49	Post-Test Dummy Close-Up Torso Contact with Side Airbag View	A-28
50	Post-Test Dummy Close-Up Pelvis Contact with Vehicle Interior View	A-28
51	Post-Test Dummy Close-Up Pelvis Contact with Side Airbag View	A-29
52	Post-Test Dummy Close-Up Knee Contact with Vehicle Interior View	A-29
53	Pre-Test View of Fuel Filler Cap or Fuel Filler Neck	A-30
54	Post-Test View of Fuel Filler Cap or Fuel Filler Neck	A-30
55	Close-Up View of Vehicle's Certification Label	A-31
55a	Close-Up View of Reduced Load Capacity Label	A-31
56	Close-Up View of Vehicle's Tire Information Placard or Label	A-32
57	Pre-Test Pole Barrier Front View	A-32
58	Post-Test Pole Barrier Front View	A-33
59	Pre-Test Pole Barrier Side View	A-33
60	Post-Test Pole Barrier Side View	A-34
61	Pre-Test Ballast View	A-34
62	Post-Test Primary and Redundant Speed Trap Read-Out	A-35
63	FMVSS No. 301 Static Rollover 0 Degrees	A-35
64	FMVSS No. 301 Static Rollover 90 Degrees	A-36
65	FMVSS No. 301 Static Rollover 180 Degrees	A-36
66	FMVSS No. 301 Static Rollover 270 Degrees	A-37
67	FMVSS No. 301 Static Rollover 360 Degrees	A-37
68	Impact Event	A-38
69	Monroney Label	A-38
70	Head Restraint Use and Adjustment Information from Vehicle Owner's Manual	A-39
71	Post-Test View of Shattered Vehicle Inner Door Panel	A-39



M20200311

Figure A-1: As Delivered Right Front ¾ View of Test Vehicle



M20200311

Figure A-2: As Delivered Left Rear ¾ View of Test Vehicle

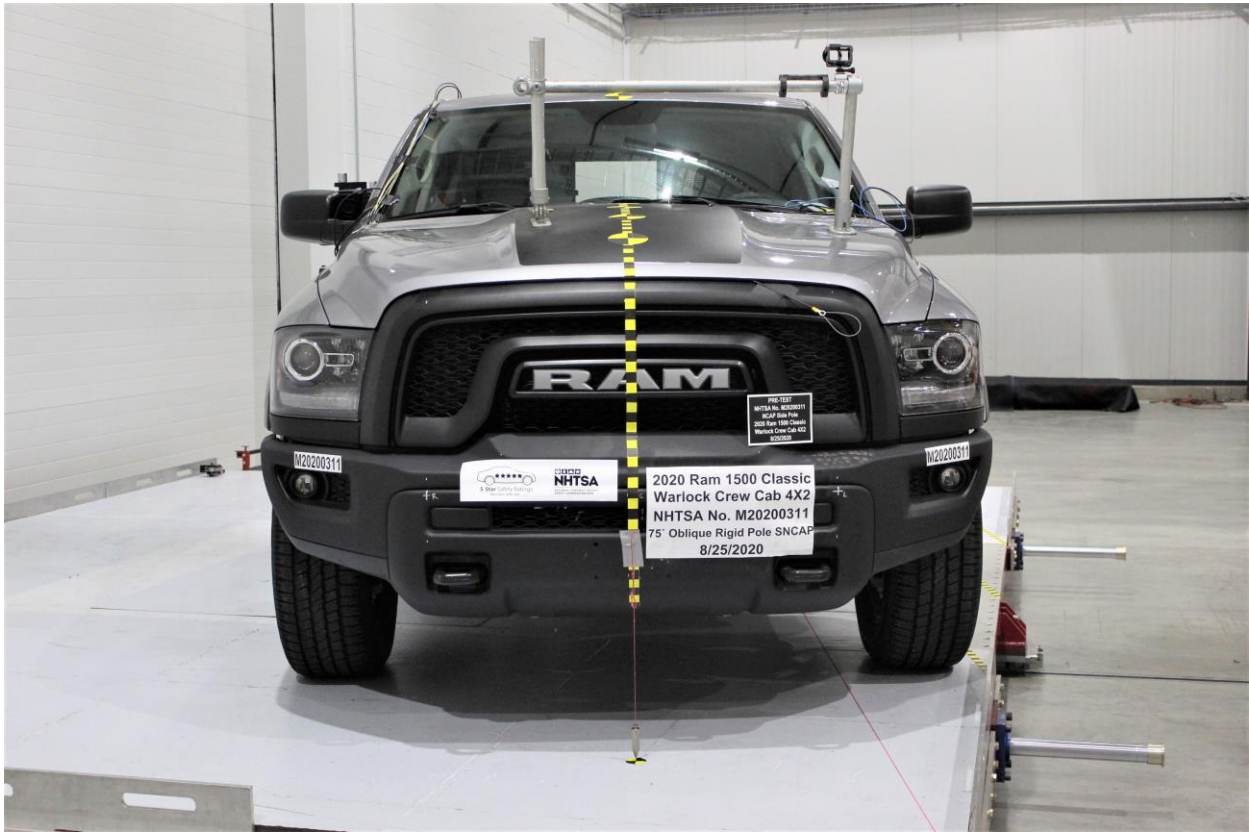

Figure A-3: Pre-Test Frontal View of Test Vehicle

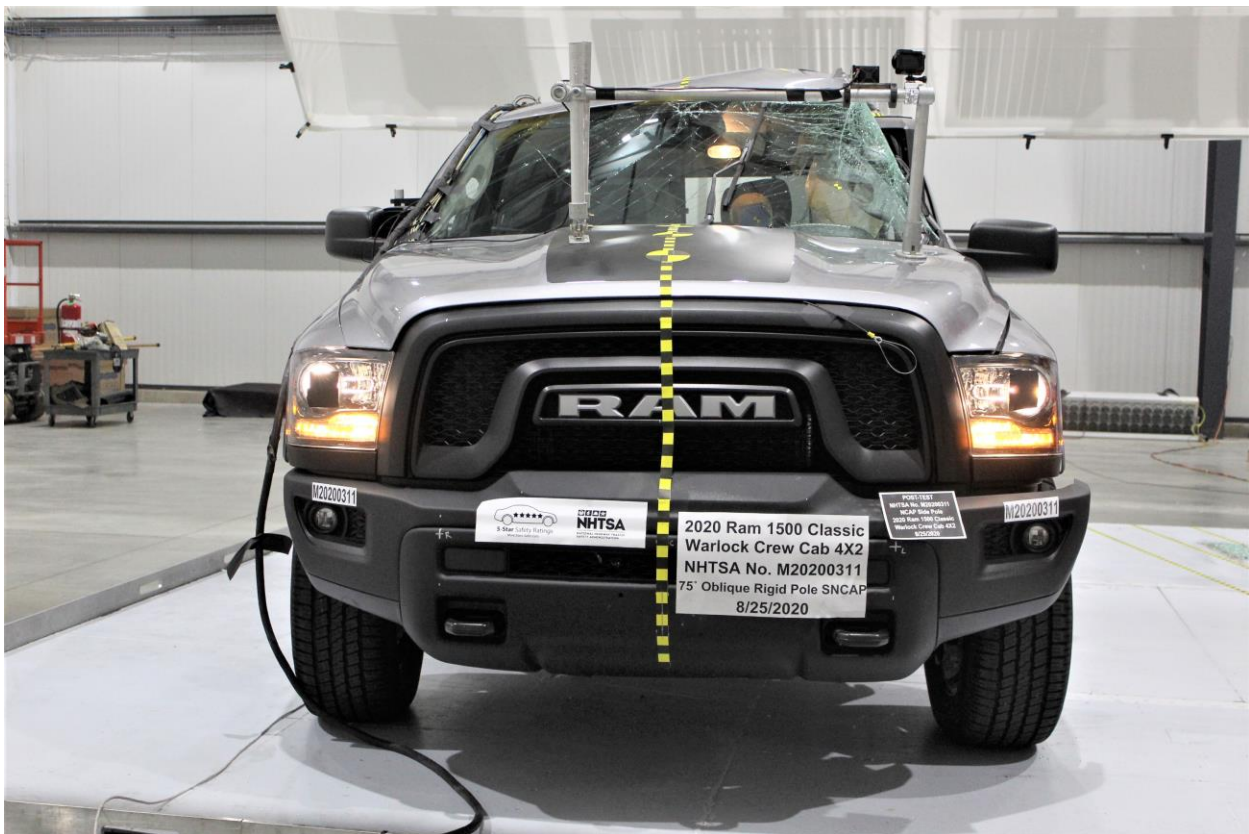

Figure A-4: Post-Test Frontal View of Test Vehicle



Figure A-5: Pre-Test Left Front $\frac{3}{4}$ View of Test Vehicle



Figure A-6: Post-Test Left Front $\frac{3}{4}$ View of Test Vehicle



Figure A-7: Pre-Test Left Side View of Test Vehicle



Figure A-8: Post-Test Left Side View of Test Vehicle

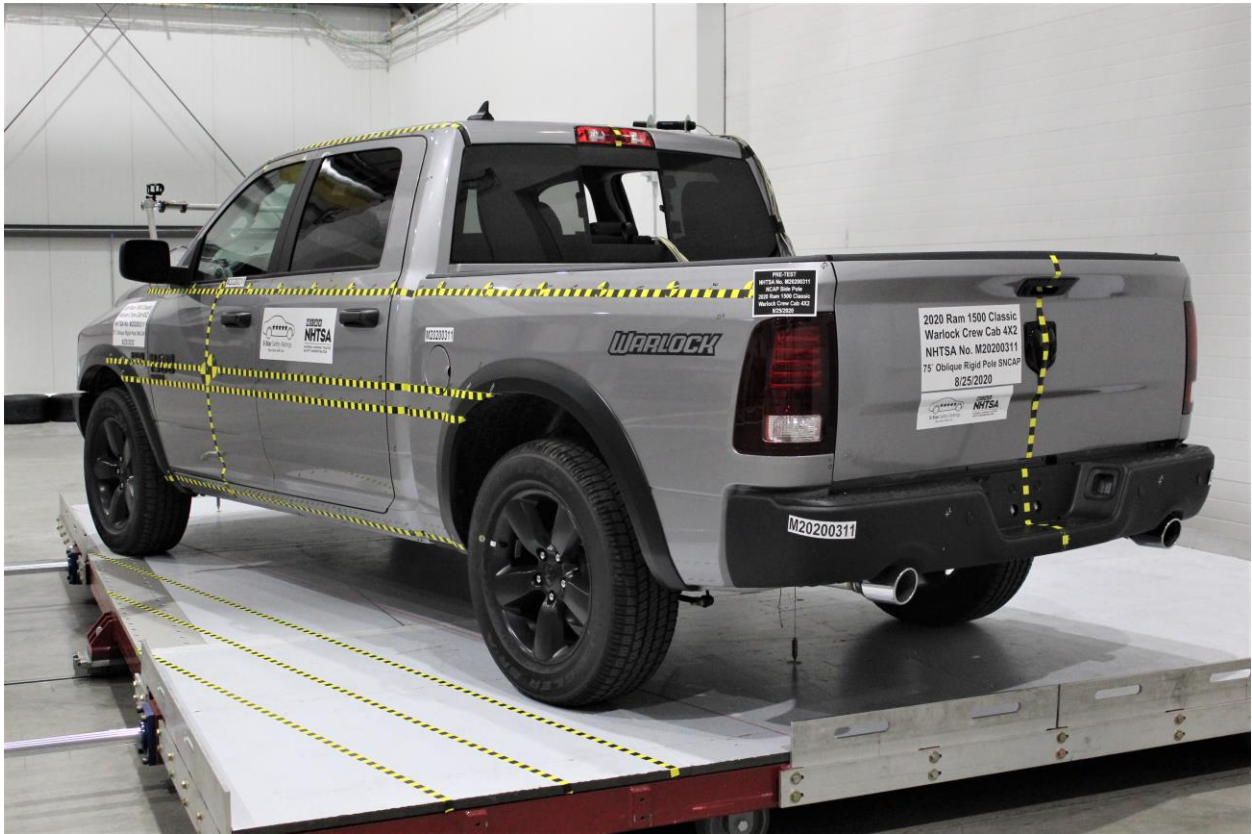

Figure A-9: Pre-Test Left Rear $\frac{3}{4}$ View of Test Vehicle



Figure A-10: Post-Test Left Rear $\frac{3}{4}$ View of Test Vehicle



Figure A-11: Pre-Test Rear View of Test Vehicle



Figure A-12: Post-Test Rear View of Test Vehicle



Figure A-13: Pre-Test Right Side View of Test Vehicle



Figure A-14: Post-Test Right Side View of Test Vehicle

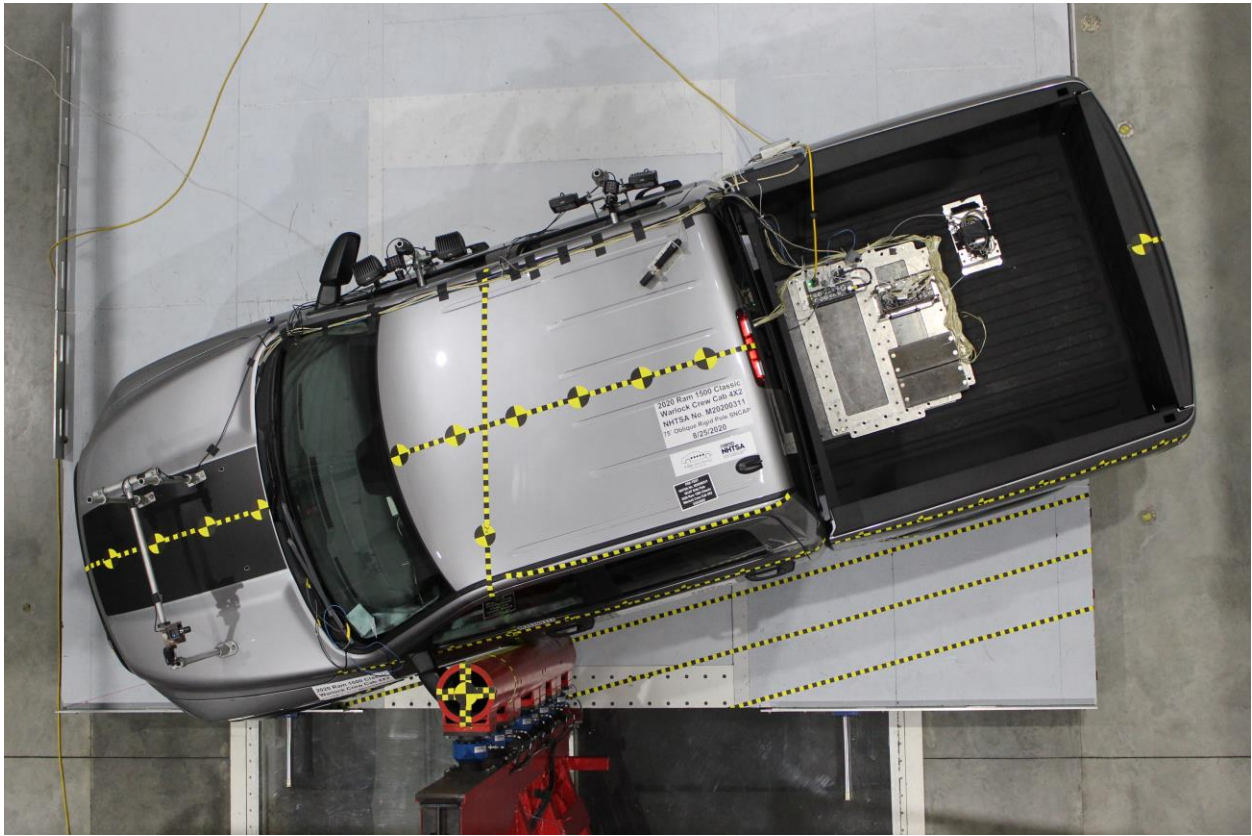

Figure A-15: Pre-Test Overhead View of Test Area

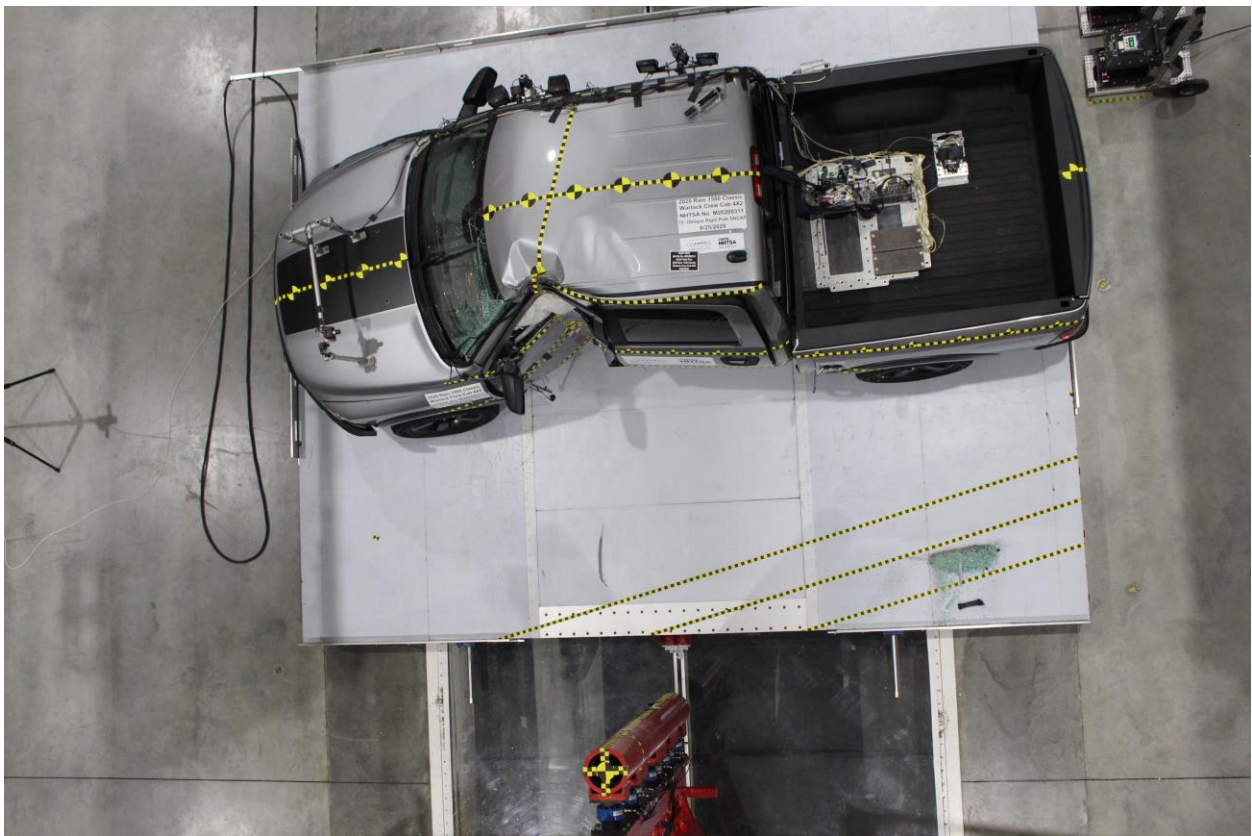

Figure A-16: Post-Test Overhead View of Test Area



Figure A-17: Pre-Test Left Side View of Pole Positioned Against Side of Vehicle

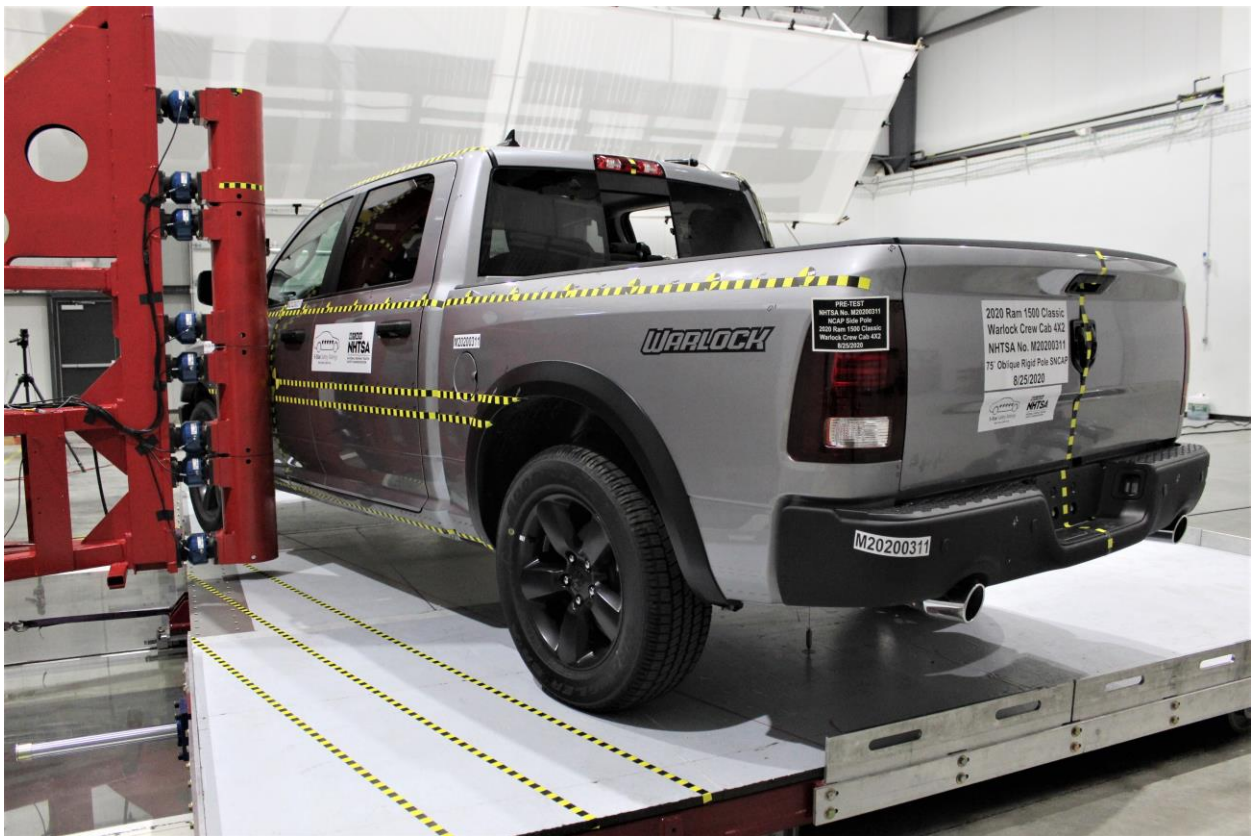

Figure A-18: Pre-Test Right Side View of Pole Positioned Against Side of Vehicle



Figure A-19: Pre-Test Close-Up View of Impact Point Target



Figure A-20: Post-Test Close-Up View of Impact Point Target Showing Impact Location



Figure A-21: Pre-Test Front Close-Up View of Dummy Head and Chest



Figure A-22: Post-Test Front Close-Up View of Dummy



Figure A-23: Pre-Test Left Side View of Dummy Showing Belt and Chalking



Figure A-24: Pre-Test Left Side View of Dummy Shoulder and Door Top View



Figure A-25: Post-Test Left Side View of Dummy Shoulder and Door Top View



Figure A-26: Pre-Test Frontal View of Seat Back Prior to Dummy Positioning



Figure A-27: Pre-Test Frontal Close-Up View of Dummy Head / Shoulders in Relation to Head Restraint



Figure A-28: Pre-Test Frontal View of Seat Pan Prior to Dummy Positioning



Figure A-29: Pre-Test Overhead View of Dummy Thighs on Seat Pan

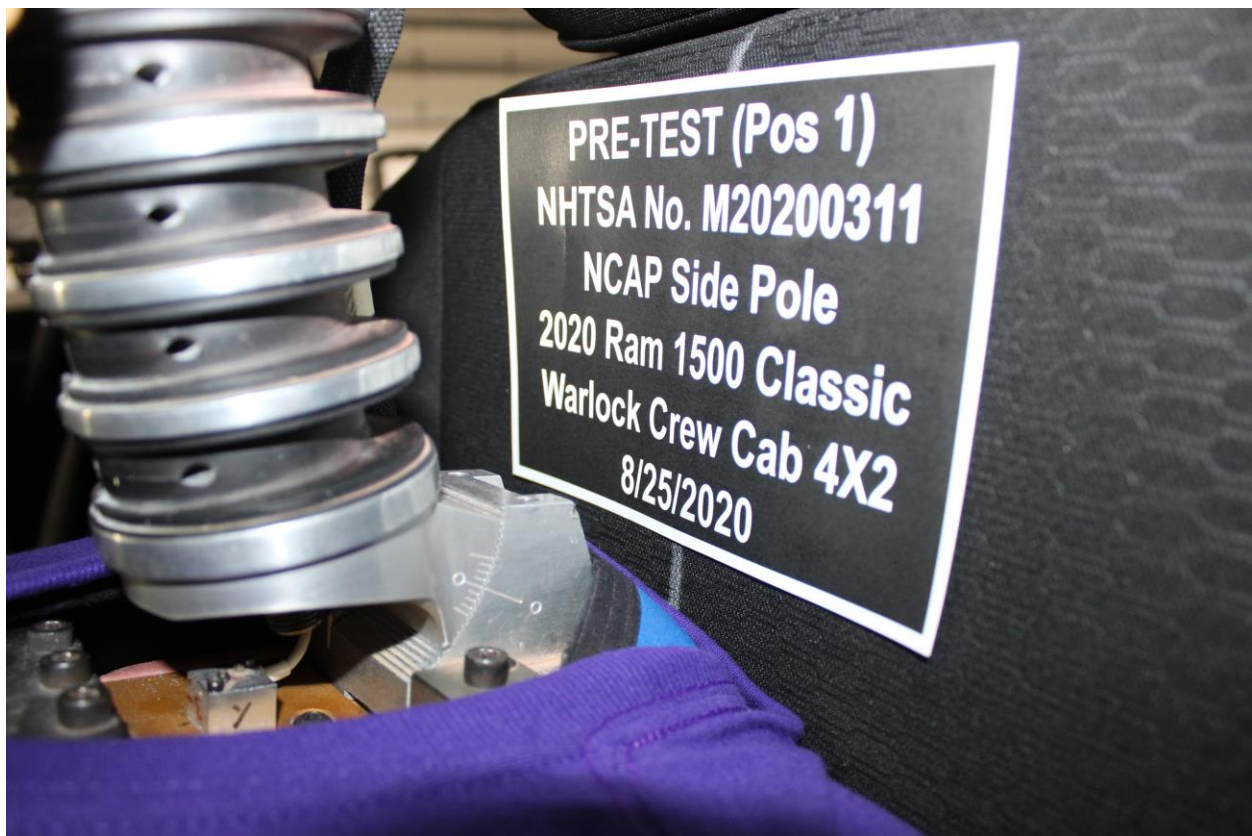

Figure A-30: Pre-Test Left Side View of Dummy's Neck Showing Position of Adjustable Neck Bracket

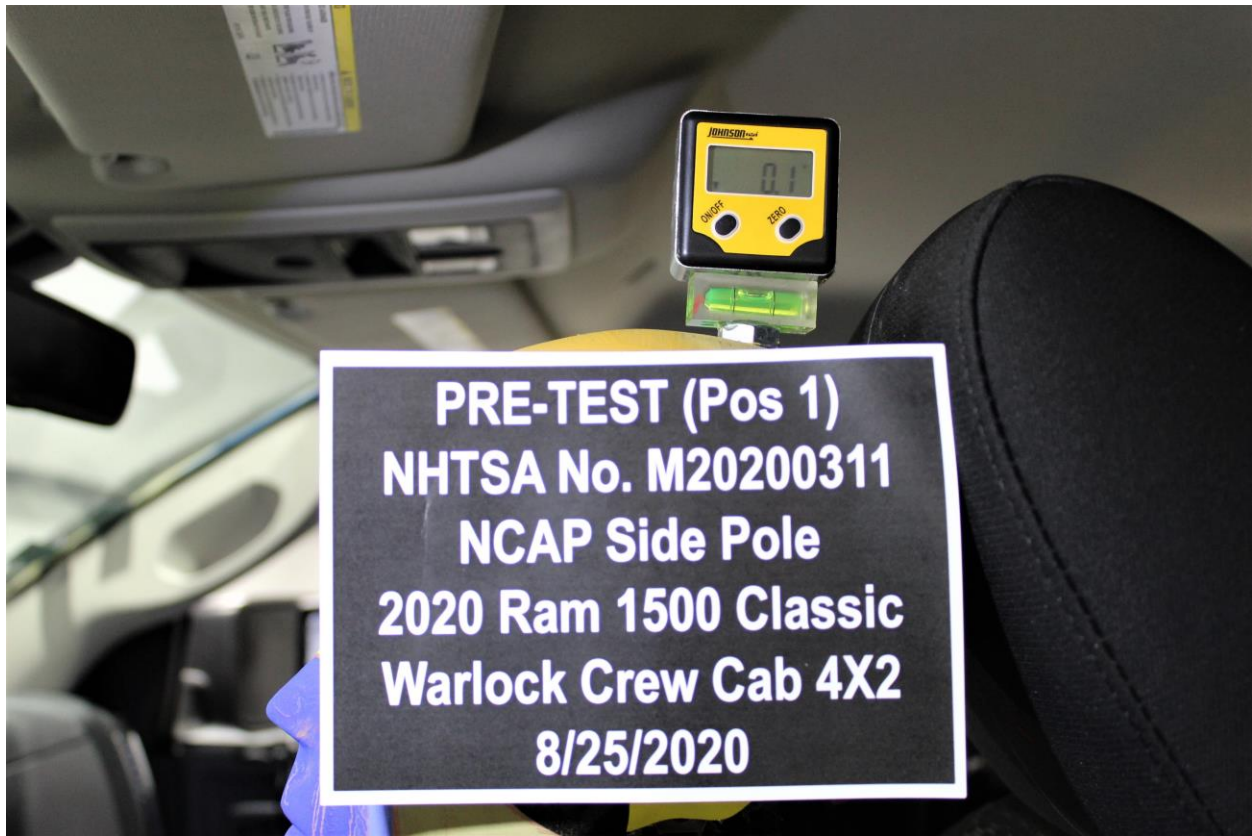

Figure A-31: Pre-Test Left Side View of Dummy's Head Showing Dummy's Head is Level



Figure A-32: Pre-Test Placement of Dummy's Feet



Figure A-33: Pre-Test View of Belt Anchorage for Dummy

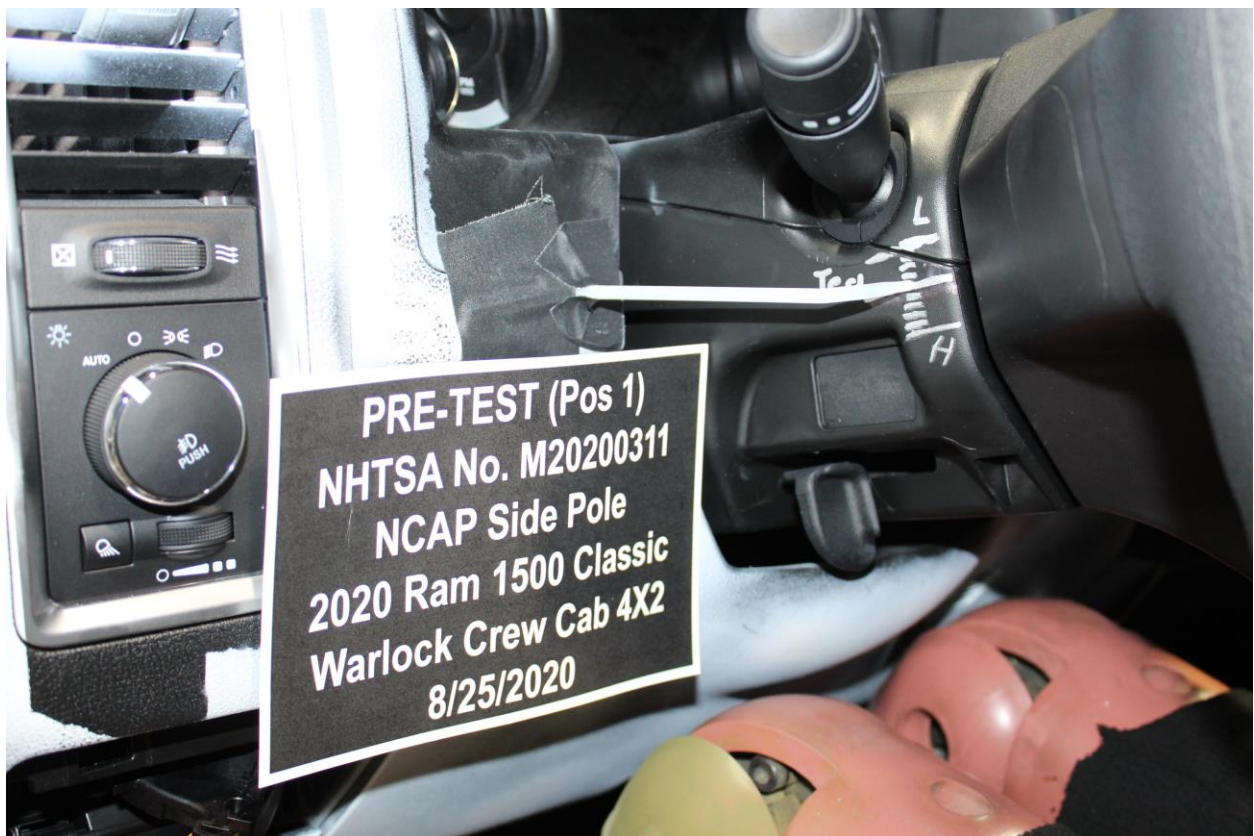

Figure A-34: Pre-Test Left Side View of Steering Wheel



Figure A-35: Pre-Test View of Disengaged Parking Brake

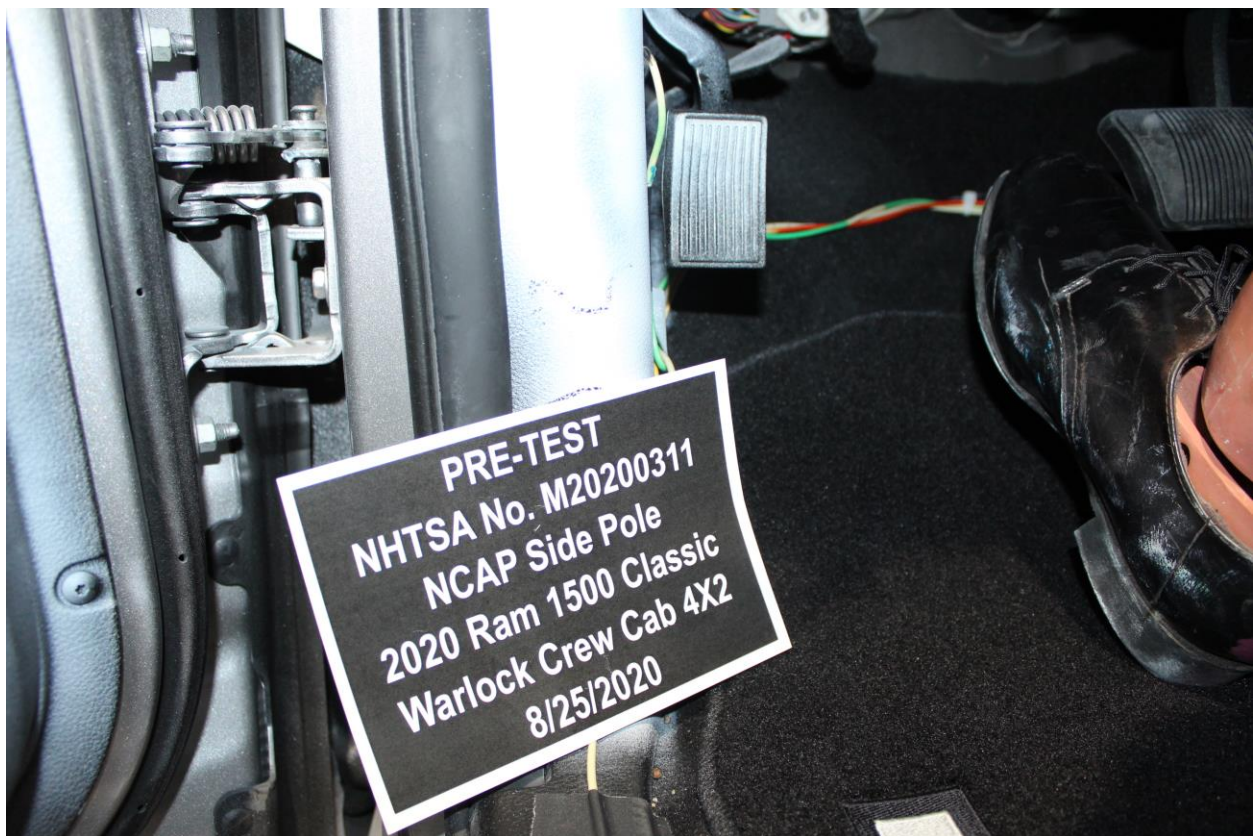

Figure A-36: Pre-Test View of Parking Brake



Figure A-37: Pre-Test Close-Up Left Side View of Driver Seat Track



Figure A-38: Pre-Test Close-Up Left Side View of Driver Seat Back



Figure A-39: Pre-Test Close-Up View of Driver Seat Back or Head Restraint



Figure A-40: Pre-Test Dummy and Door Clearance View



Figure A-41: Post-Test Dummy and Door Clearance View

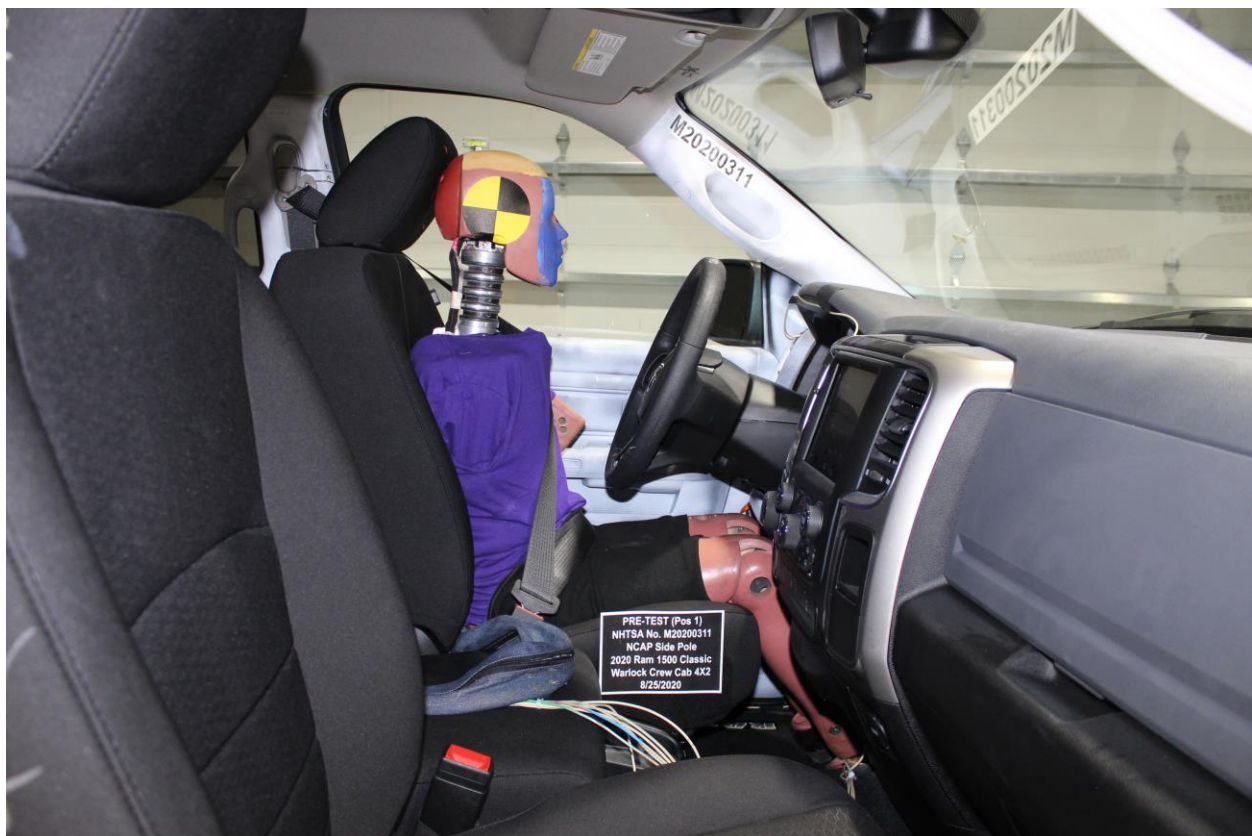

Figure A-42: Pre-Test Right Side View of Dummy and Front Seat of Occupant Compartment



Figure A-43: Post-Test Right Side View of Dummy and Front Seat of Occupant Compartment

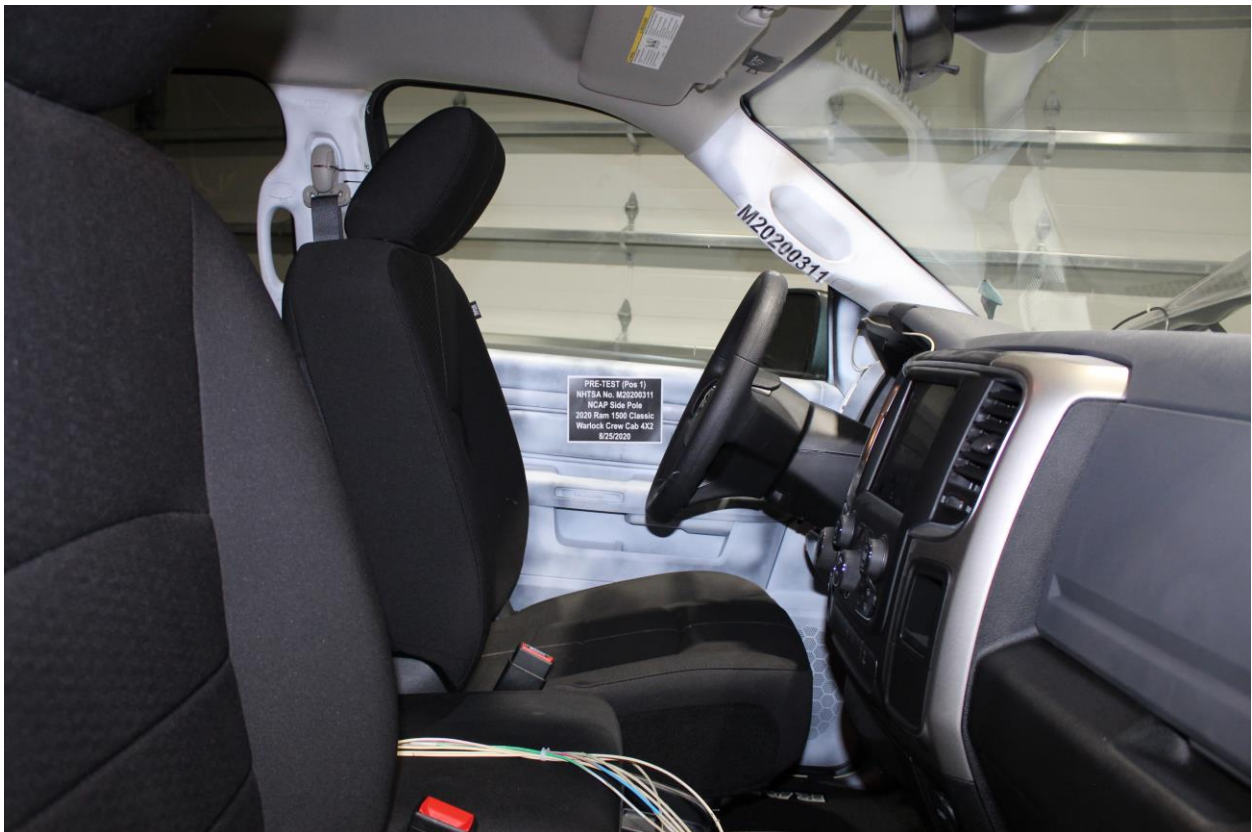

Figure A-44: Pre-Test Inner Door Panel View



Figure A-45: Post-Test Inner Door Panel View Showing Dummy Contact Location



Figure A-46: Post-Test Dummy Close-Up Head Contact with Vehicle Interior View

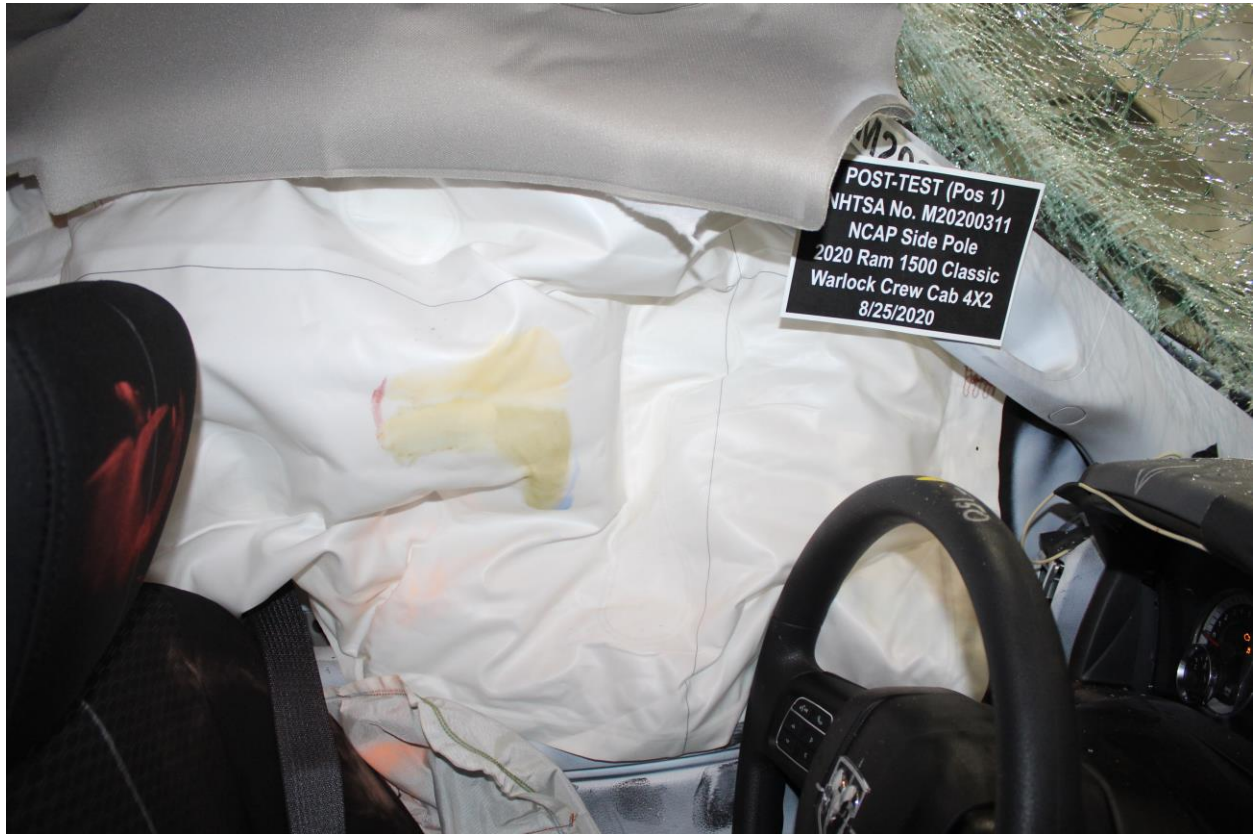

Figure A-47: Post-Test Dummy Close-Up Head Contact with Side Airbag View



Figure A-48: Post-Test Dummy Close-Up Torso Contact with Vehicle Interior View



Figure A-49: Post-Test Dummy Close-Up Torso Contact with Side Airbag View



Figure A-50: Post-Test Dummy Close-Up Pelvis Contact with Vehicle Interior View



Figure A-51: Post-Test Dummy Close-Up Pelvis Contact with Side Airbag View

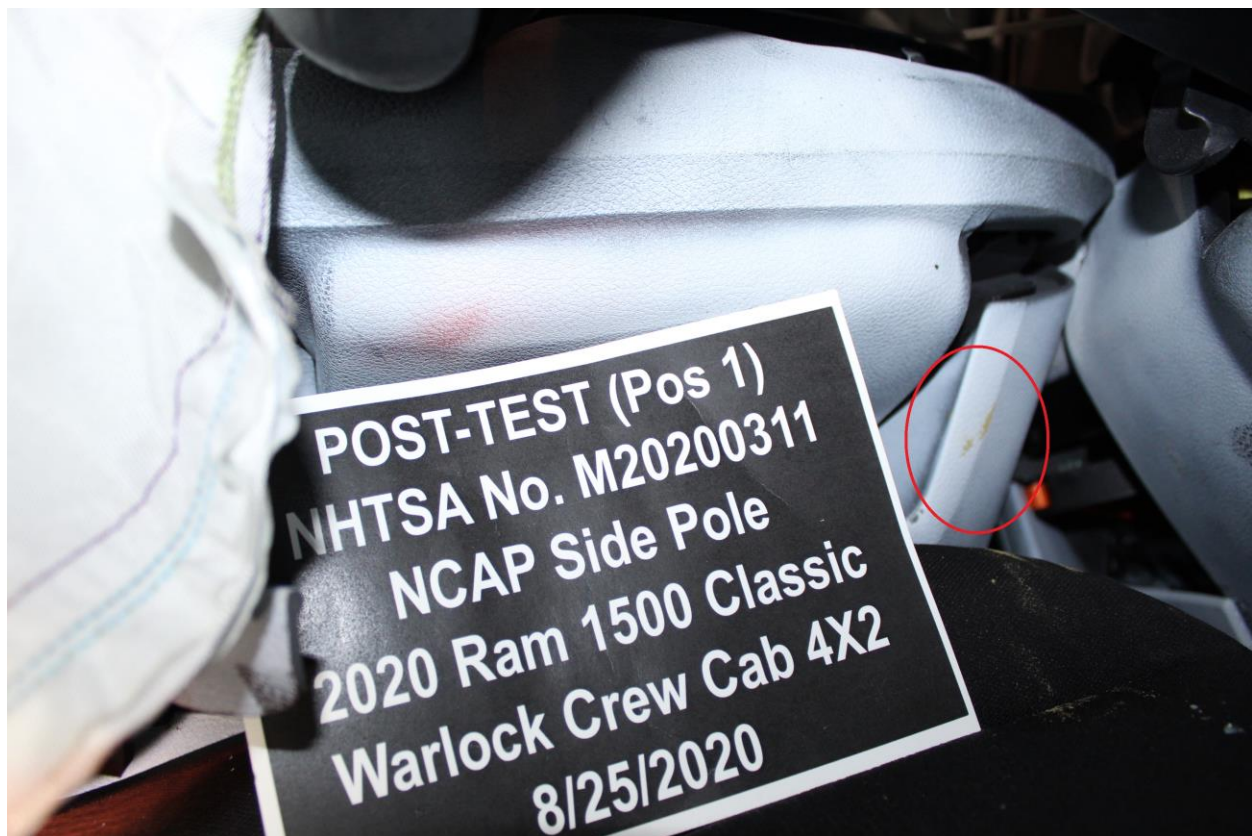

Figure A-52: Post-Test Dummy Close-Up Knee Contact with Vehicle Interior View



Figure A-53: Pre-Test View of Fuel Filler Cap or Fuel Filler Neck



Figure A-54: Post-Test View of Fuel Filler Cap or Fuel Filler Neck



Figure A-55: Close-Up View of Vehicle's Certification Label

Photo Not Applicable

Figure A-55a: Close-Up View of Reduced Load Capacity Label

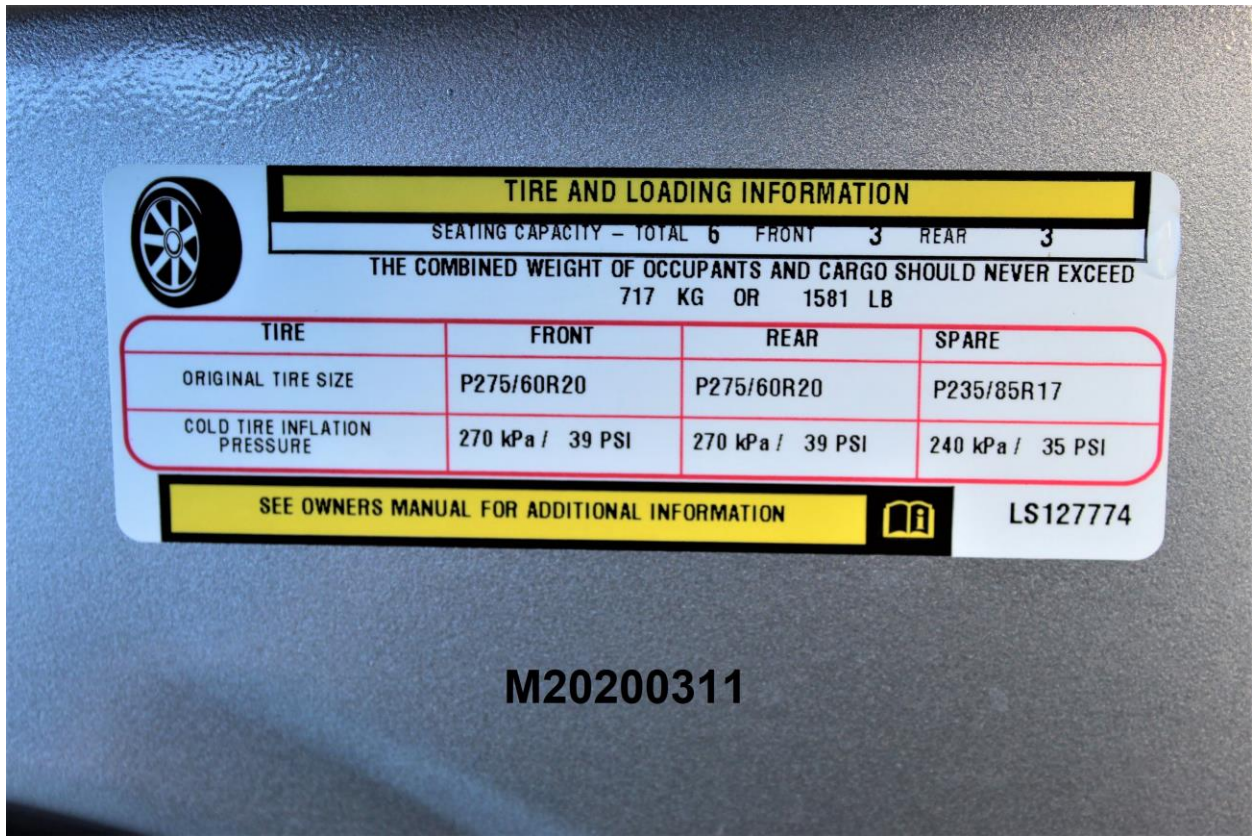

Figure A-56: Close-Up View of Vehicle's Tire Information Placard or Label

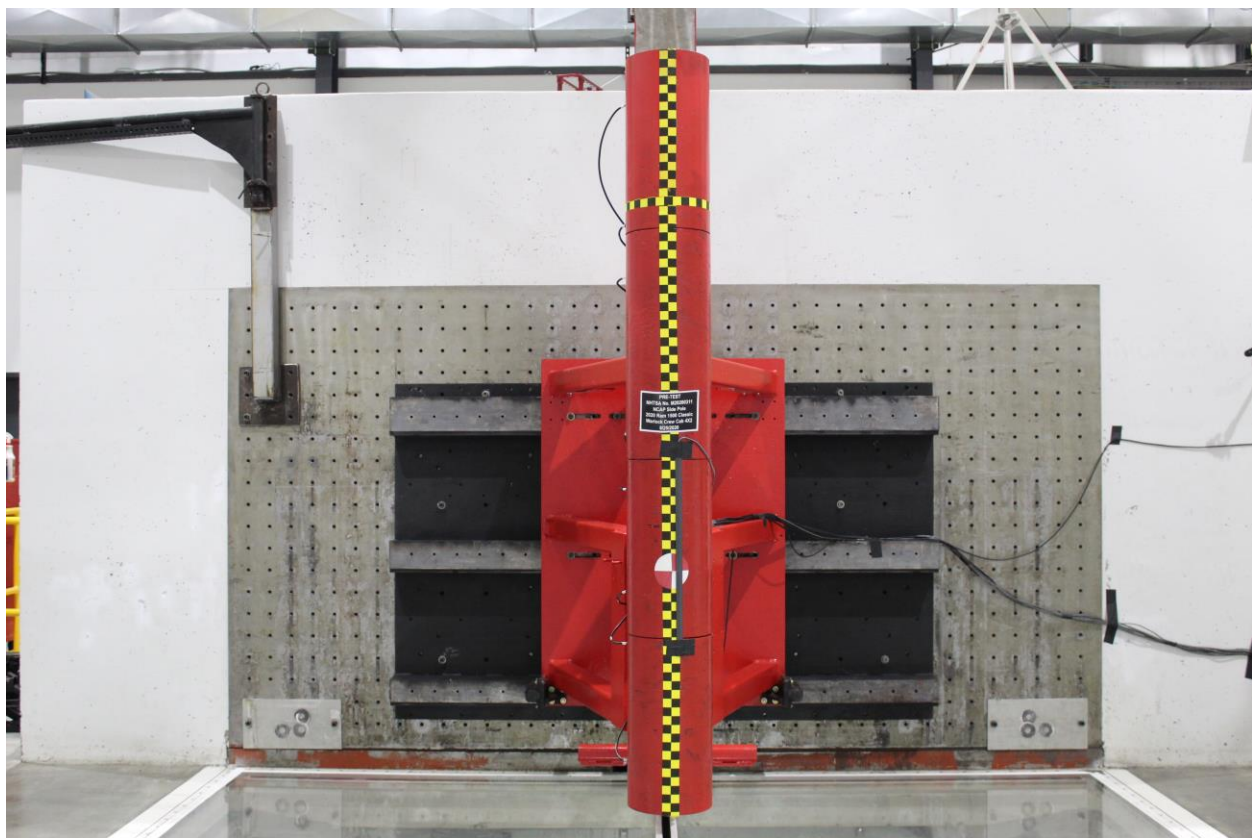

Figure A-57: Pre-Test Pole Barrier Front View

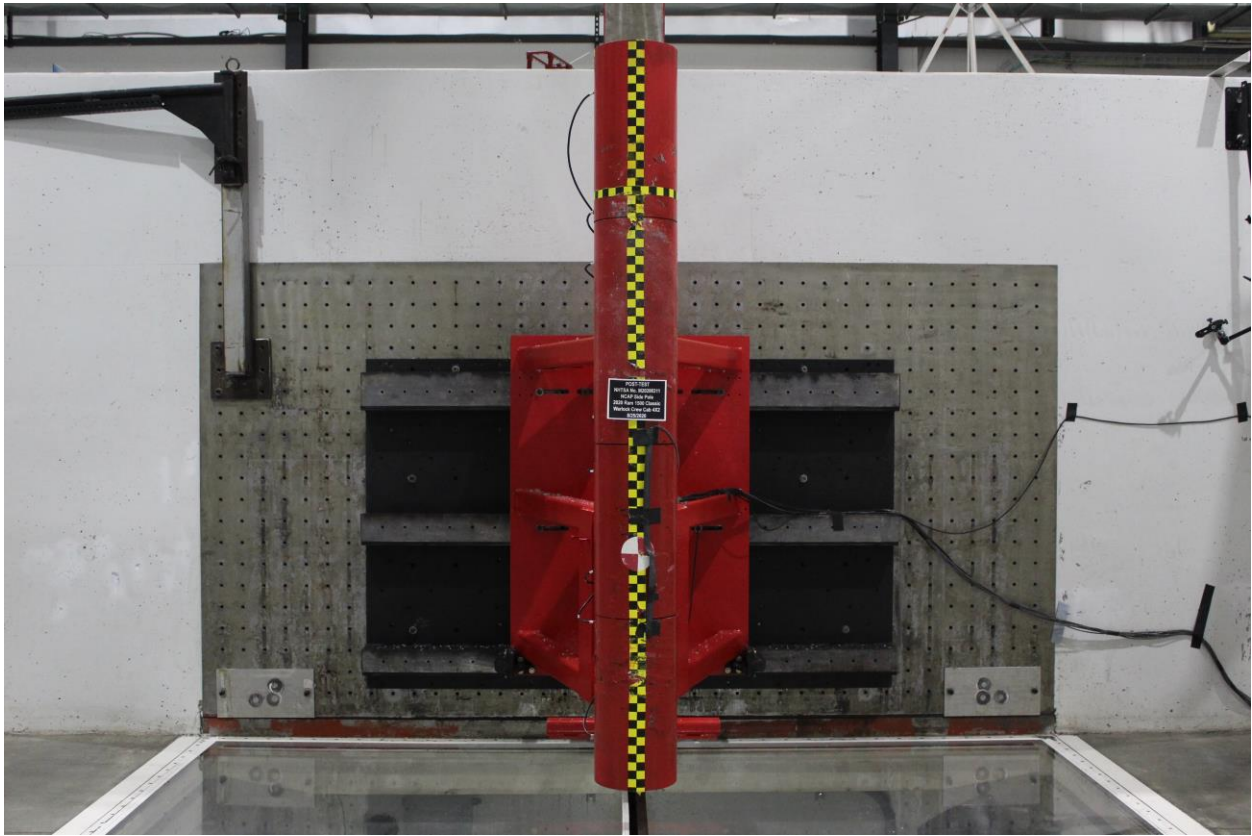

Figure A-58: Post-Test Pole Barrier Front View

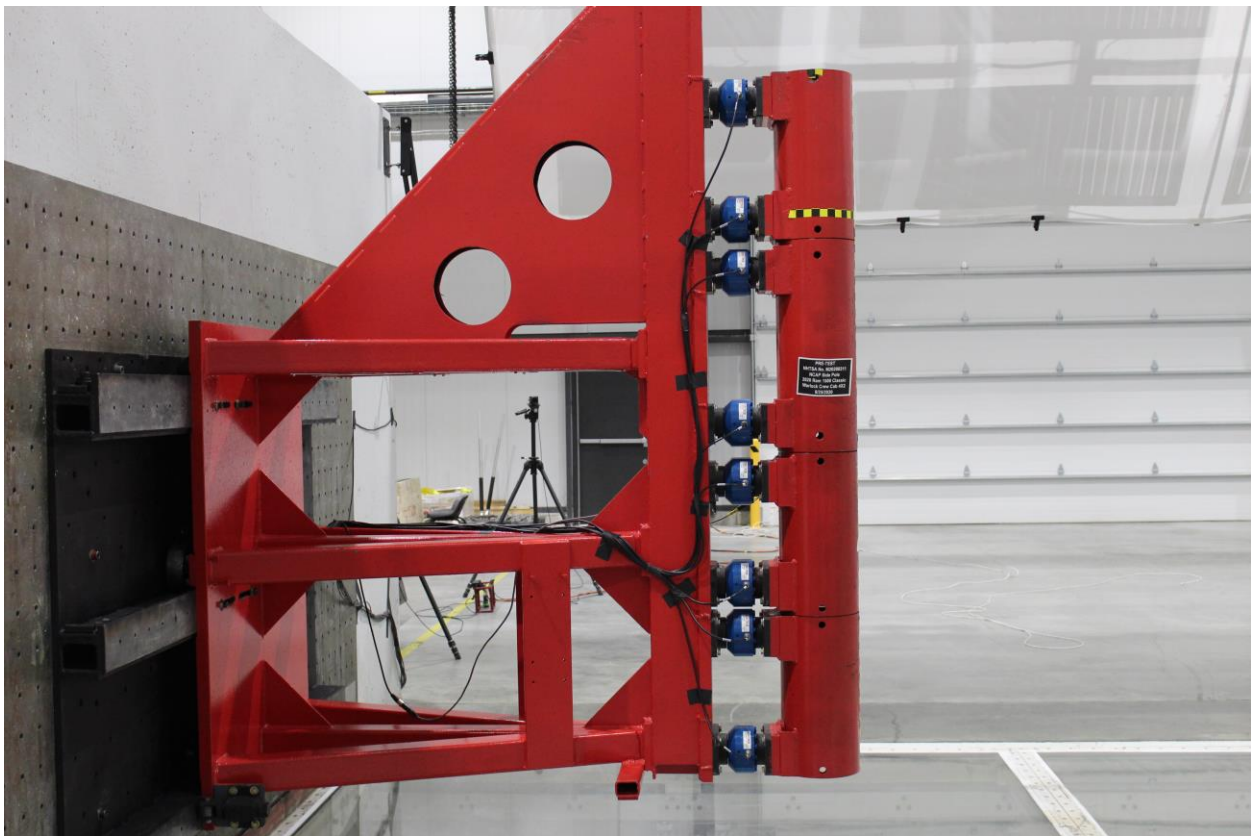

Figure A-59: Pre-Test Pole Barrier Side View

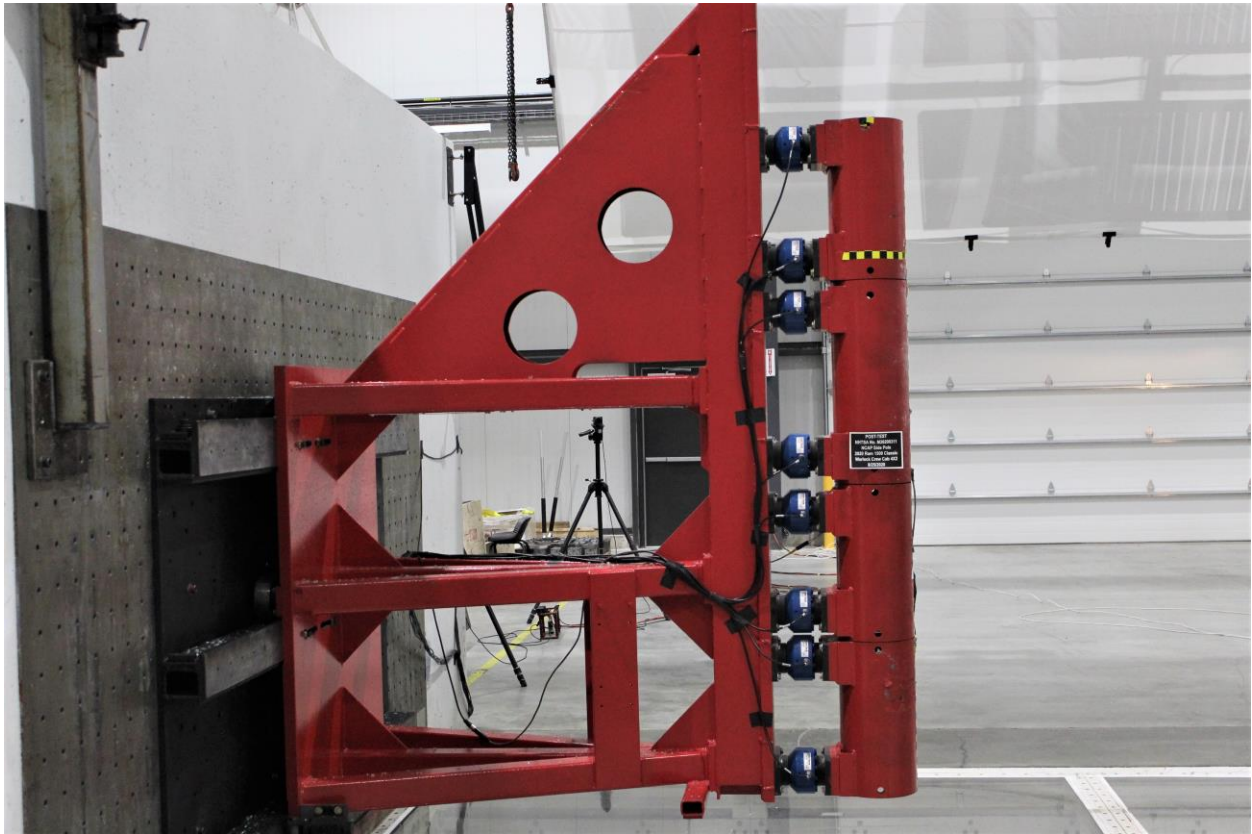

Figure A-60: Post-Test Pole Barrier Side View

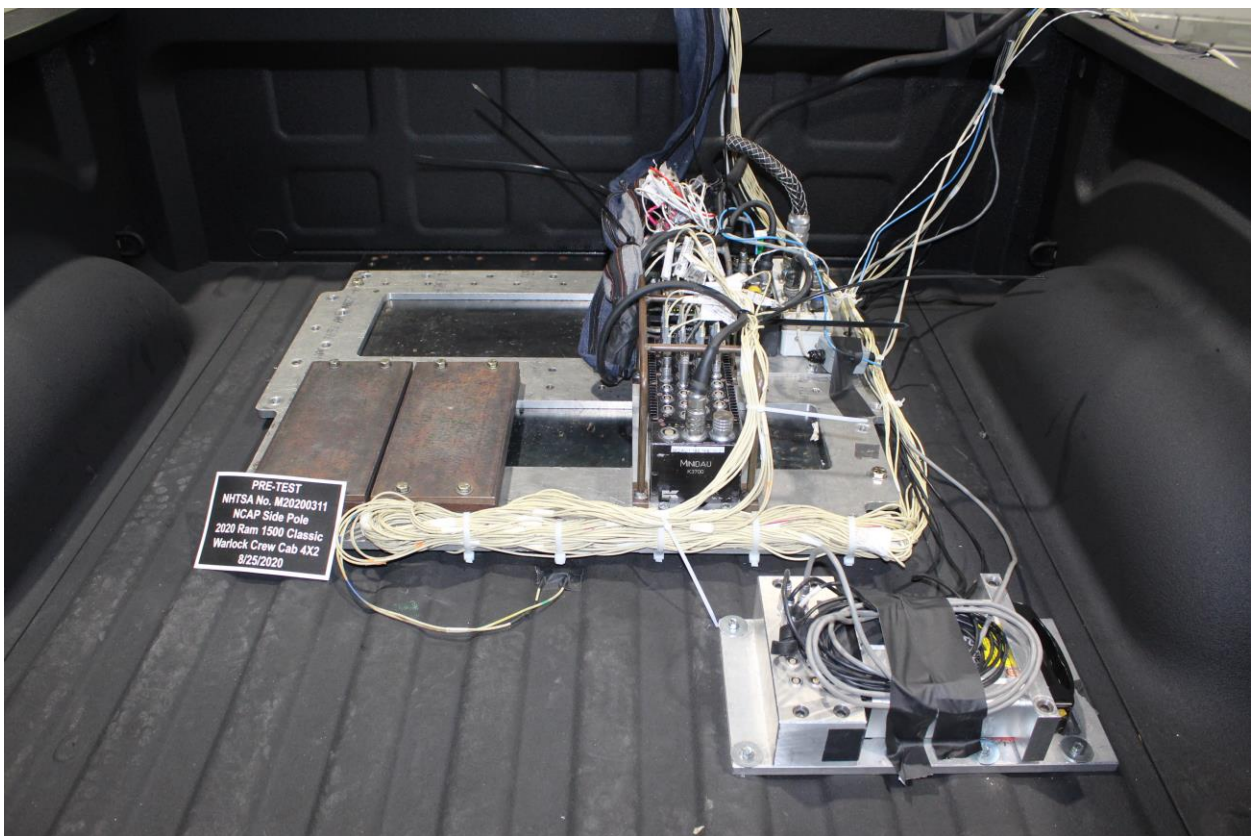

Figure A-61: Pre-Test Ballast View



Figure A-62: Post-Test Primary and Redundant Speed Trap Read-Out

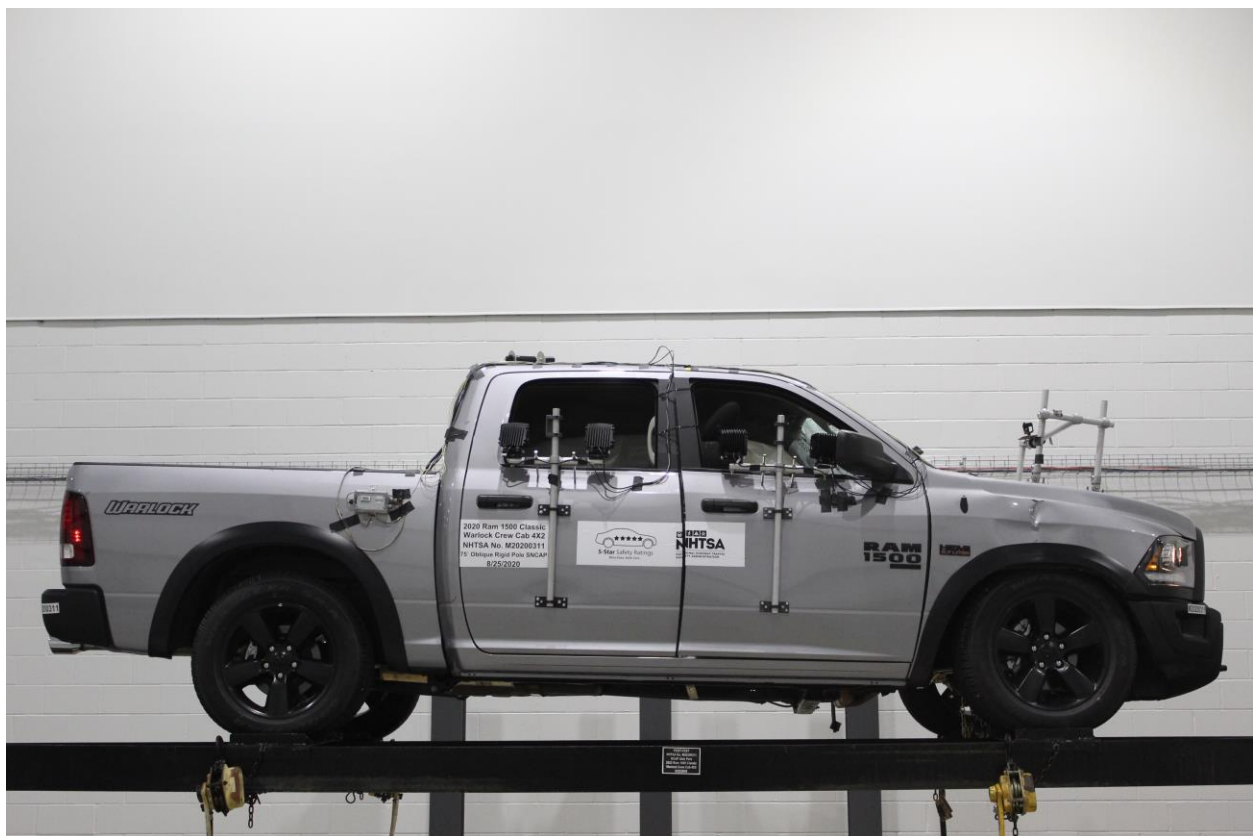

Figure A-63: FMVSS No. 301 Static Rollover 0 Degrees

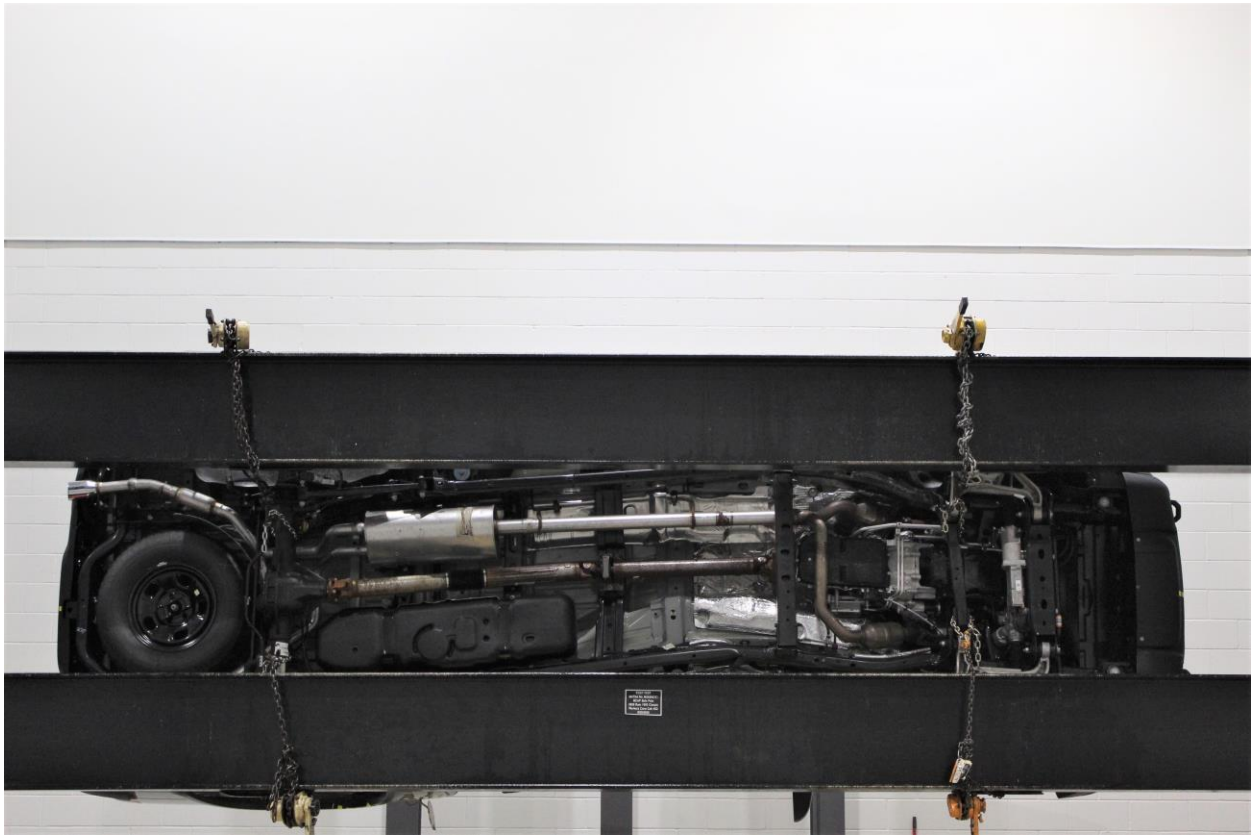

Figure A-64: FMVSS No. 301 Static Rollover 90 Degrees



Figure A-65: FMVSS No. 301 Static Rollover 180 Degrees



Figure A-66: FMVSS No. 301 Static Rollover 270 Degrees



Figure A-67: FMVSS No. 301 Static Rollover 360 Degrees

Vehicles Equipped With Remote Start

On models that are equipped with remote start, the ventilated seats can be programmed to come on during a remote start.

If your vehicle is equipped with a touchscreen, this feature can be programmed through the Uconnect system. Refer to "Uconnect Settings" in "Multimedia" for further information.

If your vehicle is not equipped with a touchscreen, this feature can be programmed through the instrument cluster display. Refer to "Instrument Cluster Display" in "Getting To Know Your Instrument Panel" for further information.

Plastic Grocery Bag Retainers (Regular Cab Models)

Retainer hooks which will hold plastic grocery bag handles are built into the back panel of the cab, behind the rear seat.

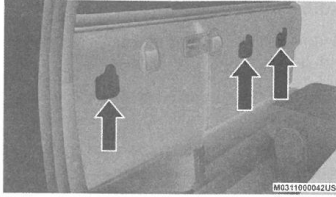

Grocery Bag Hooks

HEAD RESTRAINTS

Head restraints are designed to reduce the risk of injury by restricting head movement in the event of a rear impact. Head restraints should be adjusted so that the top of the head restraint is located above the top of your ear.

WARNING!

- All occupants, including the driver, should not operate a vehicle or sit in a vehicle's seat until the head restraints are placed in their proper positions in order to minimize the risk of neck injury in the event of a crash.

(Continued)

WARNING! (Continued)

- Head restraints should never be adjusted while the vehicle is in motion. Driving a vehicle with the head restraints improperly adjusted or removed could cause serious injury or death in the event of a collision.

Front Head Restraint Adjustment

To raise the head restraint, pull upward on the head restraint. To lower the head restraint, push the adjustment button located on the base of the head restraint and push downward on the head restraint.

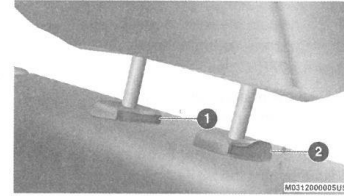

Adjustment Buttons

- 1 — Release Button
- 2 — Adjustment Button

Figure A-70: Head Restraint Use and Adjustment Information from Vehicle Owner's Manual



Figure A-71: Post-Test View of Shattered Vehicle Inner Door Panel (if applicable)

APPENDIX B

VEHICLE AND DUMMY RESPONSE DATA PLOTS

TABLE OF DATA PLOTS
Driver Dummy Instrumentation Plots

Fig.	Description	Page
1	Driver Head Acceleration (X) Primary vs. Time	B-4
2	Driver Head Acceleration (Y) Primary vs. Time	B-4
3	Driver Head Acceleration (Z) Primary vs. Time	B-4
4	Driver Head Resultant Acceleration Primary vs. Time	B-4
5	Driver Lower Spine T12 Acceleration (X) vs. Time	B-5
6	Driver Lower Spine T12 Acceleration (Y) vs. Time	B-5
7	Driver Lower Spine T12 Acceleration (Z) vs. Time	B-5
8	Driver Lower Spine T12 Resultant Acceleration vs. Time	B-5
9	Driver Iliac Wing Force on Impact Side (Y) vs. Time	B-6
10	Driver Acetabulum Force on Impact Side (Y) vs. Time	B-6
11	Driver Total Pelvis Force on Impact Side (Y) vs. Time	B-6

The following additional data for this test can be obtained from the Research and Development section of the NHTSA website. The website can be found at www.NHTSA.gov.

Additional Driver Dummy Instrumentation Data

Driver Head Acceleration Redundant (X)
Driver Head Acceleration Redundant (Y)
Driver Head Acceleration Redundant (Z)
Driver Upper Thorax Rib Deflection (Y)
Driver Middle Thorax Rib Deflection (Y)
Driver Lower Thorax Rib Deflection (Y)
Driver Upper Abdomen Rib Deflection (Y)
Driver Lower Abdomen Rib Deflection (Y)

Vehicle Instrumentation Data

Vehicle Center of Gravity Acceleration (X)
Vehicle Center of Gravity Acceleration (Y)
Vehicle Center of Gravity Acceleration (Z)
Left Floor Sill Acceleration (Y)
Left A-Pillar Sill Acceleration (Y)
Left Lower A-Pillar Acceleration (Y)
Left Mid A-Pillar Acceleration (Y)
Left B-Pillar Sill Acceleration (Y)
Left Lower B-Pillar Acceleration (Y)
Left Mid B-Pillar Acceleration (Y)
Driver Seat Track at Dummy Hip Point Acceleration (Y)
Engine Top Acceleration (X)
Engine Top Acceleration (Y)
Firewall Center Acceleration (Y)
Right Roof at Vertical Impact Reference Line Acceleration (Y)
Right Sill at Vertical Impact Reference Line Acceleration (Y)
Rear Floorpan Behind Rear Axle at Centerline Acceleration (X)
Rear Floorpan Behind Rear Axle at Centerline Acceleration (Y)

Pole Instrumentation Data

Load Cell Pole Barrier #1 Force (Y)
Load Cell Pole Barrier #2 Force (Y)
Load Cell Pole Barrier #3 Force (Y)
Load Cell Pole Barrier #4 Force (Y)
Load Cell Pole Barrier #5 Force (Y)
Load Cell Pole Barrier #6 Force (Y)
Load Cell Pole Barrier #7 Force (Y)
Load Cell Pole Barrier #8 Force (Y)

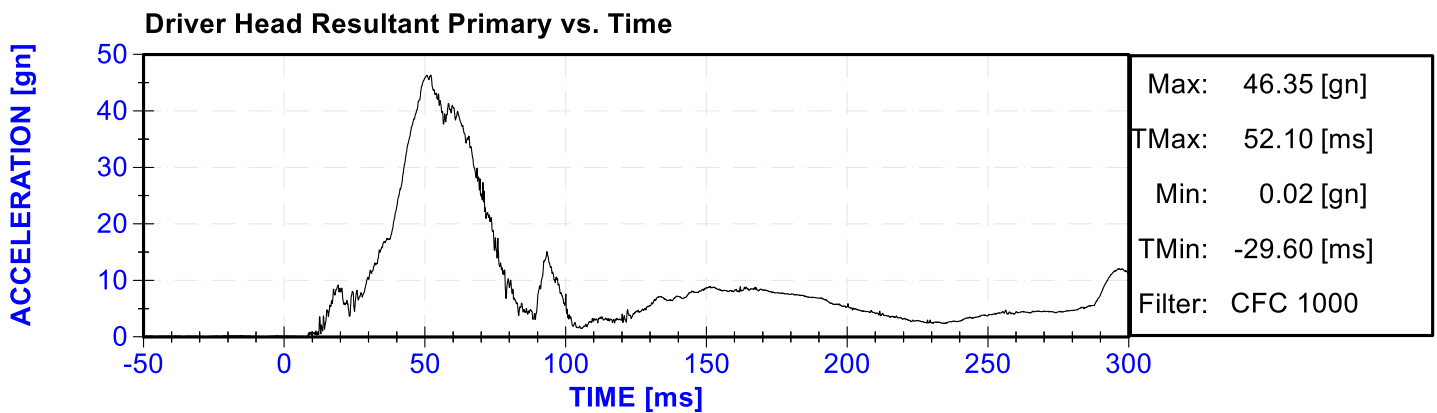
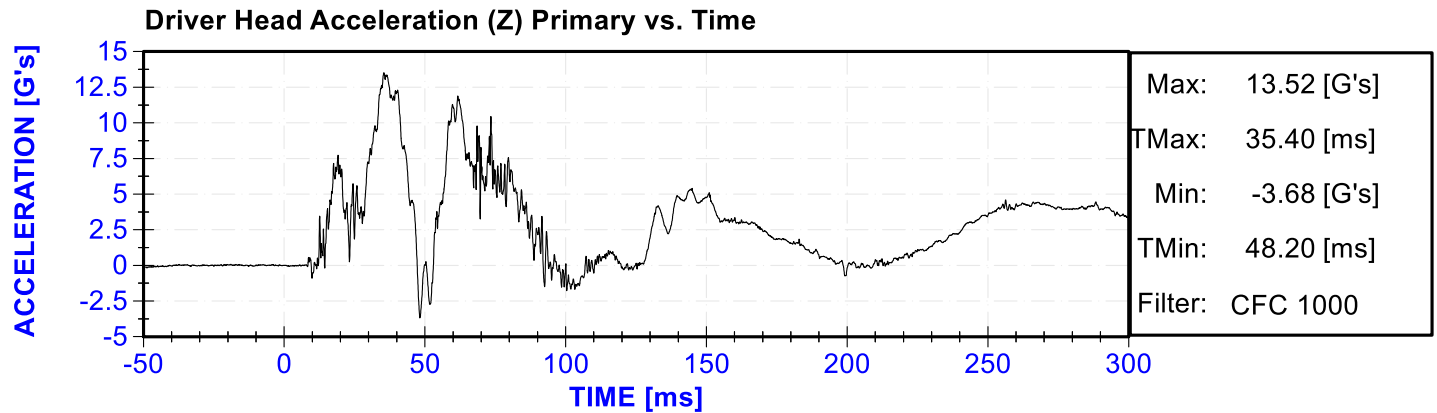
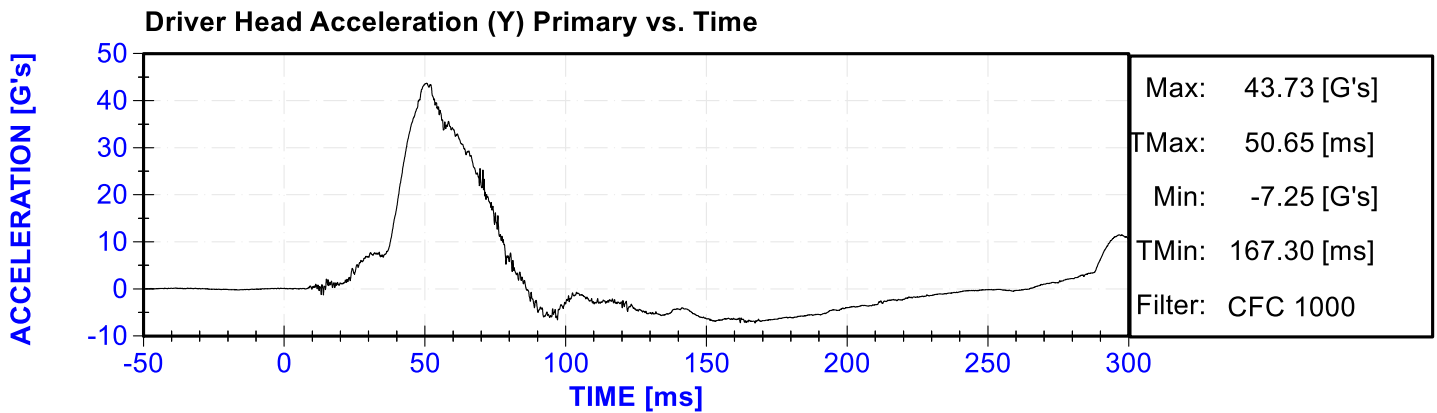
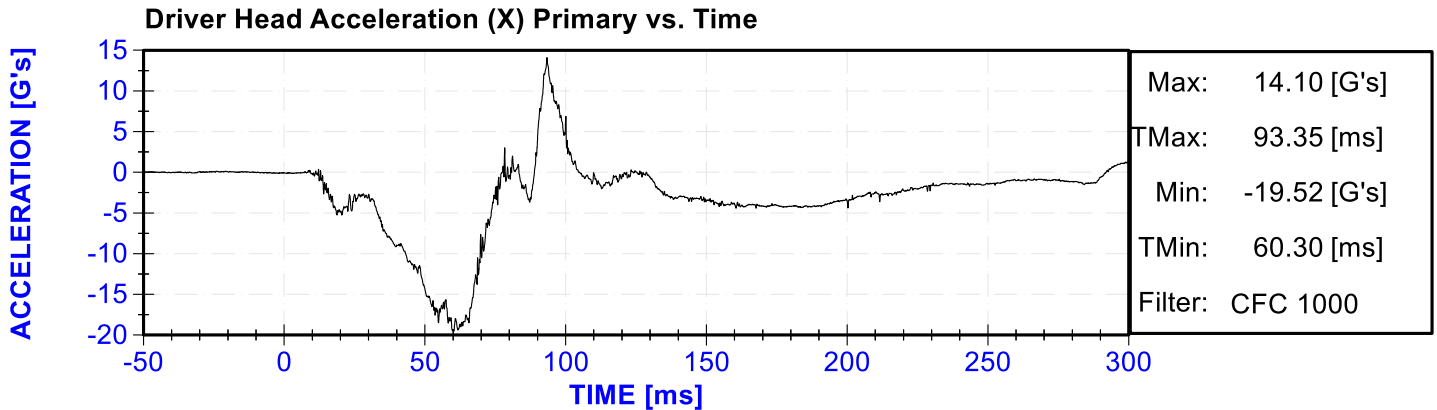

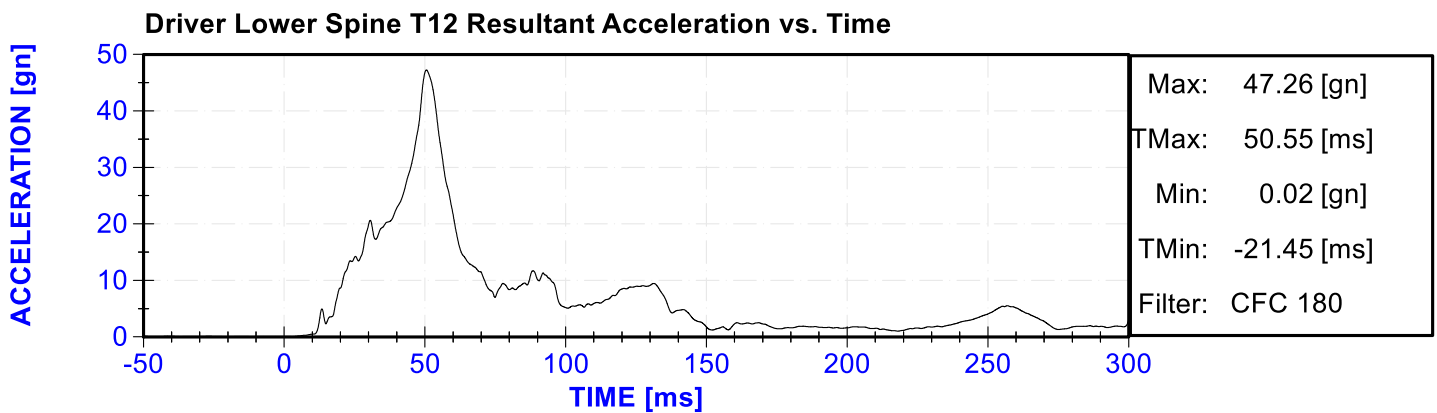
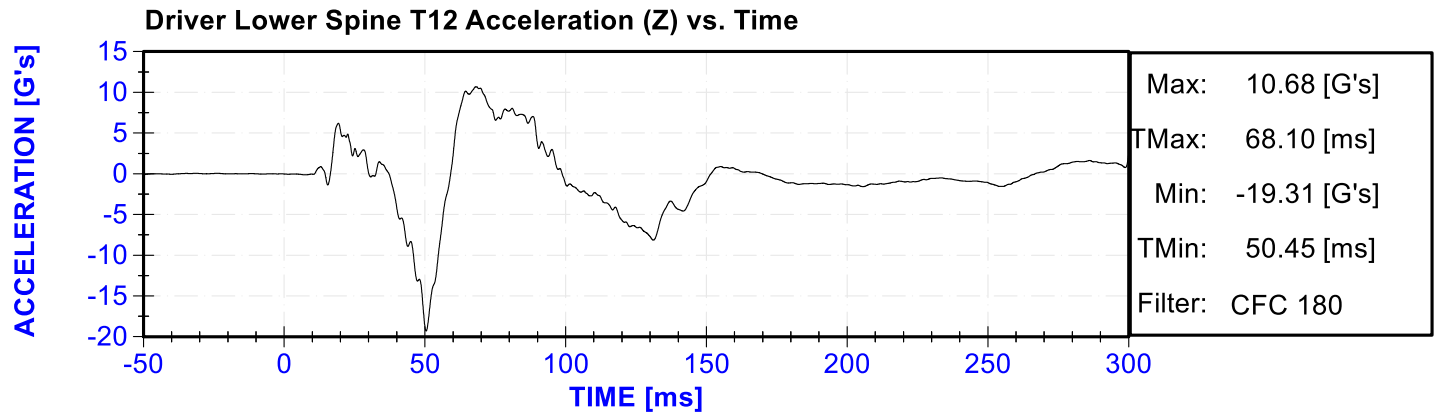
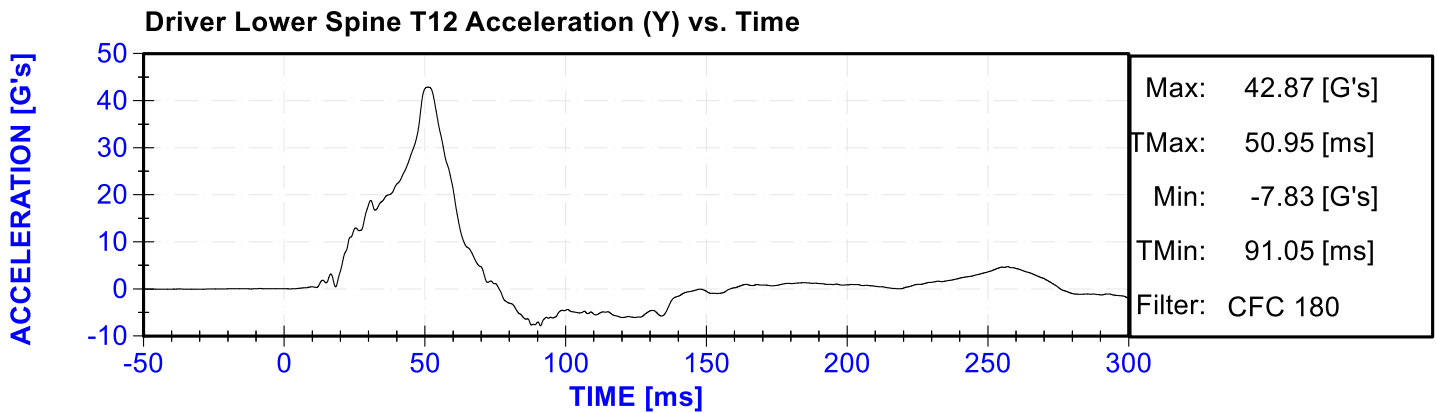
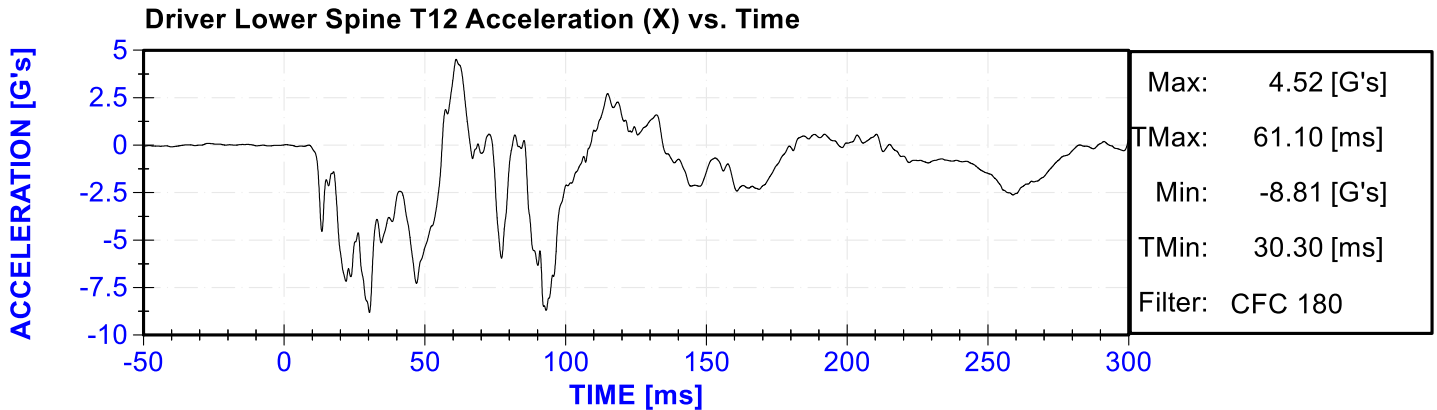

Driver Iliac Wing Force on Impact Side (Y) vs. Time

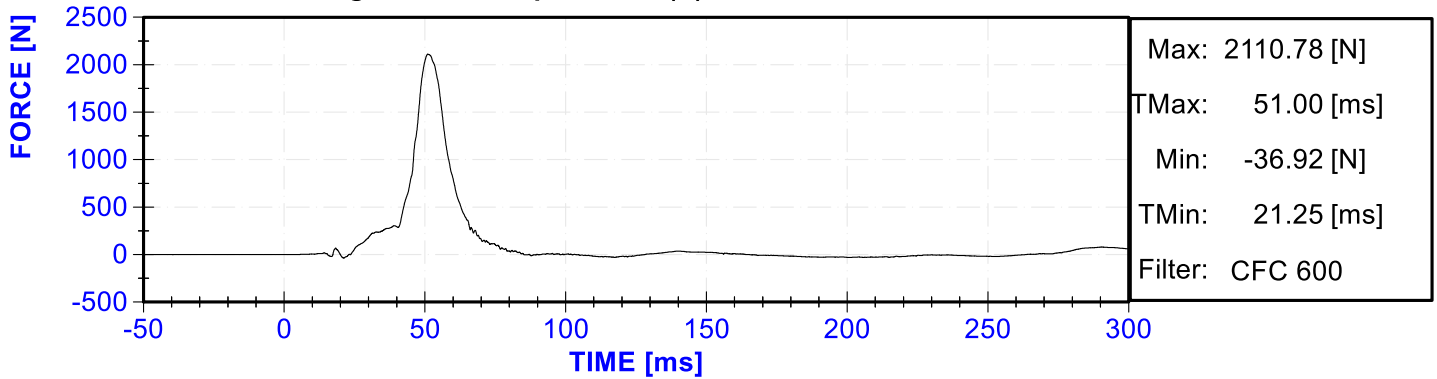

Driver Acetabulum Force on Impact Side (Y) vs. Time

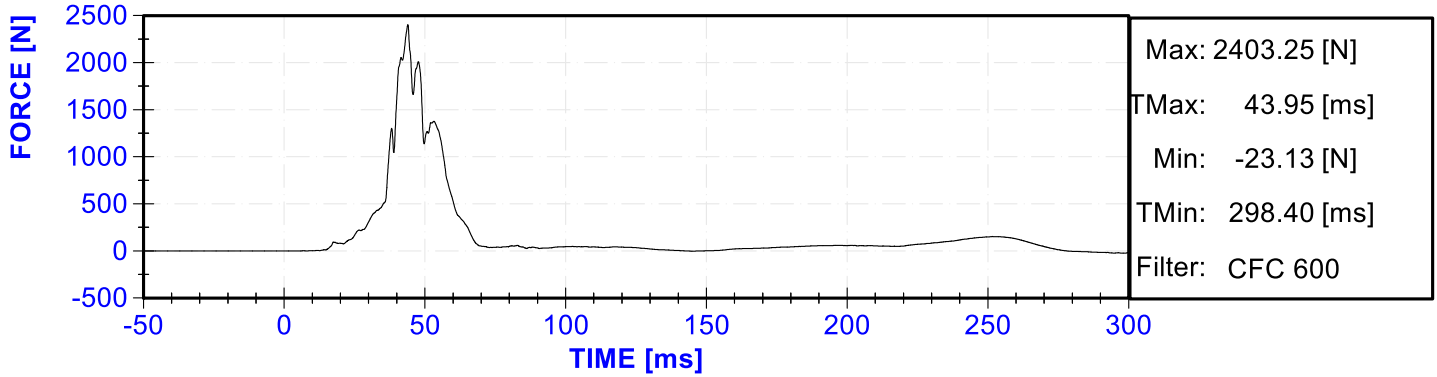

Driver Total Pelvis Force on Impact Side (Y) vs. Time

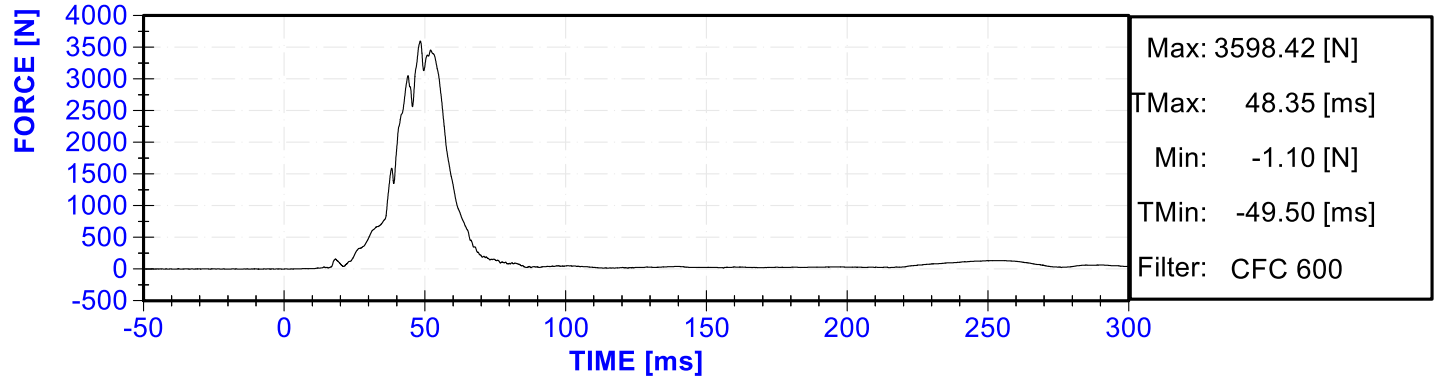

APPENDIX C

DUMMY CONFIGURATION AND PERFORMANCE VERIFICATION DATA

CALIBRATION TEST RESULTS

PRE-TEST

SID-IIS 5TH PERCENTILE FEMALE - DRIVER ATD

SERIAL NO: DG8012

(CONFIGURED FOR LEFT SIDE IMPACT)



External Measurements - SID-IIs

Technician: K. Dutton

Date: 08/14/2020

Dummy Serial Number: DG8012

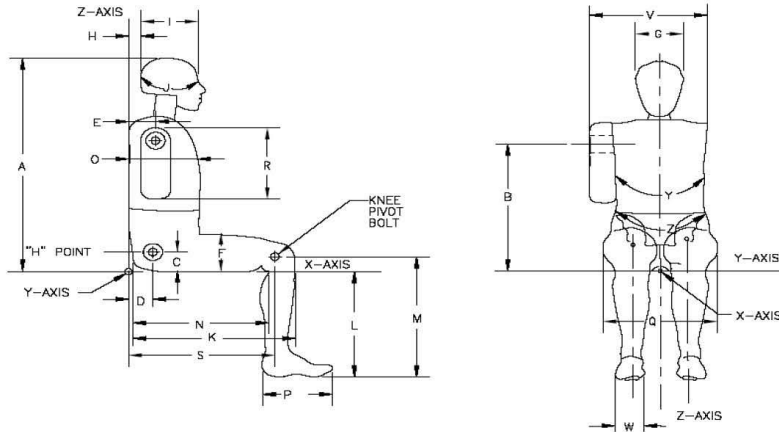

Symbol	Description	Specification (mm)		Result (mm)	Pass/Fail
A	Sitting Height	772	788	779	Pass
B	Shoulder Pivot Height	437	453	446	Pass
C	H-point Height	79	89	84	Pass
D	H-point from seatback	141	151	146	Pass
E	Shoulder Pivot from Backline	97	107	104	Pass
F	Thigh Clearance	119	135	127	Pass
G	Head Breadth	140	148	144	Pass
H	Head Back from Backline	40	46	44	Pass
I	Head Depth	178	188	184	Pass
J	Head Circumference	541	551	547	Pass
K	Buttock to Knee Length	514	540	533	Pass
L	Popliteal Height	343	369	357	Pass
M	Knee Pivot to floor height	392	409	402	Pass
N	Buttock Popliteal Length	416	442	433	Pass
O	Chest Depth w/o jacket	195	211	206	Pass
P	Foot Length	216	232	225	Pass
Q	Hip Breadth (w/pelvic plugs)	313	323	319	Pass
R	Arm Length	249	259	255	Pass
S	Knee Joint to seatback	477	493	486	Pass
V	Shoulder Width	341	357	346	Pass
W	Foot Width	78	94	85	Pass
Y	Chest Circumference w/jacket	851	881	867	Pass
Z	Waist Circumference	761	791	781	Pass

ATD Manufacturer	FTSS	Test Technician	K. Dutton
ATD Serial Number	DG8012	Laboratory Supervisor	K. Brogan

Results

Test Parameter	Minimum Specification	Maximum Specification	Unit	Result	Pass/Fail
Temperature	20.6	22.2	°C	20.9	Pass
Humidity	10	70	%	66	Pass
Resultant Acceleration	115	137	g's	127.3	Pass
Oscillation	0	15	%	1.1	Pass
Fore-Aft Acceleration	-15	15	g's	-2.5	Pass

Transducer Calibrations

Channel	Manufacturer	Serial Number	Calibration Date	Calibration Due Date
X Accelerometer	ENDEVCO 7264	AC-P74788	4/16/2020	10/15/2020
Y Accelerometer	ENDEVCO 7264CT	AC-P83432	4/16/2020	10/15/2020
Z Accelerometer	ENDEVCO 7264	AC-P83319	4/16/2020	10/15/2020

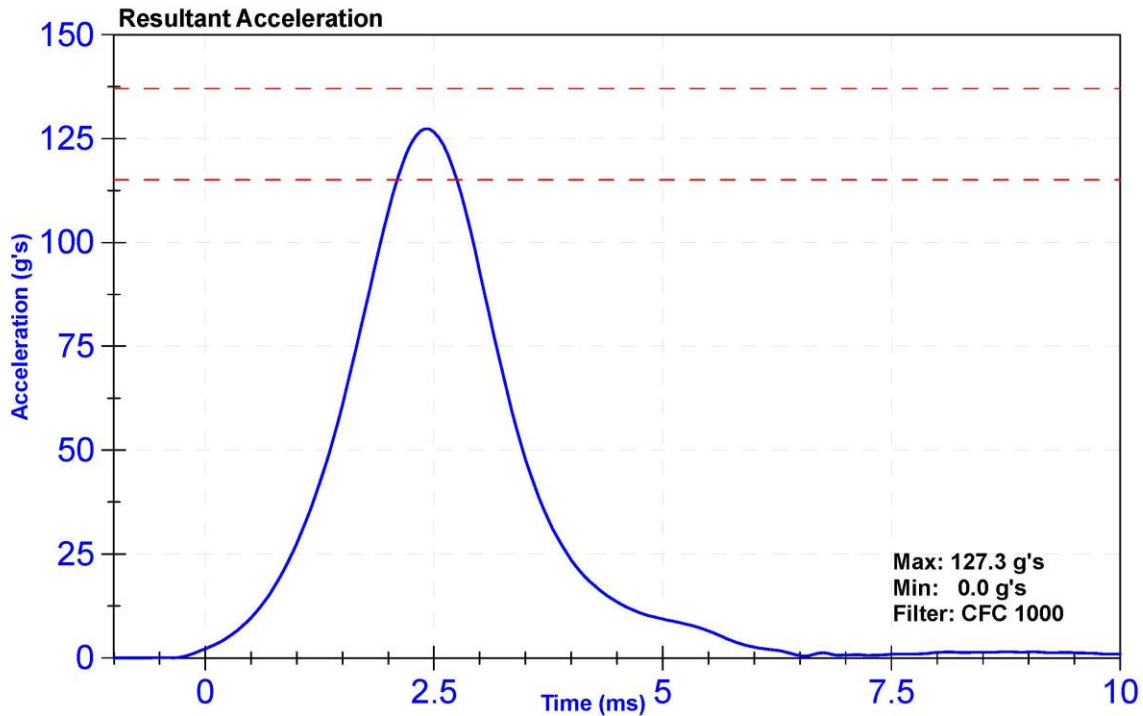

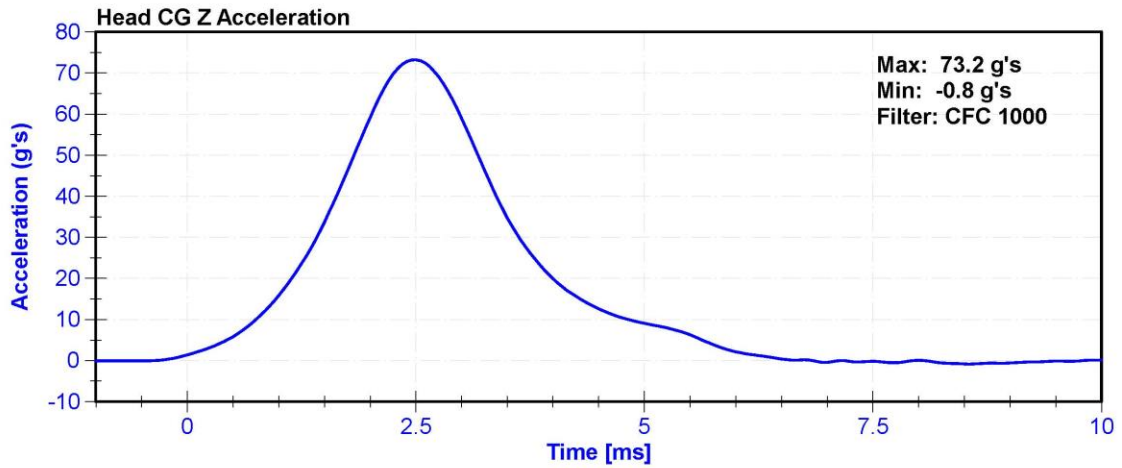
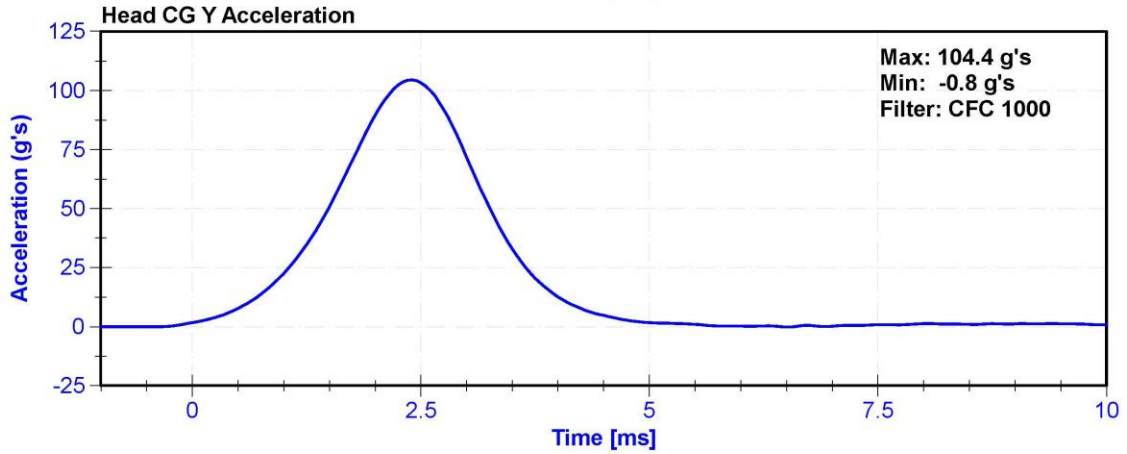
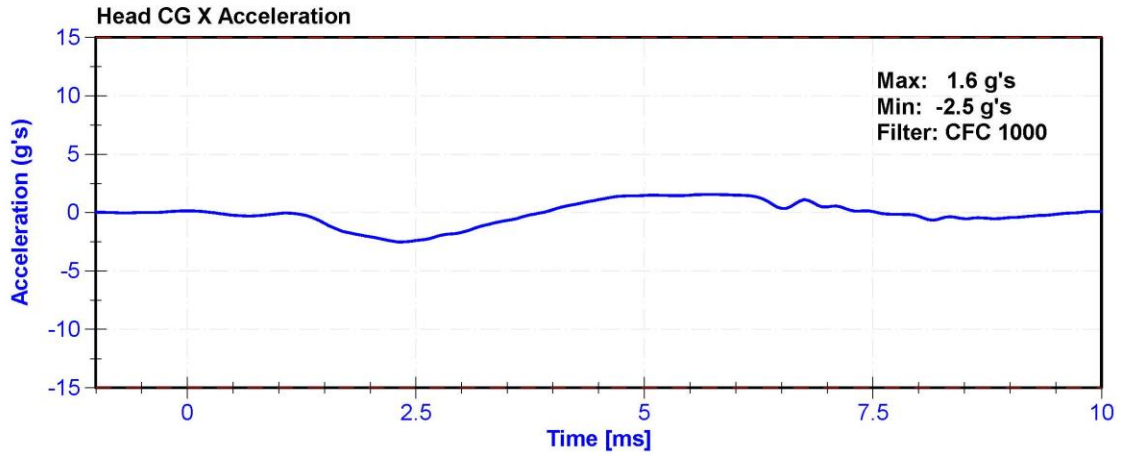

ATD Manufacturer	FTSS	Test Technician	K. Dutton
ATD Serial Number	DG8012	Laboratory Supervisor	K. Brogan

Results

Test Parameter	Minimum Specification	Maximum Specification	Unit	Result	Pass/Fail
Temperature	20.6	22.2	°C	21.3	Pass
Humidity	10	70	%	62.3	Pass
Velocity	5.51	5.63	m/s	5.584	Pass
Pendulum Impulse at 10ms	2.2	2.8	m/s	2.27	Pass
Pendulum Impulse at 15ms	3.3	4.1	m/s	3.42	Pass
Pendulum Impulse at 20ms	4.4	5.4	m/s	4.60	Pass
Pendulum Impulse at 25ms	5.4	6.1	m/s	5.54	Pass
Pendulum Impulse from 25 to 100ms	5.5	6.2	m/s	5.92	Pass
Neck Rotation	71	81	deg	74.0	Pass
Time at Maximum Rotation	50	70	ms	61.2	Pass
Moment about the OC	36	44	Nm	43.0	Pass
Moment Decay to 0 Nm	102	126	ms	115.2	Pass

Transducer Calibrations

Channel	Manufacturer	Serial Number	Calibration Date	Calibration Due Date
Pendulum Accelerometer	ENDEVCO 7231CT	AC-AH5M9 Pend	1/30/2020	1/29/2021
Pendulum Potentiometer	Denton 78051-342	DS-184Pend	11/4/2019	11/3/2020
Condyle Potentiometer	Denton 78051-342	DS-185Pend	11/4/2019	11/3/2020
Upper Neck Load Cell	Denton 1716	17162019 FY	3/18/2020	3/18/2021

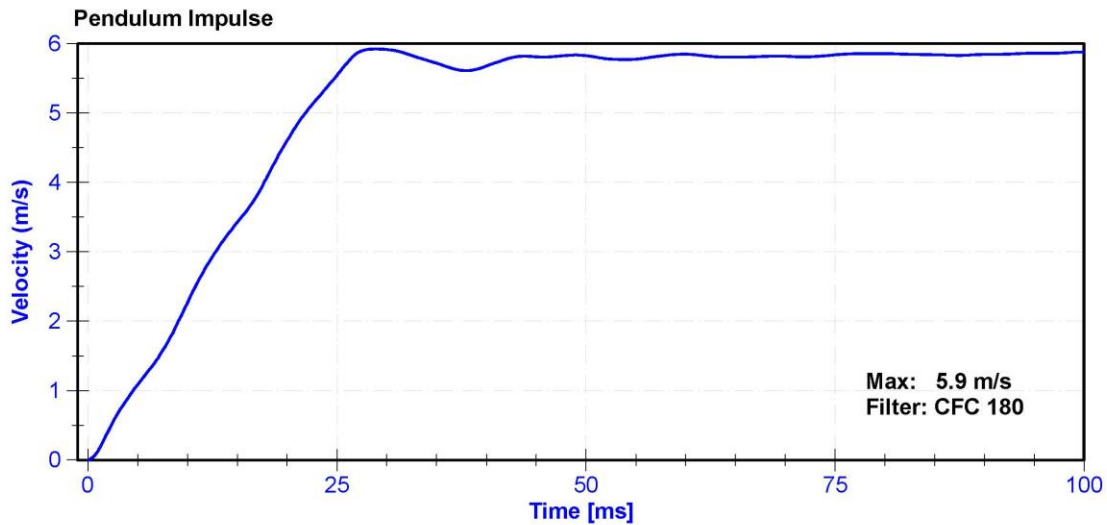

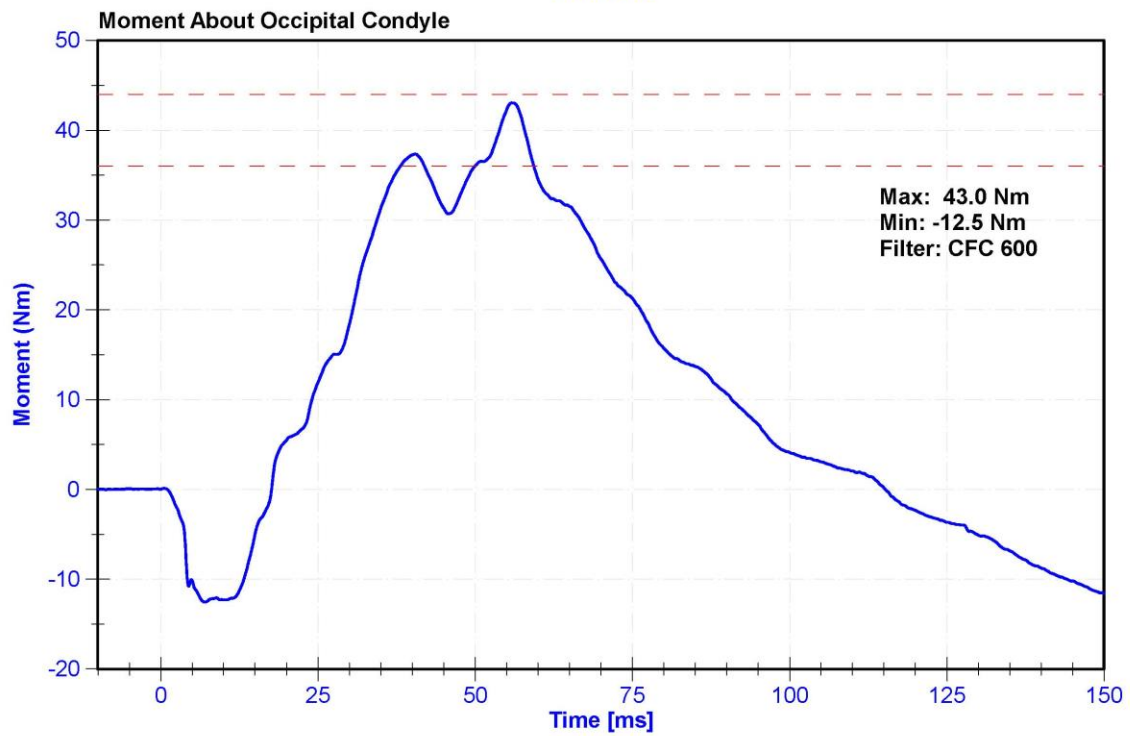
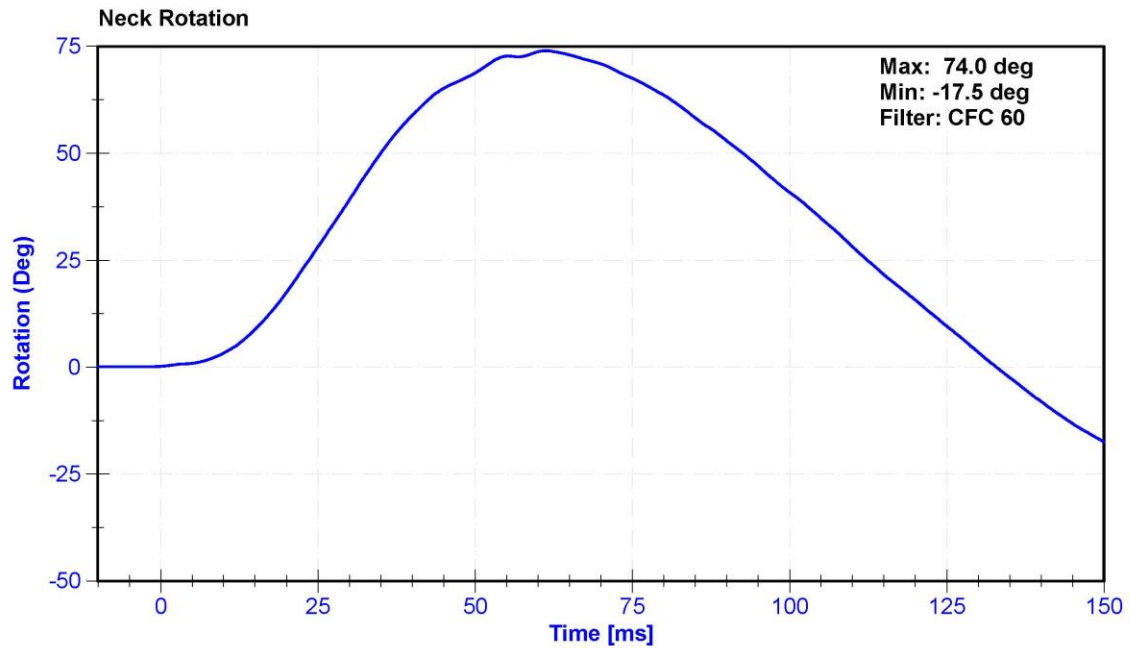

ATD Manufacturer	FTSS	Test Technician	D.Reinhard
ATD Serial Number	DG8012	Laboratory Supervisor	K. Brogan

Results

Test Parameter	Minimum Specification	Maximum Specification	Unit	Result	Pass/Fail
Temperature	20.6	22.2	°C	20.7	Pass
Humidity	10	70	%	56	Pass
Velocity	4.2	4.4	m/s	4.35	Pass
Probe Acceleration	13	18	g's	16.3	Pass
Shoulder Deflection	28	37	mm	30.1	Pass
Lateral Upper Spine Acceleration	17	22	g's	20.9	Pass

Transducer Calibrations

Channel	Manufacturer	Serial Number	Calibration Date	Calibration Due Date
Pendulum Accelerometer	MSI 64C-2000	A279031	5/8/2020	5/8/2021
Shoulder Potentiometer	Servo 08TC1-3745	DS-1845GFE	5/6/2020	11/4/2020
Upper Spine Y Accelerometer	ENDEVCO 7264CT	AC-P64148	4/16/2020	10/15/2020

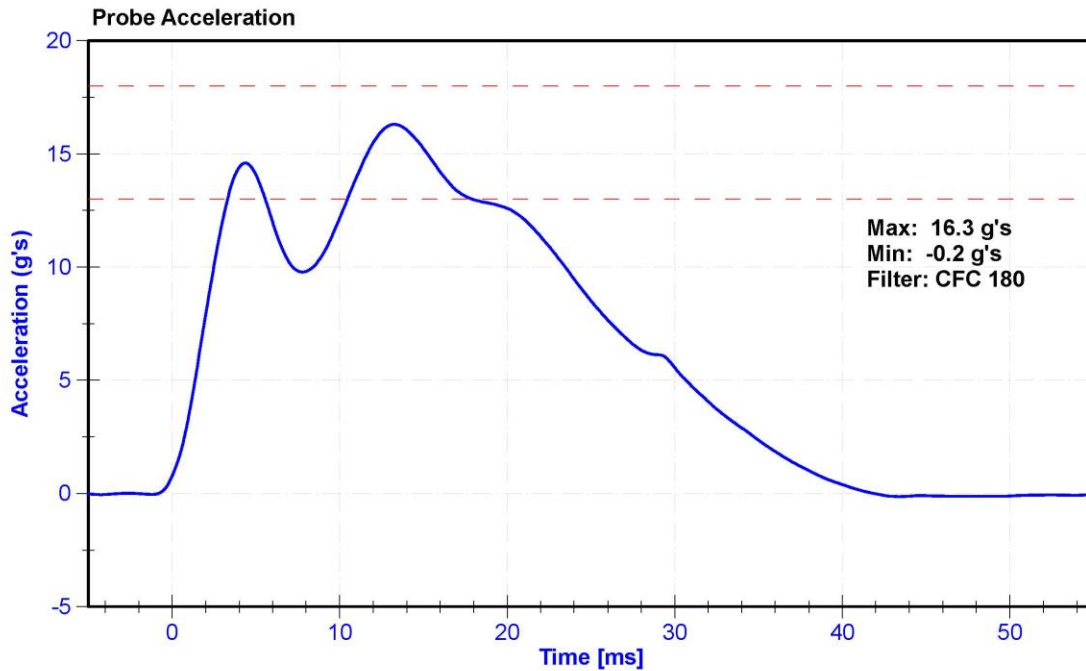

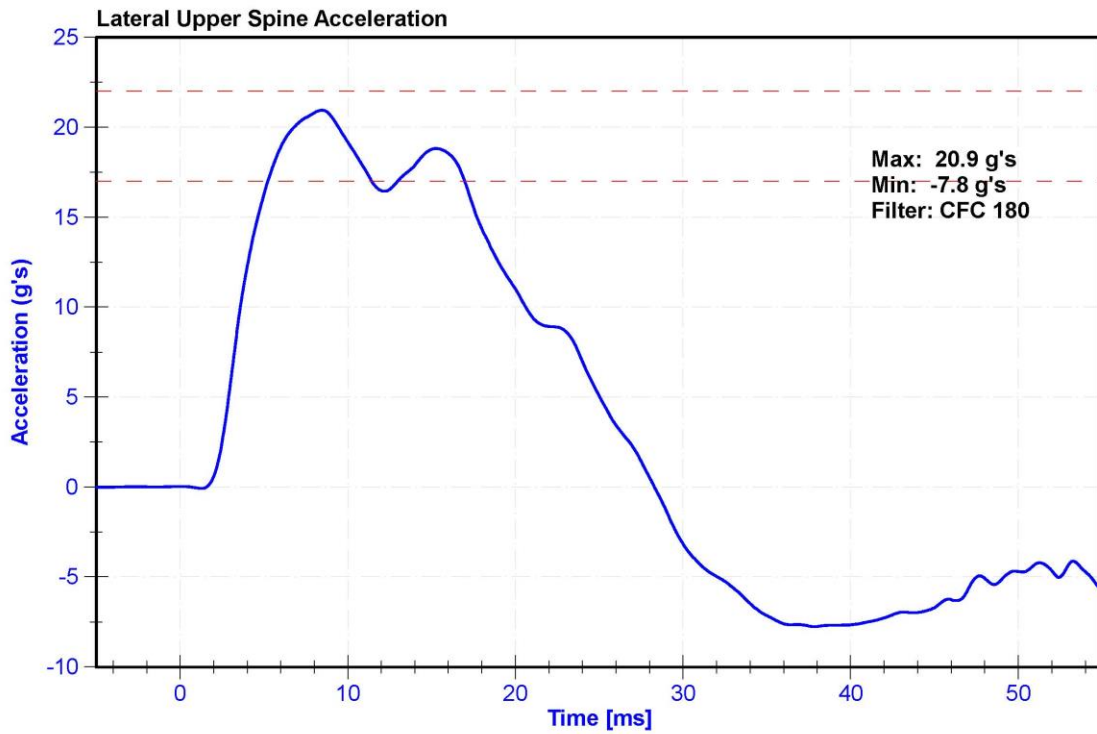
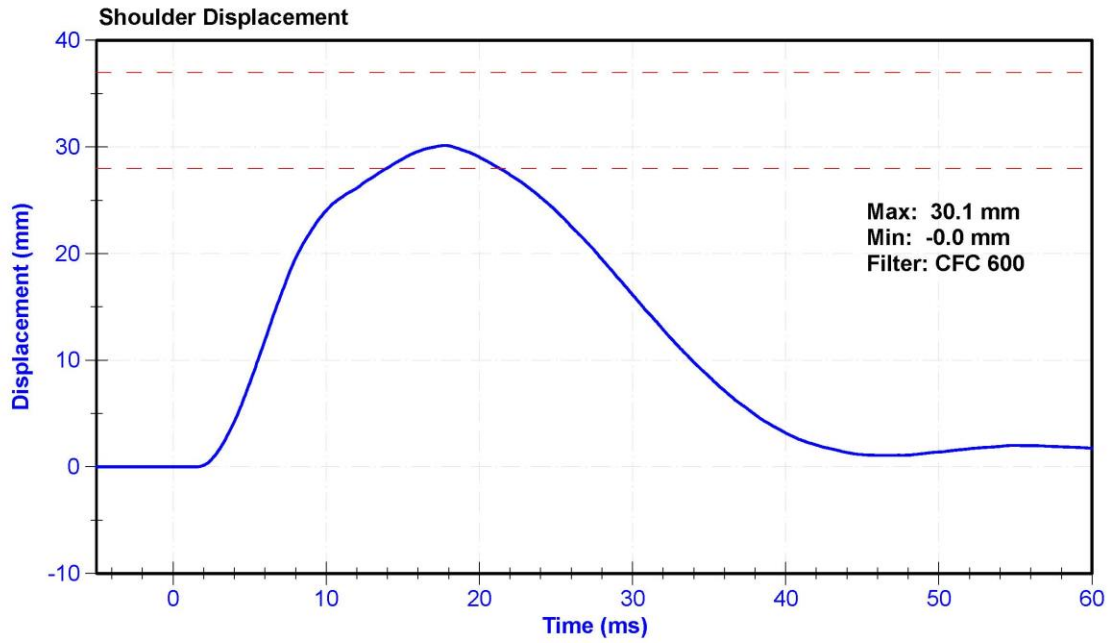

ATD Manufacturer	FTSS	Test Technician	D.Reinhard
ATD Serial Number	DG8012	Laboratory Supervisor	K. Brogan

Results

Test Parameter	Minimum Specification	Maximum Specification	Unit	Result	Pass/Fail
Temperature	20.6	22.2	°C	20.8	Pass
Humidity	10	70	%	56.0	Pass
Velocity	6.6	6.8	m/s	6.60	Pass
Probe Acceleration after 5 ms	30	36	g's	35.4	Pass
Lateral Upper Spine Acceleration	34	43	g's	38.7	Pass
Lateral Lower Spine Acceleration	29	37	g's	34.1	Pass
Shoulder Deflection	31	40	mm	31.5	Pass
Upper Thorax Rib Deflection	25	32	mm	25.2	Pass
Mid Thorax Rib Deflection	30	36	mm	30.8	Pass
Lower Thorax Rib Deflection	32	38	mm	33.9	Pass

Transducer Calibrations

Channel	Manufacturer	Serial Number	Calibration Date	Calibration Due Date
Pendulum Accelerometer	MSI 64C-2000	A279031	5/8/2020	5/8/2021
Upper Spine T1 Y Accelerometer	ENDEVCO 7264CT	AC-P64148	4/16/2020	10/15/2020
Upper Spine T12 Y Accelerometer	ENDEVCO 7264C-2K-TZ2	AC-P51327	4/16/2020	10/15/2020
Shoulder Potentiometer	Servo 08TC1-3745	DS-1845GFE	5/6/2020	11/4/2020
Upper Thorax Rib Potentiometer	Servo 1246	DS-2165GFE	5/6/2020	11/4/2020
Middle Thorax Rib Potentiometer	Servo 08TC1-3621	DS-45 GFE	5/6/2020	11/4/2020
Lower Thorax Rib Potentiometer	Servo 08TC1-3787	DS-011GFE	5/6/2020	11/4/2020

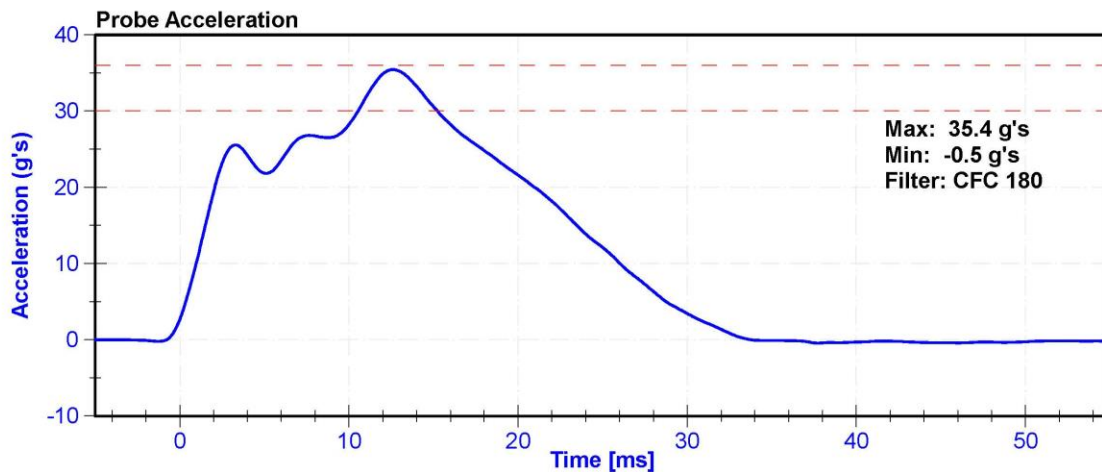

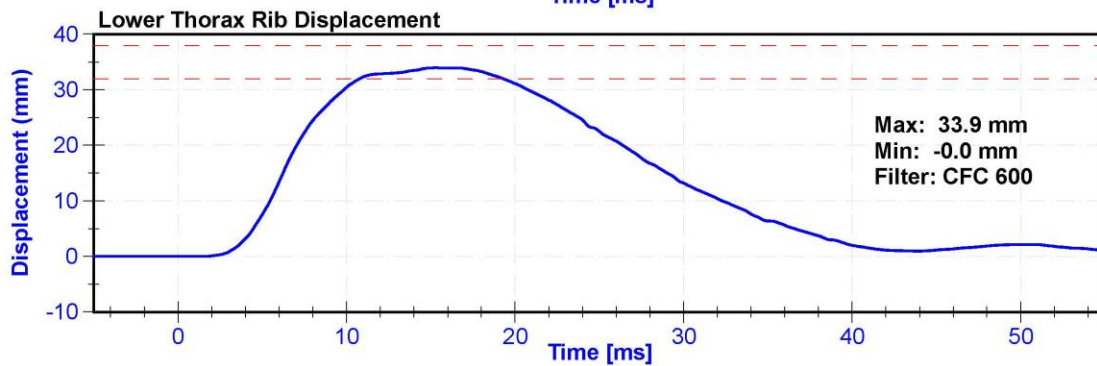
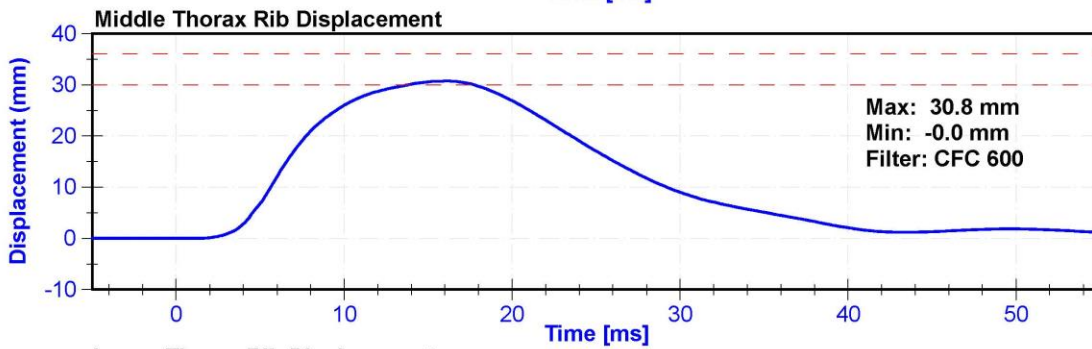
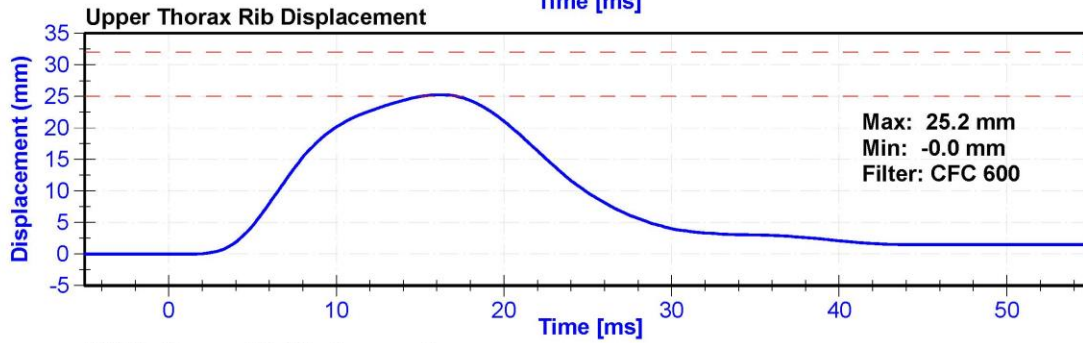
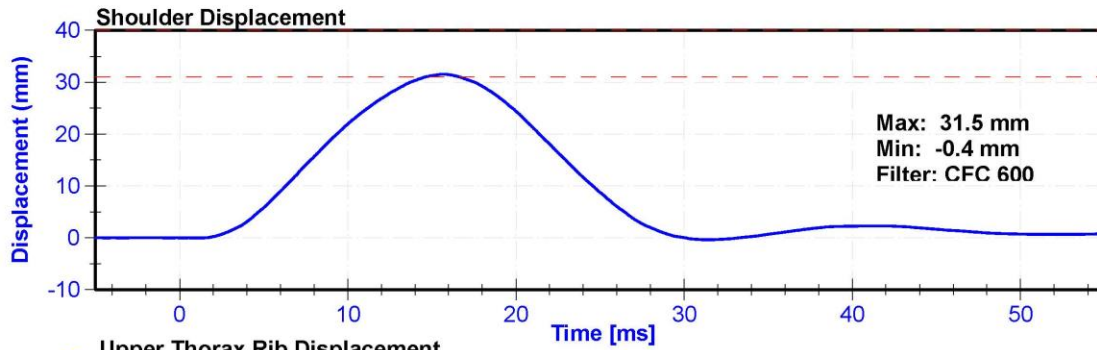

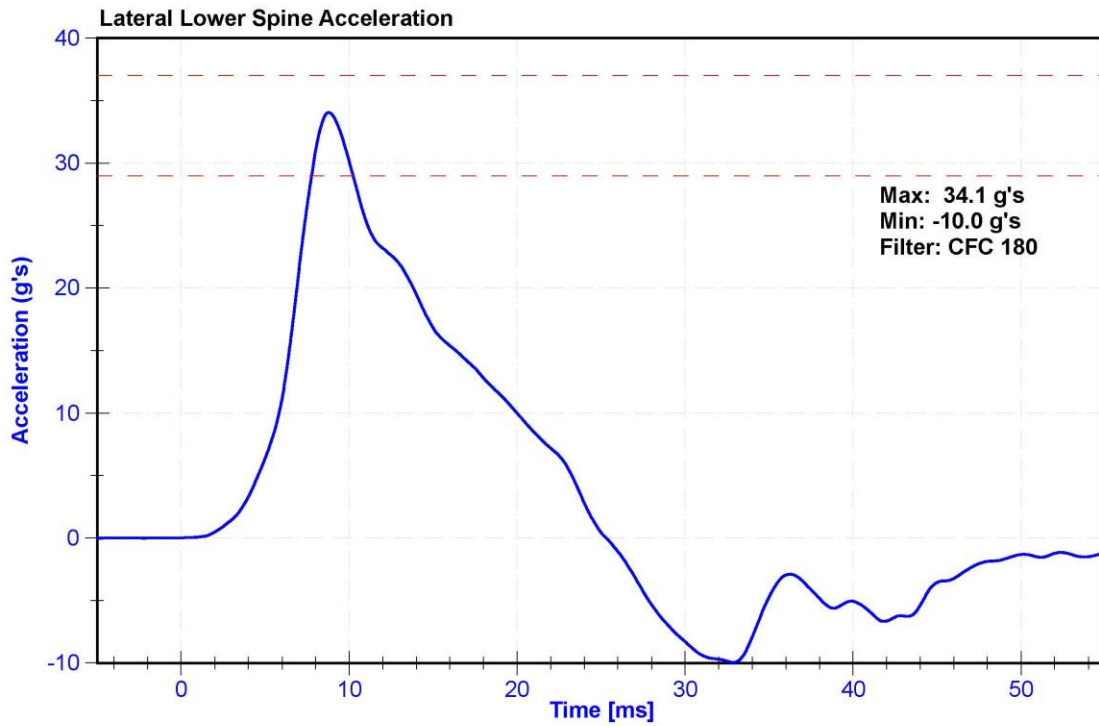
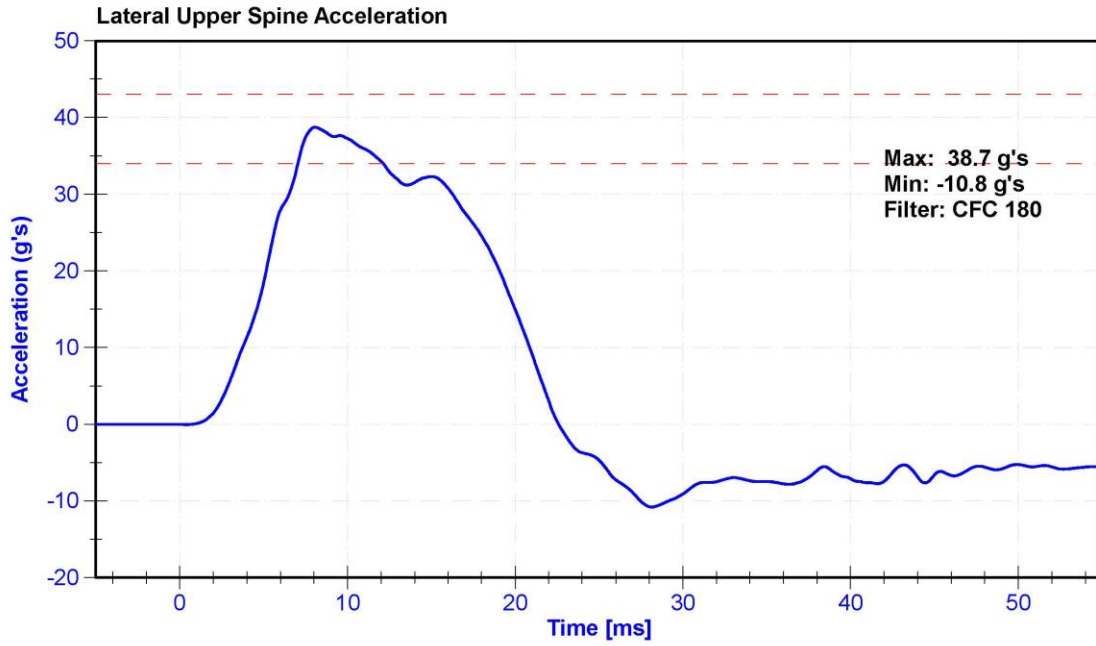

ATD Manufacturer	FTSS	Test Technician	D.Reinhard
ATD Serial Number	DG8012	Laboratory Supervisor	K. Brogan

Results

Test Parameter	Minimum Specification	Maximum Specification	Unit	Result	Pass/Fail
Temperature	20.6	22.2	°C	20.8	Pass
Humidity	10	70	%	56	Pass
Velocity	4.2	4.4	m/s	4.31	Pass
Probe Acceleration	14	18	g's	16.0	Pass
Lateral Upper Spine Acceleration	13	17	g's	14.7	Pass
Lateral Lower Spine Acceleration	7	11	g's	9.3	Pass
Upper Thorax Rib Deflection	32	40	mm	36.3	Pass
Middle Thorax Rib Deflection	39	45	mm	42.3	Pass
Lower Thorax Rib Deflection	35	43	mm	40.1	Pass

Transducer Calibrations

Channel	Manufacturer	Serial Number	Calibration Date	Calibration Due Date
Pendulum Accelerometer	MSI 64C-2000	A279031	5/8/2020	5/8/2021
Upper Spine Y Accelerometer	ENDEVCO 7264CT	AC-P64148	4/16/2020	10/15/2020
Lower Spine Y Accelerometer	ENDEVCO 7264C-2K-TZ2	AC-P51327	4/16/2020	10/15/2020
Upper Thorax Rib Potentiometer	Servo 1246	DS-2165GFE	5/6/2020	11/4/2020
Middle Thorax Rib Potentiometer	Servo 08TC1-3621	DS-45 GFE	5/6/2020	11/4/2020
Lower Thorax Rib Potentiometer	Servo 08TC1-3787	DS-011GFE	5/6/2020	11/4/2020

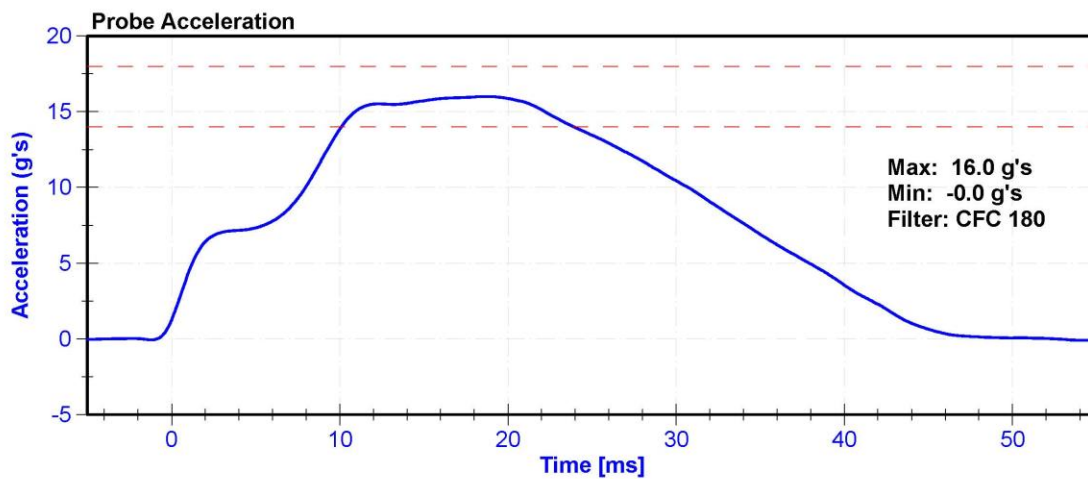

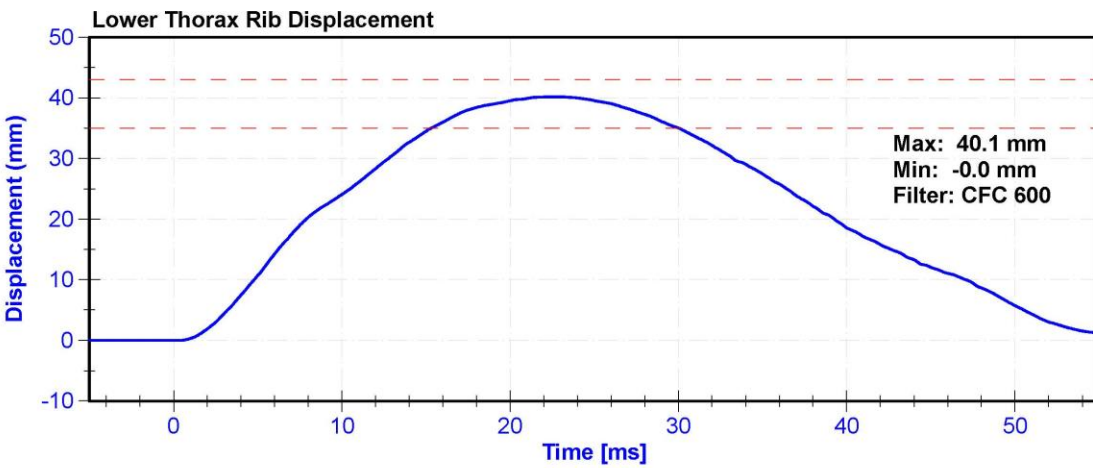
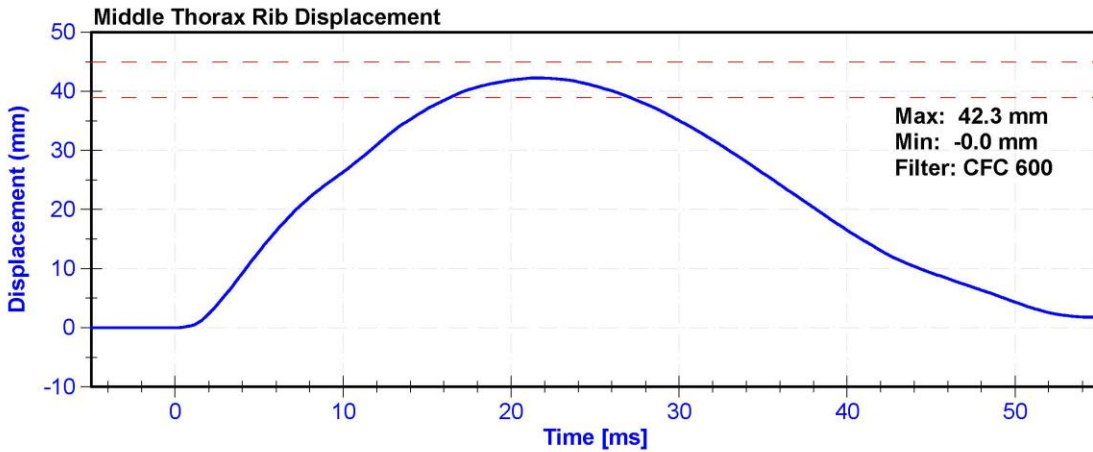
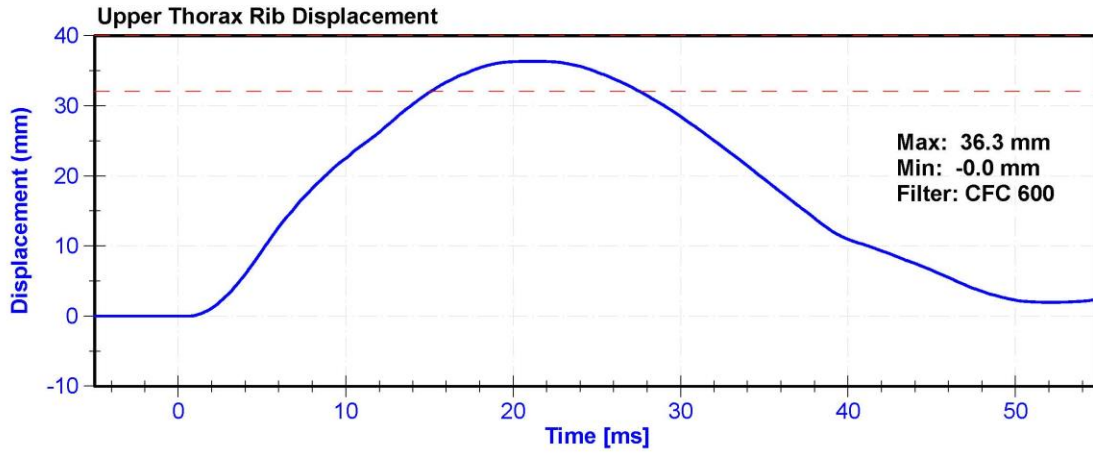

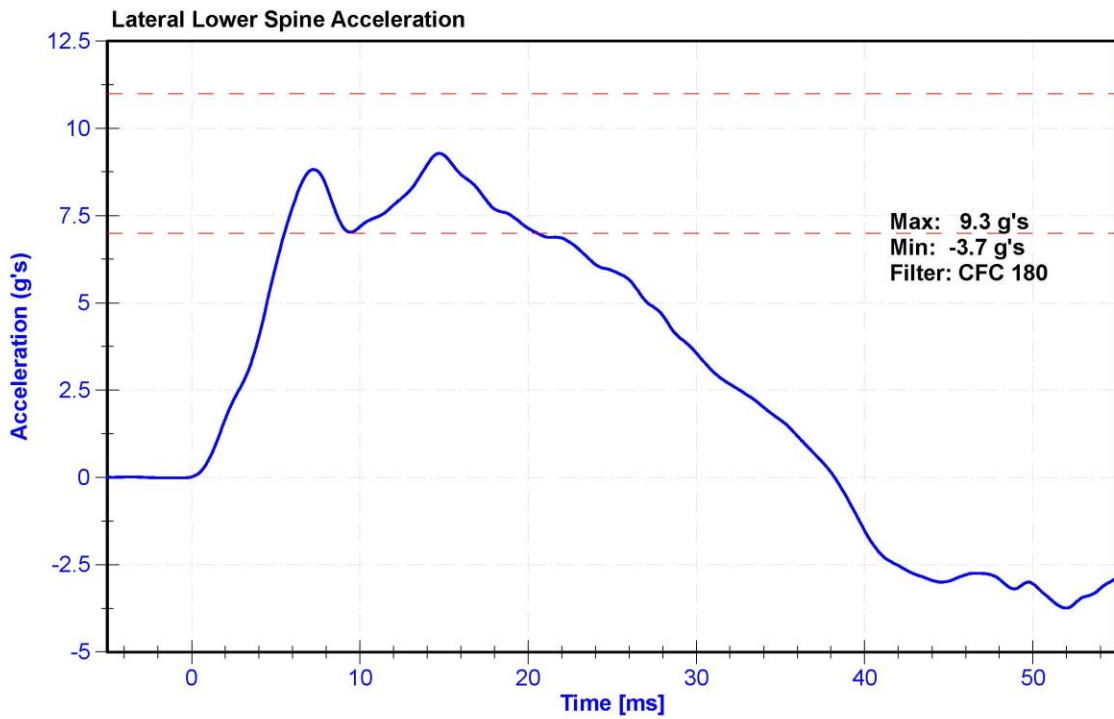
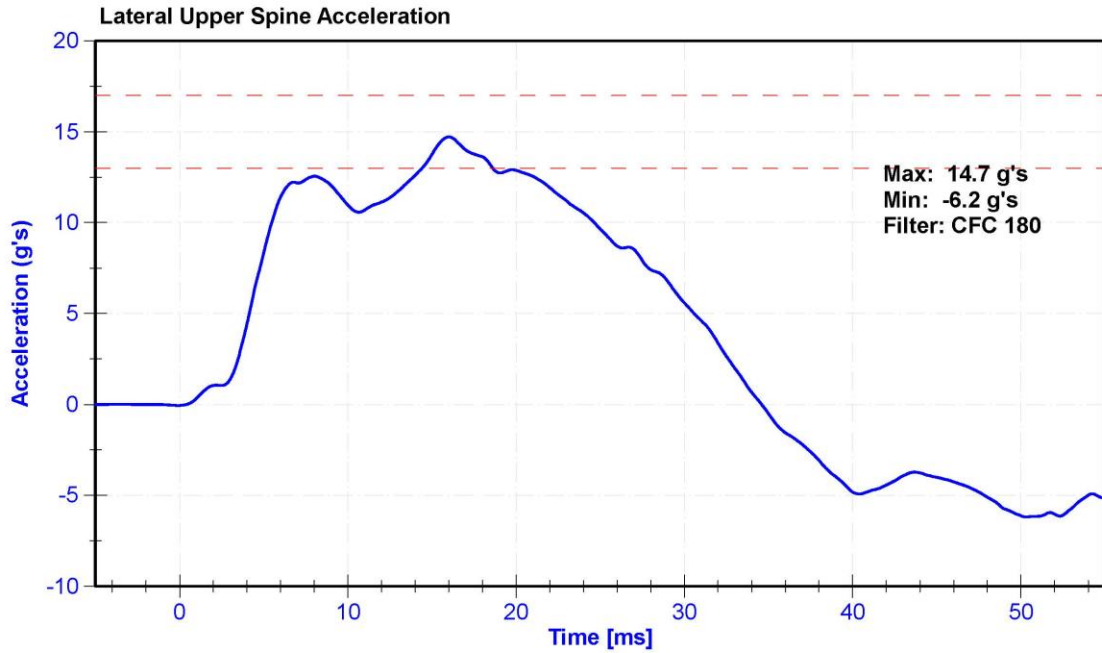

ATD Manufacturer	FTSS	Test Technician	D,Reinhard
ATD Serial Number	DG8012	Laboratory Supervisor	K. Brogan

Results

Test Parameter	Minimum Specification	Maximum Specification	Unit	Result	Pass/Fail
Temperature	20.6	22.2	°C	20.7	Pass
Humidity	10	70	%	55.0	Pass
Velocity	4.2	4.4	m/s	4.31	Pass
Probe Acceleration	12	16	g's	14.7	Pass
Lateral Lower Spine Acceleration	9	14	g's	10.7	Pass
Upper Abdomen Rib Deflection	36	47	mm	42.6	Pass
Lower Abdomen Rib Deflection	33	44	mm	40.9	Pass

Transducer Calibrations

Channel	Manufacturer	Serial Number	Calibration Date	Calibration Due Date
Probe Accelerometer	MSI 64C-2000	A279031	5/8/2020	5/8/2021
Lower Spine Y Accelerometer	ENDEVCO 7264C	AC-P51327	4/16/2020	10/15/2020
Upper Abdomen Rib Potentiometer	Servo 08TC1-3725	DS-008GFE	5/6/2020	11/4/2020
Lower Abdomen Rib Potentiometer	Servo 08TC1-3745	DS-1774GFE	5/6/2020	11/4/2020

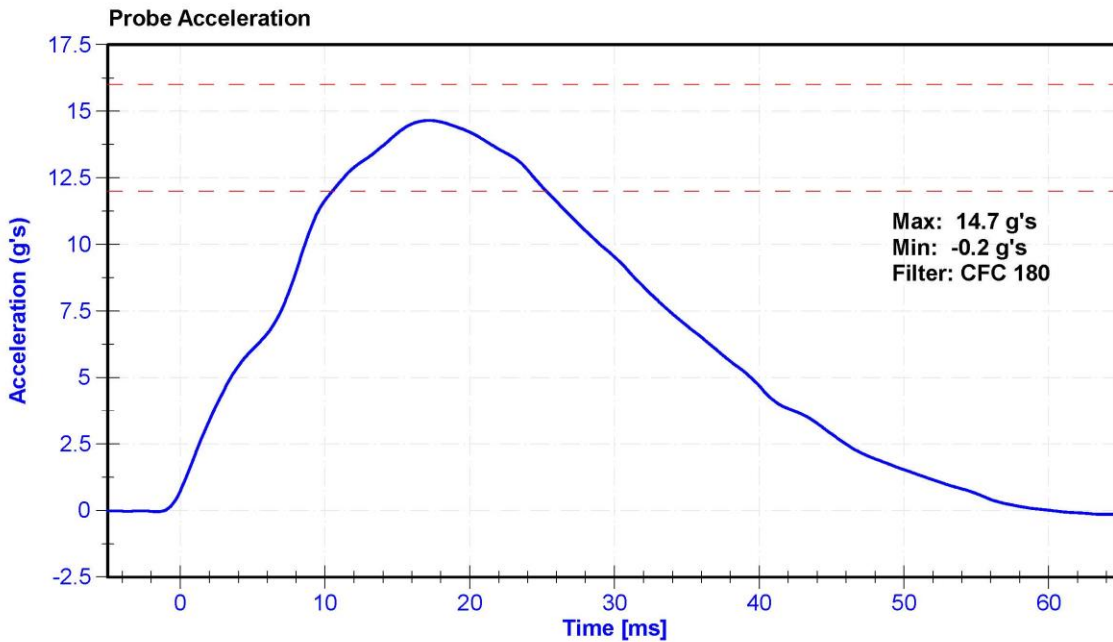

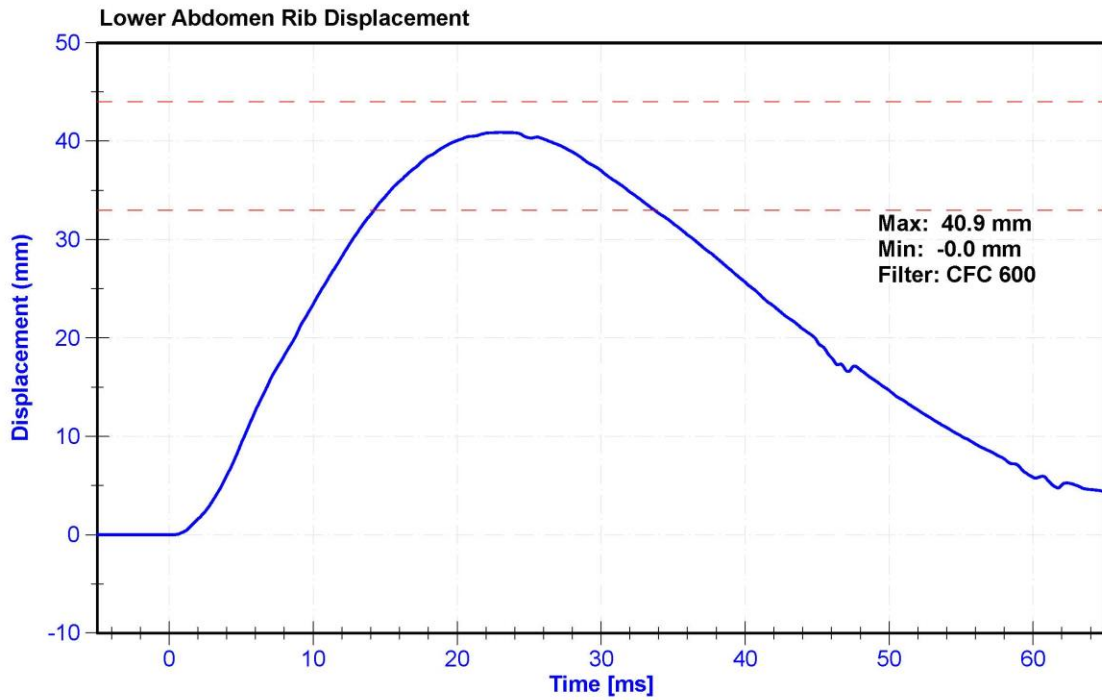
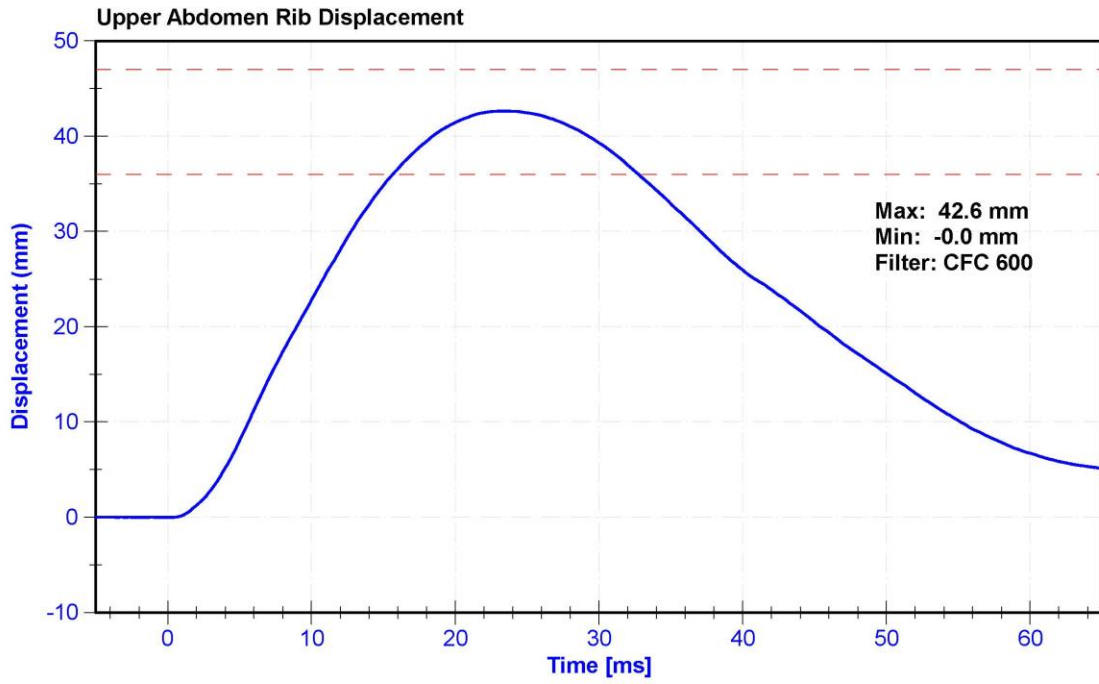

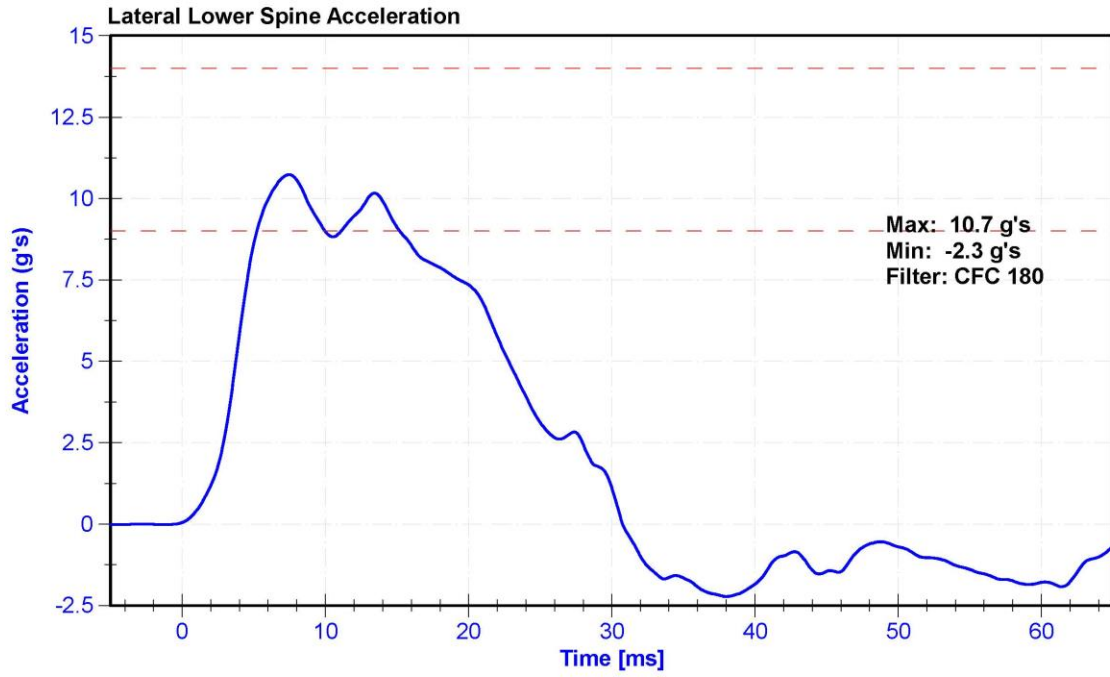

ATD Manufacturer	FTSS	Test Technician	D.Reinhard
ATD Serial Number	DG8012	Laboratory Supervisor	K. Brogan

Results

Test Parameter	Minimum Specification	Maximum Specification	Unit	Result	Pass/Fail
Temperature	20.6	22.2	°C	20.7	Pass
Humidity	10	70	%	56	Pass
Velocity	6.6	6.8	m/s	6.67	Pass
Probe Acceleration	38	47	g's	45.6	Pass
Lateral Pelvis Acceleration after 6ms	34	42	g's	41.8	Pass
Acetabulum Force	3600	4300	N	4079.2	Pass

Transducer Calibrations

Channel	Manufacturer	Serial Number	Calibration Date	Calibration Due Date
Pendulum Accelerometer	MSI 64C-2000	A279031	5/8/2020	5/8/2021
Pelvis Y Accelerometer	ENDEVCO 7264C	AC-P51875	4/16/2020	10/15/2020
Acetabulum Load Cell	Denton 3249J	LC-267Fy	3/19/2020	3/19/2021
Certification Plug	SACO	13177	8/8/2019	N/A
Crash Test Plug	SACO	13224	8/12/2019	N/A

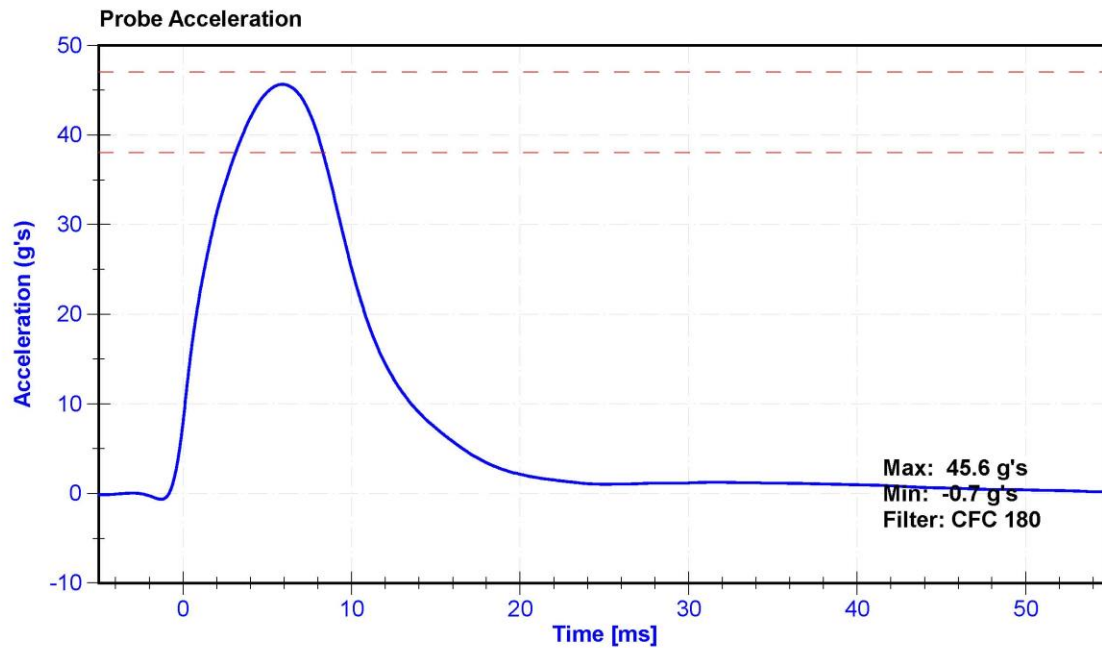

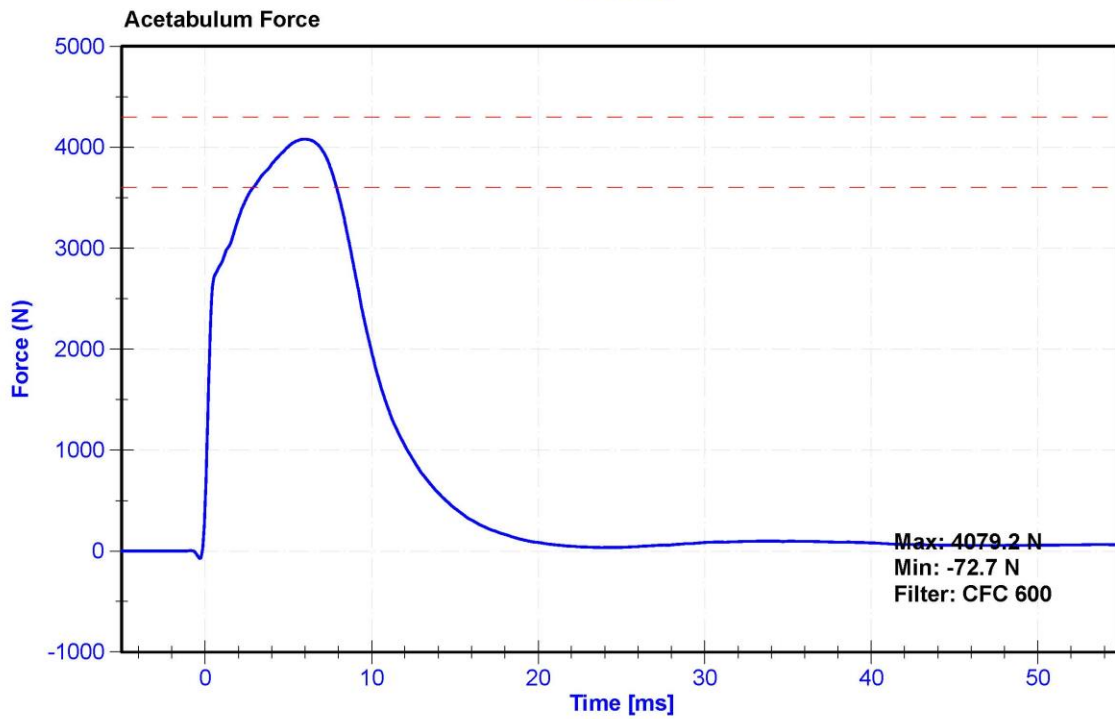
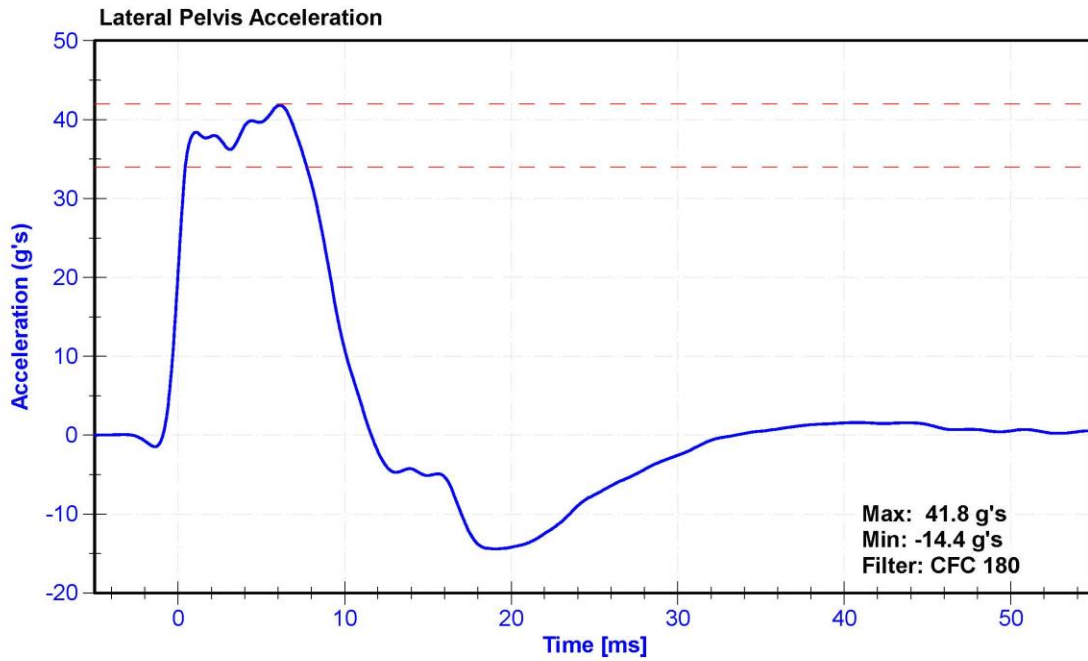



DE 8012
Crash
8/17/19

SID-lis Pelvis Plug Certification Test

Plug S/N 13224
Test Number 10646
Report Number 10682
Test Date 8/12/2019 7:39:03 AM

Test Results	Spec Min	Spec Max
Force @ 0.5 mm (N)	50.00	600.00
Force @ 1.5 mm (N)	850.00	1,400.00
Force @ 2.5 mm (N)	1,306.00	1,618.00
Force @ 3.0 mm (N)	1,361.00	1,673.00

Testing Machine STM-20 5965542
 Load Cell S/N (F1360947), Units (LBS) 1000
 Crosshead Speed (mm/min) or Rate 12.7
 Extension or Position Measured by XHD_100 (XHD100)

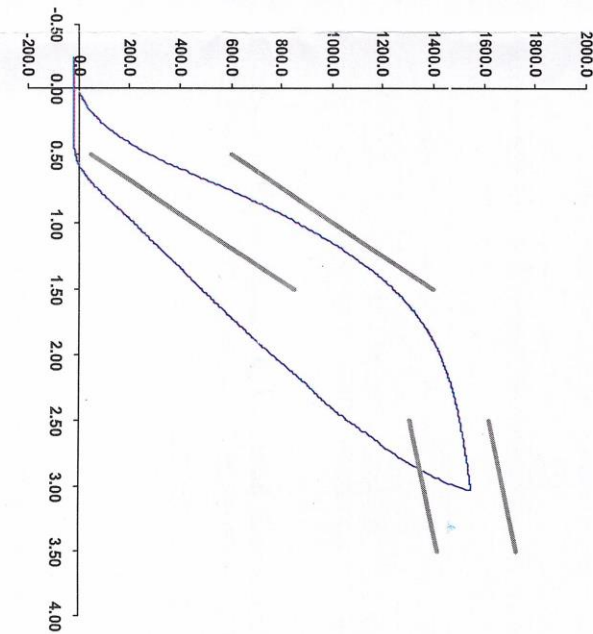

Notes:

Operator

Part Number 180-4450

Template No 107 12-Aug-19
 SACO Research

By: DC Date: 8/12/2019
 SACO Research 41735 Elm St, #401 Murrieta, CA 92562 Tel 310-694-2082 FAX



DC 8/17/19
certified

SID-11s Pelvis Plug Certification Test

Plug S/N 13177
Test Number 10572
Report Number 10607
Test Date 8/8/2019 11:18:09 AM

Test Results	Spec Min	Spec Max
Force @ 0.5 mm (N)	50.00	600.00
Force @ 1.5 mm (N)	850.00	1,400.00
Force @ 2.5 mm (N)	1,306.00	1,618.00
Force @ 3.0 mm (N)	1,361.00	1,673.00

Testing Machine STM-20 5965542
 Load Cell S/N (F1360947), Units (LBS) 1000
 Crosshead Speed (mm/min) or Rate 12.7
 Extension or Position Measured by XHD_100 (XHD100)

Notes:

Operator 131
 Part Number 180-4450
 Template No 107 08-Aug-19
 SACO Research

By: DC Date: 8/8/2019
 SACO Research 41735 Elm St, #401 Murrieta, CA 92562 Tel 310-694-2082 FAX

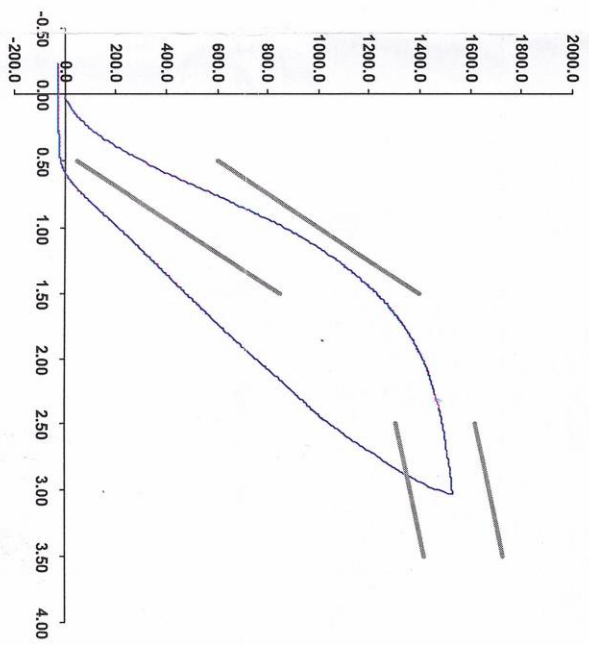

ATD Manufacturer	FTSS	Test Technician	D.Reinhard
ATD Serial Number	DG8012	Laboratory Supervisor	K. Brogan

Results

Test Parameter	Minimum Specification	Maximum Specification	Unit	Result	Pass/Fail
Temperature	20.6	22.2	°C	20.7	Pass
Humidity	10	70	%	59.0	Pass
Velocity	4.2	4.4	m/s	4.39	Pass
Probe Acceleration	36	45	g's	40.6	Pass
Lateral Pelvis Acceleration	28	39	g's	31.6	Pass
Iliac Force	4100	5100	N	4336.0	Pass

Transducer Calibrations

Channel	Manufacturer	Serial Number	Calibration Date	Calibration Due Date
Pendulum Accelerometer	MSI 64C-2000	A279031	5/8/2020	5/8/2021
Pelvis Y Accelerometer	ENDEVCO 7264C-2K-TZ2	AC-P51875	4/16/2020	10/15/2020
Iliac Load Cell	DENTON 3228J	LC-290Fy	9/25/2019	9/24/2020

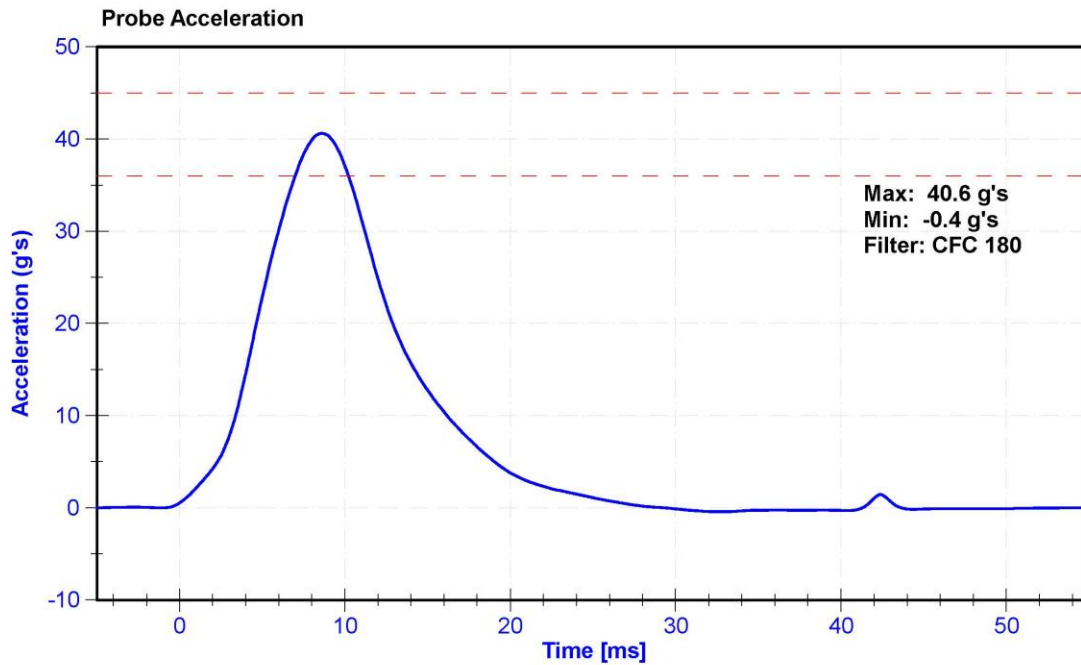

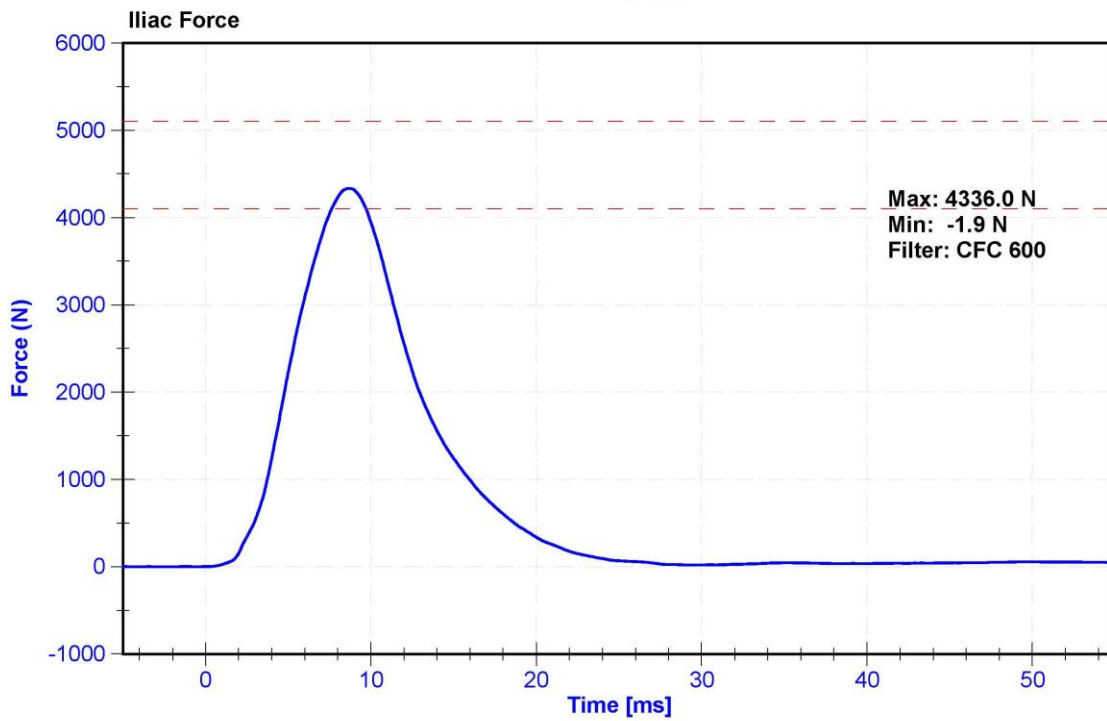
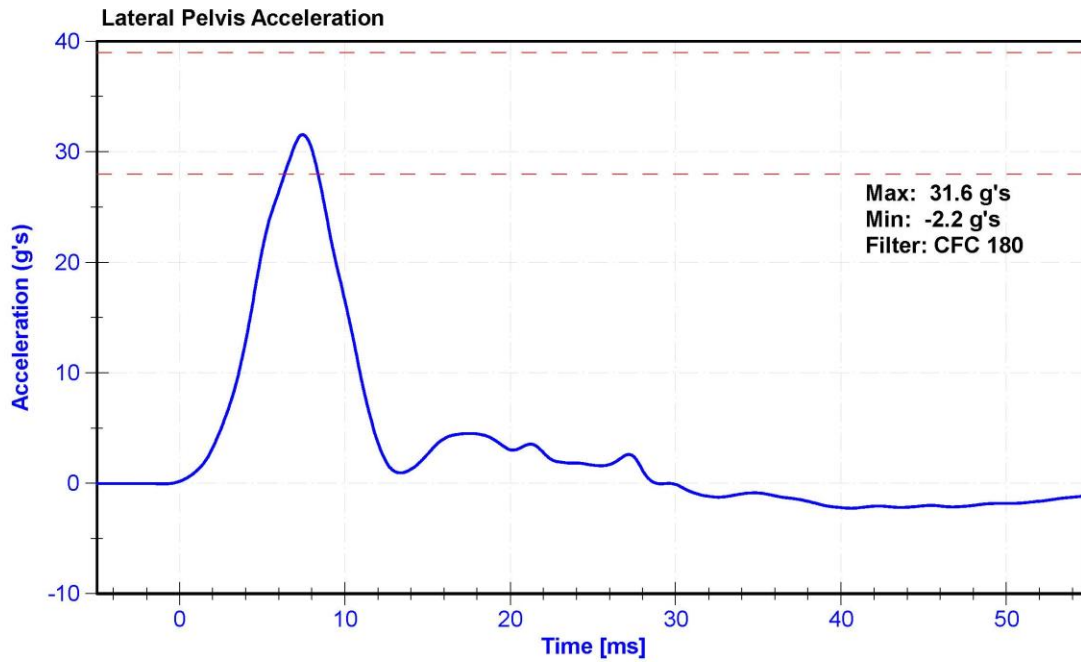

CALIBRATION TEST RESULTS

POST-TEST

SID-IIS 5TH PERCENTILE FEMALE - DRIVER ATD

SERIAL NO: DG8012

(CONFIGURED FOR LEFT SIDE IMPACT)



External Measurements - SID-IIs

Technician: K. Dutton

Date: 08/25/2020

Dummy Serial Number: DG8012

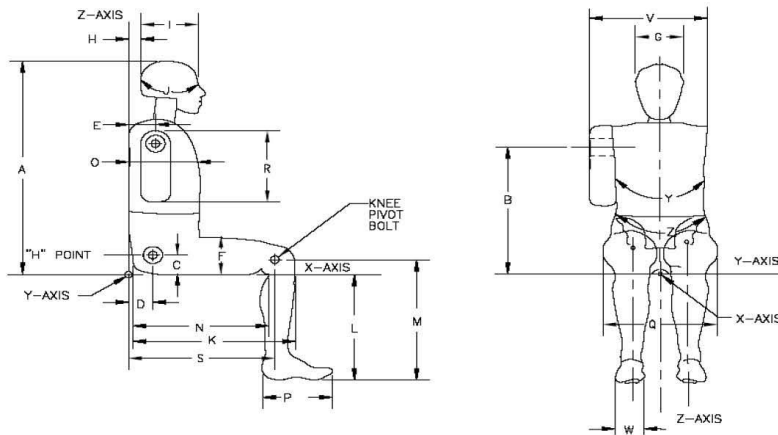

Symbol	Description	Specification (mm)		Result (mm)	Pass/Fail
A	Sitting Height	772	788	779	Pass
B	Shoulder Pivot Height	437	453	446	Pass
C	H-point Height	79	89	84	Pass
D	H-point from seatback	141	151	146	Pass
E	Shoulder Pivot from Backline	97	107	103	Pass
F	Thigh Clearance	119	135	127	Pass
G	Head Breadth	140	148	144	Pass
H	Head Back from Backline	40	46	44	Pass
I	Head Depth	178	188	184	Pass
J	Head Circumference	541	551	548	Pass
K	Buttock to Knee Length	514	540	533	Pass
L	Popliteal Height	343	369	357	Pass
M	Knee Pivot to floor height	392	409	402	Pass
N	Buttock Popliteal Length	416	442	433	Pass
O	Chest Depth w/o jacket	195	211	204	Pass
P	Foot Length	216	232	225	Pass
Q	Hip Breadth (w/pelvic plugs)	313	323	319	Pass
R	Arm Length	249	259	255	Pass
S	Knee Joint to seatback	477	493	486	Pass
V	Shoulder Width	341	357	346	Pass
W	Foot Width	78	94	85	Pass
Y	Chest Circumference w/jacket	851	881	867	Pass
Z	Waist Circumference	761	791	781	Pass

ATD Manufacturer	FTSS	Test Technician	E. Helenbrook
ATD Serial Number	DG8012	Laboratory Supervisor	K. Brogan

Results

Test Parameter	Minimum Specification	Maximum Specification	Unit	Result	Pass/Fail
Temperature	20.6	22.2	°C	21.5	Pass
Humidity	10	70	%	55.8	Pass
Resultant Acceleration	115	137	g's	128.6	Pass
Oscillation	0	15	%	1.4	Pass
Fore-Aft Acceleration	-15	15	g's	-3.6	Pass

Transducer Calibrations

Channel	Manufacturer	Serial Number	Calibration Date	Calibration Due Date
X Accelerometer	ENDEVCO 7264	AC-P74788	4/16/2020	10/15/2020
Y Accelerometer	ENDEVCO 7264CT	AC-P83432	4/16/2020	10/15/2020
Z Accelerometer	ENDEVCO 7264	AC-P83319	4/16/2020	10/15/2020

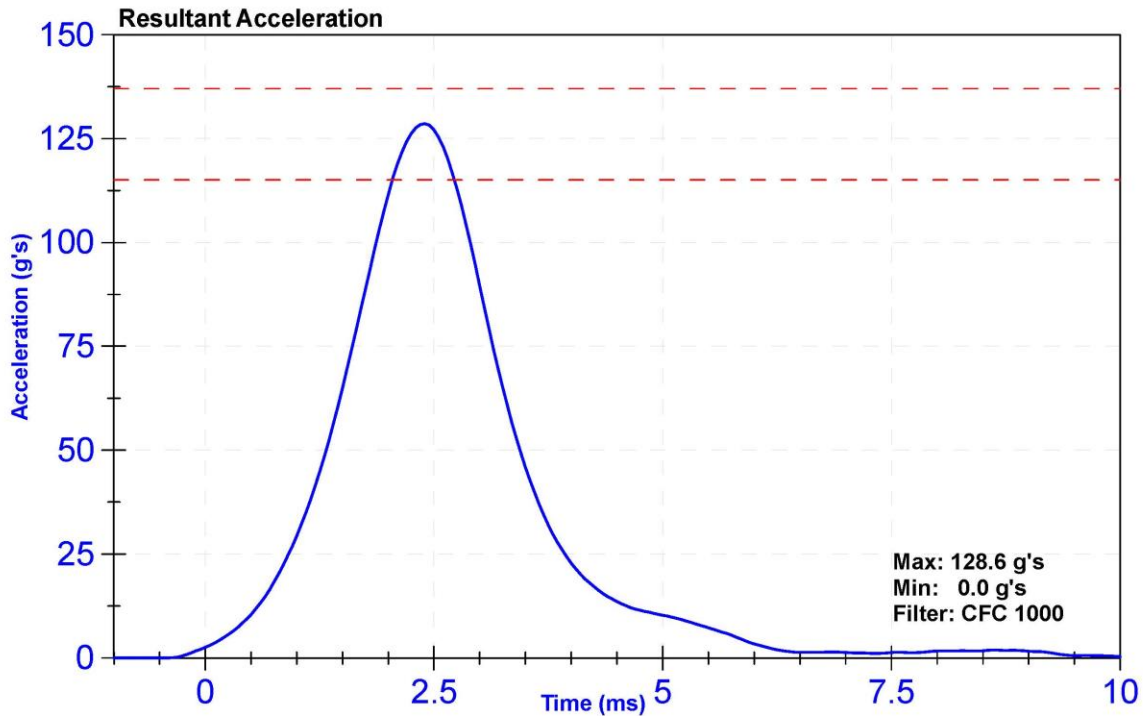

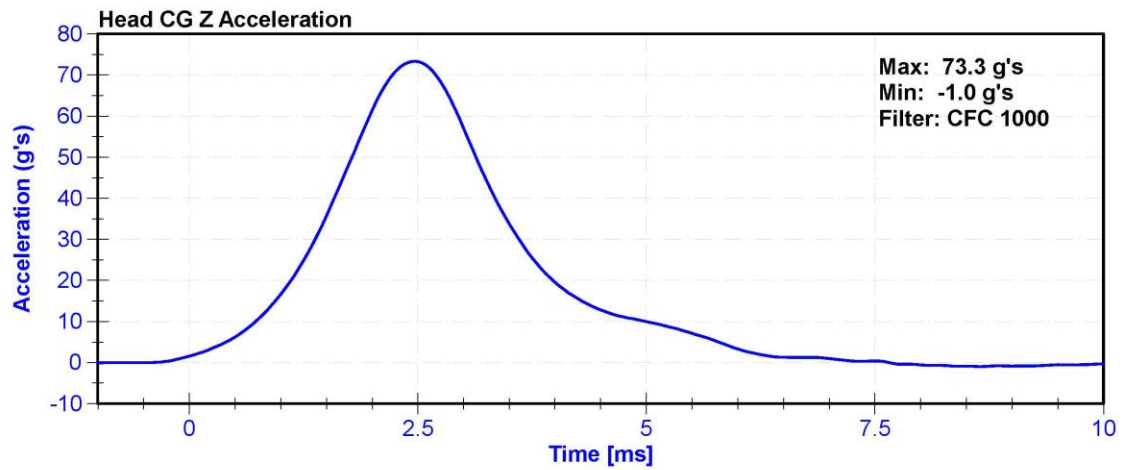
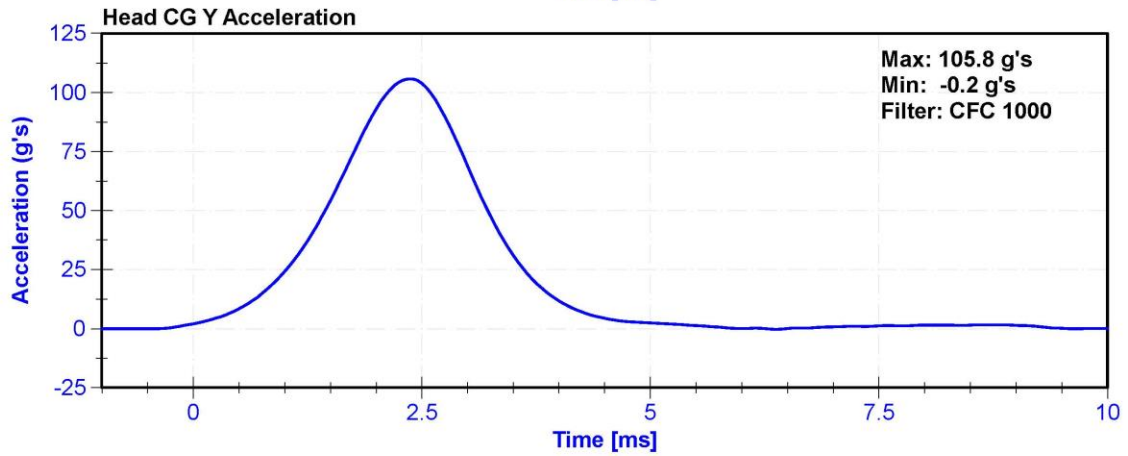
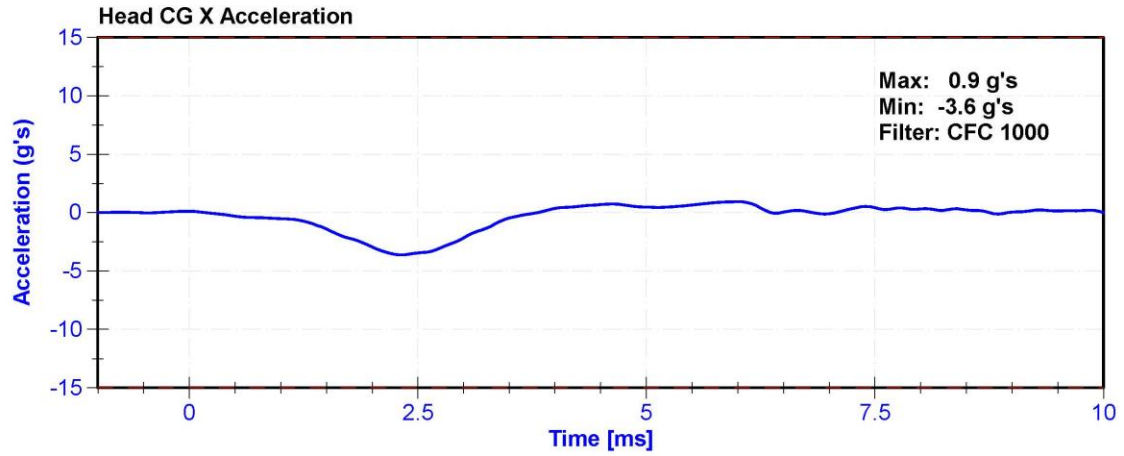

ATD Manufacturer	FTSS	Test Technician	K. Dutton
ATD Serial Number	DG8012	Laboratory Supervisor	K. Brogan

Results

Test Parameter	Minimum Specification	Maximum Specification	Unit	Result	Pass/Fail
Temperature	20.6	22.2	°C	21.3	Pass
Humidity	10	70	%	62.3	Pass
Velocity	5.51	5.63	m/s	5.584	Pass
Pendulum Impulse at 10ms	2.2	2.8	m/s	2.36	Pass
Pendulum Impulse at 15ms	3.3	4.1	m/s	3.46	Pass
Pendulum Impulse at 20ms	4.4	5.4	m/s	4.60	Pass
Pendulum Impulse at 25ms	5.4	6.1	m/s	5.54	Pass
Pendulum Impulse from 25 to 100ms	5.5	6.2	m/s	5.96	Pass
Neck Rotation	71	81	deg	77.8	Pass
Time at Maximum Rotation	50	70	ms	60.5	Pass
Moment about the OC	36	44	Nm	43.7	Pass
Moment Decay to 0 Nm	102	126	ms	113.3	Pass

Transducer Calibrations

Channel	Manufacturer	Serial Number	Calibration Date	Calibration Due Date
Pendulum Accelerometer	ENDEVCO 7231CT	AC-C16503 Striker	2/6/2020	2/5/2021
Pendulum Potentiometer	Denton 78051-342	DS-184Pend	11/4/2019	11/3/2020
Condyle Potentiometer	Denton 78051-342	DS-185Pend	11/4/2019	11/3/2020
Upper Neck Load Cell	Denton 1716	17162019 FY	3/18/2020	3/18/2021

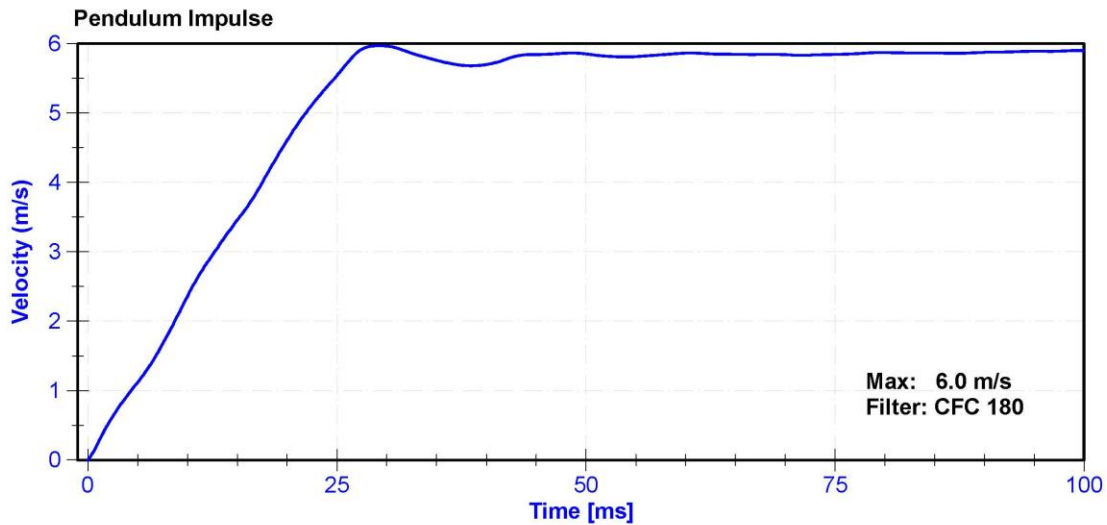

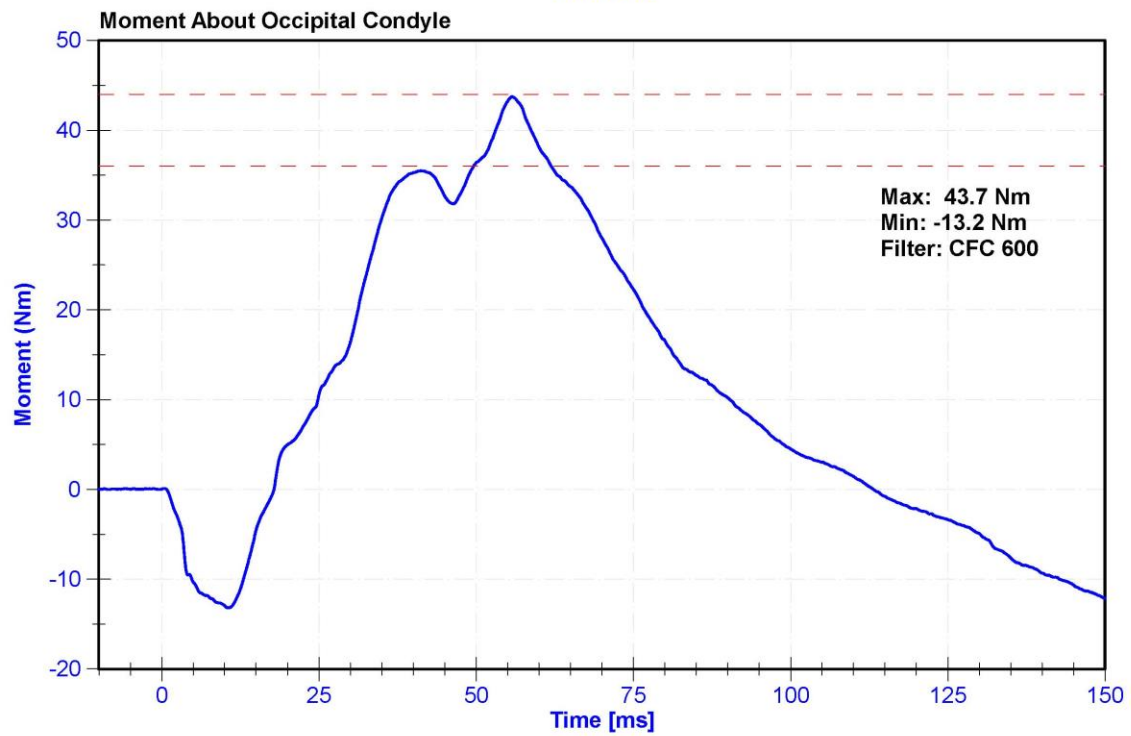
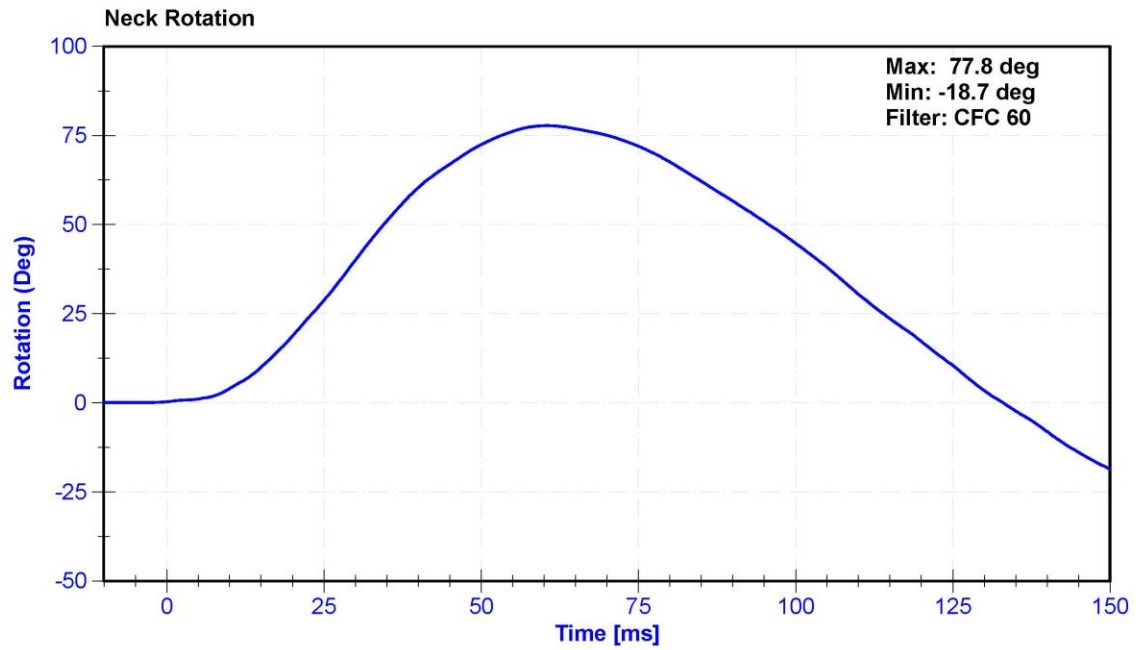

ATD Manufacturer	FTSS	Test Technician	D.Reinhard
ATD Serial Number	DG8012	Laboratory Supervisor	K. Brogan

Results

Test Parameter	Minimum Specification	Maximum Specification	Unit	Result	Pass/Fail
Temperature	20.6	22.2	°C	20.8	Pass
Humidity	10	70	%	59	Pass
Velocity	4.2	4.4	m/s	4.34	Pass
Probe Acceleration	13	18	g's	15.8	Pass
Shoulder Deflection	28	37	mm	29.9	Pass
Lateral Upper Spine Acceleration	17	22	g's	20.5	Pass

Transducer Calibrations

Channel	Manufacturer	Serial Number	Calibration Date	Calibration Due Date
Pendulum Accelerometer	MSI 64C-2000	A286228	1/29/2020	1/28/2021
Shoulder Potentiometer	Servo 08TC1-3745	DS-1845GFE	5/6/2020	11/4/2020
Upper Spine Y Accelerometer	ENDEVCO 7264CT	AC-P64148	4/16/2020	10/15/2020

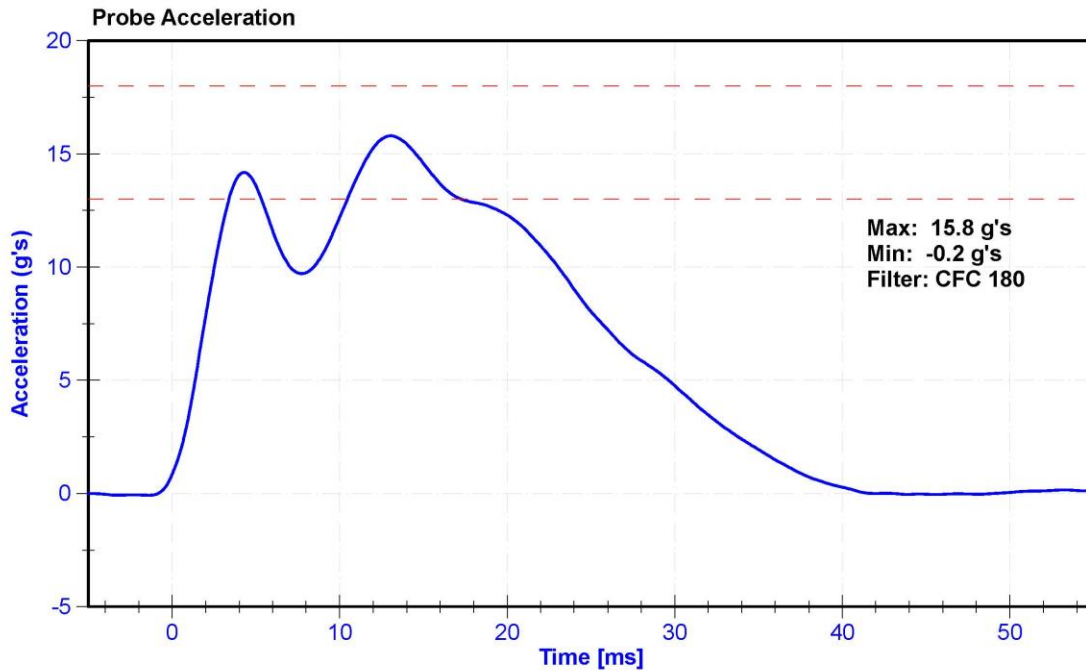

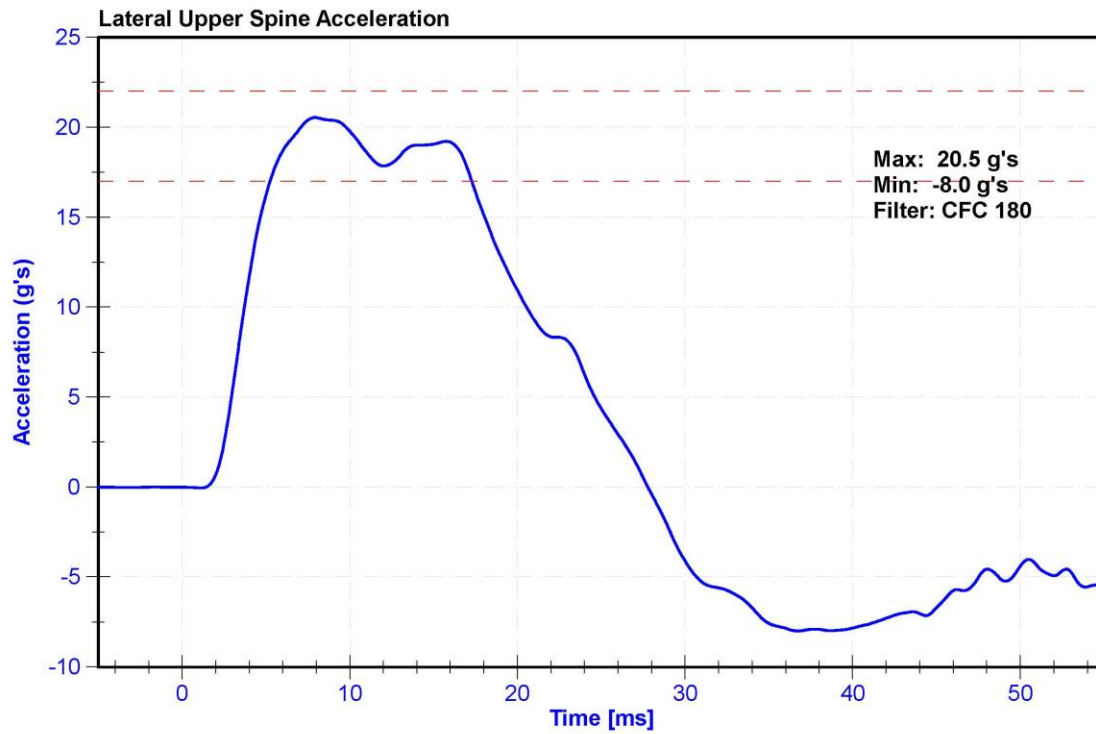
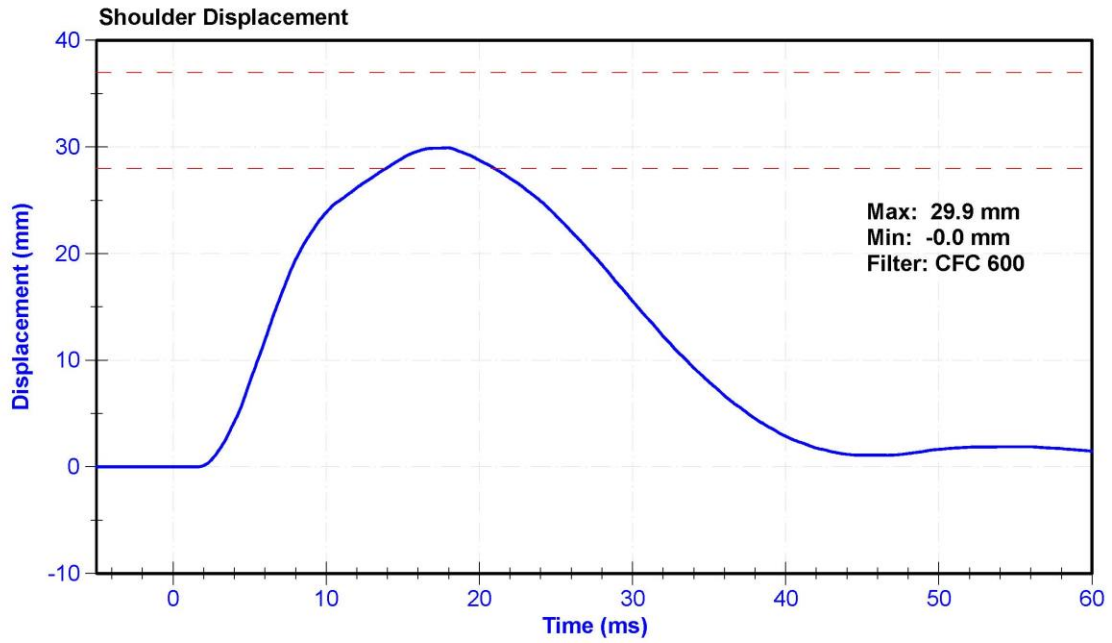

ATD Manufacturer	FTSS	Test Technician	D.Reinhard
ATD Serial Number	DG8012	Laboratory Supervisor	K. Brogan

Results

Test Parameter	Minimum Specification	Maximum Specification	Unit	Result	Pass/Fail
Temperature	20.6	22.2	°C	20.9	Pass
Humidity	10	70	%	62.0	Pass
Velocity	6.6	6.8	m/s	6.67	Pass
Probe Acceleration after 5 ms	30	36	g's	34.8	Pass
Lateral Upper Spine Acceleration	34	43	g's	39.4	Pass
Lateral Lower Spine Acceleration	29	37	g's	34.1	Pass
Shoulder Deflection	31	40	mm	31.9	Pass
Upper Thorax Rib Deflection	25	32	mm	25.5	Pass
Mid Thorax Rib Deflection	30	36	mm	31.0	Pass
Lower Thorax Rib Deflection	32	38	mm	34.1	Pass

Transducer Calibrations

Channel	Manufacturer	Serial Number	Calibration Date	Calibration Due Date
Pendulum Accelerometer	MSI 64C-2000	A286228	1/29/2020	1/28/2021
Upper Spine T1 Y Accelerometer	ENDEVCO 7264CT	AC-P64148	4/16/2020	10/15/2020
Upper Spine T12 Y Accelerometer	ENDEVCO 7264C	AC-P51327	4/16/2020	10/15/2020
Shoulder Potentiometer	Servo 08TC1-3745	DS-1845GFE	5/6/2020	11/4/2020
Upper Thorax Rib Potentiometer	Servo 1246	DS-2165GFE	5/6/2020	11/4/2020
Middle Thorax Rib Potentiometer	Servo 08TC1-3621	DS-45 GFE	5/6/2020	11/4/2020
Lower Thorax Rib Potentiometer	Servo 08TC1-3787	DS-011GFE	5/6/2020	11/4/2020

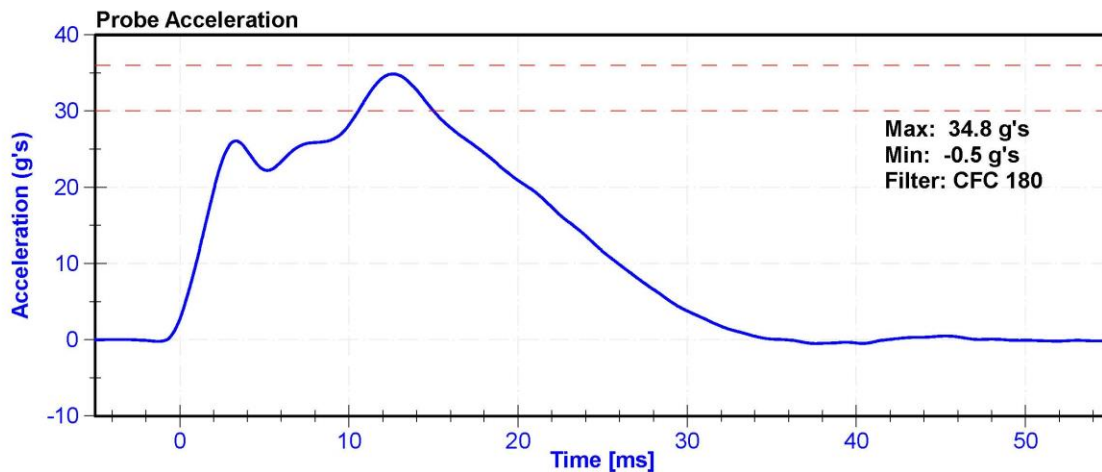

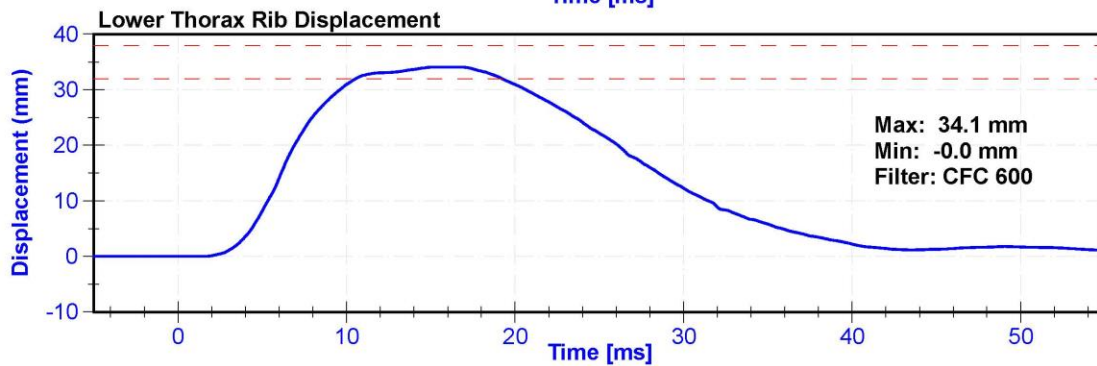
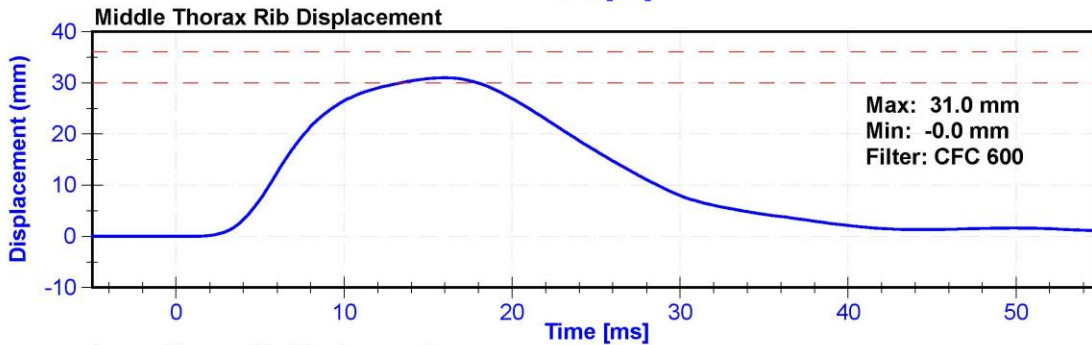
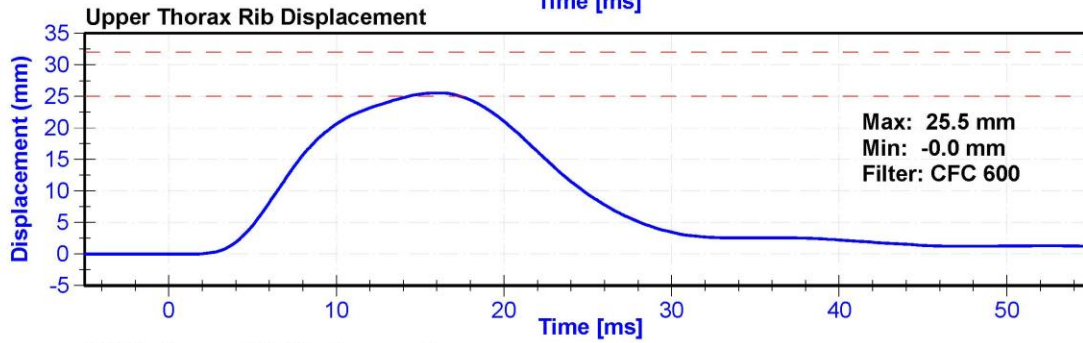
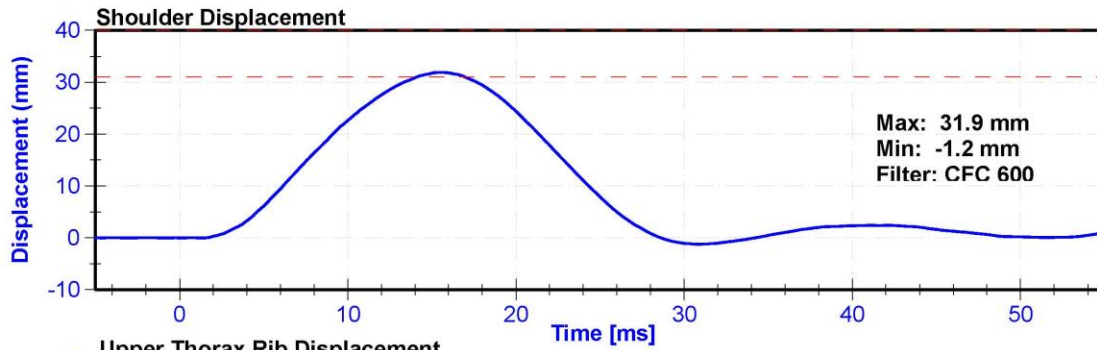

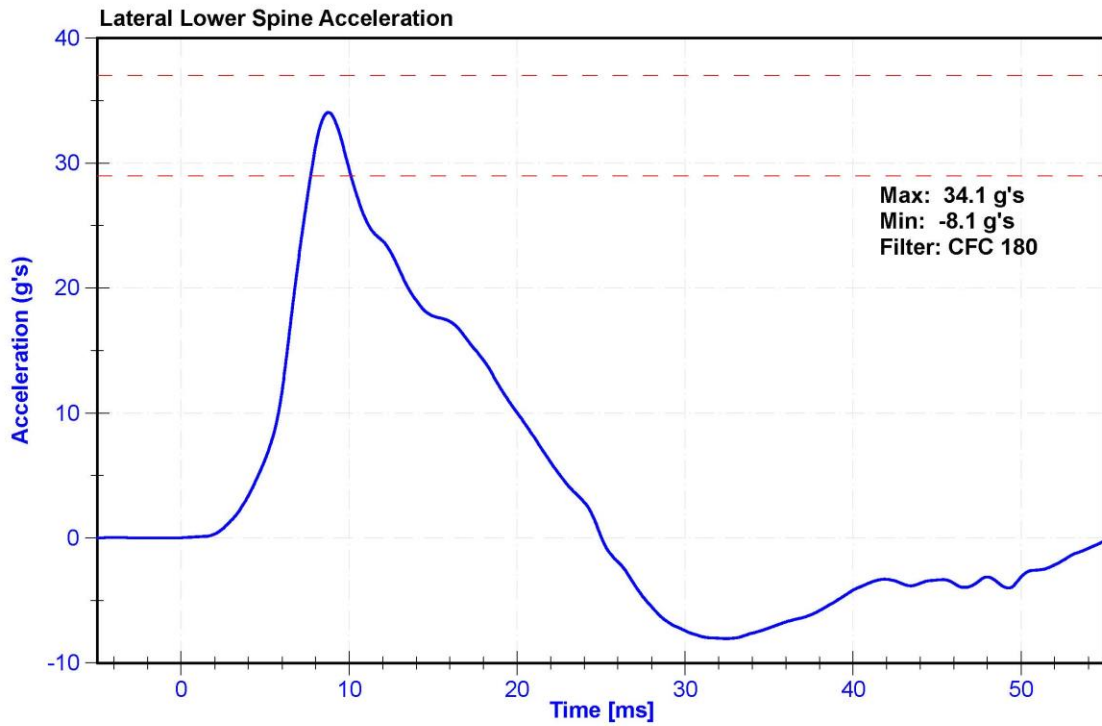
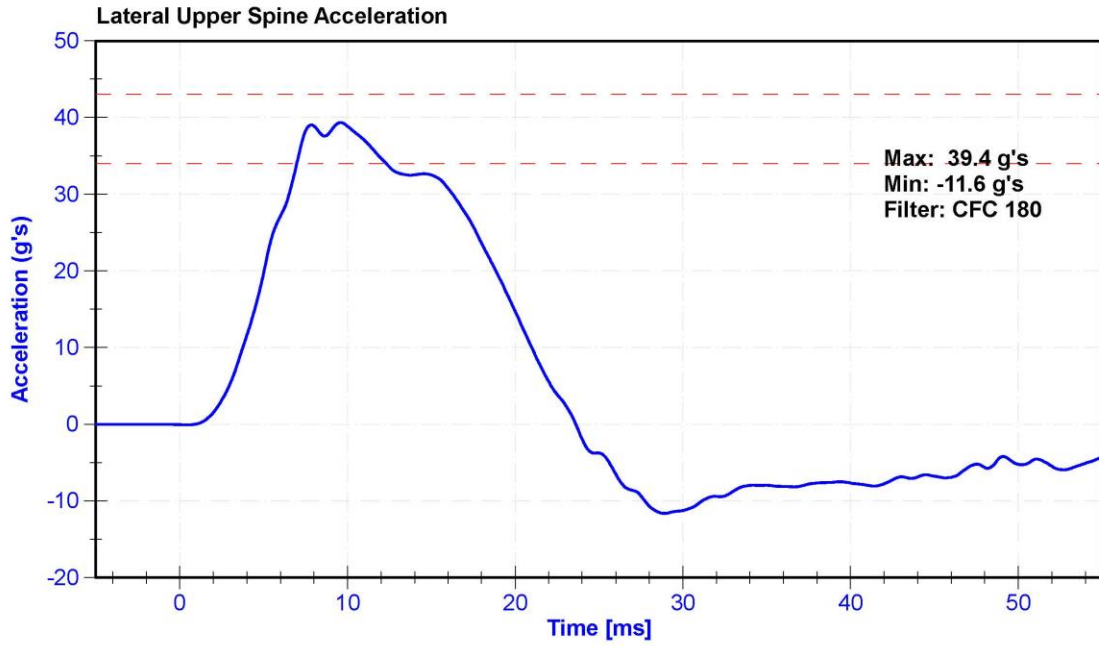

ATD Manufacturer	FTSS	Test Technician	D.Reinhard
ATD Serial Number	DG8012	Laboratory Supervisor	K. Brogan

Results

Test Parameter	Minimum Specification	Maximum Specification	Unit	Result	Pass/Fail
Temperature	20.6	22.2	°C	20.7	Pass
Humidity	10	70	%	60	Pass
Velocity	4.2	4.4	m/s	4.27	Pass
Probe Acceleration	14	18	g's	15.9	Pass
Lateral Upper Spine Acceleration	13	17	g's	14.9	Pass
Lateral Lower Spine Acceleration	7	11	g's	8.8	Pass
Upper Thorax Rib Deflection	32	40	mm	34.8	Pass
Middle Thorax Rib Deflection	39	45	mm	42.0	Pass
Lower Thorax Rib Deflection	35	43	mm	41.3	Pass

Transducer Calibrations

Channel	Manufacturer	Serial Number	Calibration Date	Calibration Due Date
Pendulum Accelerometer	MSI 64C-2000	A286228	1/29/2020	1/28/2021
Upper Spine Y Accelerometer	ENDEVCO 7264CT	AC-P64148	4/16/2020	10/15/2020
Lower Spine Y Accelerometer	ENDEVCO 7264C	AC-P51327	4/16/2020	10/15/2020
Upper Thorax Rib Potentiometer	Servo 1246	DS-2165GFE	5/6/2020	11/4/2020
Middle Thorax Rib Potentiometer	Servo 08TC1-3621	DS-45 GFE	5/6/2020	11/4/2020
Lower Thorax Rib Potentiometer	Servo 08TC1-3787	DS-011GFE	5/6/2020	11/4/2020

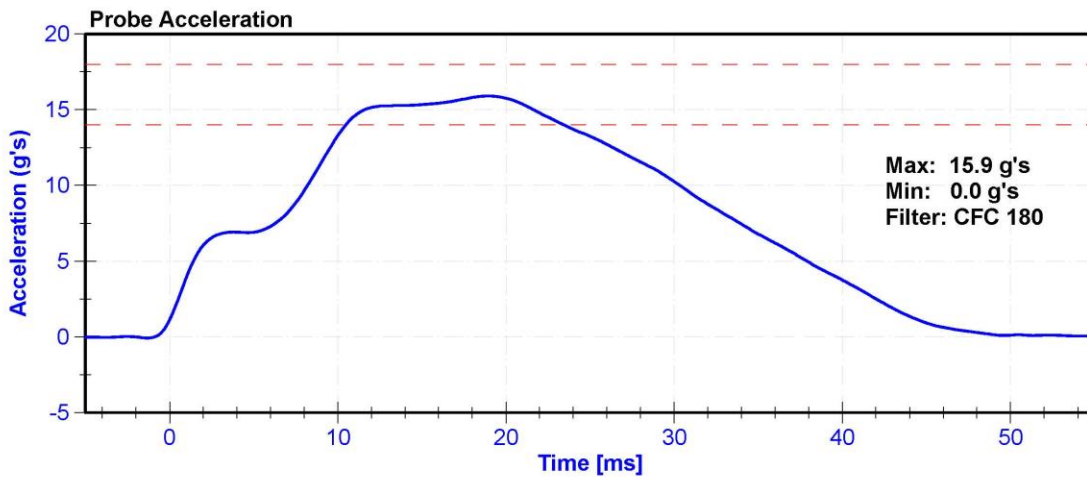

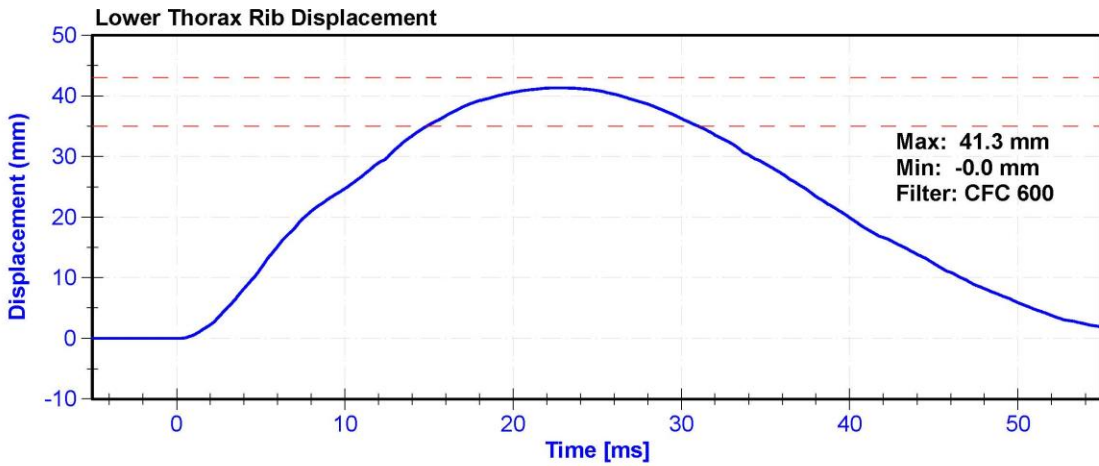
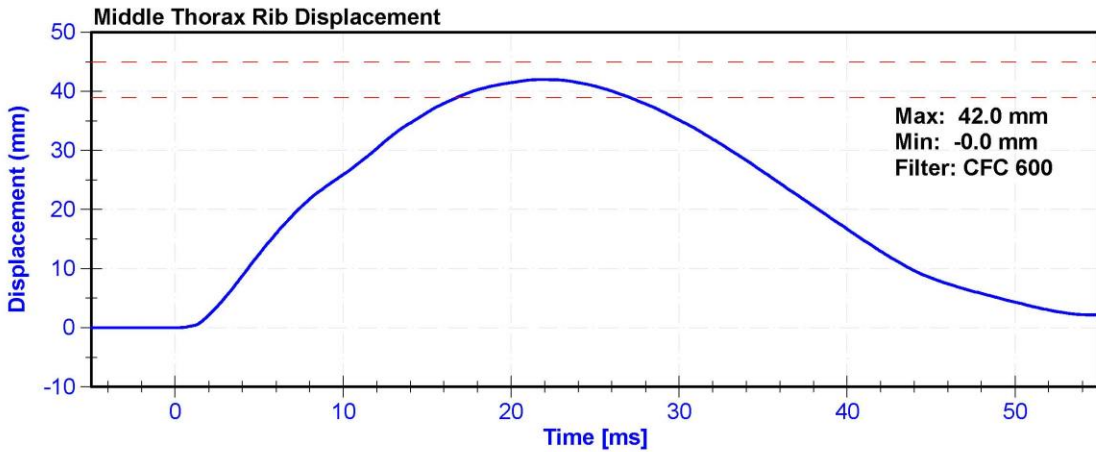
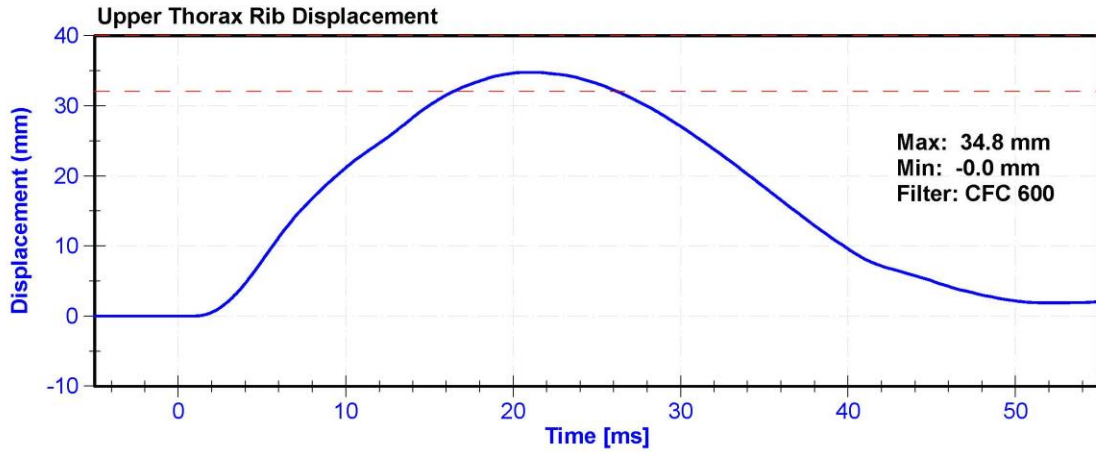

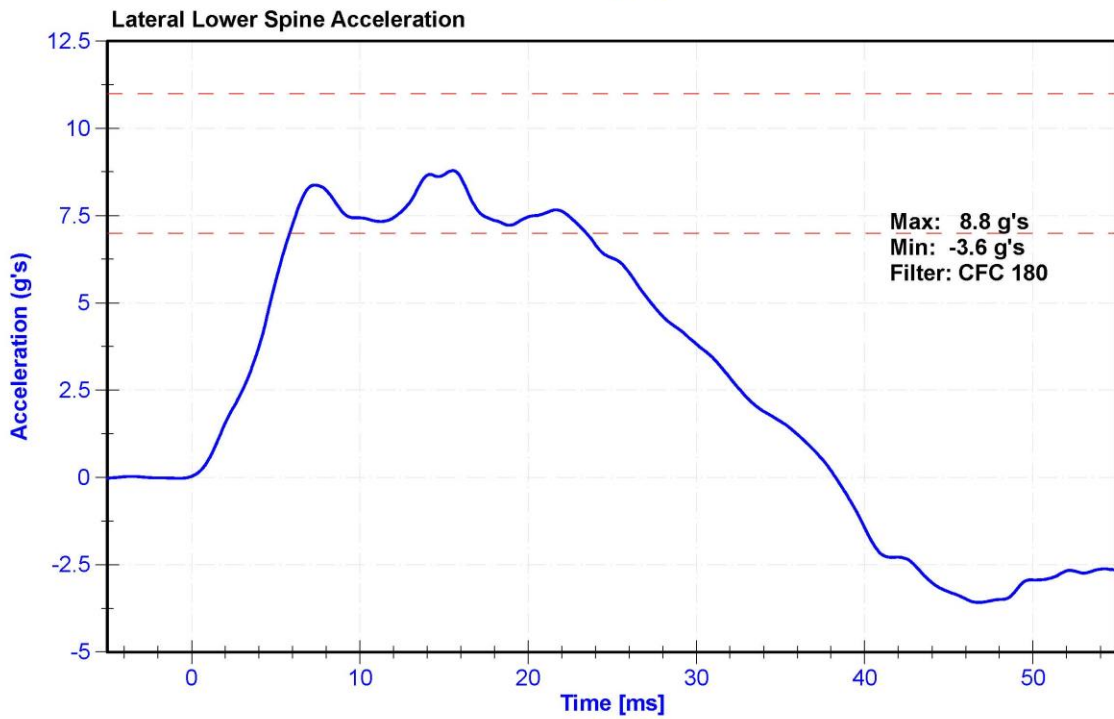
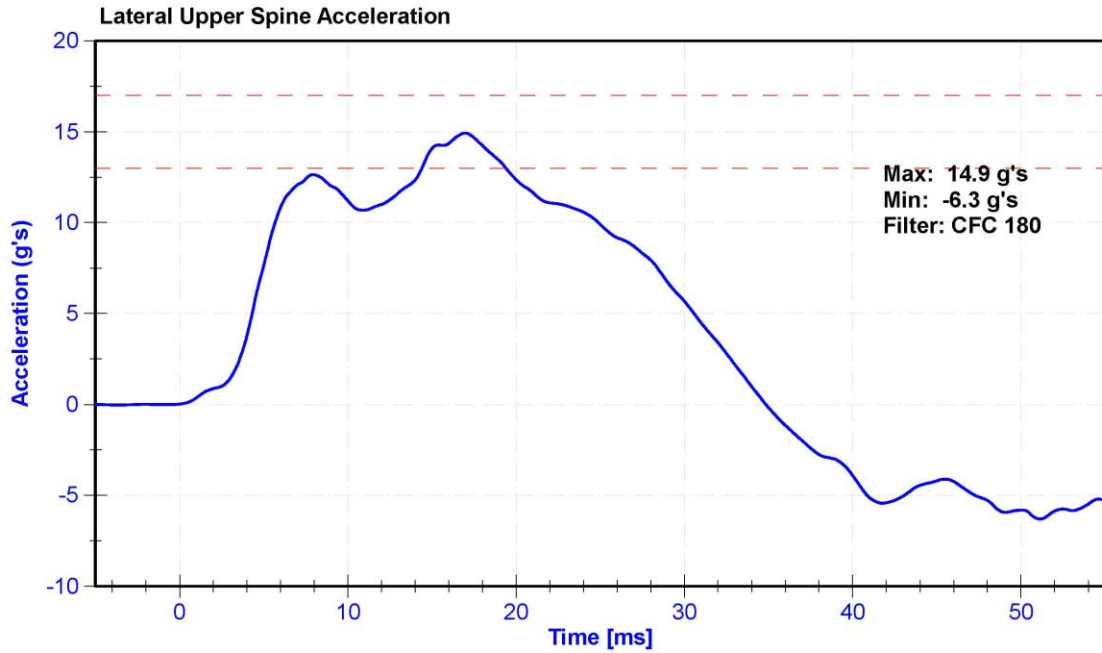

ATD Manufacturer	FTSS	Test Technician	D,Reinhard
ATD Serial Number	DG8012	Laboratory Supervisor	K. Brogan

Results

Test Parameter	Minimum Specification	Maximum Specification	Unit	Result	Pass/Fail
Temperature	20.6	22.2	°C	20.8	Pass
Humidity	10	70	%	57.0	Pass
Velocity	4.2	4.4	m/s	4.28	Pass
Probe Acceleration	12	16	g's	14.8	Pass
Lateral Lower Spine Acceleration	9	14	g's	10.7	Pass
Upper Abdomen Rib Deflection	36	47	mm	41.8	Pass
Lower Abdomen Rib Deflection	33	44	mm	40.0	Pass

Transducer Calibrations

Channel	Manufacturer	Serial Number	Calibration Date	Calibration Due Date
Probe Accelerometer	MSI 64C-2000	A286228	1/29/2020	1/28/2021
Lower Spine Y Accelerometer	ENDEVCO 7264C	AC-P51327	4/16/2020	10/15/2020
Upper Abdomen Rib Potentiometer	Servo 08TC1-3725	DS-008GFE	5/6/2020	11/4/2020
Lower Abdomen Rib Potentiometer	Servo 08TC1-3745	DS-1774GFE	5/6/2020	11/4/2020

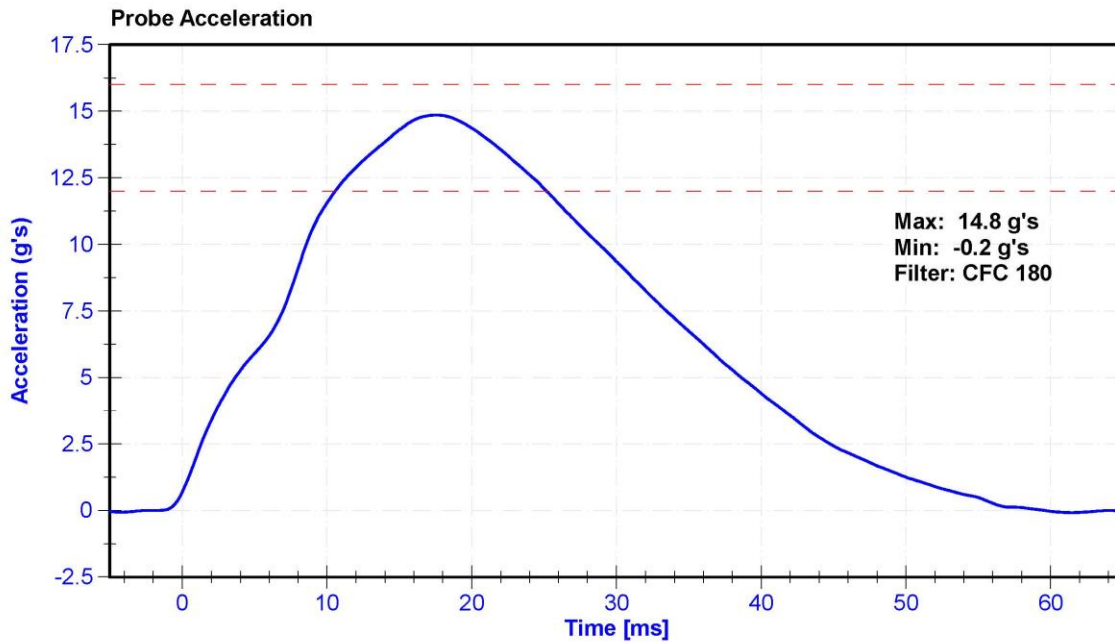

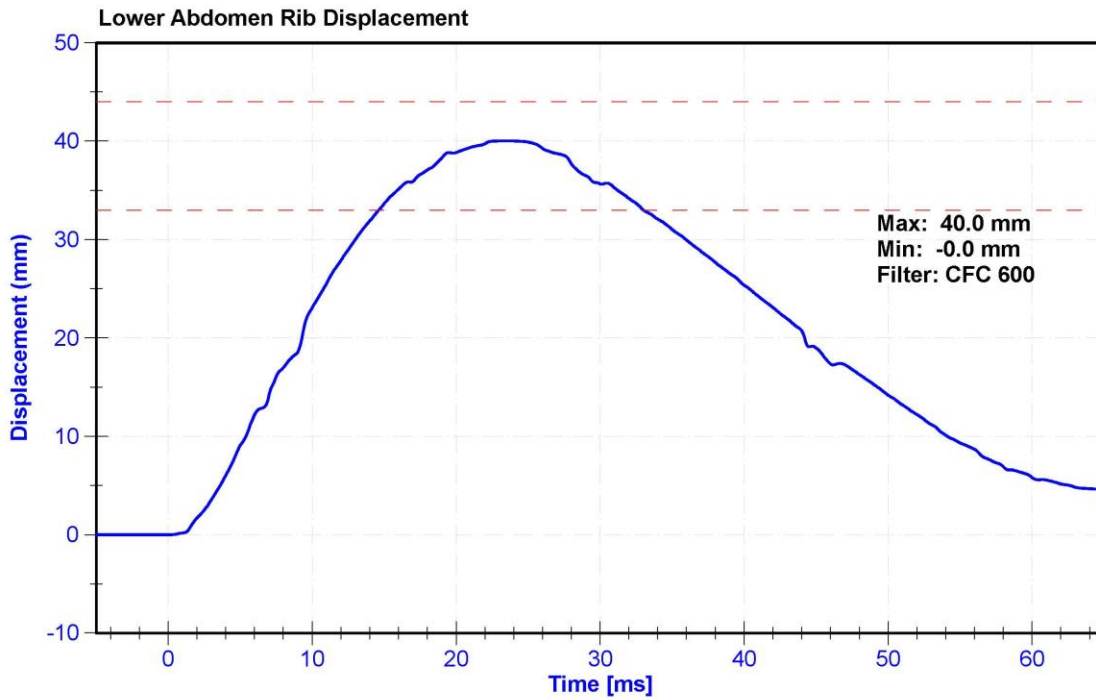
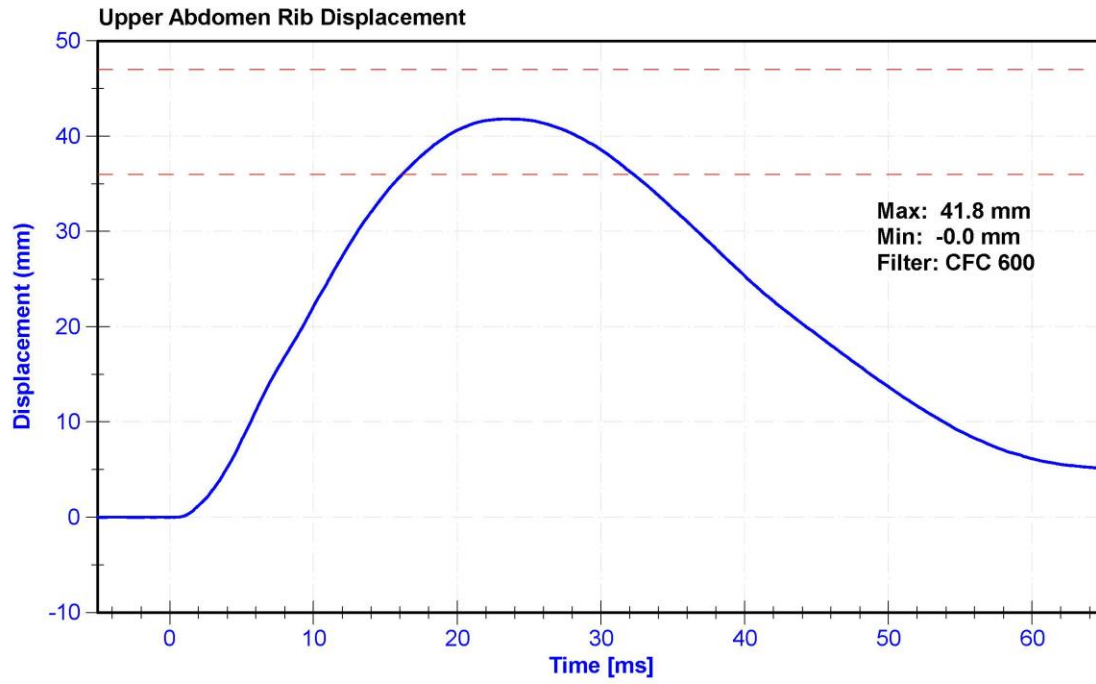

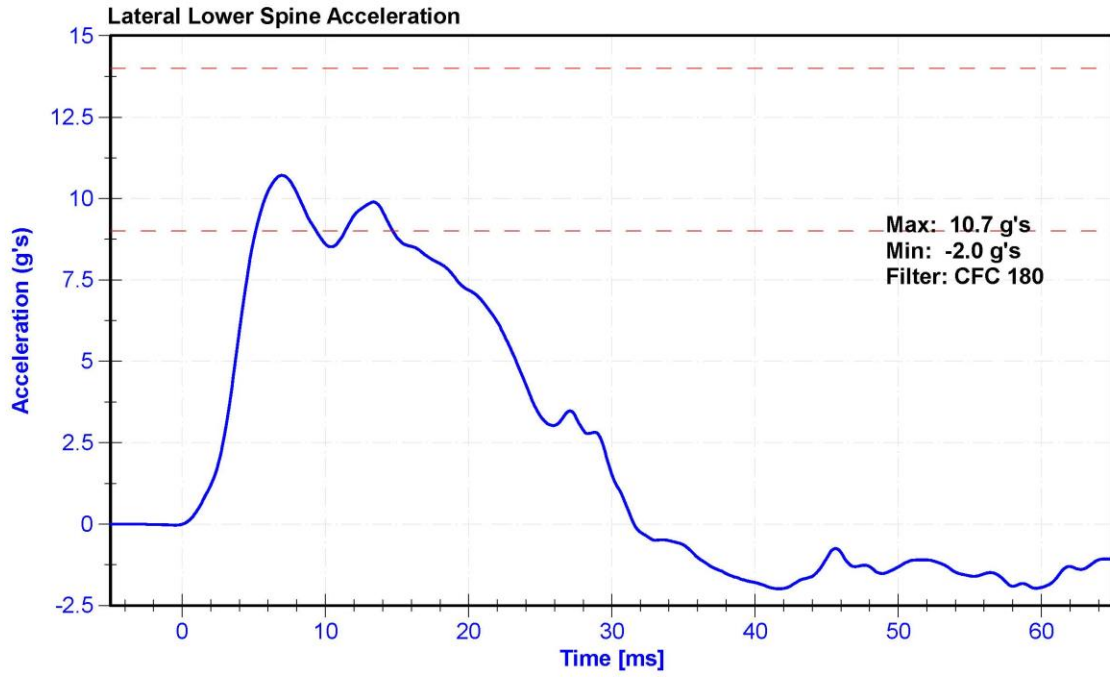

ATD Manufacturer	FTSS	Test Technician	D.Reinhard
ATD Serial Number	DG8012	Laboratory Supervisor	K. Brogan

Results

Test Parameter	Minimum Specification	Maximum Specification	Unit	Result	Pass/Fail
Temperature	20.6	22.2	°C	20.8	Pass
Humidity	10	70	%	53	Pass
Velocity	6.6	6.8	m/s	6.64	Pass
Probe Acceleration	38	47	g's	46.4	Pass
Lateral Pelvis Acceleration after 6ms	34	42	g's	41.4	Pass
Acetabulum Force	3600	4300	N	3932.5	Pass

Transducer Calibrations

Channel	Manufacturer	Serial Number	Calibration Date	Calibration Due Date
Pendulum Accelerometer	MSI 64C-2000	A286228	1/29/2020	1/28/2021
Pelvis Y Accelerometer	ENDEVCO 7264C	AC-P51875	4/16/2020	10/15/2020
Acetabulum Load Cell	Denton 3249J	LC-267Fy	3/19/2020	3/19/2021
Certification Plug	SACO	13535	9/23/2019	N/A
Crash Test Plug	SACO	13491	9/23/2019	N/A

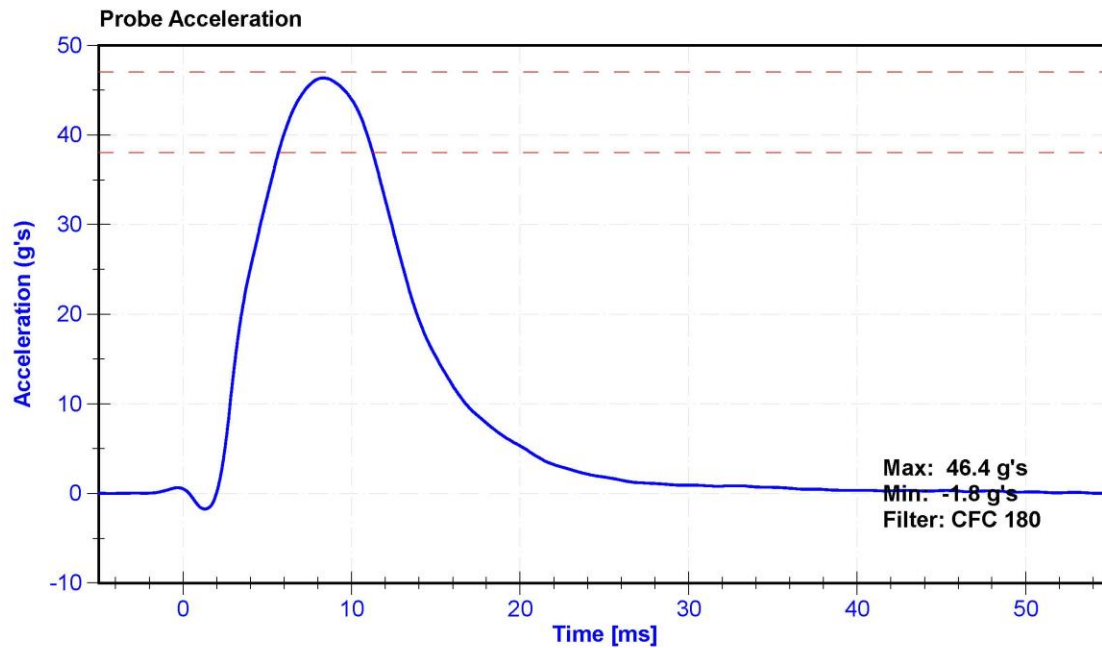

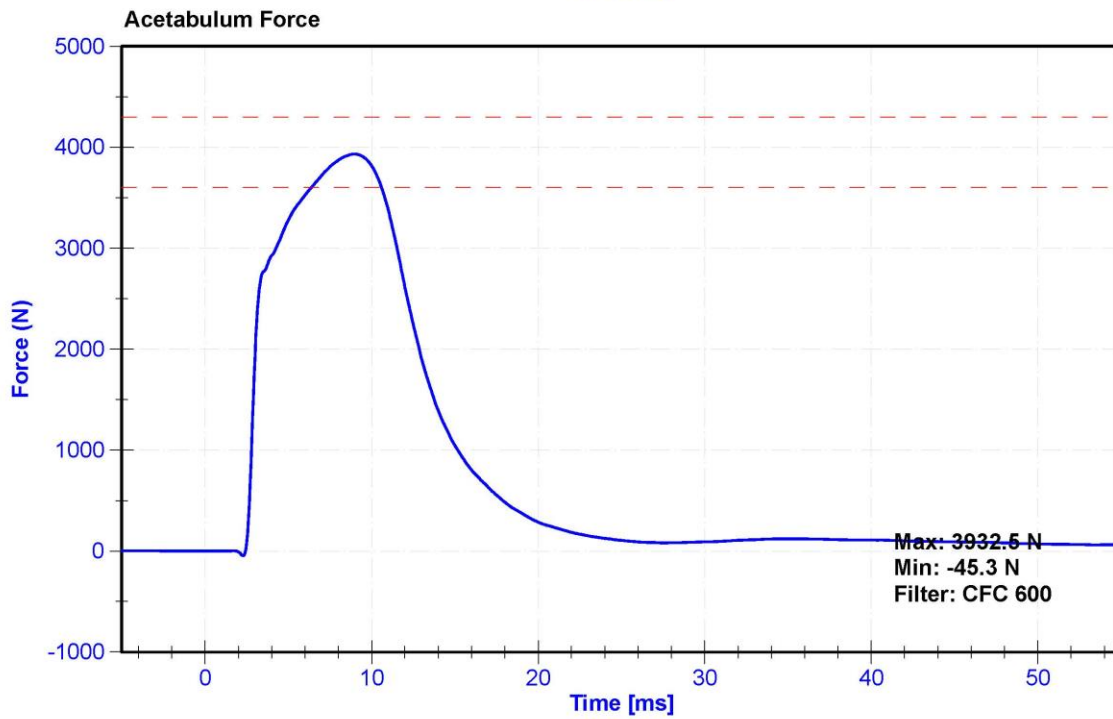
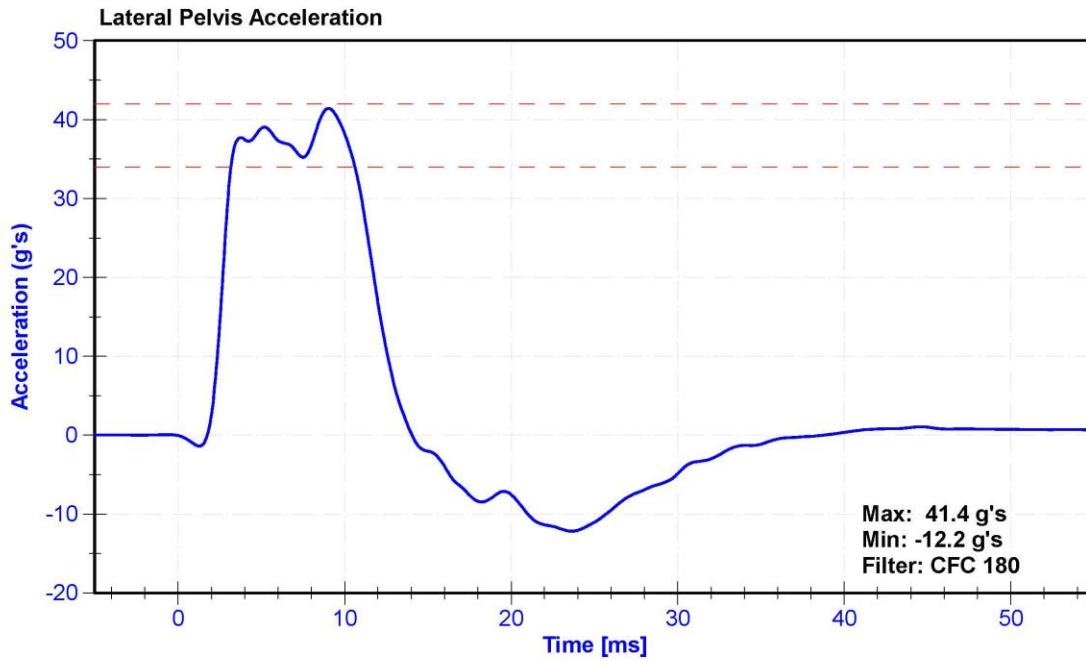



*DC&012
certfy
8/26/2019*

SID-11s Pelvis Plug Certification Test

Plug S/N 13535

Test Number 11179

Report Number 11217

Test Date 9/23/2019 11:46:15 AM

Force (-N) vs Extension (-mm)

	Test Results	Spec Min	Spec Max
Force @ 0.5 mm (N)	311.73	50.00	600.00
Force @ 1.5 mm (N)	1,262.64	850.00	1,400.00
Force @ 2.5 mm (N)	1,500.02	1,306.00	1,618.00
Force @ 3.0 mm (N)	1,532.24	1,361.00	1,673.00

Testing Machine STM-20 596554;
 Load Cell S/N (F1360947), Units (LBS) 1000
 Crosshead Speed (mm / min) or Rate 12.7
 Extension or Position Measured by XHD_100 (XHD100)

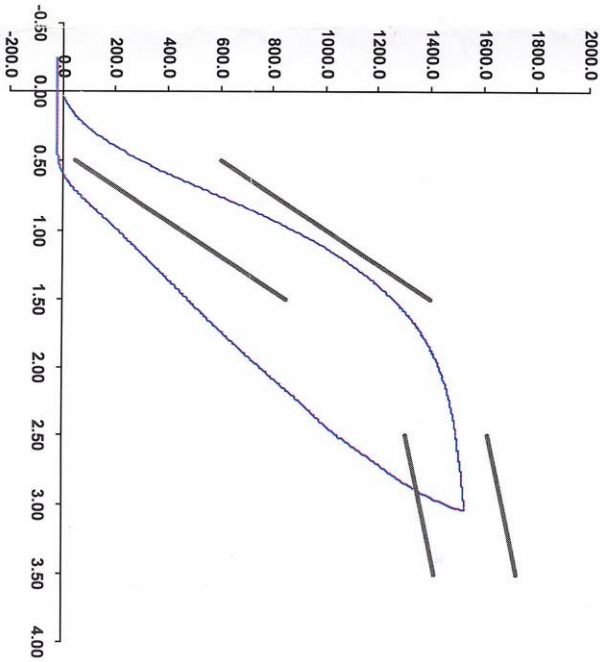

Operator

Part Number 180-4450

Template No 107 23-Sep-19
 SACO Research

By: DC Date: 9/23/2019
 SACO Research 41735 Elm St, #401 Murrieta, CA 92562 Tel 310-694-2082 FAX



SID-IIs Pelvis Plug Certification Test

Plug S/N 13491
 Test Number 11134
 Report Number 11172
 Test Date 9/23/2019 8:37:46 AM

	Test Results	Spec Min	Spec Max
Force @ 0.5 mm (N)	296.04	50.00	600.00
Force @ 1.5 mm (N)	1,260.30	850.00	1,400.00
Force @ 2.5 mm (N)	1,516.15	1,306.00	1,618.00
Force @ 3.0 mm (N)	1,549.27	1,361.00	1,673.00

Testing Machine STM-20 5965542
 Load Cell S/N (F1360947), Units (LBS) 1000
 Crosshead Speed (mm / min) or Rate 12.7
 Extension or Position Measured by XHD_100 (XHD100)

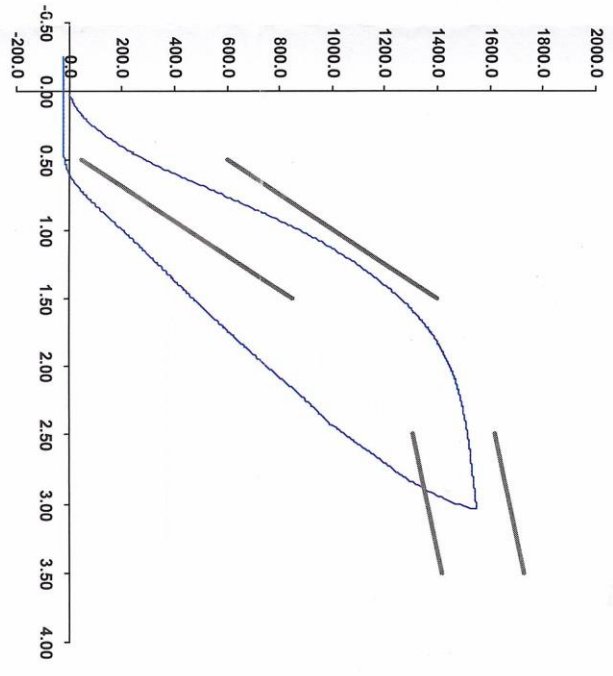

Operator _____
 Part Number 180-4450

Template No 107 23-Sep-19
 SACO Research

By: DC Date: 9/23/2019
 SACO Research 41735 Elm St, #401 Murrieta, CA 92562 Tel 310-694-2082 FAX

ATD Manufacturer	FTSS	Test Technician	D.Reinhard
ATD Serial Number	DG8012	Laboratory Supervisor	K. Brogan

Results

Test Parameter	Minimum Specification	Maximum Specification	Unit	Result	Pass/Fail
Temperature	20.6	22.2	°C	20.8	Pass
Humidity	10	70	%	53.0	Pass
Velocity	4.2	4.4	m/s	4.36	Pass
Probe Acceleration	36	45	g's	39.5	Pass
Lateral Pelvis Acceleration	28	39	g's	33.0	Pass
Iliac Force	4100	5100	N	4349.1	Pass

Transducer Calibrations

Channel	Manufacturer	Serial Number	Calibration Date	Calibration Due Date
Pendulum Accelerometer	MSI 64C-2000	A286228	1/29/2020	1/28/2021
Pelvis Y Accelerometer	ENDEVCO 7264C-2K	AC-P51875	4/16/2020	10/15/2020
Iliac Load Cell	DENTON 3228J	LC-290Fy	9/25/2019	9/24/2020

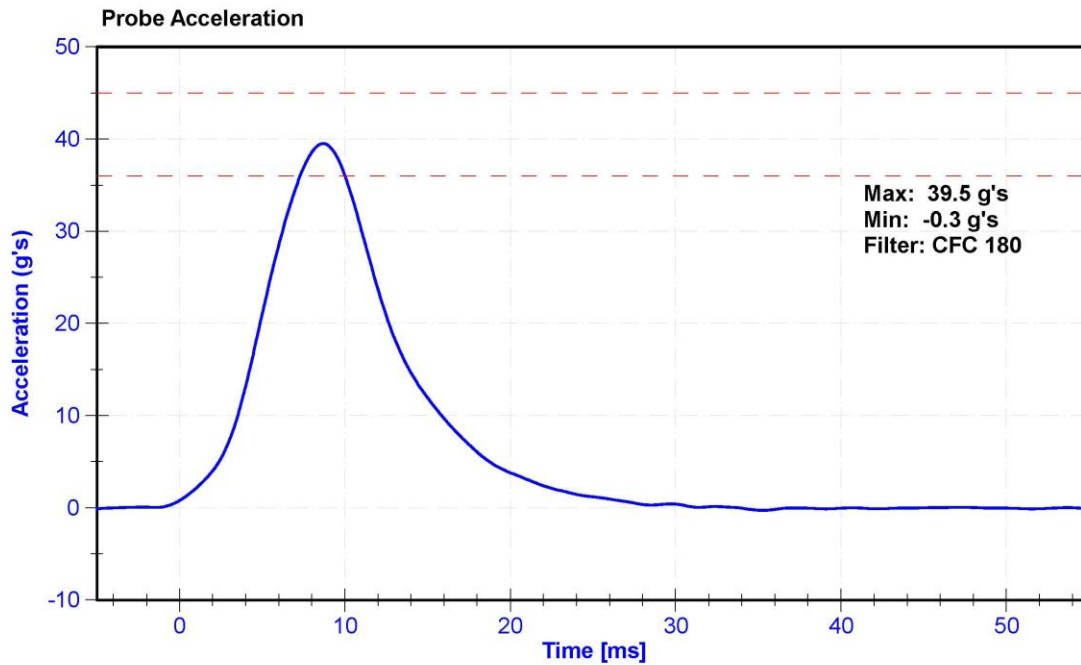

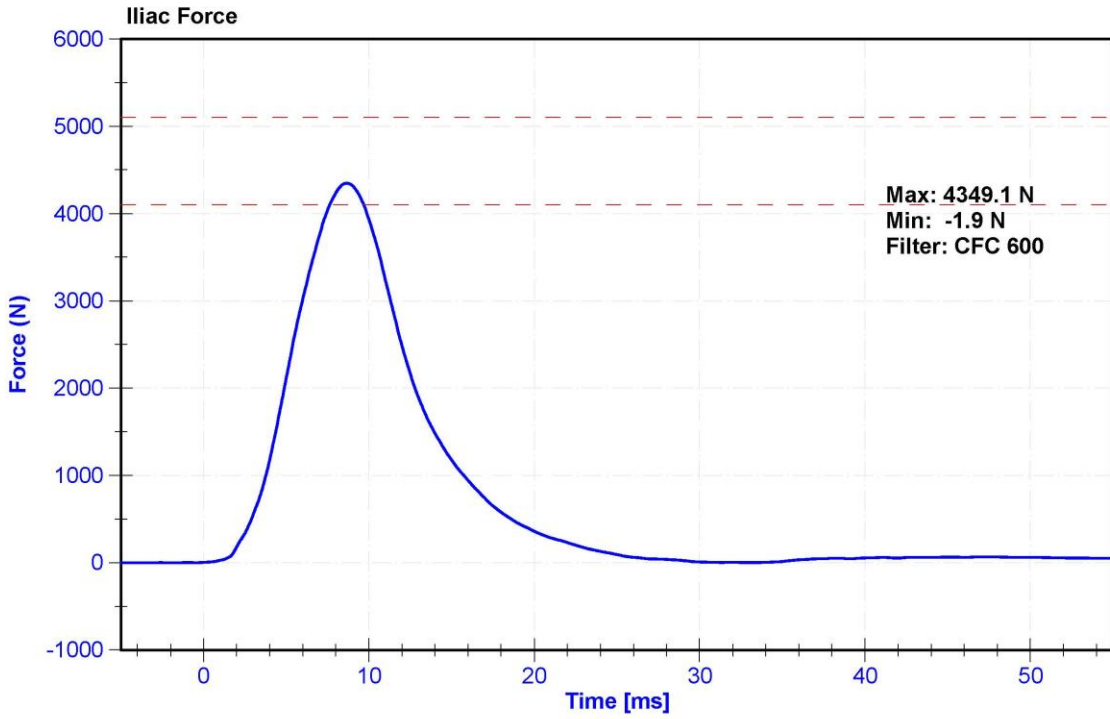
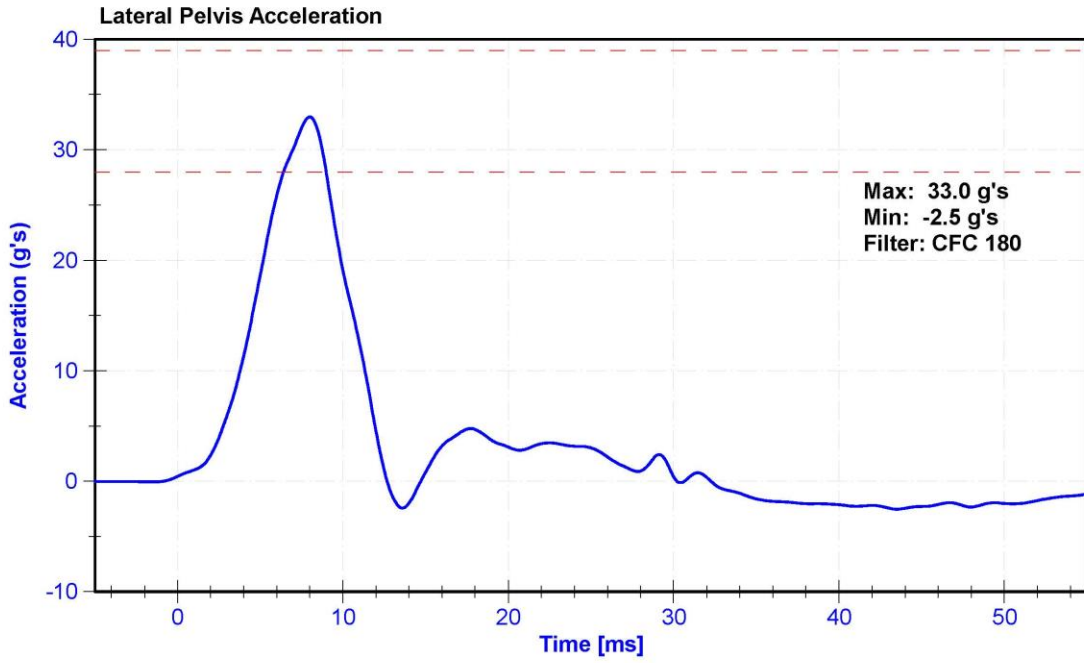

APPENDIX D

TEST EQUIPMENT AND INSTRUMENTATION CALIBRATION DATA

Table 1 – Dummy Instrumentation (SID-IIs)

				SID-IIs S/N: DG8012		
				Serial Number	Manufacturer	Calibration Date
Head Accelerometers		X	AC-P74788	ENDEVCO	4/16/2020	
		Y	AC-P83432	ENDEVCO	4/16/2020	
		Z	AC-P83319	ENDEVCO	4/16/2020	
Head Accelerometers - Redundant		X	AC-P80334	ENDEVCO	4/16/2020	
		Y	AC-P52155	ENDEVCO	4/16/2020	
		Z	AC-P83322	ENDEVCO	4/16/2020	
Displacement Potentiometer	Shoulder		Y			
	Thoracic Rib	Upper	Y	DS-2165GFE	Servo	5/6/2020
		Middle	Y	DS-45 GFE	Servo	5/6/2020
		Lower	Y	DS-011GFE	Servo	5/6/2020
	Abdominal Rib	Upper	Y	DS-008GFE	Servo	5/6/2020
		Lower	Y	DS-1774GFE	Servo	5/6/2020
Lower Spine Accelerometers (T12)		X	AC-P71272	ENDEVCO	5/19/2020	
		Y	AC-P51327	ENDEVCO	4/16/2020	
		Z	AC-P52067	ENDEVCO	4/16/2020	
Acetabulum Load Cell		Y	LC-267Fy	Denton	3/19/2020	
Lilac Wing Load Cell		Y	LC-290Fy	Denton	9/25/2019	
Pelvis Plug (Struck Side)			13224	SACO	8/12/2019	
Pelvis Plug (Non-Struck Side)						

Table 2 – Vehicle Instrumentation

Vehicle Instrumentation		Serial Number	Manufacturer	Calibration Date
Vehicle Center of Gravity	X	A255876	MSI 1201-1000	8/6/2020
Vehicle Center of Gravity	Y	A280828	MSI 1201-1000	8/6/2020
Vehicle Center of Gravity	Z	A281024	MSI 1201-1000	3/24/2020
Left Floor Sill	Y	A315872	MSI 1201-1000	3/31/2020
A-Pillar Sill	Y	A315020	MSI 1201-1000	6/18/2020
A-Pillar Low	Y	A315934	MSI 1201-1000	3/11/2020
A-Pillar Mid	Y	A315106	MSI 1201-1000	3/31/2020
B-Pillar Sill	Y	A315996	MSI 1201-1000	6/18/2020
B-Pillar Low	Y	A315197	MSI 1201-1000	3/7/2020
B-Pillar Mid	Y	A315798	MSI 1201-1000	3/31/2020
Driver Seat	Y	A315930	MSI 1201-1000	3/31/2020
Engine Top	X	A315080	MSI 1201-1000	3/30/2020
Engine Top	Y	A315785	MSI 1201-1000	3/30/2020
Firewall	Y	A250383	MSI 1201-1000	3/25/2020
Right Roof	Y	A255995	MSI 1201-1000	8/13/2020
Right Floor Sill	Y	A315825	MSI 1201-1000	3/18/2020
Rear Floorpan	X	A280195	MSI 1201-1000	3/26/2020
Rear Floorpan	Y	A280355	MSI 1201-1000	3/27/2020

Table 3 – Pole Instrumentation

Pole Instrumentation	Serial Number	Manufacturer	Calibration Date
Load Cell 1	1220AF-1117012-F0	Interface	10/16/2019
Load Cell 2	1220AF-1117023-F0	Interface	10/25/2019
Load Cell 3	1220AF-1117025-F0	Interface	10/25/2019
Load Cell 4	1220AF-1117019-F0	Interface	10/25/2019
Load Cell 5	1220AF-1117011-F0	Interface	10/25/2019
Load Cell 6	1220AF-1117017-F0	Interface	10/25/2019
Load Cell 7	1220AF-1117035-F0	Interface	10/25/2019
Load Cell 8	1220AF-1117006-F0	Interface	10/7/2019