

**NEW CAR ASSESSMENT PROGRAM
LANE DEPARTURE WARNING CONFIRMATION TEST
NCAP-DRI-LDW-20-15**

2020 Nissan Altima

DYNAMIC RESEARCH, INC.
355 Van Ness Avenue, STE 200
Torrance, California 90501



14 July 2020

Final Report

Prepared Under Contract No. DTNH22-14-D-00333

**U.S. DEPARTMENT OF TRANSPORTATION
National Highway Traffic Safety Administration
New Car Assessment Program
1200 New Jersey Avenue, SE
West Building, 4th Floor (NRM-110)
Washington, DC 20590**

Prepared for the Department of Transportation, National Highway Traffic Safety Administration, under Contract No. DTNH22-14-D-00333.

This publication is distributed by the U.S. Department of Transportation, National Highway Traffic Safety Administration, in the interest of information exchange. The opinions, findings, and conclusions expressed in this publication are those of the author(s) and not necessarily those of the Department of Transportation or the National Highway Traffic Safety Administration. The United States Government assumes no liability for its contents or use thereof. If trade or manufacturer's names or products are mentioned, it is only because they are considered essential to the object of the publication and should not be construed as an endorsement. The United States Government does not endorse products of manufacturers.

Prepared By: J. Lenkeit and A. Ricci

Program Manager

Test Engineer

Date: 14 July 2020

1. Report No. NCAP-DRI-LDW-20-15	2. Government Accession No.	3. Recipient's Catalog No.	
4. Title and Subtitle Final Report of Lane Departure Warning Confirmation Test of a 2020 Nissan Altima.		5. Report Date 14 July 2020	
		6. Performing Organization Code DRI	
7. Author(s) J. Lenkeit, Program Manager A. Ricci, Test Engineer		8. Performing Organization Report No. DRI-TM-19-203	
9. Performing Organization Name and Address Dynamic Research, Inc. 355 Van Ness Ave, STE 200 Torrance, CA 90501		10. Work Unit No.	
		11. Contract or Grant No. DTNH22-14-D-00333	
12. Sponsoring Agency Name and Address U.S. Department of Transportation National Highway Traffic Safety Administration New Car Assessment Program 1200 New Jersey Avenue, SE, West Building, 4th Floor (NRM-110) Washington, DC 20590		13. Type of Report and Period Covered Final Test Report February - March 2020	
		14. Sponsoring Agency Code NRM-110	
15. Supplementary Notes			
16. Abstract These tests were conducted on the subject 2020 Nissan Altima in accordance with the specifications of the New Car Assessment Program's (NCAP) most current Test Procedure in docket NHTSA-2006-26555-0135 to confirm the performance of a Lane Departure Warning system. The vehicle passed the requirements of the test for all three lane marking types and for both directions.			
17. Key Words Lane Departure Warning, LDW, New Car Assessment Program, NCAP		18. Distribution Statement Copies of this report are available from the following: NHTSA Technical Reference Division National Highway Traffic Safety Administration 1200 New Jersey Avenue, SE Washington, DC 20590	
19. Security Classif. (of this report) Unclassified	20. Security Classif. (of this page) Unclassified	21. No. of Pages 143	22. Price

TABLE OF CONTENTS

<u>SECTION</u>	<u>PAGE</u>
I. INTRODUCTION	1
II. DATA SHEETS	2
Data Sheet 1: Test Results Summary	3
Data Sheet 2: Vehicle Data	4
Data Sheet 3: Test Conditions	5
Data Sheet 4: Lane Departure Warning System Operation	7
III. TEST PROCEDURES	9
A. Test Procedure Overview	9
B. Lane Delineation Markings	10
C. Test Validity	12
D. Pass/Fail Criteria	13
E. Instrumentation	13
APPENDIX A Photographs	A-1
APPENDIX B Excerpts from Owner's Manual	B-1
APPENDIX C Run Logs	C-1
APPENDIX D Time Histories	D-1

Section I

INTRODUCTION

The purpose of the testing reported herein was to confirm the performance of a Lane Departure Warning (LDW) system installed on a 2020 Nissan Altima. The LDW system for this vehicle provides a both visual and tactile alerts. The vehicle passed the requirements of the test for all three lane marking types and for both directions.

The test procedure is described in detail in the National Highway Traffic Safety Administration (NHTSA) document "LANE DEPARTURE WARNING SYSTEM CONFIRMATION TEST" dated February of 2013 (Docket No. NHTSA-2006-26555-0135). Its purpose is to confirm the performance of LDW systems installed on light vehicles with gross vehicle weight ratings (GVWR) of up to 10,000 lbs. Current LDW technology relies on sensors to recognize a lane delimiting edge line. As such, the test procedures described in the document rely on painted lines, taped lines, or Botts Dots being present on the test course to emulate those found on public roadways. Although it is impossible to predict what technologies could be used by future LDW systems (e.g., magnetic markers, RADAR reflective striping, ultra violet paint, infrared, etc.), it is believed that minor modifications to these procedures, when deemed appropriate, could be used to accommodate the evaluation of alternative or more advanced LDW systems.

Section II
DATA SHEETS

LANE DEPARTURE WARNING
DATA SHEET 1: TEST RESULTS SUMMARY

(Page 1 of 1)

2020 Nissan Altima

VIN: 1N4BL4DV2LC1xxxx

Test Date: 2/11/2020

Lane Departure Warning setting: On

Test 1 – Continuous White Line Left: Pass Right: Pass

Test 2 – Dashed Yellow Line Left: Pass Right: Pass

Test 3 – Botts Dots Left: Pass Right: Pass

Overall: Pass

Notes:

LANE DEPARTURE WARNING
DATA SHEET 2: VEHICLE DATA

(Page 1 of 1)

2020 Nissan Altima

TEST VEHICLE INFORMATION

VIN: 1N4BL4DV2LC1xxxx

Body Style: Sedan

Color: Gun Metallic

Date Received: 2/3/2020

Odometer Reading: 22 mi

DATA FROM VEHICLE'S CERTIFICATON LABEL

Vehicle manufactured by: Nissan Motor Co., LTD

Date of manufacture: 10/19

Vehicle Type: Passenger Car

DATA FROM TIRE PLACARD

Tires size as stated on Tire Placard: Front: 215/55R17 94V

Rear: 215/55R17 94V

Recommended cold tire pressure: Front: 230 kPa (33 psi)

Rear: 230 kPa (33 psi)

TIRES

Tire manufacturer and model: Continental Procontact TX

Front tire size: 215/55R17 94V

Rear tire size: 215/55R17 94V

Front tire DOT prefix: VY3R WCN5

Rear tire DOT prefix: VY3R WCN5

LANE DEPARTURE WARNING
DATA SHEET 3: TEST CONDITIONS

(Page 1 of 2)

2020 Nissan Altima

GENERAL INFORMATION

Test date: 2/11/2020

AMBIENT CONDITIONS

Air temperature: 16.7 C (62 F)

Wind speed: 1.5 m/s (3.5 mph)

- X Wind speed ≤ 10 m/s (22 mph)
- X Tests were not performed during periods of inclement weather. This includes, but is not limited to, rain, snow, hail, fog, smoke, or ash.
- X Tests were conducted during daylight hours with good atmospheric visibility (defined as an absence of fog and the ability to see clearly for more than 5000 meters). The tests were not conducted with the vehicle oriented into the sun during very low sun angle conditions, where the sun is oriented 15 degrees or less from horizontal, and camera "washout" or system inoperability results.

VEHICLE PREPARATION

Verify the following:

All non-consumable fluids at 100% capacity: X

Fuel tank is full: X

Tire pressures are set to manufacturer's recommended cold tire pressure: X

Front: 230 kPa (33 psi)

Rear: 230 kPa (33 psi)

LANE DEPARTURE WARNING
DATA SHEET 3: TEST CONDITIONS

(Page 2 of 2)

2020 Nissan Altima

WEIGHT

Weight of vehicle as tested including driver and instrumentation

Left Front: 490.3 kg (1081 lb)

Right Front: 469.5 kg (1035 lb)

Left Rear: 344.7 kg (760 lb)

Right Rear: 316.2 kg (697 lb)

Total: 1620.7 kg (3573 lb)

LANE DEPARTURE WARNING
DATA SHEET 4: LANE DEPARTURE WARNING SYSTEM OPERATION

(Page 1 of 3)

2020 Nissan Altima

Name of the LDW option, option package, etc.:

Lane Departure Warning

Type and location of sensor(s) used:

Camera located behind the windshield above the rearview mirror.

Lane Departure Warning Setting used in test: On

How is the Lane Departure Warning presented to the driver? Warning light
 Buzzer or audible alarm

(Check all that apply)

Vibration

Other _____

Describe the method by which the driver is alerted. For example, if the warning is a light, where is it located, its color, size, words or symbol, does it flash on and off, etc. If it is a sound, describe if it is a constant beep or a repeated beep. If it is a vibration, describe where it is felt (e.g., pedals, steering wheel), the dominant frequency, (and possibly magnitude), the type of warning (light, audible, vibration, or combination), etc.

The visual alert is displayed in the center instrument cluster between the speedometer and tachometer. It shows a rear outline of a vehicle between two lanes. When the vehicle approaches either the left or the right side of the traveling lane, the lane line on the LDW visual indicator panel will blink on the side of the potential departure and the steering wheel will vibrate. The warning function will stop when the vehicle returns inside of the lane markers. See Appendix A, Figure A12.

LANE DEPARTURE WARNING
DATA SHEET 4: LANE DEPARTURE WARNING SYSTEM OPERATION

(Page 2 of 3)

2020 Nissan Altima

Is the vehicle equipped with a switch whose purpose is to render LDW inoperable? Yes
 No

If yes, please provide a full description including the switch location and method of operation, any associated instrument panel indicator, etc.

Controls on the left side of the steering wheel are used to access the system menus. The hierarchy is:

Settings

Driver Assistance

Lane

Lane Departure Warning - select On or Off

See Appendix A, Figure A11.

Is the vehicle equipped with a control whose purpose is to adjust the range setting or otherwise influence the operation of LDW? Yes
 No

If yes, please provide a full description.

Are there other driving modes or conditions that render LDW inoperable or reduce its effectiveness? Yes
 No

If yes, please provide a full description.

System limitations are described on pages 5-36 to 5-38 of the Owner's Manual. These pages are reproduced on pages B-24 to B-26 of Appendix B.

Notes:

Section III

TEST PROCEDURES

A. Test Procedure Overview

Each LDW test involved one of three lane marking types: solid white lines, dashed yellow lines, or Botts Dots. Lane departures were done both to the left and to the right, and each test condition was repeated five times, as shown in Table 1.

Table 1. LDW Test Matrix

Lane Geometry	Line Type	Departure Direction	Number of Trials
Straight	Solid	L	5
		R	5
	Dashed	L	5
		R	5
	Botts Dots	L	5
		R	5

Prior to the start of a test series involving a given lane marking type and departure direction combination, the accuracy of the distance to lane marking measurement was verified. This was accomplished by driving the vehicle to the approximate location at which the lane departure would occur and placing the tire at the lane marking edge of interest (i.e., distance to lane marking = 0). The real-time display of distance to the lane marking was then observed to verify that the measured distance was within the tolerance (5 cm). If the measured distance was found to be greater than the tolerance, the instrumentation setup was checked and corrected, if necessary. If the measured distance was found to be within the tolerance, the instrumentation setup was considered appropriate and the test series was begun.

To begin the maneuver, the vehicle was accelerated from rest to a test speed of 72.4 km/h (45 mph), while being driven in a straight line parallel to the lane marking of interest, with the centerline of the vehicle approximately 1.83 m (6.0 ft) from the lane edge (i.e., such that the vehicle would pass through the center of the start gate). The test speed was achieved at least 60 m (200 ft) before the start gate was reached. Striking any start gate cones was not permitted, and any run in which a cone was struck was considered to be invalid. Also, during the initialization and test phases, the test driver avoided using turn signals and avoided applying any sudden acceleration, sudden steering, or sudden braking, and any use of the turn signals, sudden acceleration, sudden steering, or sudden braking invalidated the test trial.

Data collection began with the vehicle at least 60 m (200 ft) from the start gate, which was configured using a pair of non-reflective, low-contrast color traffic cones. A second set of cones, placed 6 m (20 ft) longitudinally before the start gate, was used to guide the driver into the start gate. The lateral width between the cone pairs was 20 cm (8 in) greater than the width of the vehicle, and the centerline of each pair was laterally offset from the lane marking by 1.8 m (6 ft).

Once the driver passed the gate, the driver manually input sufficient steering to achieve a lane departure with a target lateral velocity of 0.5 m/s with respect to the lane line. As shown in Figure 1, two additional non-reflective cones were used to guide the driver in making this steering maneuver. Throughout the maneuver, the driver modulated the throttle or used cruise control, as appropriate, such that vehicle speed remained at constant speed. The test was considered complete when the vehicle crossed at least 1 m (3.3 ft) over the lane edge boundary.

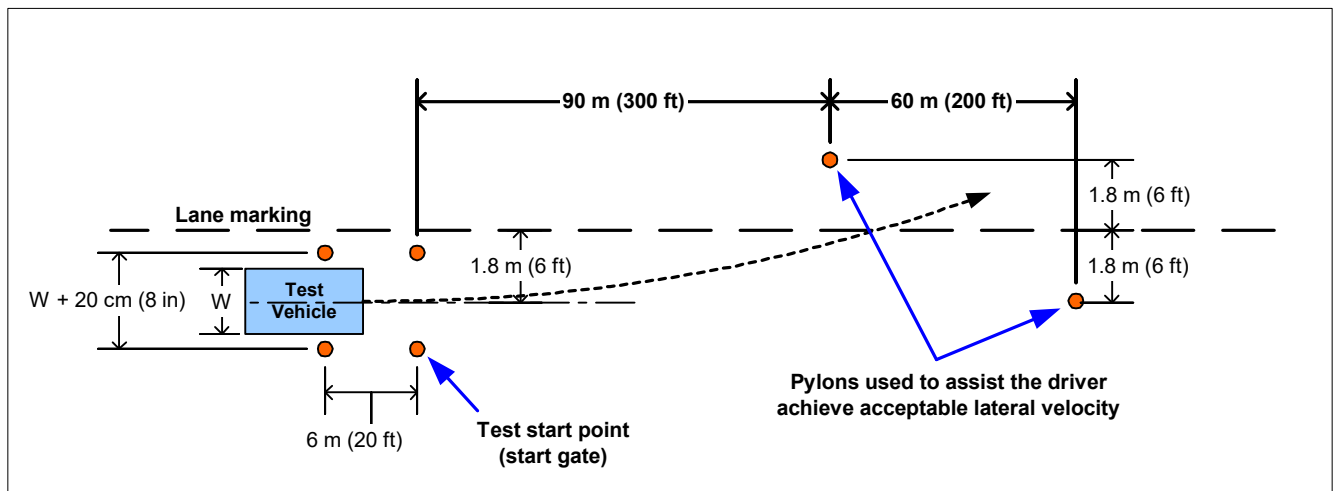

Figure 1. Position of Cones Used to Assist Driver

Data collected included vehicle speed, position, and yaw rate. In addition to cone strikes, vehicle speed and yaw rate data were used to identify invalid runs as described in Section C below. Data from trials where speed or yaw rate were outside of the performance specification were not considered valid.

B. Lane Delineation Markings

The New Car Assessment Program’s Test Procedure for the confirmation of a Lane Departure Warning system contains a requirement that all lane markings meet United States Department of Transportation (USDOT) specifications as described in the Manual on Uniform Traffic Control Devices (MUTCD) and be considered in “very good condition”.

1. Lane Marker Width

The width of the edge line marker was 10 to 15 cm (4 to 6 in). This is considered to be a normal width for longitudinal pavement markings under Section 3A.05 of the MUTCD.

2. Line Marking Color and Reflectivity

Lane marker color and reflectivity met all applicable standards. These standards include those from the International Commission of Illumination (CIE) for color and the American Society for Testing and Materials (ASTM) on lane marker reflectance.

3. Line Styles

The tests described in this document required the use of three lane line configurations: continuous solid white, discontinuous dashed yellow, and discontinuous with raised pavement markers.

- Continuous White Line

A continuous white line is defined as a white line that runs for the entire length of the test course.

- Dashed Yellow Line

As stated in the MUTCD, and as shown in Figure 2, a discontinuous dashed yellow line is defined as by a series of 3 m (10 ft) broken (dashed) yellow line segments, spaced 9.1 m (30 ft) apart.

- Raised Pavement Marker Line (Botts Dots)

California Standard Plans indicates raised pavement markers are commonly used in lieu of painted strips for marking roads in California. Other states, mainly in the southern part of the United States, rely on them as well. These markers may be white or yellow, depending on the specific application, following the same basic colors of their analogous white and yellow painted lines. Following the California 2006 Standard Plans, three types of raised pavement markings are used to form roadway lines. It is believed that these types of roadway markings are the hardest for an LDW sensor system to process. Type A and Type AY are non-reflective circular domes that are approximately 10 cm (4 in) in diameter and approximately 1.8 cm (0.7 in) high. Type C and D are square markings that are retro reflective in two directions measuring approximately 10 x 10 x 5 cm (4 x 4 x 0.5 in), and Type G and H that are the same as C and D only retro reflective in a single direction.

For the tests described in this document, raised pavement markers were set up following California Standard Plan A20A, Detail 4, as shown in Figure 3. Note that in this figure, the squares are Type D yellow reflectors and the circles are yellow Type AY discs.

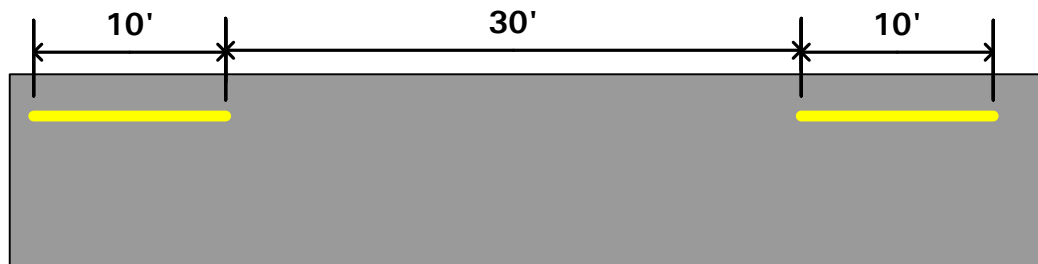

Figure 2. MUTCD Discontinuous Dashed Line Specifications

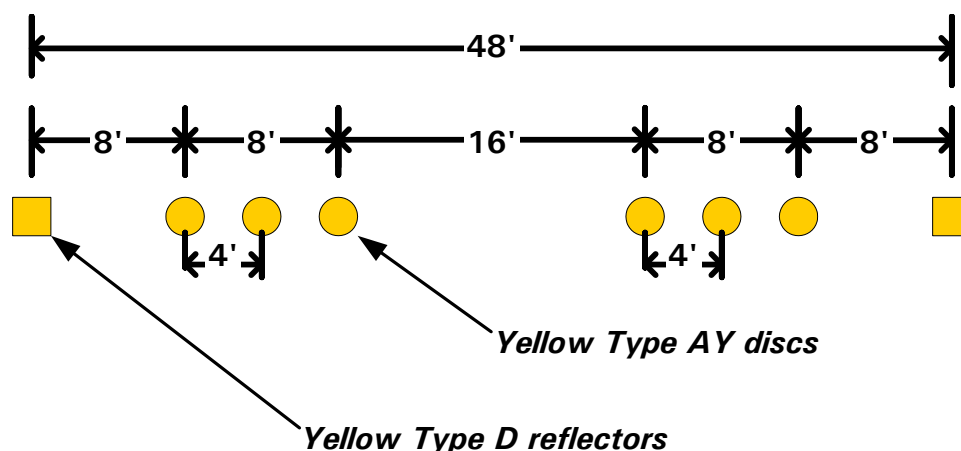

Figure 3. California Standard Plan A20A, Detail 4

C. Test Validity

1. Speed

All LDW tests were conducted at 72.4 km/h (45 mph). Test speed was monitored and a test was considered valid if the test speed remained within ± 2 km/h (± 1.2 mph) of the 72.4 km/h (45 mph) target speed. It was required that the speed must remain within this window from the start of the test until any part of the vehicle crossed a lane line by 1 m (3.3 ft) or more.

2. Lateral Velocity

All tests were conducted with a lateral velocity of 0.1 to 0.6 m/s (0.3 to 2.0 ft/s), measured with respect to the lane line at the time of the alert. To assist the test driver in being able to efficiently establish the target lateral velocity, cones were positioned in the manner shown in Figure 1.

3. Yaw Rate

It was required that the magnitude of the vehicle's yaw rate could not exceed 1.0 deg/sec at any time during lane departure maneuver, from the time the vehicle passes through the start gate to the instant the vehicle has crossed a lane line by 1 m (3.3 ft).

D. Pass/Fail Criteria

The measured test data were used to determine the pass/fail outcome for each trial. The outcome was based on whether the LDW produced an appropriate alert during the maneuver. In the context of this test procedure, a lane departure is said to occur when any part of the two-dimensional polygon used to represent the test vehicle breaches the inboard lane line edge (i.e., the edge of the line close to the vehicle before the departure occurs). In the case of tests performed in this procedure, the front corner of the polygon, defined as the intersection of the center of the front wheels (longitudinally) with the outboard edge of the front tire (laterally), crossed the line edge first. So, for example, if the vehicle departed its lane to the left, the left front corner of the polygon would first breach the lane line edge.

For an individual trial to be considered a "pass":

- Test speed, lateral velocity, and yaw rate validity conditions must be satisfied.
- The LDW alert must not occur when the lateral position of the vehicle is greater than 0.75 m (2.5 ft) from the lane line edge (i.e., prior to the lane departure).
- The LDW alert must occur before the lane departure exceeds 0.3 m (1.0 ft).

For an overall, "Pass" the LDW system must satisfy the pass criteria for 3 of 5 individual trials for each combination of departure direction and lane line type (60%), and pass 20 of the 30 trials overall (66%).

E. Instrumentation

Table 2 lists the sensors, signal conditioning, and data acquisition equipment used for these tests.

Table 2. Test Instrumentation and Equipment

Type	Output	Range	Accuracy, Other Primary Specs	Mfr, Model	Serial Number	Calibration Dates Last Due
Tire Pressure Gauge	Vehicle Tire Pressure	0-100 psi 0-690 kPa	0.5 psi 3.45 kPa	Ashcroft, D1005PS	17042707002	By: DRI Date: 7/3/2019 Due: 7/3/2020
Platform Scales	Vehicle Total, Wheel, and Axle Load	8000 lb 35.6 kN	±1.0% of applied load	Intercomp, SWII	1110M206352	By: DRI Date: 1/6/2020 Due: 1/6/2021
Differential Global Positioning System	Position, Velocity	Latitude: ±90 deg Longitude: ±180 deg Altitude: 0-18 km Velocity: 0-1000 knots	Horizontal Position: ±1 cm Vertical Position: ±2 cm Velocity: 0.05 km/h	Trimble GPS Receiver, 5700 (base station and in-vehicle)	00440100989	NA
Multi-Axis Inertial Sensing System	Position; Longitudinal, Lateral, and Vertical Accels; Lateral, Longitudinal and Vertical Velocities; Roll, Pitch, Yaw Rates; Roll, Pitch, Yaw Angles	Latitude: ±90 deg Longitude: ±180 deg Altitude: 0-18 km Velocity: 0-1000 knots Accel: ±100 m/s ² Angular Rate: ±100 deg/s Angular Disp: ±180 deg	Position: ±2 cm Velocity: 0.05 km/h Accel: ≤ 0.01% of full range Angular Rate: ≤ 0.01% of full range Roll/Pitch Angle: ±0.03 deg Heading Angle: ±0.1 deg	Oxford Technical Solutions (OXTS), Inertial+		By: Oxford Technical Solutions ¹ Date: Due:
Real-Time Calculation of Position and Velocity Relative to Lane Markings	Distance and velocity to lane markings	Lateral Lane Dist: ±30 m Lateral Lane Velocity: ±20 m/sec	Lateral Distance to Lane Marking: ±2 cm Lateral Velocity to Lane Marking: ±0.02m/sec	Oxford Technical Solutions (OXTS), RT-Range	97	NA

¹ Oxford Technical Solutions recommends calibration every two years.

Type	Output	Range	Accuracy, Other Primary Specs	Mfr, Model	Serial Number	Calibration Dates Last Due
Microphone	Sound (to measure time at alert)	Frequency Response: 80 Hz – 20 kHz	Signal-to-noise: 64 dB, 1 kHz at 1 Pa	Audio-Technica AT899	NA	NA
Light Sensor	Light intensity (to measure time at alert)	Spectral Bandwidth: 440-800 nm	Rise time < 10 msec	DRI designed and developed Light Sensor	NA	NA
Coordinate Measurement Machine	Inertial Sensing System Coordinates	0-8 ft 0-2.4 m	±.0020 in. ±.051 mm (Single point articulation accuracy)	Faro Arm, Fusion	UO8-05-08-06636	By: DRI Date: 1/6/2020 Due: 1/6/2021
Type	Description			Mfr, Model	Serial Number	
Data Acquisition System	Data acquisition is achieved using a dSPACE MicroAutoBox II Data from the Oxford IMU, including Longitudinal, Lateral, and Vertical Acceleration, Roll, Yaw, and Pitch Rate, Forward and Lateral Velocity, Roll and Pitch Angle are sent over Ethernet to the MicroAutoBox. The Oxford IMUs are calibrated per the manufacturer's recommended schedule (listed above).			D-Space Micro-Autobox II 1401/1513		
				Base Board	549068	
				I/O Board	588523	

For systems that implement audible or haptic alerts, part of the pre-test instrumentation verification process is to determine the tonal frequency of the audible warning or the vibration frequency of the tactile warning through use of the PSD (Power Spectral Density) function in Matlab. This is accomplished in order to identify the center frequency around which a band-pass filter is applied to subsequent audible or tactile warning data so that the beginning of such warnings can be programmatically determined. The band-pass filter used for these warning signal types is a phaseless, forward-reverse pass, elliptical (Cauer) digital filter, with filter parameters as listed in Table 3.

Table 3. Audible and Tactile Warning Filter Parameters

Warning Type	Filter Order	Peak-to-Peak Ripple	Minimum Stop Band Attenuation	Passband Frequency Range
Audible	5 th	3 dB	60 dB	Identified Center Frequency \pm 5%
Tactile	5 th	3 dB	60 dB	Identified Center Frequency \pm 20%

APPENDIX A

Photographs

LIST OF FIGURES

	Page
Figure A1. Front View of Subject Vehicle	A-3
Figure A2. Rear View of Subject Vehicle	A-4
Figure A3. Window Sticker (Monroney Label).....	A-5
Figure A4. Vehicle Certification Label	A-6
Figure A5. Tire Placard	A-7
Figure A6. DGPS, Inertial Measurement Unit, and MicroAutoBox Installed in Subject Vehicle.....	A-8
Figure A7. Sensor for Detecting Visual Alerts	A-9
Figure A8. Sensor for Detecting Haptic Alerts.....	A-10
Figure A9. Computer Installed in Test Vehicle	A-11
Figure A10. Controls for Interacting with LDW Settings	A-12
Figure A11. LDW Menus.....	A-13
Figure A12. LDW Visual Alert	A-14



Figure A1. Front View of Subject Vehicle
A-3



Figure A2. Rear View of Subject Vehicle



2020 NISSAN ALTIMA

2.5 SV FWD SEDAN



Standard Equipment Included at No Extra Charge

MECHANICAL & PERFORMANCE

2.5L DOHC 16-valve I-4 Engine
188 Horsepower, 180 lb-ft Torque
Xtronic CVT®
(Continuously Variable Transmission)

SAFETY & SECURITY

Driver & Front Passenger Side Impact & Curtain Airbags
Driver & Front Passenger Knee Air Bags
Rear Outboard Passenger Side-Impact Air Bags
Lower Anchors and Tethers for Children (LATCH)
Automatic Emergency Braking (AEB) w/ Pedestrian Detection
Intelligent Forward Collision Warning (I-FCW)
Rear Automatic Braking (RAB)
Blind Spot Warning (BSW)
Rear Cross Traffic Alert (RCTA)
Lane Departure Warning (LDW)
Intelligent Lane Intervention (ILLI)
High Beam Assist (HBA)
RearView Monitor
Vehicle Dynamic Control System (VDC)
Traction Control System (TCS)
Tire Pressure Monitoring System (TPMS) w/ Easy Fill Tire Alert
Nissan Vehicle Immobilizer System
Vehicle Security System (VSS)

COMFORT & CONVENIENCE

Power Sliding Moonroof w/ Tilt
8-way Power Driver Seat w/ Power Lumbar
60/40 Split Fold-Down Rear Seats
Heated Front Seats
Heated Steering Wheel
Dual Zone Automatic Climate Control
Heated Outside Mirrors w/ Integrated LED Turn Signals
Remote Engine Start w/ Intelligent Climate Control
Electronic Parking Brake w/ Auto Hold
Rear Sonar System
Auto-Dimming Rearview Mirror w/ Homelink®
ProPILOT Assist
Steering Assist
Intelligent Cruise Control (ICC) w/ Full Speed Range and Hold

COMFORT & CONVENIENCE CONT.

Nissan Intelligent Key® w/ Push Button Ignition
NissanConnect® featuring Apple CarPlay®+ and Android Auto™ +
8" Color Display w/ Multi-Touch Control
SiriusXM® Radio+
Bluetooth® Hands-free Phone System+
Streaming Audio via Bluetooth®+
Hands-free Text Messaging Assistant+
Sirius Eyes Free+
Two Front Illuminated USB Charge Ports
7" Advanced Drive Assist Display (ADAD)
Intelligent Driver Alertness (I-DA)
6 Speakers
Two Rear Illuminated USB Charge Ports
Power Front Windows w/ One-Touch Auto Up/Down and Auto-Reverse Feature
Manual Tilt and Telescoping Steering Column
Intelligent Auto Headlight (I-AH)
Power Door Locks w/ Auto Locking
Steering Wheel Audio Switches
Rear Door Alert
Hill Start Assist

EXTERIOR

17" Alloy Wheels
LED Fog Lamps
LED Projector Headlights w/ Signature DTRL
Body-colored Power Outside Mirrors
Exhaust Finishers

+For more information, see dealer, owner's manual, or www.NissanUSA.com/connect/important-information.
++Optional Equipment Replaces Standard Where Applicable

Manufacturer's Suggested Retail Base Price. \$27,880.00

Options included by Manufacturer
SPLASH GUARDS 205.00
FLOOR MATS, TRUNK MAT, HIDEAWAY NET, & DUAL TRUNK HOOKS 300.00

DESTINATION CHARGES 895.00

Total* \$29,280.00

EPA DOT Fuel Economy and Environment Gasoline Vehicle

Fuel Economy MID-SIZE CARS range from 12 to 136 MPG. The best vehicle rates 136 MPG.

32 MPG combined city/hwy
28 city
39 highway

3.1 gallons per 100 miles

You save \$1,250 in fuel costs over 5 years compared to the average new vehicle.

Annual fuel cost \$1,250

Fuel Economy & Greenhouse Gas Rating (EPA only) **7** (Best)

Smog Rating (EPA only) **7** (Best)

Actual results will vary for many reasons, including driving conditions and how you drive and maintain your vehicle. The average new vehicle gets 27 MPG and costs \$7,500 to fuel over 5 years. Cost estimates are based on 15,000 miles per year at \$2.70 per gallon. MPGe is miles per gasoline gallon equivalent. Vehicle emissions are a significant cause of climate change and smog.

fueleconomy.gov Calculate personalized estimates and compare vehicles

Smartphone QR Code

GOVERNMENT 5-STAR SAFETY RATINGS DELIVERY

Overall Vehicle Score ★★★★★
Based on the combined ratings of frontal, side and rollover. Should ONLY be compared to other vehicles of similar size and weight.

Frontal Crash Driver ★★★★★ Passenger ★★★
Based on the risk of injury in a frontal impact. Should ONLY be compared to other vehicles of similar size and weight.

Side Crash Front seat ★★★★★ Rear seat ★★★★★
Based on the risk of injury in a side impact.

Rollover ★★★★★
Based on the risk of rollover in a single-vehicle crash.

Star ratings range from 1 to 5 stars (★★★★★) with 5 being the highest.
Source: National Highway Traffic Safety Administration (NHTSA)
www.safercar.gov or 1-888-327-4236

This Vehicle qualifies for Nissan's **Security+Plus Extended Protection Plan**
The only service agreement backed by Nissan Extended Services North America!
Ask your dealer for details, or call 1-800-NISSAN-1 for more information

VEHICLE COLORS:
EXT: GUN METALLIC
INT: CHARCOAL

FINAL ASSEMBLY POINT:
SMYRNA

TRANSPORT METHOD:
TRUCK

DEALER

VIN: 1N4BL4DV2LC19
EMS: 50 STATE EMISSIONS
MDL: 13510-190562 KAD-G
OPT: C-10L94C03G02

This vehicle is equipped with bumpers that can withstand an impact of 2.5 miles per hour with no damage to the vehicle's body and safety systems, although the bumper and related components may sustain damage. The bumper system on this vehicle conforms to the current federal bumper standard of 2.5 miles per hour.

2019110122427A3

Figure A3. Window Sticker (Monroney Label)

MFD BY NISSAN MOTOR CO., LTD.

DATE: 10/19

GVWR: 1963 KG

4328 LB

GAWR FR.: 1097 KG

2418 LB

GAWR RR.: 945 KG

2083 LB

THIS VEHICLE CONFORMS TO ALL APPLICABLE FEDERAL MOTOR VEHICLE SAFETY, BUMPER, AND THEFT PREVENTION STANDARDS IN EFFECT ON THE DATE OF MANUFACTURE SHOWN ABOVE.

1N4BL4DV2LC 19

PASSENGER CAR 995

MODEL: BDBALHZL34DUA--ACA

COLOR: KAD TRIM: G 9N00A



Figure A4. Vehicle Certification Label

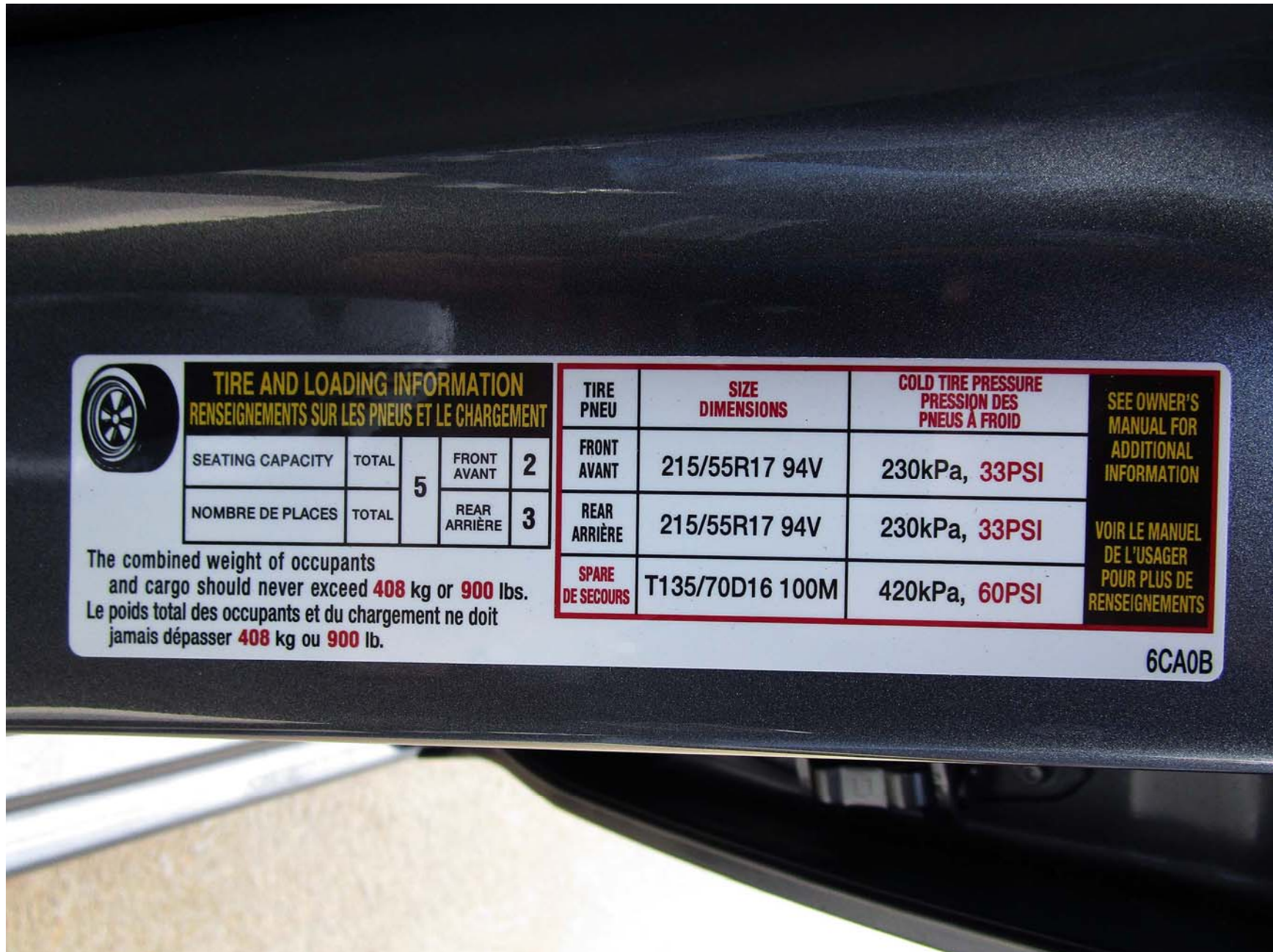

TIRE AND LOADING INFORMATION
RENSEIGNEMENTS SUR LES PNEUS ET LE CHARGEMENT

SEATING CAPACITY	TOTAL	5	FRONT AVANT	2
NOMBRE DE PLACES	TOTAL		REAR ARRIÈRE	3

The combined weight of occupants and cargo should never exceed **408 kg** or **900 lbs.**
 Le poids total des occupants et du chargement ne doit jamais dépasser **408 kg** ou **900 lb.**

TIRE PNEU	SIZE DIMENSIONS	COLD TIRE PRESSURE PRESSION DES PNEUS À FROID
FRONT AVANT	215/55R17 94V	230kPa, 33PSI
REAR ARRIÈRE	215/55R17 94V	230kPa, 33PSI
SPARE DE SECOURS	T135/70D16 100M	420kPa, 60PSI

SEE OWNER'S MANUAL FOR ADDITIONAL INFORMATION
 VOIR LE MANUEL DE L'USAGER POUR PLUS DE RENSEIGNEMENTS

6CA0B

Figure A5. Tire Placard



Figure A6. DGPS, Inertial Measurement Unit, and MicroAutoBox Installed in Subject Vehicle



Figure A7. Sensor for Detecting Visual Alerts



Figure A8. Sensor for Detecting Haptic Alerts



Figure A9. Computer Installed in Test Vehicle



Figure A10. Controls for Interacting with LDW Settings



Figure A11. LDW Menus



Figure A12. LDW Visual Alert

APPENDIX B

Excerpts from Owner's Manual

Driver Assistance

The driver assistance menu allows the user to change the settings for driving, parking, and braking aids.

Menu item		Result
Steering Assist (if so equipped)		Allows user to turn the Steering Assist of the ProPILOT Assist system on or off. For additional information, please refer to "ProPILOT Assist" in the "Starting and driving" section of this manual.
Emergency Brake		Displays available emergency braking options.
	Front	Allows user to turn the front emergency braking system on or off. For additional information, refer to "Automatic Emergency Braking (AEB)", "Automatic Emergency Braking (AEB) with Pedestrian Detection" and "Intelligent Forward Collision Warning (I-FCW)" in the "Starting and driving" section of this manual.
	Rear (if so equipped)	Allows user to turn the rear emergency braking system on or off. For additional information, refer to "Rear Automatic Braking (RAB)" in the "Starting and driving" section of this manual.
Lane (if so equipped)		Displays available lane options.
	Lane Departure Warning	Allows user to turn the Lane Departure Warning (LDW) system on or off. For additional information, refer to "Lane Departure Warning (LDW)" in the "Starting and driving" section of this manual.
	Lane Departure Prevention (if so equipped)	Allows user to turn Intelligent Lane Intervention (I-LI) system on or off. For additional information, refer to "Intelligent Lane Intervention (I-LI)" in the "Starting and driving" section of this manual.
Blind Spot (if so equipped)		Displays available blind spot options.
	Blind Spot Warning	Allows user to turn the Blind Spot Warning (BSW) system on or off. For additional information, refer to "Blind Spot Warning (BSW)" in the "Starting and driving" section of this manual.
	Side Indicator Brightness	Allows user to change the brightness of the side indicator.
Speed Limit Sign (if so equipped)		Allows user to turn the Speed Limit Sign recognition on or off. For additional information, refer to "Traffic Sign Recognition" in the "Starting and driving" section of this manual.
Parking Aids (if so equipped)		Displays available parking aids.
	Auto Show Sonar	Allows user to auto display the sonar. For additional information, refer to "Rear Sonar System (RSS)" in the "Starting and driving" section of this manual.
	Rear	Allows user to turn the rear sonar on or off.
	Distance	Allows user to set the distance sensor range to Long/Medium/Short.

Activate the drive sport mode by pushing the switch on the shift lever while the shift lever is in the D (Drive) position.

For additional information, refer to "Driving the vehicle" in the "Starting and driving" section of this manual.

Intelligent Lane Intervention (I-LI) indicator (if so equipped)

This indicator shows when the I-LI system is engaged.

For additional information, refer to "Intelligent Lane Intervention (I-LI)" in the "Starting and driving" section of this manual.

Lane Departure Warning (LDW) indicator (if so equipped)

This indicator shows when the LDW system is engaged.

For additional information, refer to "Lane Departure Warning (LDW)" and "Intelligent Lane Intervention (I-LI)" in the "Starting and driving" section of this manual.

Rear Automatic Braking (RAB) indicator (if so equipped)

This indicator illuminates to indicate the status of the Rear Automatic Braking (RAB) system. For additional information, refer to

"Rear Automatic Braking (RAB)" in the "Starting and driving" section of this manual.

Steering Assist Alert (if so equipped)

This message may appear when the Steering Assist system is engaged.

It will be displayed under the following condition:

- When not holding the steering wheel or when there is no steering wheel operation

Please hold on the steering wheel immediately. When the steering operation is detected, the warning turns off and the steering assist function is automatically restored.

Steering Assist indicator (if so equipped)

This indicator appears when the Steering Assist system is engaged.

For additional information, refer to "ProPILOT Assist" in the "Starting and driving" section of this manual.

Transmission Shift Position indicator

This indicator shows the transmission shift position.

Vehicle ahead detection indicator

This indicator shows when the Automatic Emergency Braking (AEB) system is engaged and has detected a vehicle.

For additional information, refer to "Automatic Emergency Braking (AEB)" or "Automatic Emergency Braking (AEB) with Pedestrian Detection" in the "Starting and driving" section of this manual.

button ignition switch positions" in the "Starting and driving" section of this manual.

Power turned off to save the battery

This message appears after the ignition switch is automatically turned off. For additional information, refer to "Push-button ignition switch positions" in the "Starting and driving" section of this manual.

Reminder: Turn OFF Headlights

This warning appears when the headlights are left in the ON position when exiting the vehicle. Place the headlight switch in the OFF or AUTO position. For additional information, refer to "Headlight and turn signal switch" in this section.

Headlight System Error: See Owner's Manual (if so equipped)

This warning illuminates when there is an error with the system. For additional information, refer to "Headlight and turn signal switch" in this section.

Parking Sensor Error: See Owner's Manual (if so equipped)

This warning illuminates when there is an error with the system. For additional information,

refer to "Rear Sonar System (RSS)" in the "Starting and driving" section of this manual.

Driver Attention Alert Malfunction

This warning appears when the Intelligent Driver Alertness (I-DA) system is not functioning properly. For additional information, refer to "Intelligent Driver Alertness (I-DA)" in the "Starting and driving" section of this manual.

Malfunction: See Owner's Manual (if so equipped)

This warning appears when one or more of the following systems (if so equipped) is not functioning properly:

- Traffic Sign Recognition (TSR)
- Rear Automatic Braking (RAB)

If one or more of these warning appears, have the system checked. It is recommended that you visit a NISSAN dealer for this service.

Unavailable: Side Radar Obstruction (if so equipped)

This message appears when the Blind Spot Warning (BSW)/Rear Cross Traffic Alert (RCTA) systems become unavailable be-

cause a radar blockage is detected. For additional information, refer to "Blind Spot Warning (BSW)" or "Rear Cross Traffic Alert (RCTA)" in the "Starting and driving" section of this manual.

Unavailable: High Cabin Temperature (if so equipped)

This message appears when the camera detects an interior temperature of more than 104°F (40°C). For additional information, refer to "Automatic Emergency Braking (AEB)", "Automatic Emergency Braking (AEB) with Pedestrian Detection", "Intelligent Cruise Control (ICC)", "Intelligent Lane Intervention (I-LI)" or "Lane Departure Warning (LDW)" in the "Starting and driving" section of this manual.

Time for a break?

This message appears when the set time is reached. This time can be set up to six hours. For additional information, refer to "Settings" in this section.

Driver Attention Alert— Take a Break?

This alert appears when the system has detected that the driver may be displaying fatigue or a lack of attention.

the D (Drive) position to P (Park) position, and the driver exits the vehicle. This message alerts the driver, after a period of time, to check for items in the rear seat after the audible alert has been provided.

NOTE:

This system is disabled until a driver enables it using the vehicle information display. For additional information, refer to "How to use the vehicle information display" in this section.

For additional information, refer to "Rear Door Alert" in this section.

Intelligent Cruise Control (ICC) indicators (if so equipped)

These indicators show the Intelligent Cruise Control (ICC) system status. The status is shown by color. For additional information, refer to "Intelligent Cruise Control (ICC) (for vehicles without ProPILOT Assist)" in the "Starting and driving" section of this manual.

Intelligent Cruise Control (ICC) (for vehicles with ProPILOT Assist) indicators (if so equipped)

These indicators show the ProPILOT Assist with Intelligent Cruise Control (ICC) system

status. The status is shown by color. For additional information, refer to "Intelligent Cruise Control (ICC) (for vehicles with ProPILOT Assist)" in the "Starting and driving" section of this manual.

Speed Limit Sign indicator (if so equipped)

This message may appear when the Traffic Sign Recognition system is engaged.

For additional information, refer to "Traffic Sign Recognition (TSR)" in the "Starting and driving" section of this manual.

Chassis Control System Error: See Owner's Manual (if so equipped)

This warning appears if there is an error in the Automatic Brake Hold system. Have the system checked. It is recommended that you visit a NISSAN dealer for this service. For additional information, refer to "Chassis control" or "Automatic brake hold" in the "Starting and driving" section of this manual.

Not Available System Malfunction (if so equipped)

This warning appears when one or more of the following systems (if so equipped) is not functioning properly.

- Intelligent Cruise Control (ICC)
- ProPILOT
- Blind Spot Warning (BSW)
- Lane Departure Warning (LDW)
- Intelligent Lane Intervention (I-LI)

If one or more of these warnings appear, have the system checked. It is recommended that you visit a NISSAN dealer for this service.

For additional information, refer to "Intelligent Cruise Control (ICC) (for vehicles without ProPILOT Assist)", "ProPILOT Assist", "Blind Spot Warning (BSW)", "Lane Departure Warning (LDW)" or "Intelligent Lane Intervention (I-LI)" in the "Starting and driving" section of this manual.

Not Available Seat Belt Not Fastened (if so equipped)

This message may appear when the Intelligent Cruise Control (ICC) (with ProPILOT Assist) system is engaged.

Under the following condition, the ICC (with ProPILOT Assist) system is automatically canceled:

- When the driver's seat belt is not fastened

CAUTION

- Except in an emergency, do not shift to the N (Neutral) position while driving. Coasting with the transmission in the N (Neutral) position may cause serious damage to the transmission.
- To avoid possible damage to your vehicle, when stopping the vehicle on an uphill grade, do not hold the vehicle by depressing the accelerator pedal. The foot brake should be used for this purpose.

The CVT in your vehicle is electronically controlled to produce maximum power and smooth operation.

Follow these procedures for maximum vehicle performance and driving enjoyment.

NOTE:

Engine power may be automatically reduced to protect the CVT if the engine speed increases quickly when driving on slippery roads or while being tested on some dynamometers.

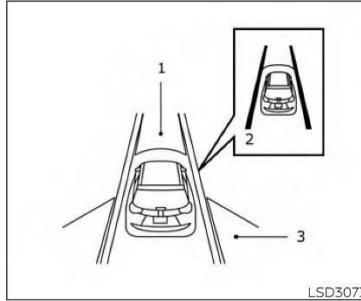

1. Automatic Emergency Braking (AEB)
2. Lane Departure Warning (LDW) when shaded and Intelligent Lane Intervention (I-LI) when solid
3. Blind Spot Warning (BSW)

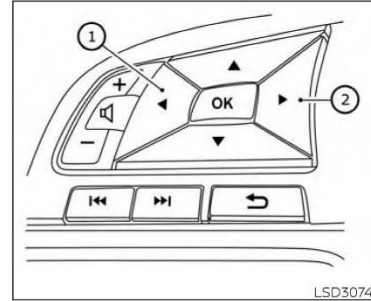

Starting the vehicle

1. After starting the engine, fully depress the foot brake pedal before moving the shift lever out of the P (Park) position. **The Continuously Variable Transmission is designed so the foot brake pedal MUST be depressed before shifting from P (Park) to any drive position while the ignition switch is in the ON position. The shift lever cannot be moved out of P (Park) and into any of the other gear positions if the ignition switch is placed in the LOCK position.**

Starting and driving 5-19

2. A screen is displayed for a period of time that indicates the status of the driving aid functions (if so equipped).
 - AEB, LDW, and BSW are enabled when the specified driving aid is shaded.
 - I-LI is enabled when the driving aid is solid.
 - Use the ① ◀ or ② ▶ button to navigate the settings screen. For additional information, refer to "How to use the vehicle information display" in the "Instruments and controls" section of this manual.
3. Keep the foot brake pedal depressed and move the shift lever to a driving position.
4. Release the foot brake, then gradually start the vehicle in motion.
5. Stop the vehicle completely before moving the shift lever to the P (Park) position.

⚠ WARNING

- Do not depress the accelerator pedal while shifting from P (Park) or N (Neutral) to R (Reverse), D (Drive), L (Low) or manual shift mode (if so equipped). Always depress the brake pedal until shifting is completed. Failure to do so could cause you to lose control and have an accident.
- Cold engine idle speed is high, so use caution when shifting into a forward or reverse gear before the engine has warmed up.
- Do not downshift abruptly on slippery roads. This may cause a loss of control.
- Never shift to either the P (Park) or R (Reverse) position while the vehicle is moving forward and P (Park) or D (Drive) position while the vehicle is reversing. This could cause an accident or damage the transmission.

⚠ CAUTION

- Except in an emergency, do not shift to the N (Neutral) position while driving. Coasting with the transmission in the N (Neutral) position may cause serious damage to the transmission.
- To avoid possible damage to your vehicle, when stopping the vehicle on an uphill grade, do not hold the vehicle by depressing the accelerator pedal. The foot brake should be used for this purpose.

5-20 Starting and driving

LANE DEPARTURE WARNING (LDW) (if so equipped)

SYSTEM MAINTENANCE

The TSR system uses the same multi-sensing front camera unit that is used by the Lane Departure Warning (LDW) system, located in front of the interior rearview mirror. For additional information, refer to "System maintenance" in the "Lane Departure Warning (LDW)" section.

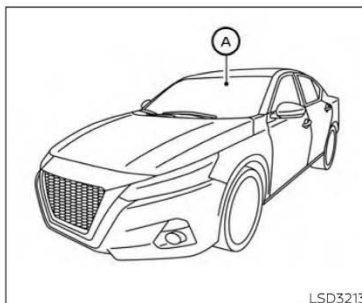

The LDW system will operate when the vehicle is driven at speeds of approximately 37 mph (60 km/h) and above, and only when the lane markings are clearly visible on the road.

The LDW system monitors the lane markers on the traveling lane using the camera unit (A) located above the inside mirror.

The LDW system warns the driver that the vehicle is beginning to leave the driving lane with an indicator and a steering wheel vibration. For additional information, refer to "LDW system operation" in this section.

⚠ WARNING

Failure to follow the warnings and instructions for proper use of the LDW system could result in serious injury or death.

- **This system is only a warning device to inform the driver of a potential unintended lane departure. It will not steer the vehicle or prevent loss of control. It is the driver's responsibility to stay alert, drive safely, keep the vehicle in the traveling lane, and be in control of the vehicle at all times.**

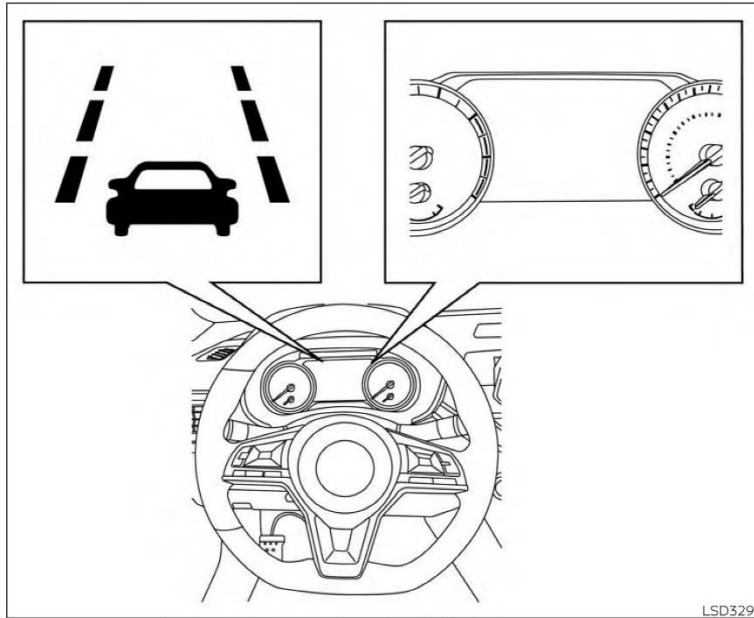

LDW SYSTEM OPERATION

The LDW system provides a lane departure warning function when the vehicle is driven at speeds of approximately 37 mph (60 km/h) and above and the lane markings are clear. When the vehicle approaches either the left or the right side of the traveling lane, the steering wheel will vibrate and the LDW indicator on the instrument panel will blink to alert the driver.

The warning function will stop when the vehicle returns inside of the lane markers.

Starting and driving 5-35

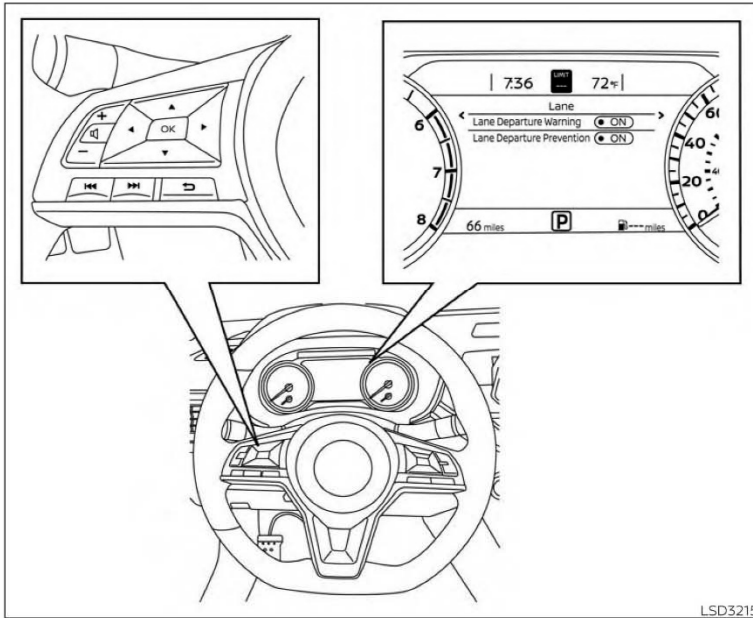

5-36 Starting and driving

LSD3215

HOW TO ENABLE/DISABLE THE LDW SYSTEM

Perform the following steps to enable or disable the LDW system.

1. Press the button until "Settings" displays in the vehicle information display. Use the button to select "Driver Assistance." Then press the OK button.
2. Select "Lane" and press the OK button.
3. Select "Lane Departure Warning" and press the OK button to turn the system on or off.

LDW SYSTEM LIMITATIONS

WARNING

Listed below are the system limitations for the LDW system. Failure to follow the warnings and instructions for proper use of the LDW system could result in serious injury or death.

- The system will not operate at speeds below approximately 37 mph (60 km/h) or if it cannot detect lane markers.

- Do not use the LDW system under the following conditions as it may not function properly:
 - During bad weather (rain, fog, snow, etc.).
 - When driving on slippery roads, such as on ice or snow.
 - When driving on winding or uneven roads.
 - When there is a lane closure due to road repairs.
 - When driving in a makeshift or temporary lane.
 - When driving on roads where the lane width is too narrow.
 - When driving without normal tire conditions (for example, tire wear, low tire pressure, installation of spare tire, tire chains, nonstandard wheels).
 - When the vehicle is equipped with non-original brake parts or suspension parts.
 - When you are towing a trailer or other vehicle.

- The system may not function properly under the following conditions:
 - On roads where there are multiple parallel lane markers; lane markers that are faded or not painted clearly; yellow painted lane markers; non-standard lane markers; or lane markers covered with water, dirt, snow, etc.
 - On roads where the discontinued lane markers are still detectable.
 - On roads where there are sharp curves.
 - On roads where there are sharply contrasting objects, such as shadows, snow, water, wheel ruts, seams or lines remaining after road repairs. (The LDW system could detect these items as lane markers.)
 - On roads where the traveling lane merges or separates.
 - When the vehicle's traveling direction does not align with the lane marker.

- When traveling close to the vehicle in front of you, which obstructs the lane camera unit detection range.
- When rain, snow, dirt or an object adheres to the windshield in front of the lane camera unit.
- When the headlights are not bright due to dirt on the lens or if the aiming is not adjusted properly.
- When strong light enters the lane camera unit. (For example, the light directly shines on the front of the vehicle at sunrise or sunset.)
- When a sudden change in brightness occurs. (For example, when the vehicle enters or exits a tunnel or under a bridge.)

SYSTEM TEMPORARILY UNAVAILABLE

If the vehicle is parked in direct sunlight under high temperature conditions (over approximately 104°F [40°C]) and then started, the LDW system may be deactivated automatically and the following message will appear in the vehicle information display: "Unavailable: High Cabin Temperature."

Starting and driving 5-37

When the interior temperature is reduced, the LDW system will resume operating automatically.

The LDW system is not designed to warn under the following conditions:

- When you operate the lane change signal and change traveling lanes in the direction of the signal. (The LDW system will become operable again approximately 2 seconds after the lane change signal is turned off.)
- When the vehicle speed lowers to less than approximately 37 mph (60 km/h).

After the above conditions have finished and the necessary operating conditions are satisfied, the LDW functions will resume.

SYSTEM MALFUNCTION

If the LDW system malfunctions, it will cancel automatically and "Not Available System Malfunction" will appear in the vehicle information display. If "Not Available System Malfunction" appears in the vehicle information display, pull off the road to a safe location and stop the vehicle. Place the shift lever in the P (Park) position and the ignition switch in the OFF position and restart the engine/motor. If "Not Available System Malfunction" continues to appear

in the vehicle information display, have the system checked. It is recommended that you visit a NISSAN dealer for this service.

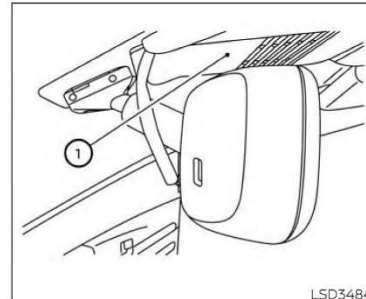

LSD3484

SYSTEM MAINTENANCE

The lane camera unit ① for the LDW system is located above the inside mirror. To keep the proper operation of the LDW system and prevent a system malfunction, be sure to observe the following:

- Always keep the windshield clean.
- Do not attach a sticker (including transparent material) or install an accessory near the camera unit.

INTELLIGENT LANE INTERVENTION (I-LI) (if so equipped)

- Do not place reflective materials, such as white paper or a mirror, on the instrument panel. The reflection of sunlight may adversely affect the camera unit's capability of detecting the lane markers.
- Do not strike or damage the areas around the camera unit. Do not touch the camera lens or remove the screw located on the camera unit. If the camera unit is damaged due to an accident, it is recommended that you visit a NISSAN dealer.

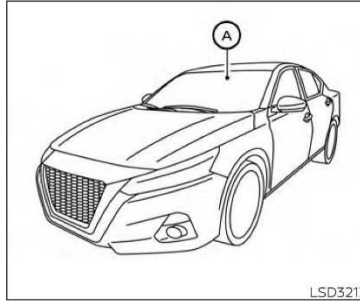

⚠ WARNING

Failure to follow the warnings and instructions for proper use of the I-LI system could result in serious injury or death.

- **The I-LI system will not steer the vehicle or prevent loss of control. It is the driver's responsibility to stay alert, drive safely, keep the vehicle in the traveling lane, and be in control of the vehicle at all times.**

- **The I-LI system is primarily intended for use on well-developed freeways or highways. It may not detect the lane markers in certain road, weather, or driving conditions.**

The I-LI system must be turned on with the ProPILOT Assist switch (for vehicles with ProPILOT Assist) on the steering wheel, every time the ignition is placed in the ON position.

The I-LI system will operate when the vehicle is driven at speeds of approximately 37 mph (60 km/h) and above, and only when the lane markings are clearly visible on the road.

The I-LI system warns the driver when the vehicle has left the center of the traveling lane with an indicator and a steering wheel vibration. The system helps assist the driver to return the vehicle to the center of the traveling lane by applying the brakes to the left or right wheels individually (for a short period of time).

The I-LI system monitors the lane markers on the traveling lane using the camera unit (A) located above the inside mirror.

Starting and driving 5-39

APPENDIX C

Run Log

Subject Vehicle: **2020 Nissan Altima**

Test Date: **2/11/2020**

Driver: **A. Ricci**

Note: For Distance at Warning positive values indicate inside the lane

Run	Lane Marking Type	Departure Direction	Valid Run?	Distance at Visual Alert (ft)	Distance at Haptic Alert (ft)	Pass/Fail	Notes
1	Botts	Right	Y	0.14	0.15	Pass	
2			N				Lateral Velocity
3			Y	-0.18	-0.13	Pass	
4			Y	-0.08	0.04	Pass	
5			Y	-0.03	0.08	Pass	
6			Y	-0.18	-0.06	Pass	
7			Y	-0.03	-0.07	Pass	
8			Y	-0.09	-0.02	Pass	
9	Botts	Left	Y	0.21	0.18	Pass	
10			Y	0.21	0.28	Pass	
11			Y	0.12	0.13	Pass	
12			Y	0.13	0.09	Pass	
13			Y	0.17	0.19	Pass	
14			Y	0.10	0.21	Pass	
15			Y	0.20	0.12	Pass	

Run	Lane Marking Type	Departure Direction	Valid Run?	Distance at Visual Alert (ft)	Distance at Haptic Alert (ft)	Pass/Fail	Notes
16	Solid	Left	Y	0.16	-0.06	Pass	
17			Y	0.04	0.13	Pass	
18			Y	0.08	0.18	Pass	
19			Y	0.13	0.08	Pass	
20			Y	-0.05	0.03	Pass	
21			Y	0.07	0.03	Pass	
22			Y	0.07	0.10	Pass	
23	Solid	Right	Y	0.05	0.07	Pass	
24			Y	-0.09	0.05	Pass	
25			Y	0.06	0.17	Pass	
26			Y	0.02	0.07	Pass	
27			Y	0.10	0.14	Pass	
28			Y	0.05	0.08	Pass	
29			Y	0.13	0.16	Pass	
30	Dashed	Right	Y	0.13	0.23	Pass	
31			Y	-0.04	0.03	Pass	
32			Y	0.05		Pass	Haptic Sensor Error
33			Y	-0.01	0.21	Pass	
34			Y	0.11	0.28	Pass	
35			Y	0.09	0.08	Pass	
36			Y	0.01	0.23	Pass	

Run	Lane Marking Type	Departure Direction	Valid Run?	Distance at Visual Alert (ft)	Distance at Haptic Alert (ft)	Pass/Fail	Notes
37	Dashed	Left	Y	0.15	0.17	Pass	
38			Y	0.20	0.19	Pass	
39			Y	0.12		Pass	Haptic Sensor Error
40			Y	0.18	0.25	Pass	
41			Y	0.17	0.16	Pass	
42			Y	0.07	0.12	Pass	
43			Y	0.17	0.22	Pass	

APPENDIX D

Time History Plots

LIST OF FIGURES

	Page
Figure D1. Example Time History for Lane Departure Warning Test, Passing.....	D-8
Figure D2. Example Time History for Lane Departure Warning Test, Failing, No Warning Issued.....	D-9
Figure D3. Example Time History for Lane Departure Warning Test, Invalid Run Due to Subject Vehicle Yaw Rate	D-10
Figure D4. Time History for Run 01, Botts Dots, Right Departure, Haptic Warning.....	D-11
Figure D5. Time History for Run 01, Botts Dots, Right Departure, Visual Warning	D-12
Figure D6. Time History for Run 03, Botts Dots, Right Departure, Haptic Warning.....	D-13
Figure D7. Time History for Run 03, Botts Dots, Right Departure, Visual Warning	D-14
Figure D8. Time History for Run 04, Botts Dots, Right Departure, Haptic Warning.....	D-15
Figure D9. Time History for Run 04, Botts Dots, Right Departure, Visual Warning	D-16
Figure D10. Time History for Run 05, Botts Dots, Right Departure, Haptic Warning.....	D-17
Figure D11. Time History for Run 05, Botts Dots, Right Departure, Visual Warning	D-18
Figure D12. Time History for Run 06, Botts Dots, Right Departure, Haptic Warning.....	D-19
Figure D13. Time History for Run 06, Botts Dots, Right Departure, Visual Warning	D-20
Figure D14. Time History for Run 07, Botts Dots, Right Departure, Haptic Warning.....	D-21
Figure D15. Time History for Run 07, Botts Dots, Right Departure, Visual Warning	D-22
Figure D16. Time History for Run 08, Botts Dots, Right Departure, Haptic Warning.....	D-23
Figure D17. Time History for Run 08, Botts Dots, Right Departure, Visual Warning	D-24
Figure D18. Time History for Run 09, Botts Dots, Left Departure, Haptic Warning	D-25
Figure D19. Time History for Run 09, Botts Dots, Left Departure, Visual Warning	D-26
Figure D20. Time History for Run 10, Botts Dots, Left Departure, Haptic Warning	D-27
Figure D21. Time History for Run 10, Botts Dots, Left Departure, Visual Warning	D-28
Figure D22. Time History for Run 11, Botts Dots, Left Departure, Haptic Warning	D-29
Figure D23. Time History for Run 11, Botts Dots, Left Departure, Visual Warning	D-30
Figure D24. Time History for Run 12, Botts Dots, Left Departure, Haptic Warning	D-31
Figure D25. Time History for Run 12, Botts Dots, Left Departure, Visual Warning	D-32
Figure D26. Time History for Run 13, Botts Dots, Left Departure, Haptic Warning	D-33
Figure D27. Time History for Run 13, Botts Dots, Left Departure, Visual Warning	D-34
Figure D28. Time History for Run 14, Botts Dots, Left Departure, Haptic Warning	D-35
Figure D29. Time History for Run 14, Botts Dots, Left Departure, Visual Warning	D-36
Figure D30. Time History for Run 15, Botts Dots, Left Departure, Haptic Warning	D-37
Figure D31. Time History for Run 15, Botts Dots, Left Departure, Visual Warning	D-38
Figure D32. Time History for Run 16, Solid Line, Left Departure, Haptic Warning.....	D-39
Figure D33. Time History for Run 16, Solid Line, Left Departure, Visual Warning	D-40
Figure D34. Time History for Run 17, Solid Line, Left Departure, Haptic Warning.....	D-41
Figure D35. Time History for Run 17, Solid Line, Left Departure, Visual Warning	D-42
Figure D36. Time History for Run 18, Solid Line, Left Departure, Haptic Warning.....	D-43
Figure D37. Time History for Run 18, Solid Line, Left Departure, Visual Warning	D-44
Figure D38. Time History for Run 19, Solid Line, Left Departure, Haptic Warning.....	D-45

Figure D39.	Time History for Run 19, Solid Line, Left Departure, Visual Warning	D-46
Figure D40.	Time History for Run 20, Solid Line, Left Departure, Haptic Warning	D-47
Figure D41.	Time History for Run 20, Solid Line, Left Departure, Visual Warning	D-48
Figure D42.	Time History for Run 21, Solid Line, Left Departure, Haptic Warning	D-49
Figure D43.	Time History for Run 21, Solid Line, Left Departure, Visual Warning	D-50
Figure D44.	Time History for Run 22, Solid Line, Left Departure, Haptic Warning	D-51
Figure D45.	Time History for Run 22, Solid Line, Left Departure, Visual Warning	D-52
Figure D46.	Time History for Run 23, Solid Line, Right Departure, Haptic Warning	D-53
Figure D47.	Time History for Run 23, Solid Line, Right Departure, Visual Warning	D-54
Figure D48.	Time History for Run 24, Solid Line, Right Departure, Haptic Warning	D-55
Figure D49.	Time History for Run 24, Solid Line, Right Departure, Visual Warning	D-56
Figure D50.	Time History for Run 25, Solid Line, Right Departure, Haptic Warning	D-57
Figure D51.	Time History for Run 25, Solid Line, Right Departure, Visual Warning	D-58
Figure D52.	Time History for Run 26, Solid Line, Right Departure, Haptic Warning	D-59
Figure D53.	Time History for Run 26, Solid Line, Right Departure, Visual Warning	D-60
Figure D54.	Time History for Run 27, Solid Line, Right Departure, Haptic Warning	D-61
Figure D55.	Time History for Run 27, Solid Line, Right Departure, Visual Warning	D-62
Figure D56.	Time History for Run 28, Solid Line, Right Departure, Haptic Warning	D-63
Figure D57.	Time History for Run 28, Solid Line, Right Departure, Visual Warning	D-64
Figure D58.	Time History for Run 29, Solid Line, Right Departure, Haptic Warning	D-65
Figure D59.	Time History for Run 29, Solid Line, Right Departure, Visual Warning	D-66
Figure D60.	Time History for Run 30, Dashed Line, Right Departure, Haptic Warning	D-67
Figure D61.	Time History for Run 30, Dashed Line, Right Departure, Visual Warning	D-68
Figure D62.	Time History for Run 31, Dashed Line, Right Departure, Haptic Warning	D-69
Figure D63.	Time History for Run 31, Dashed Line, Right Departure, Visual Warning	D-70
Figure D64.	Time History for Run 32, Dashed Line, Right Departure, Visual Warning	D-71
Figure D65.	Time History for Run 33, Dashed Line, Right Departure, Haptic Warning	D-72
Figure D66.	Time History for Run 33, Dashed Line, Right Departure, Visual Warning	D-73
Figure D67.	Time History for Run 34, Dashed Line, Right Departure, Haptic Warning	D-74
Figure D68.	Time History for Run 34, Dashed Line, Right Departure, Visual Warning	D-75
Figure D69.	Time History for Run 35, Dashed Line, Right Departure, Haptic Warning	D-76
Figure D70.	Time History for Run 35, Dashed Line, Right Departure, Visual Warning	D-77
Figure D71.	Time History for Run 36, Dashed Line, Right Departure, Haptic Warning	D-78
Figure D72.	Time History for Run 36, Dashed Line, Right Departure, Visual Warning	D-79
Figure D73.	Time History for Run 37, Dashed Line, Left Departure, Haptic Warning	D-80
Figure D74.	Time History for Run 37, Dashed Line, Left Departure, Visual Warning	D-81
Figure D75.	Time History for Run 38, Dashed Line, Left Departure, Haptic Warning	D-82
Figure D76.	Time History for Run 38, Dashed Line, Left Departure, Visual Warning	D-83
Figure D77.	Time History for Run 39, Dashed Line, Left Departure, Visual Warning	D-84
Figure D78.	Time History for Run 40, Dashed Line, Left Departure, Haptic Warning	D-85
Figure D79.	Time History for Run 40, Dashed Line, Left Departure, Visual Warning	D-86
Figure D80.	Time History for Run 41, Dashed Line, Left Departure, Haptic Warning	D-87
Figure D81.	Time History for Run 41, Dashed Line, Left Departure, Visual Warning	D-88

Figure D82. Time History for Run 42, Dashed Line, Left Departure, Haptic Warning	D-89
Figure D83. Time History for Run 42, Dashed Line, Left Departure, Visual Warning	D-90
Figure D84. Time History for Run 43, Dashed Line, Left Departure, Haptic Warning	D-91
Figure D85. Time History for Run 43, Dashed Line, Left Departure, Visual Warning	D-92

Description of Time History Plots

A set of time history plots is provided for each valid run in the test series. Each set of plots comprises time varying data from the Subject Vehicle, as well as pass/fail envelopes and thresholds. The following is a description of data types shown in the time history plots, as well as a description of the color code for data envelopes.

Time History Plot Description

Time history figures include the following sub-plots:

- Warning – Indicates timing of warning issued by LDW system. Depending on the type of LDW alert or instrumentation used to measure the alert, this can be any of the following:
 - Filtered and rectified sound signal
 - Filtered and rectified acceleration (e.g., steering wheel vibration)
 - Light sensor signal
 - Discrete on/off value
- Speed (mph) – Speed of the Subject Vehicle
- Yaw Rate (deg/sec) – Yaw rate of the Subject Vehicle
- Distance to Lane Edge (ft) – Lateral distance (in lane coordinates) from the outer front tire bulge to the inside edge of the lane marking of interest for a given test (a positive value indicates the vehicle is completely within the lane while a negative value indicates that the outer front tire bulge has crossed over the inner lane marking edge). The distance to the lane edge at the moment the LDW alert is issued, is displayed to the right of subplot.
- Lateral Lane Velocity (ft/sec) – Lateral velocity (in lane coordinates) of the outer front tire bulge
- Bird's Eye View – Indicates the position of the Subject Vehicle with respect to the lane marking of interest for a given test. Green rectangles represent the Subject Vehicle's position at approximately 2 second intervals, while the yellow rectangle indicates the position of the Subject Vehicle at the time of LDW warning issuance.

Envelopes and Thresholds

Each of the time history plot figures can contain either green or yellow envelopes and/or black threshold lines. These envelopes and thresholds are used to programmatically and visually determine the validity of a given test run. Envelope and threshold exceedances are indicated with either red shading or red asterisks, and red text is placed to the right side of the plot indicating the type of exceedance.

Green envelopes indicate that the time-varying data should not exceed the envelope boundaries at any time within the envelope. Exceedances of a green envelope are indicated by red shading in the area between the measured time-varying data and the envelope boundaries.

Yellow envelopes indicate that the time-varying data should not exceed the envelope only at the right end. Exceedances at the right extent of a yellow envelope are indicated by red asterisks. Data within the boundaries at the right extent of a yellow envelope are indicated by green circles.

For the warning plot, a dashed black threshold line indicates the threshold used to determine the onset of the LDW alert. The alert is considered on the first time the alert signal crosses this threshold line.

Color Codes

Color codes have been adopted to easily identify the types of data, envelopes, and thresholds used in the plots.

Color codes can be broken into three categories:

1. Validation envelopes and thresholds
 1. Validation envelopes and thresholds
 2. Instantaneous samplings
 3. Text
1. Validation envelope and threshold color codes:
 - Green envelope = time varying data must be within the envelope at all times in order to be valid
 - Yellow envelope = time varying data must be within limits at right end
 - Black threshold (Solid) = time varying data must not exceed this threshold in order to be valid
 - Black threshold (Dashed) = for reference only – this can include warning level thresholds which are used to determine the timing of the alert
2. Instantaneous sampling color codes:
 - Green circle = passing or valid value at a given moment in time
 - Red asterisk = failing or invalid value at a given moment in time

3. Text color codes:

- Green = passing or valid value
- Red = failing or invalid value

Other Notations

- NG – Indicates that the value for that variable was outside of bounds and therefore “No Good”.
- No Wng – No warning was detected.

The minimum (worst) GPS fix type is displayed in the lower right corner of each page. The only valid fix type is RTK fixed (displayed in green). If the fix type during any portion of the test was anything other than RTK fixed, then “RTK Fixed OR LESS!!” is displayed in red.

Examples of time history plots (including passing, failing and invalid runs) are shown in Figure D1 through Figure D3. Actual time history data plots for the vehicle under consideration are provided subsequently.

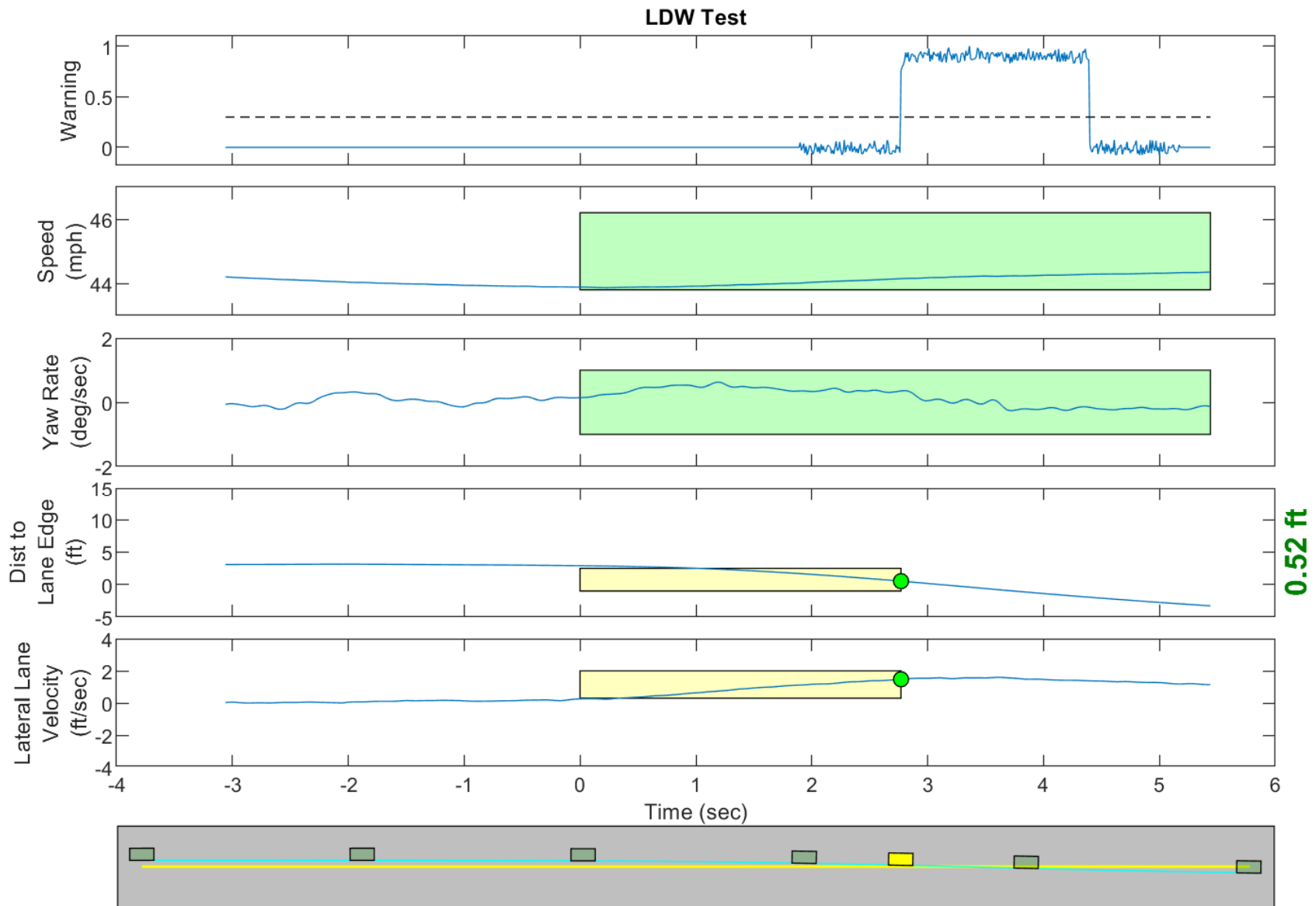

GPS Fix Type: RTK Fixed

Figure D1. Example Time History for Lane Departure Warning Test, Passing

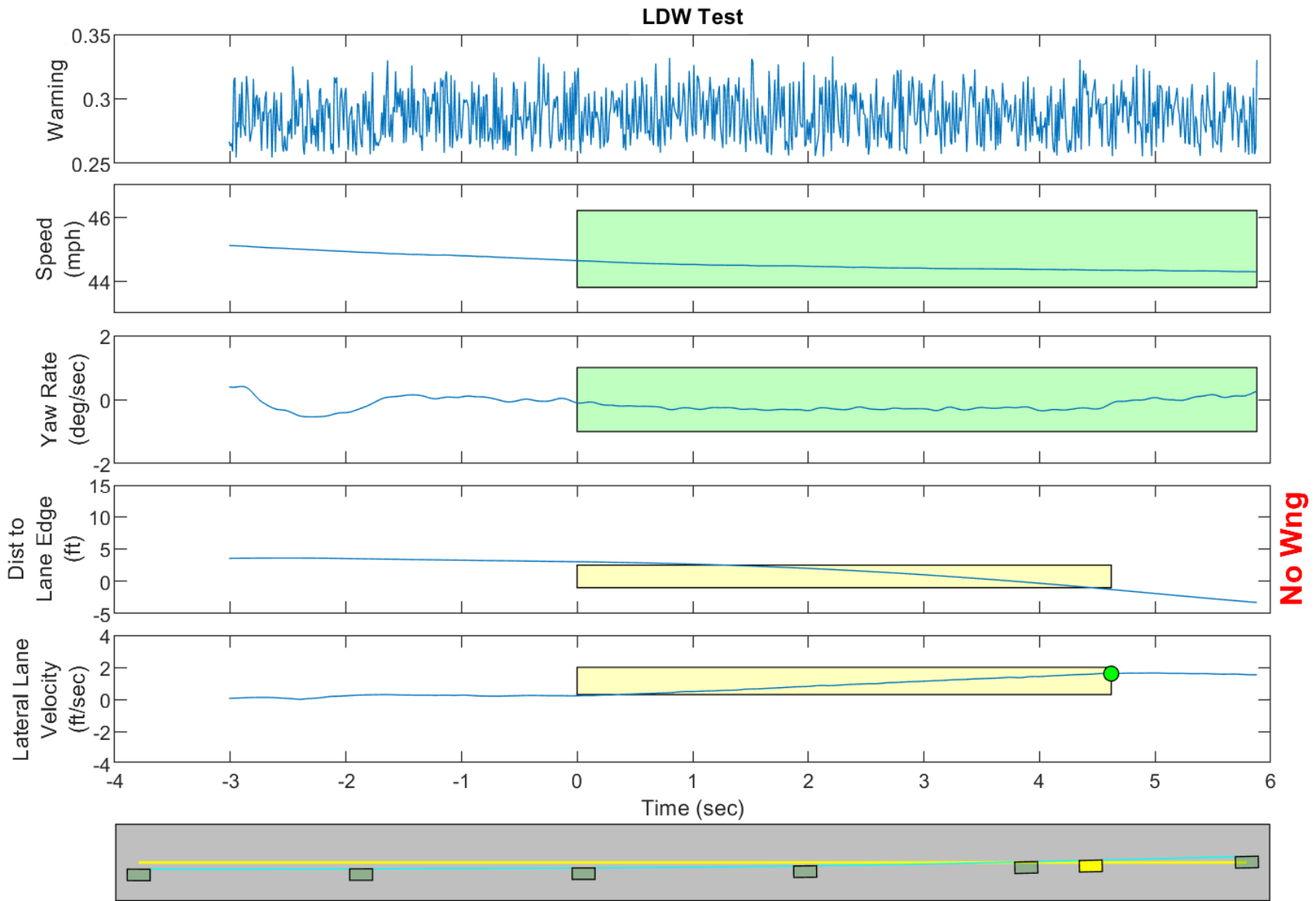

GPS Fix Type: RTK Fixed

Figure D2. Example Time History for Lane Departure Warning Test, Failing, No Warning Issued

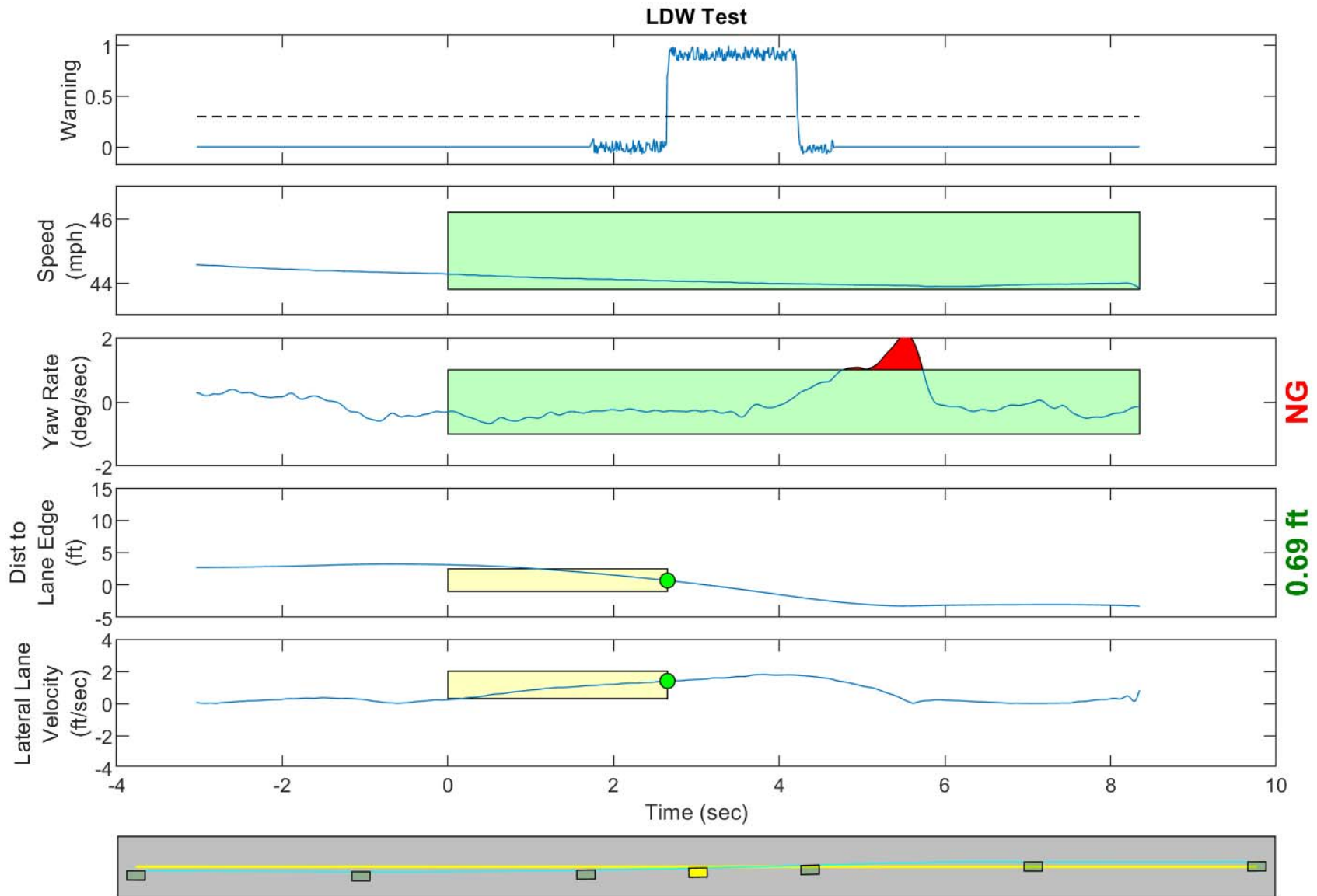

GPS Fix Type: RTK Fixed

Figure D3. Example Time History for Lane Departure Warning Test, Invalid Run Due to Subject Vehicle Yaw Rate

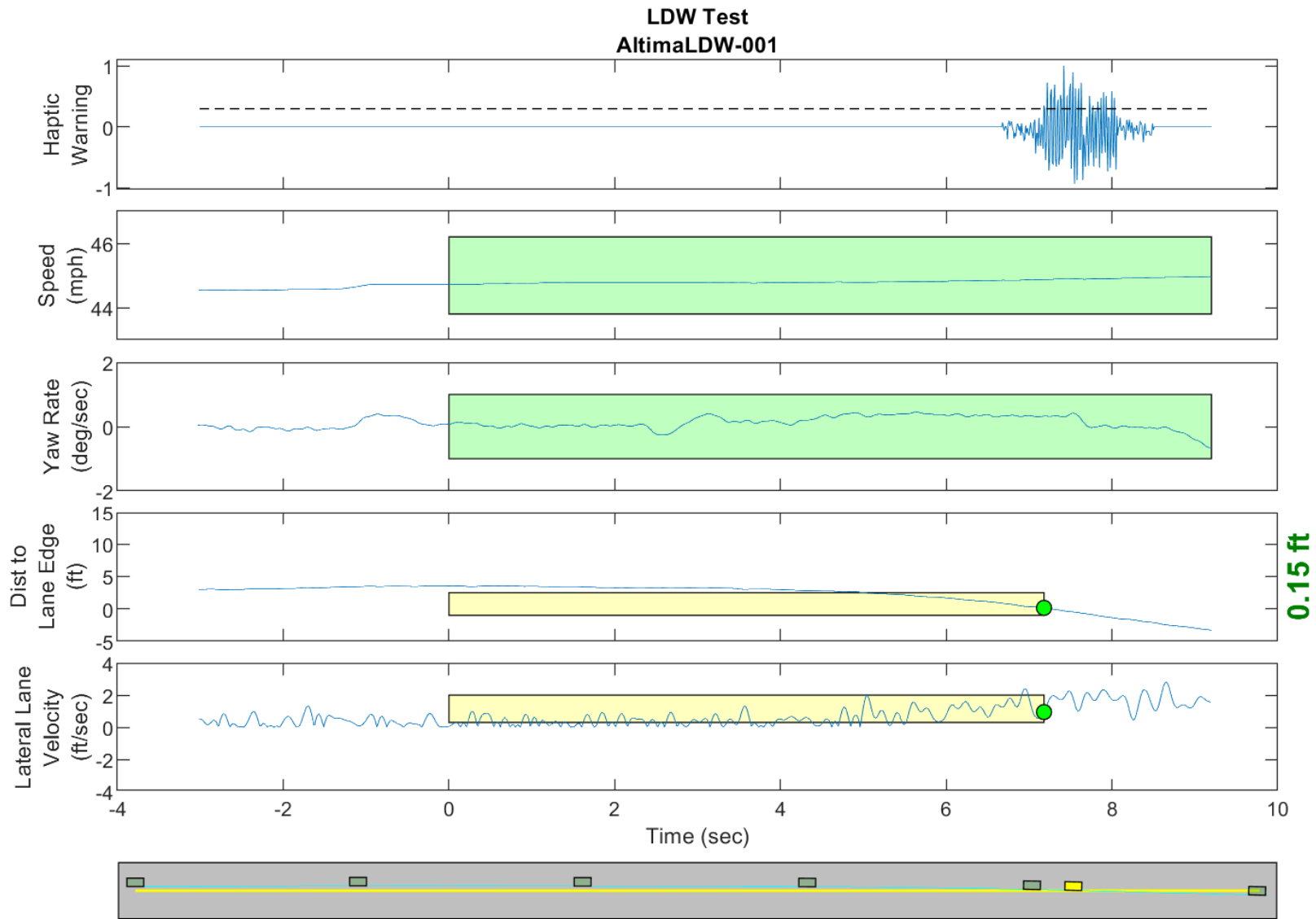

GPS Fix Type: RTK Fixed

Figure D4. Time History for Run 01, Botts Dots, Right Departure, Haptic Warning

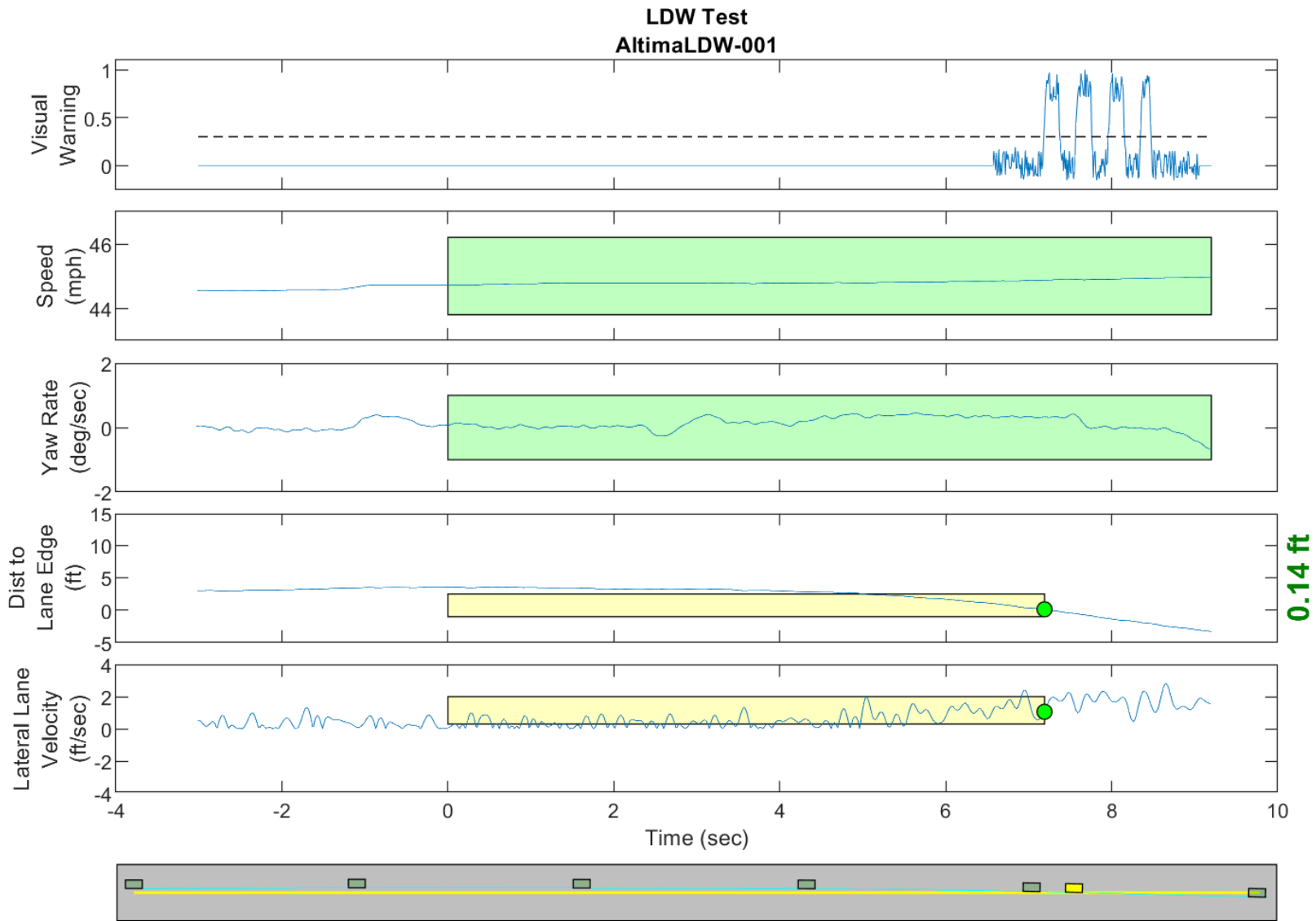

GPS Fix Type: RTK Fixed

Figure D5. Time History for Run 01, Botts Dots, Right Departure, Visual Warning

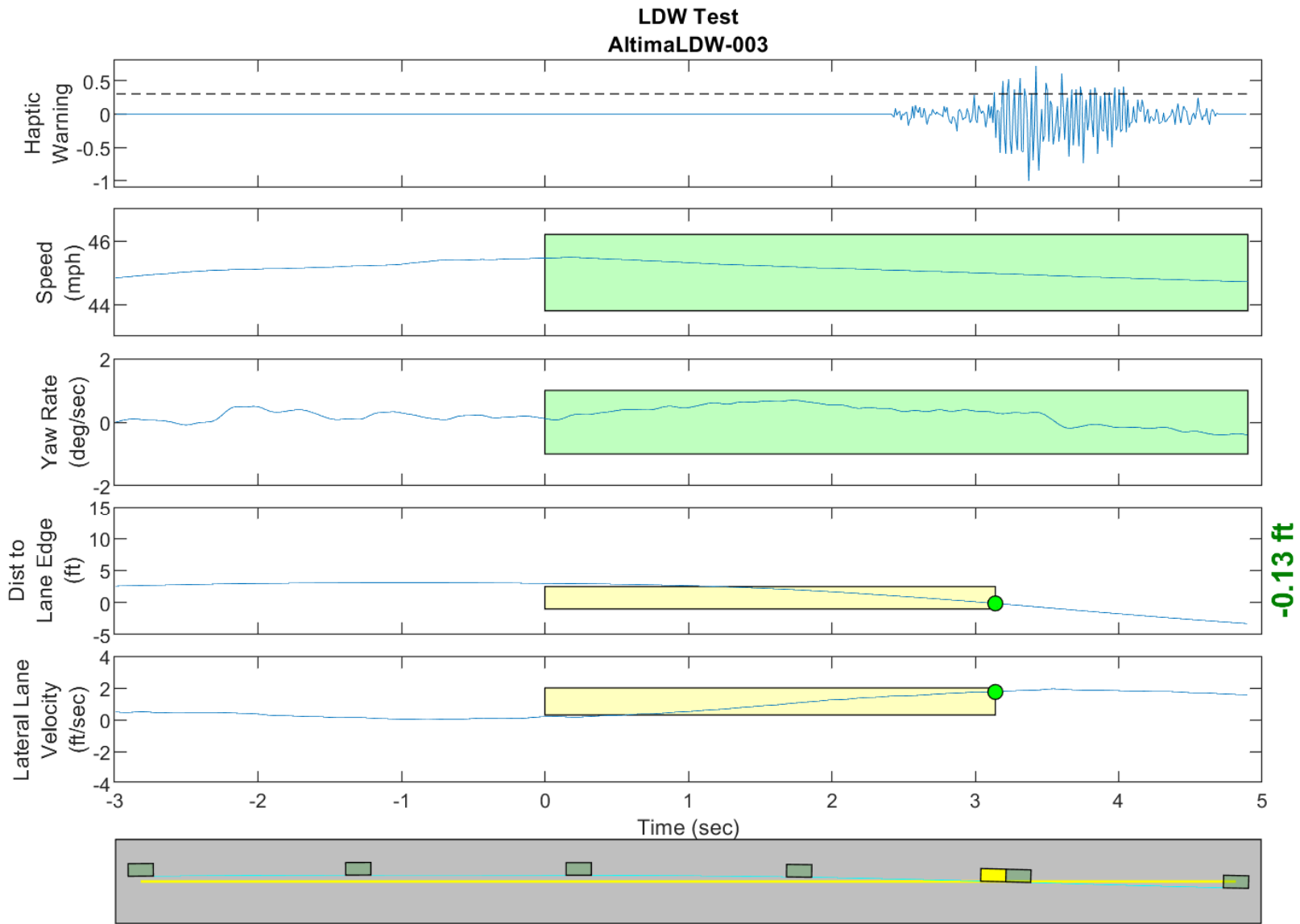

GPS Fix Type: RTK Fixed

Figure D6. Time History for Run 03, Botts Dots, Right Departure, Haptic Warning

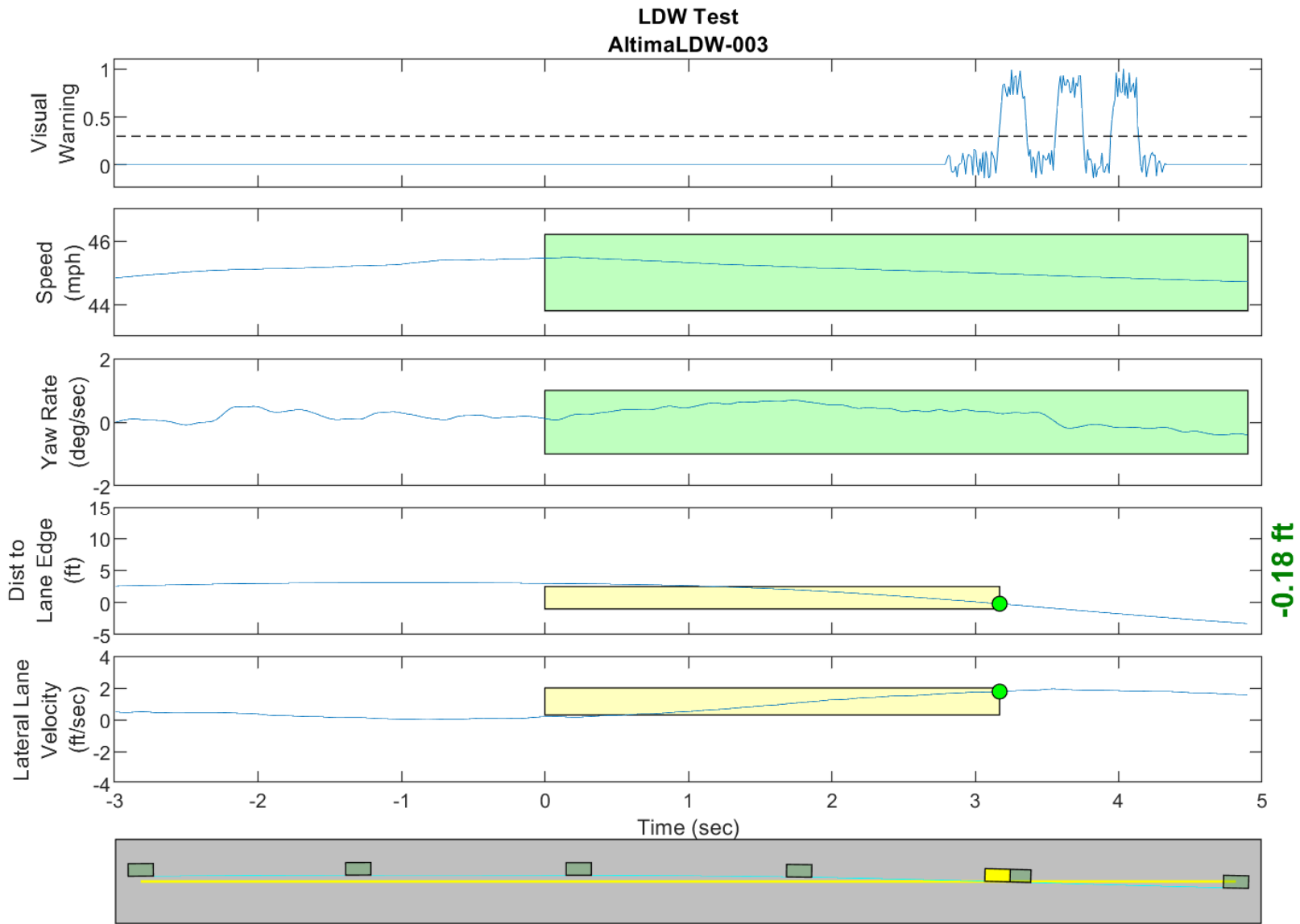

GPS Fix Type: RTK Fixed

Figure D7. Time History for Run 03, Botts Dots, Right Departure, Visual Warning

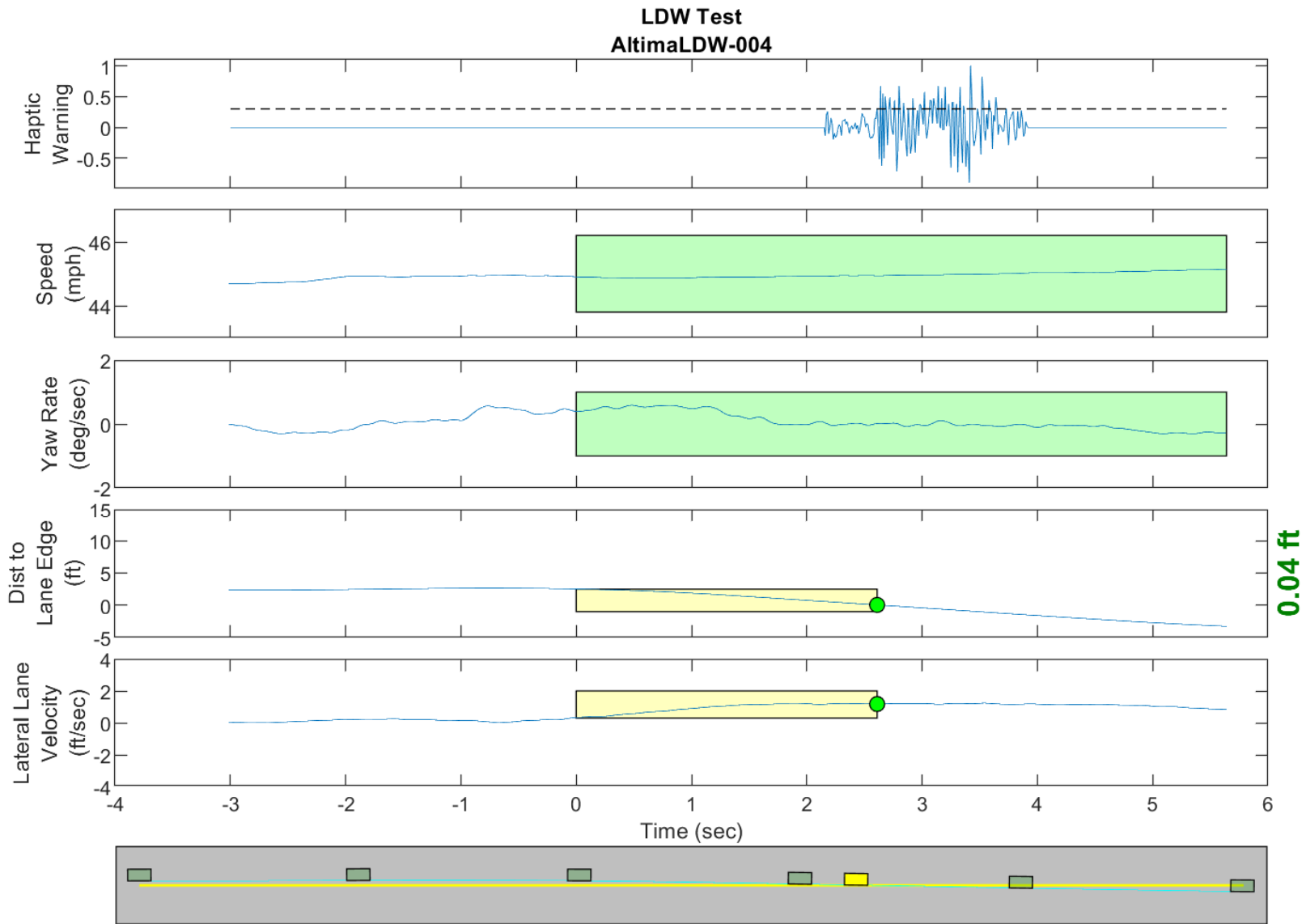

GPS Fix Type: RTK Fixed

Figure D8. Time History for Run 04, Botts Dots, Right Departure, Haptic Warning

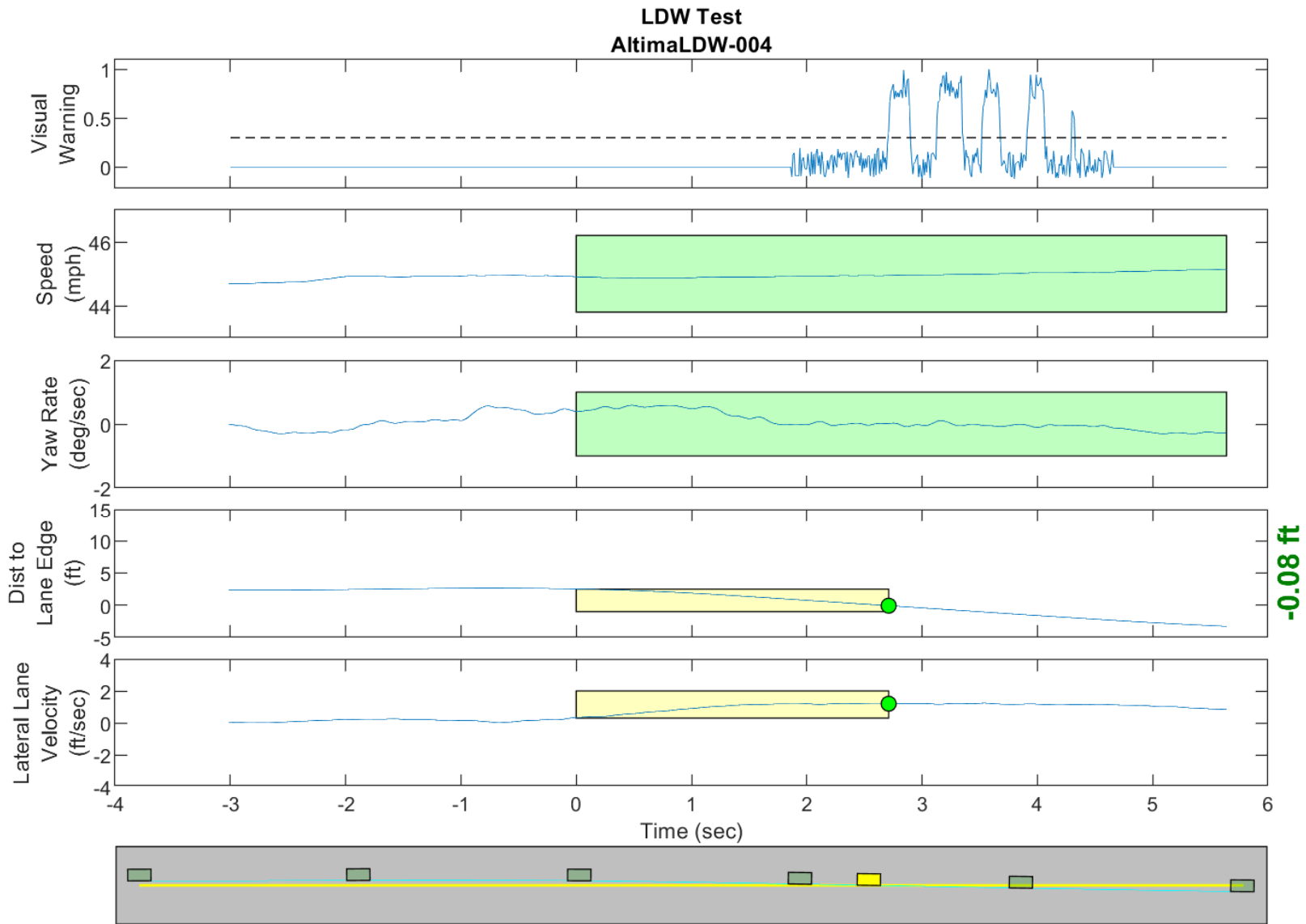

GPS Fix Type: RTK Fixed

Figure D9. Time History for Run 04, Botts Dots, Right Departure, Visual Warning

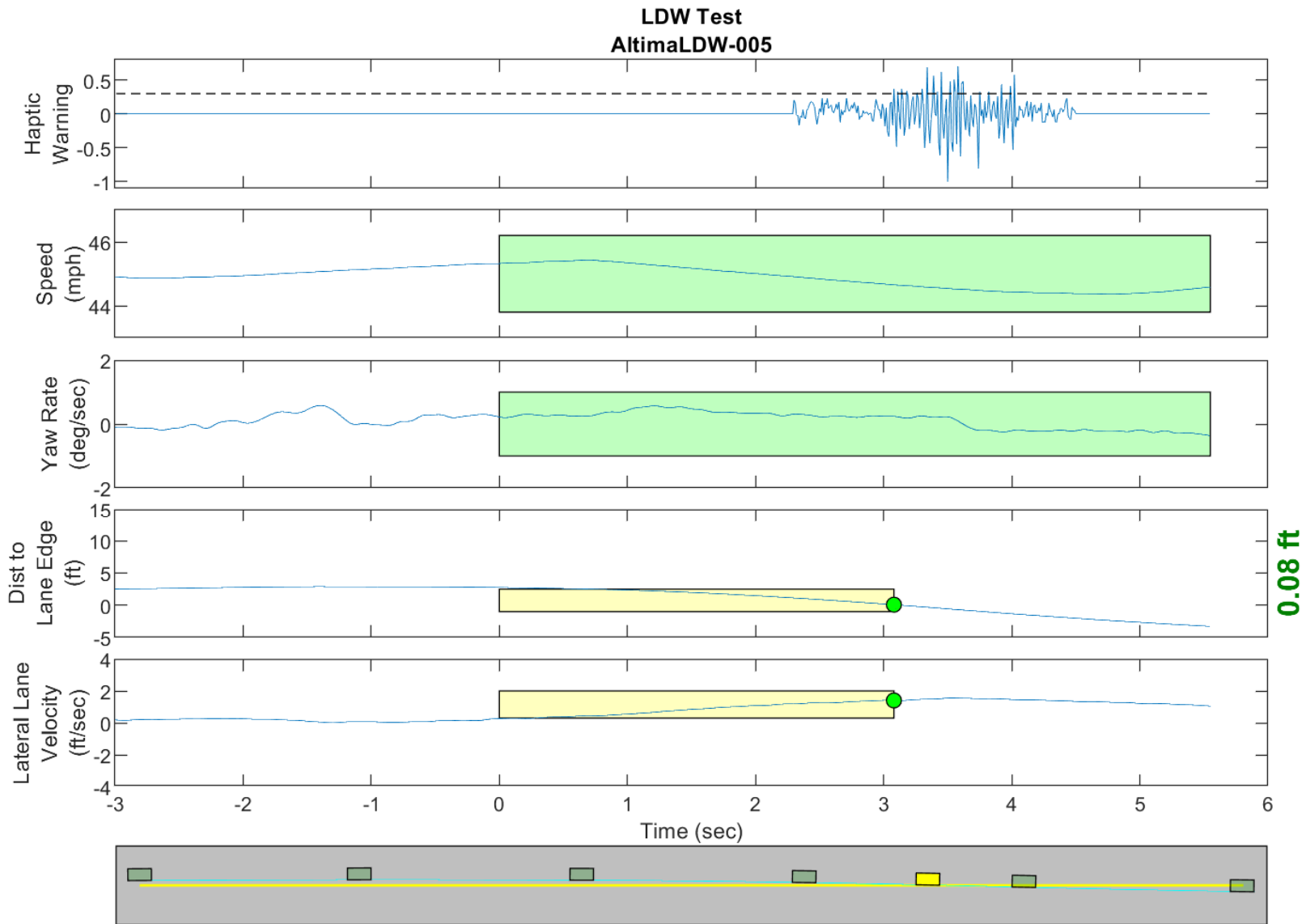

GPS Fix Type: RTK Fixed

Figure D10. Time History for Run 05, Botts Dots, Right Departure, Haptic Warning

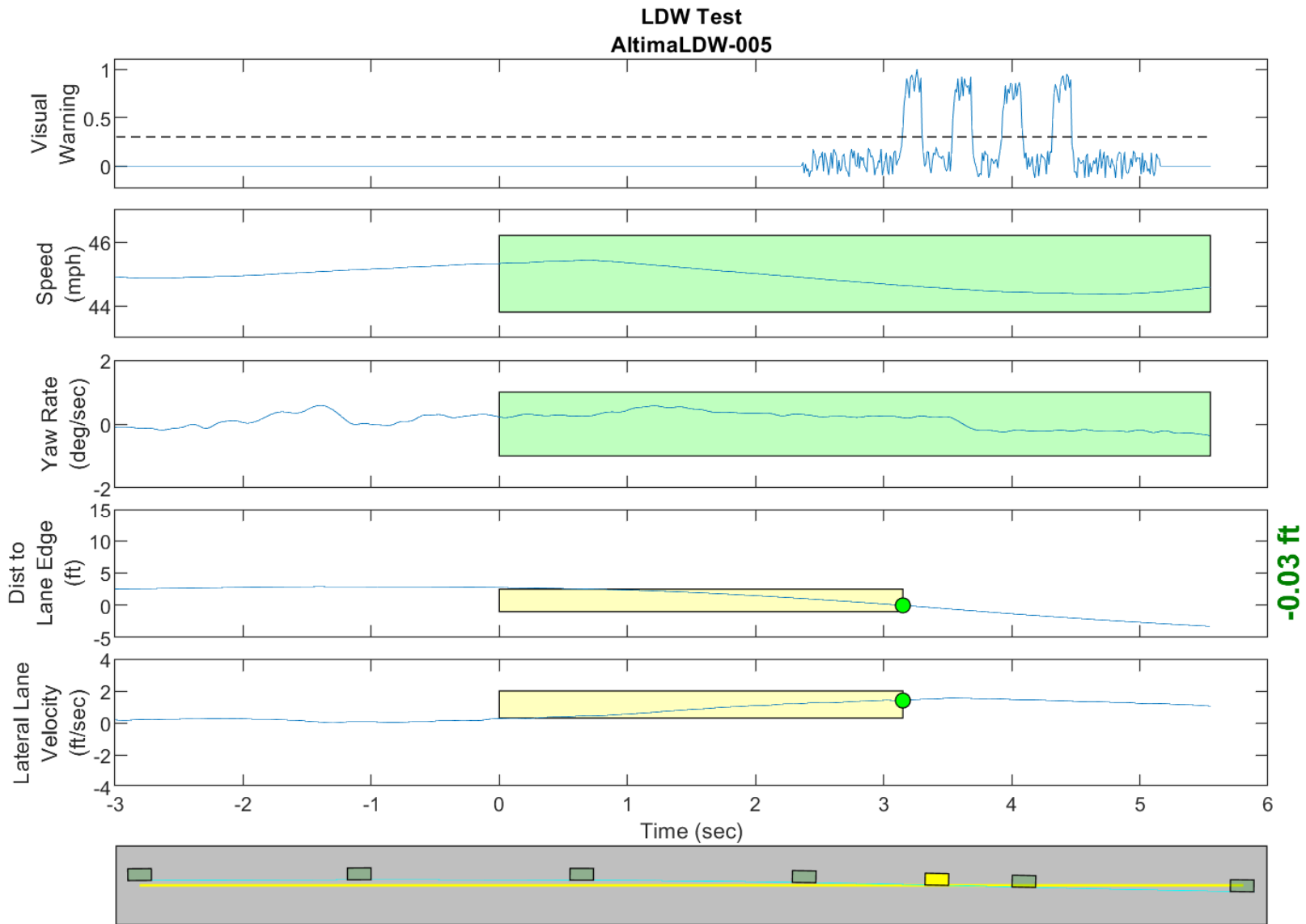

GPS Fix Type: RTK Fixed

Figure D11. Time History for Run 05, Botts Dots, Right Departure, Visual Warning

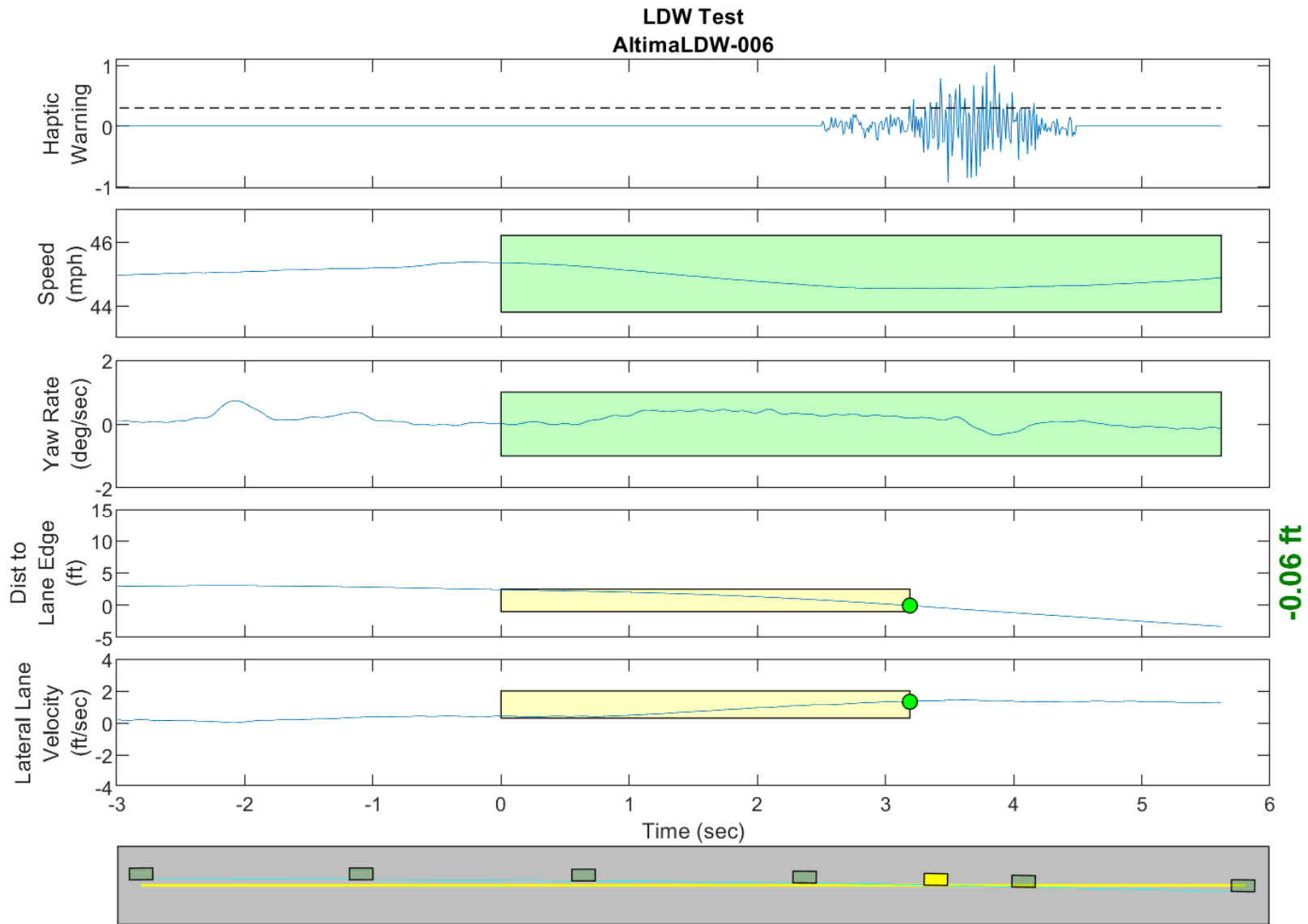

GPS Fix Type: RTK Fixed

Figure D12. Time History for Run 06, Botts Dots, Right Departure, Haptic Warning

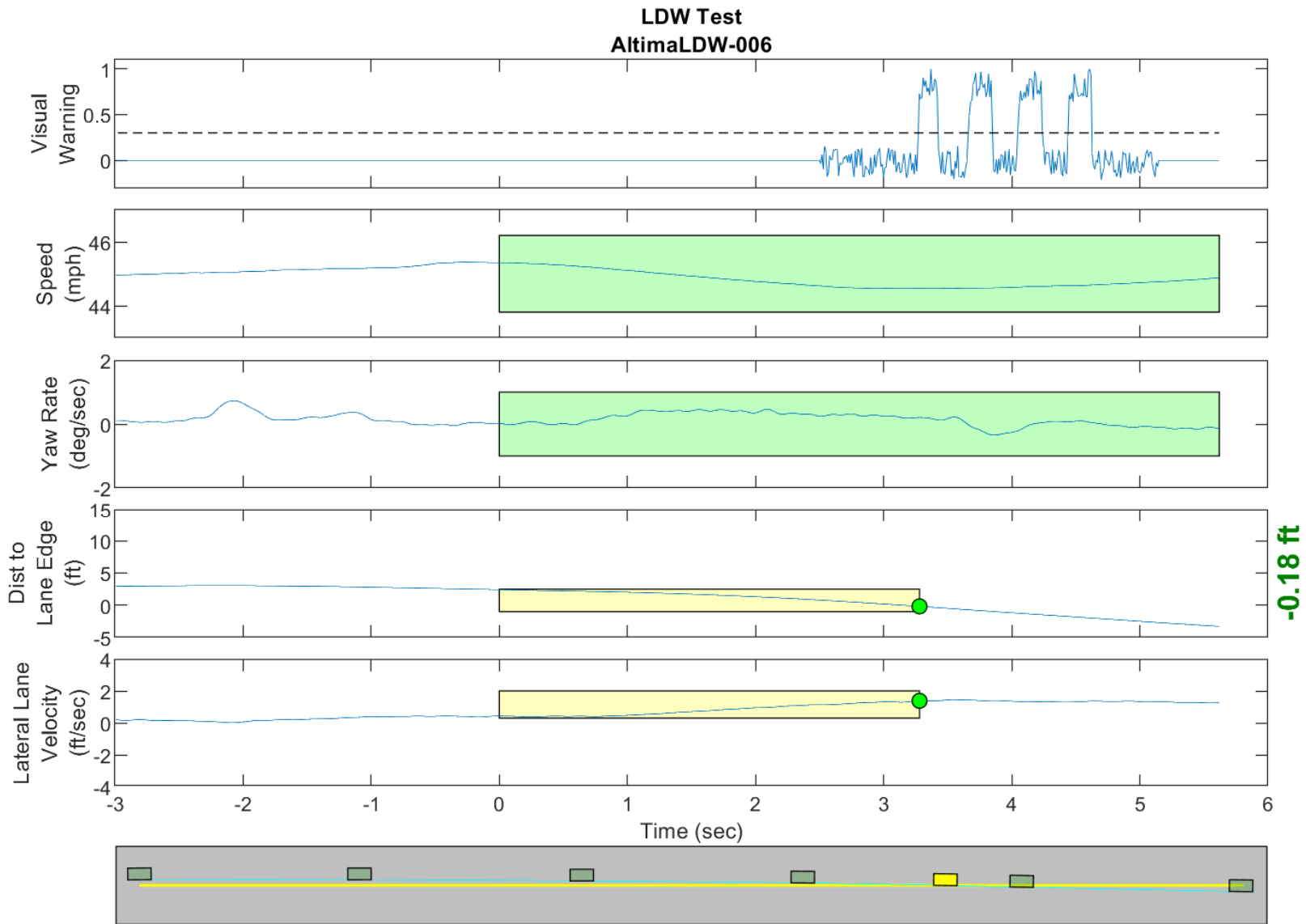

GPS Fix Type: RTK Fixed

Figure D13. Time History for Run 06, Botts Dots, Right Departure, Visual Warning

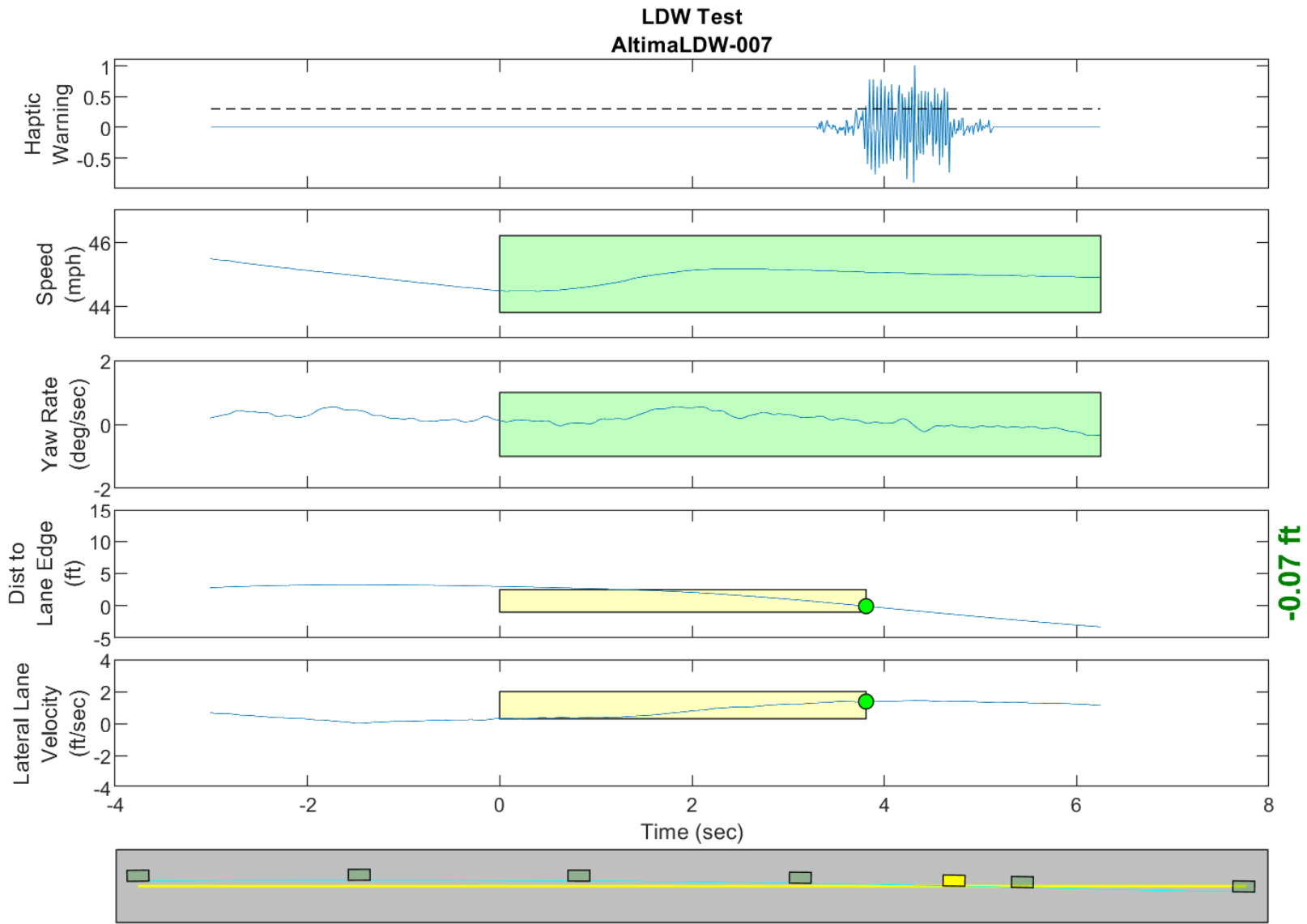

GPS Fix Type: RTK Fixed

Figure D14. Time History for Run 07, Botts Dots, Right Departure, Haptic Warning

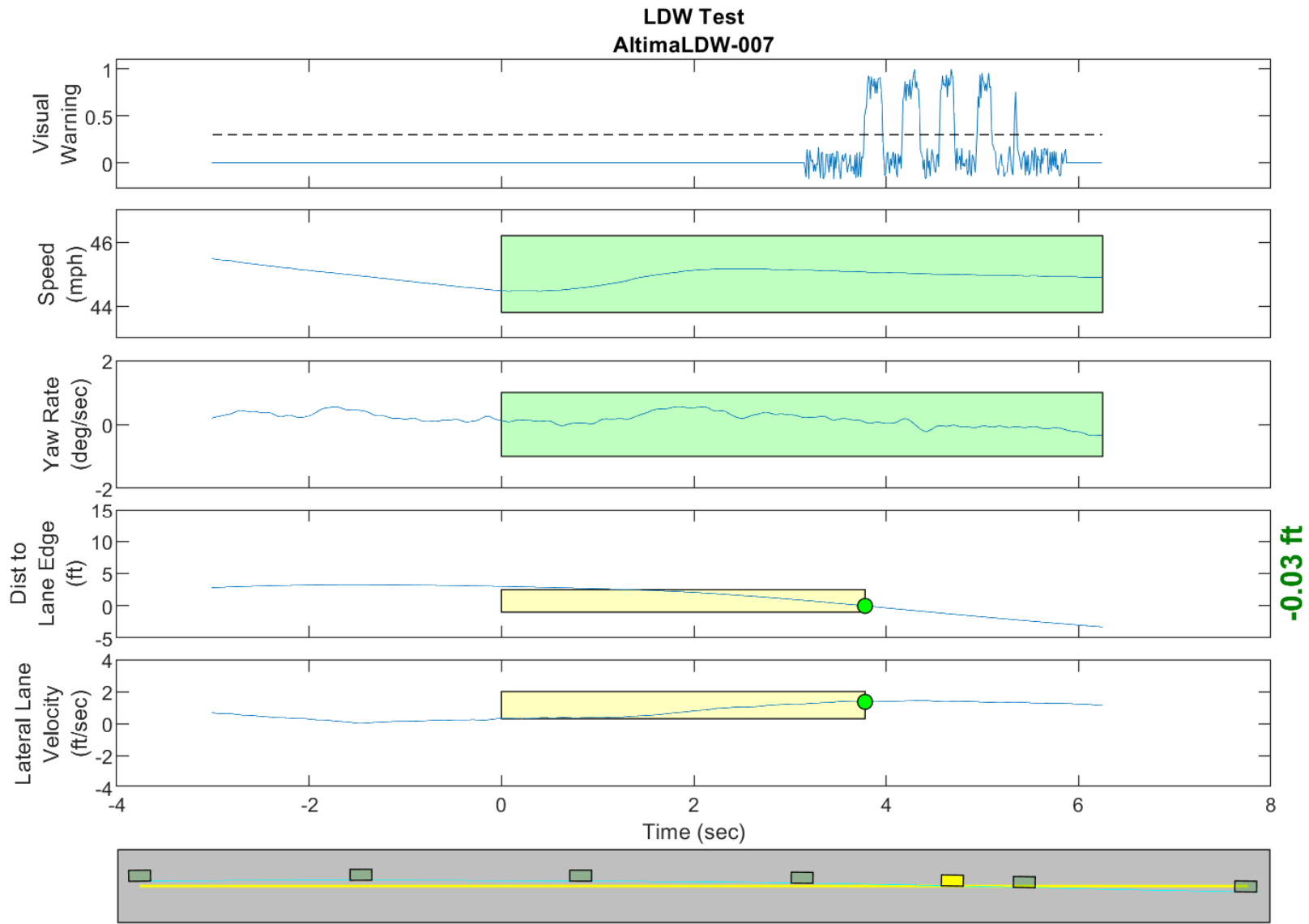

GPS Fix Type: RTK Fixed

Figure D15. Time History for Run 07, Botts Dots, Right Departure, Visual Warning

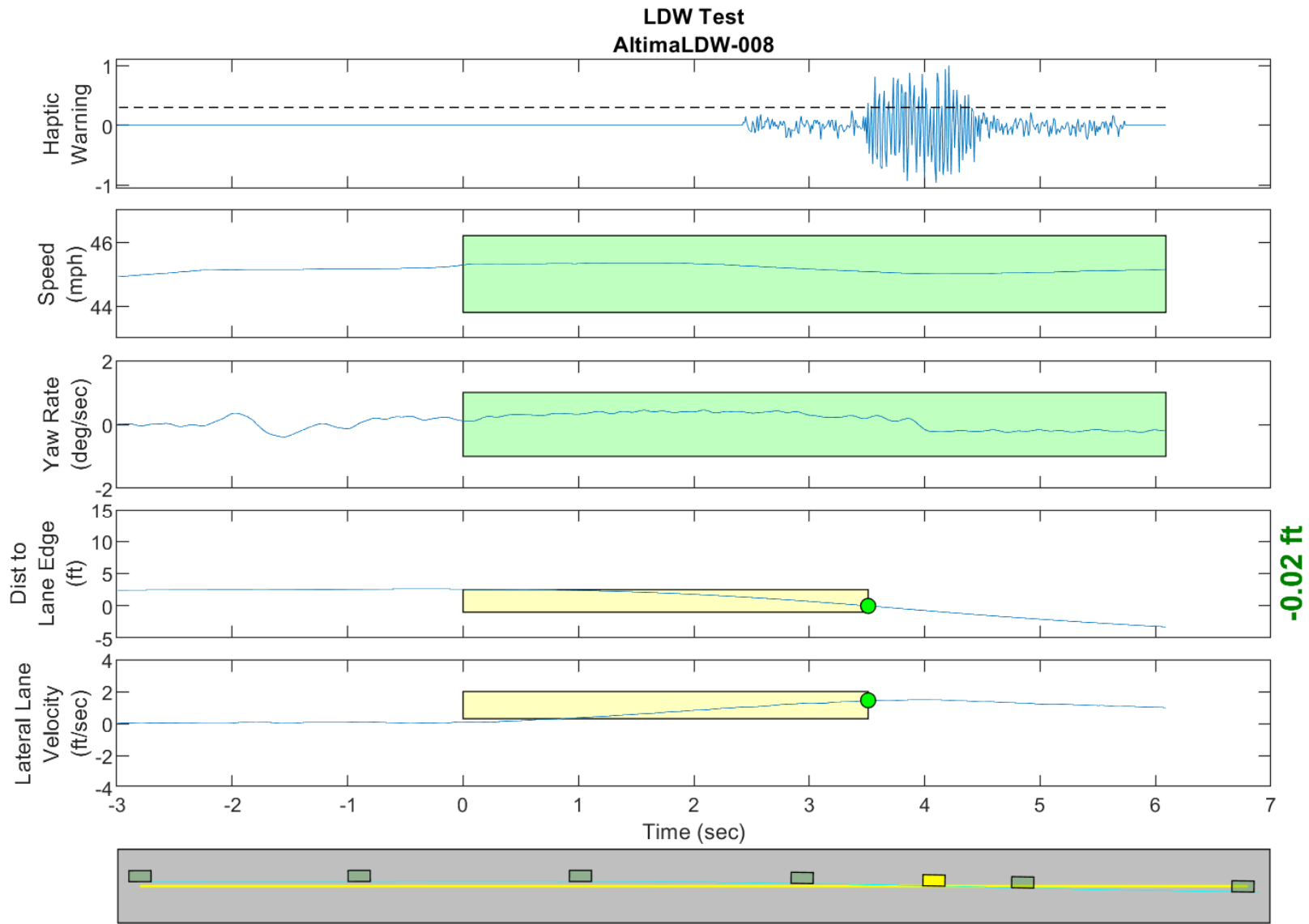

GPS Fix Type: RTK Fixed

Figure D16. Time History for Run 08, Botts Dots, Right Departure, Haptic Warning

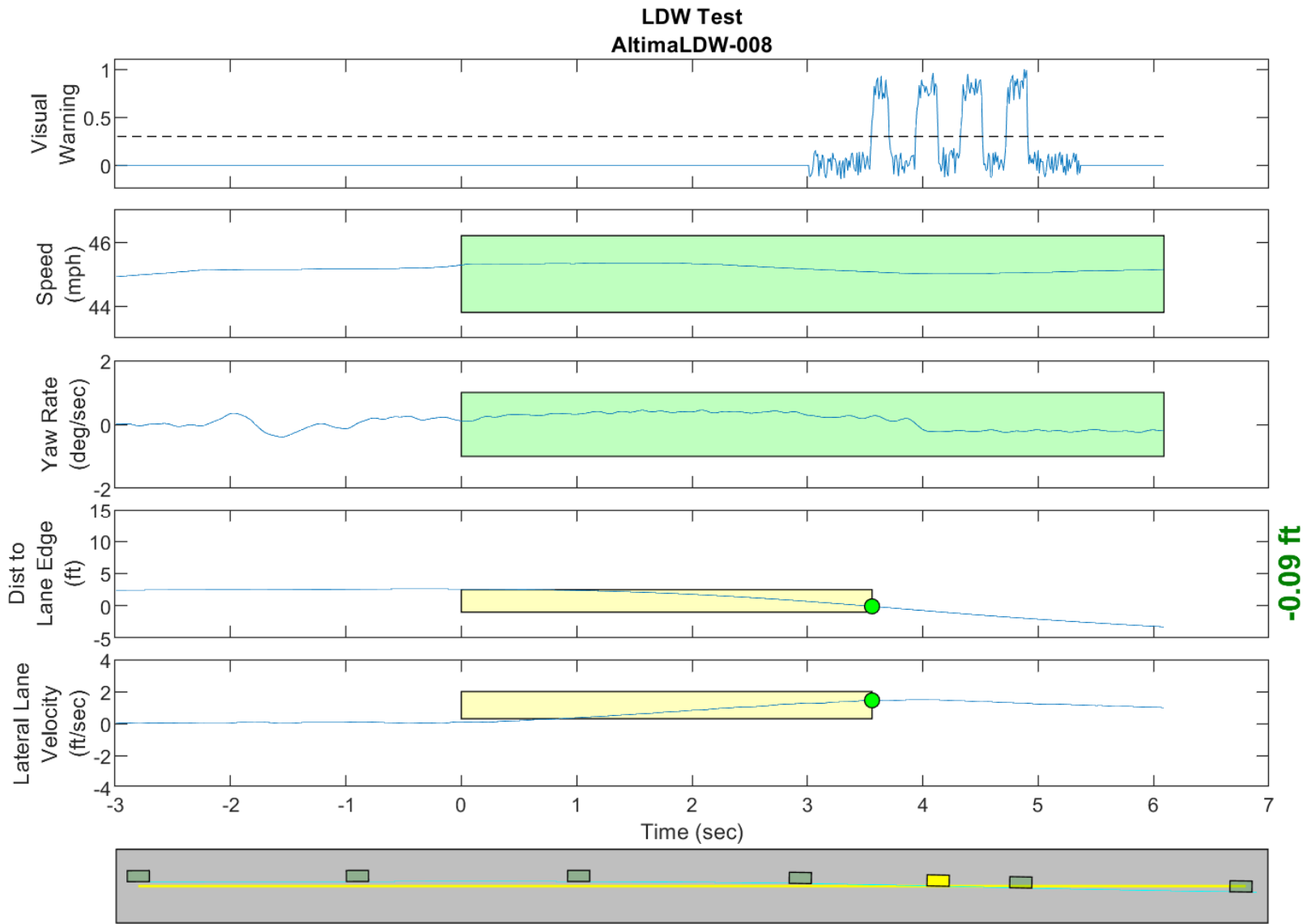

GPS Fix Type: RTK Fixed

Figure D17. Time History for Run 08, Botts Dots, Right Departure, Visual Warning

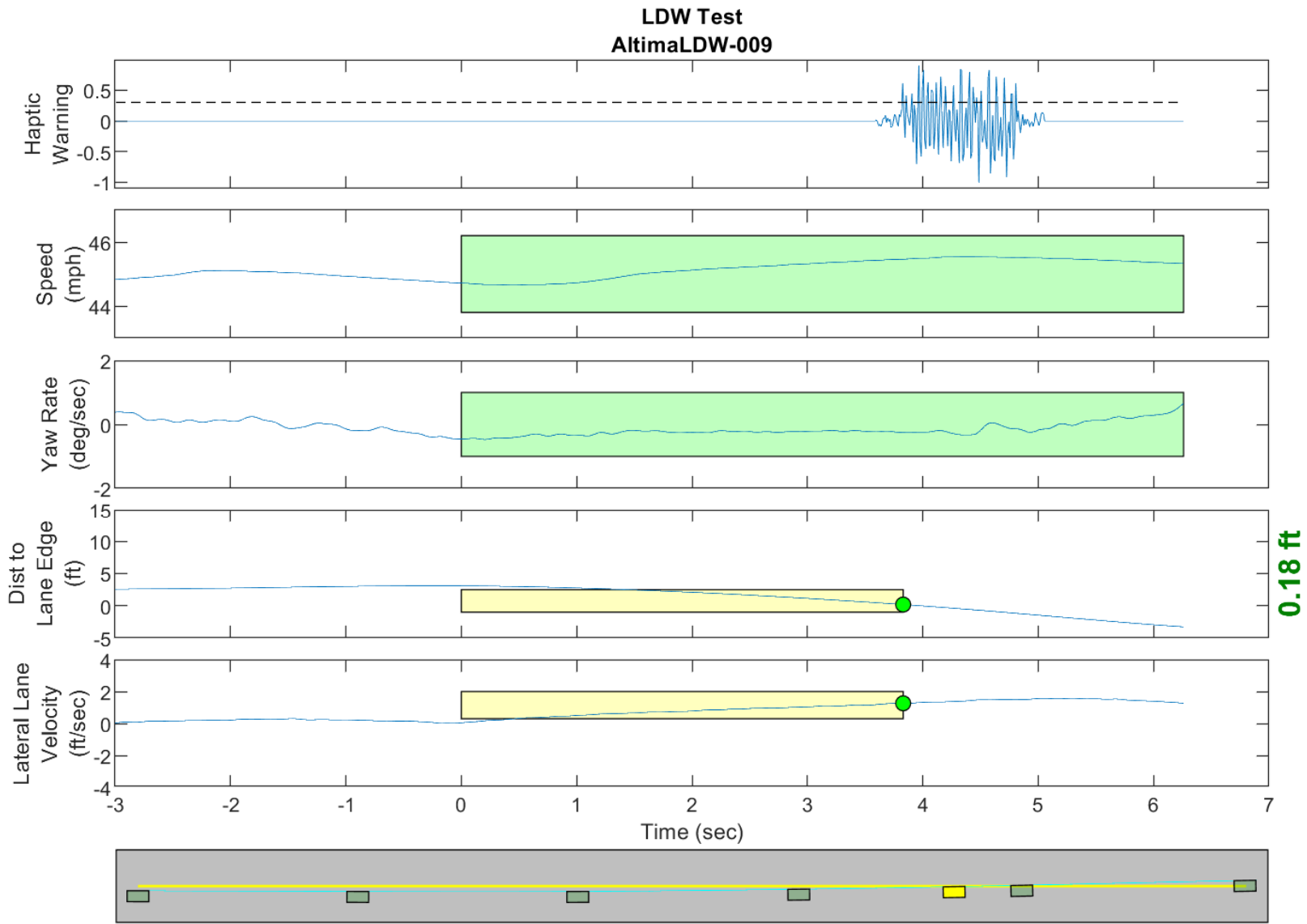

GPS Fix Type: RTK Fixed

Figure D18. Time History for Run 09, Botts Dots, Left Departure, Haptic Warning

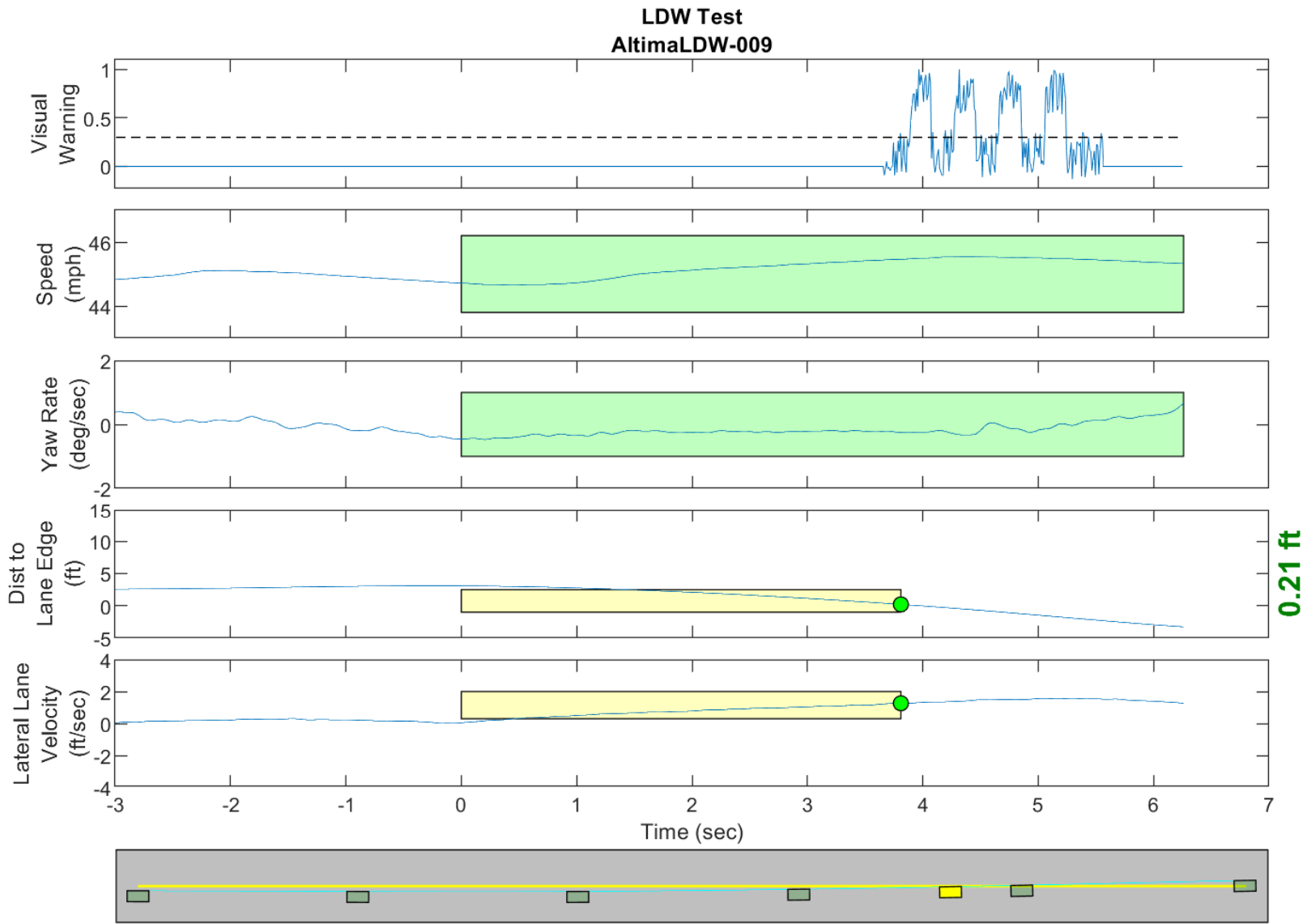

GPS Fix Type: RTK Fixed

Figure D19. Time History for Run 09, Botts Dots, Left Departure, Visual Warning

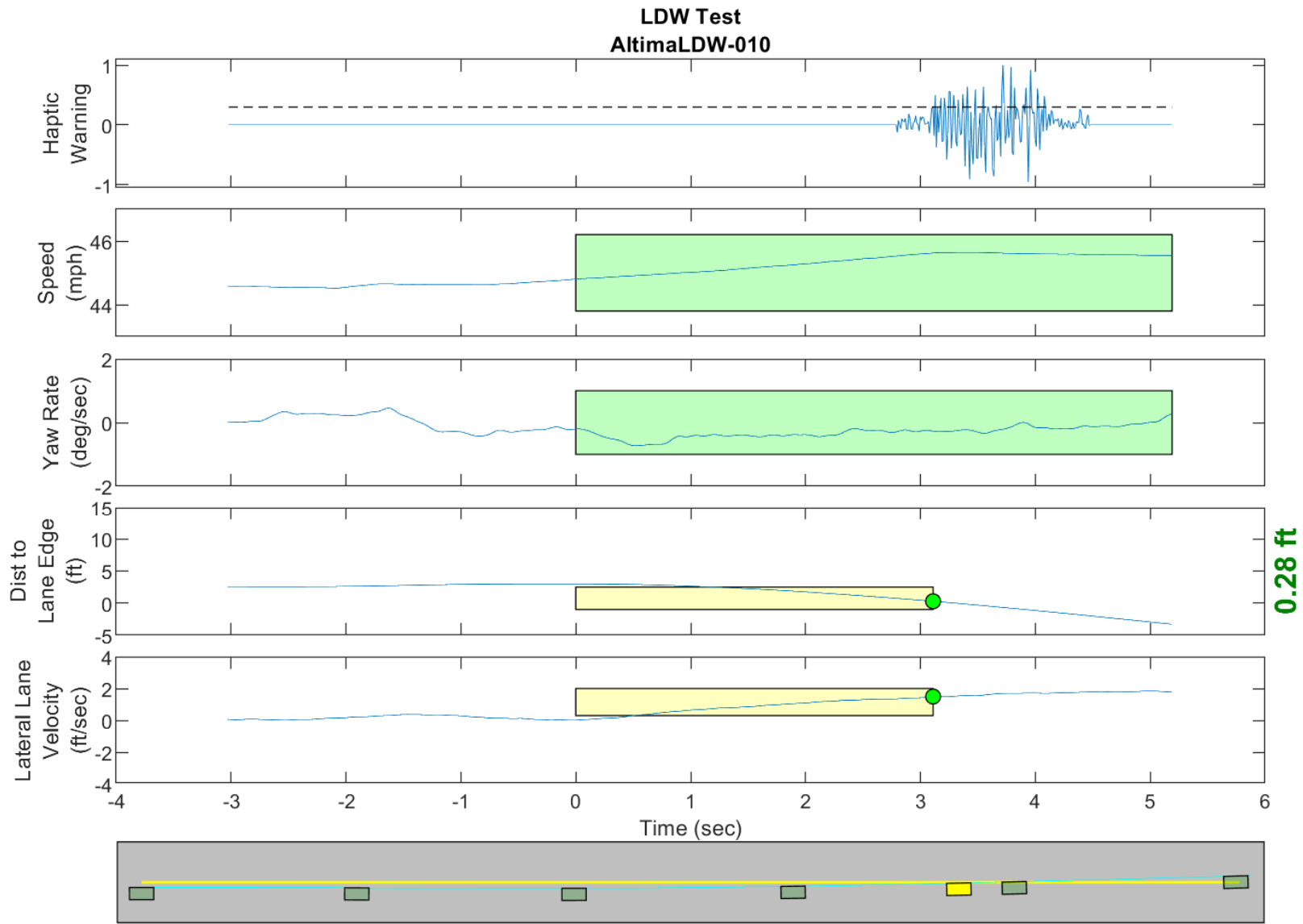

GPS Fix Type: RTK Fixed

Figure D20. Time History for Run 10, Botts Dots, Left Departure, Haptic Warning

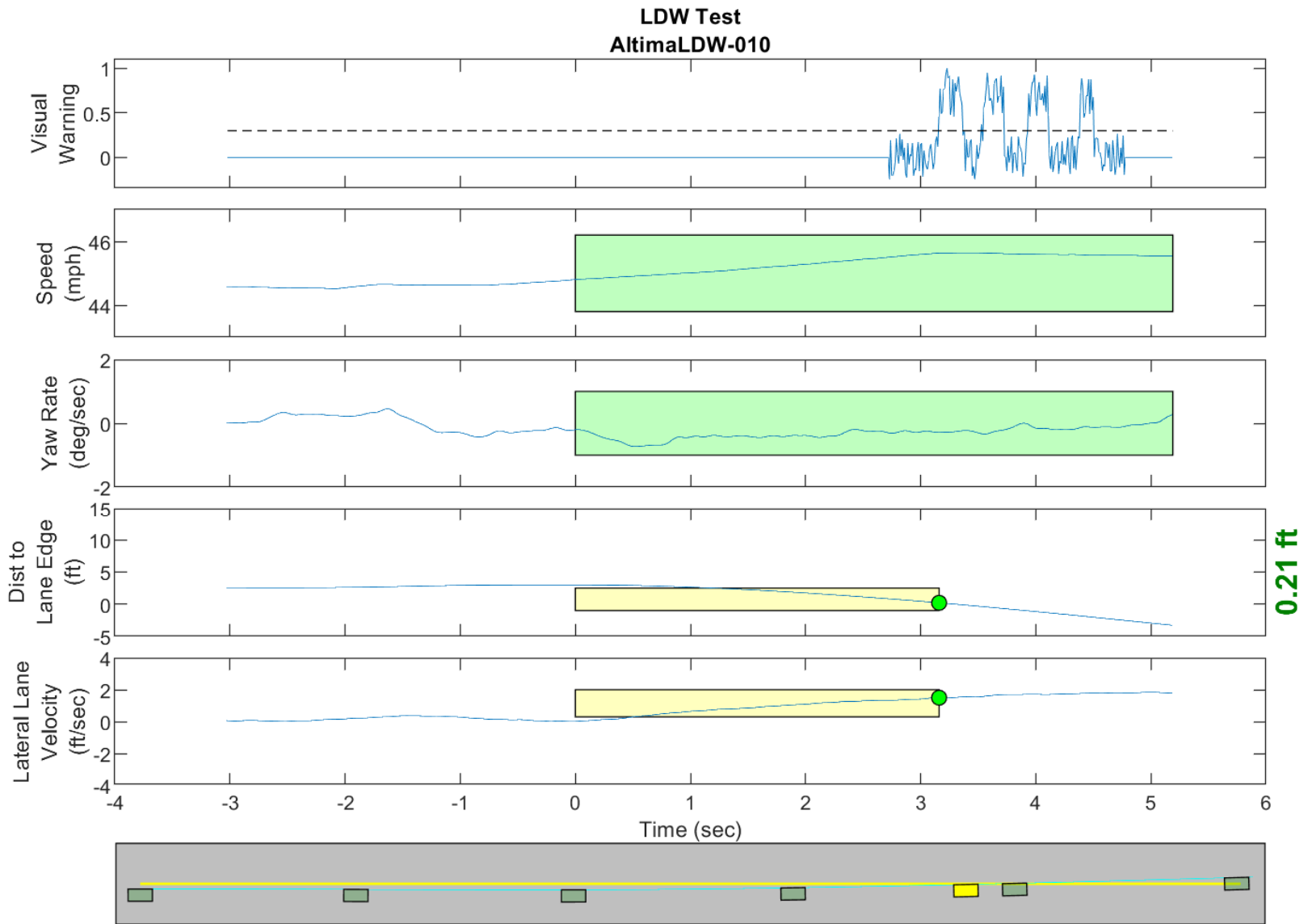

GPS Fix Type: RTK Fixed

Figure D21. Time History for Run 10, Botts Dots, Left Departure, Visual Warning

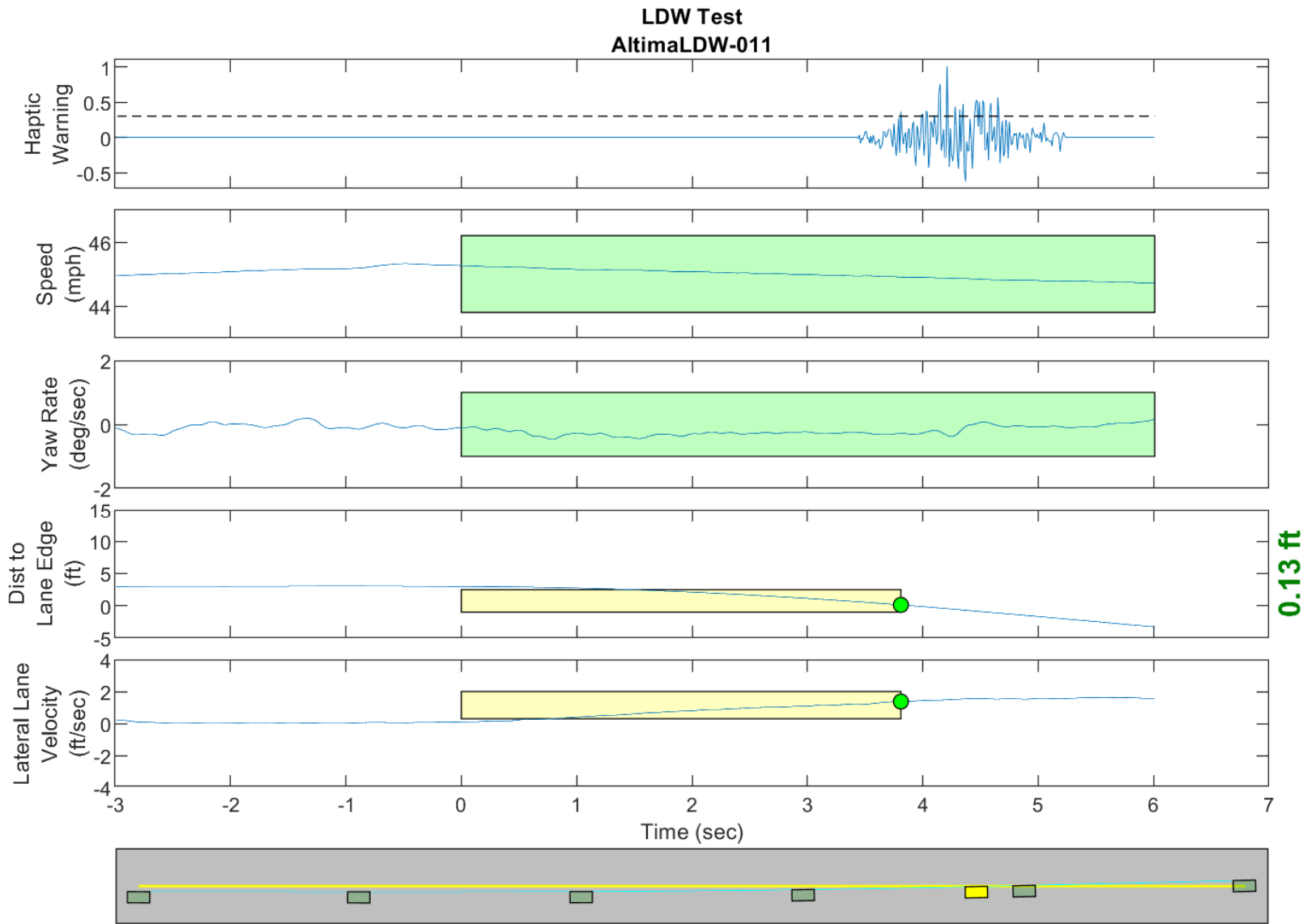

GPS Fix Type: RTK Fixed

Figure D22. Time History for Run 11, Botts Dots, Left Departure, Haptic Warning

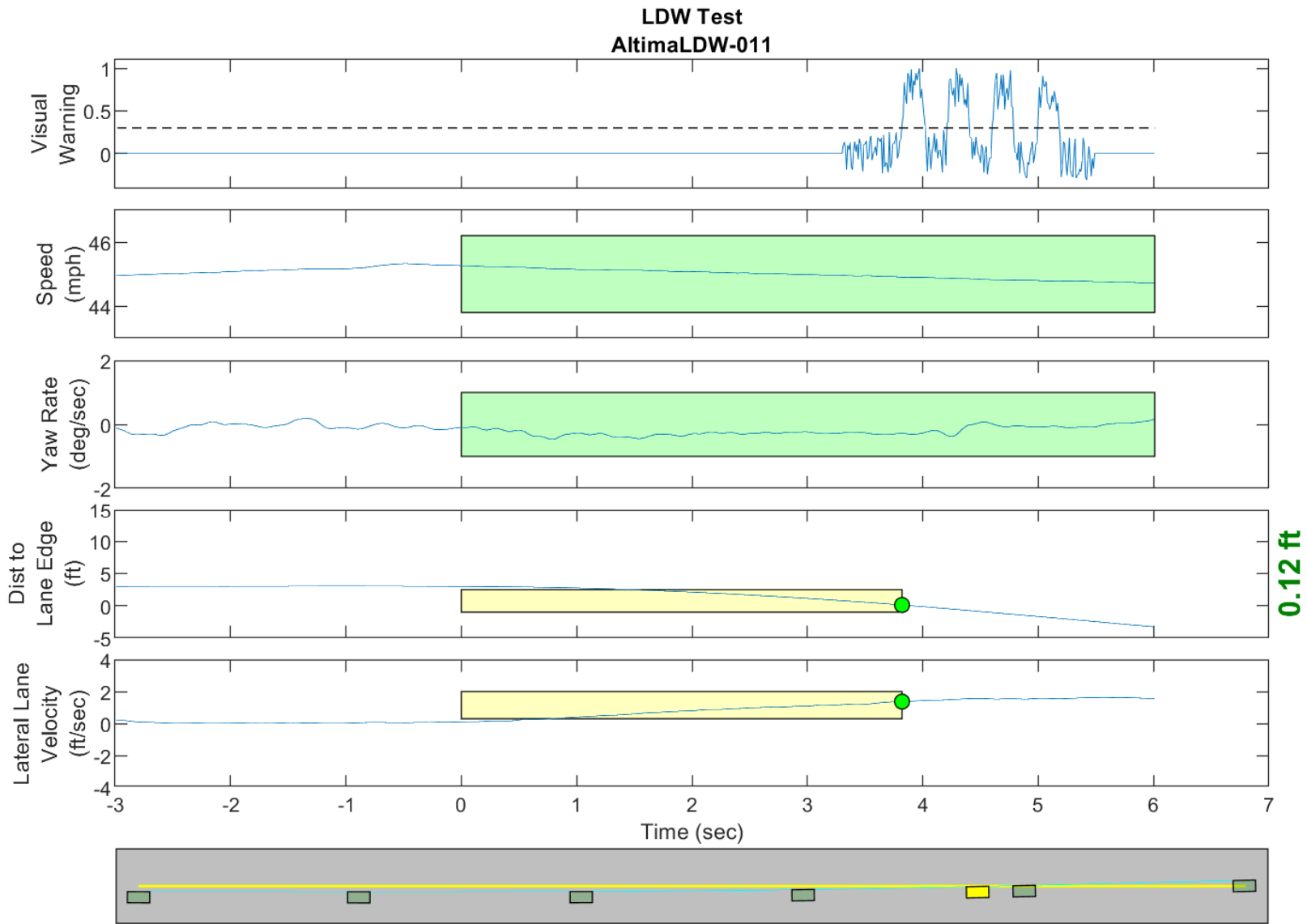

GPS Fix Type: RTK Fixed

Figure D23. Time History for Run 11, Botts Dots, Left Departure, Visual Warning

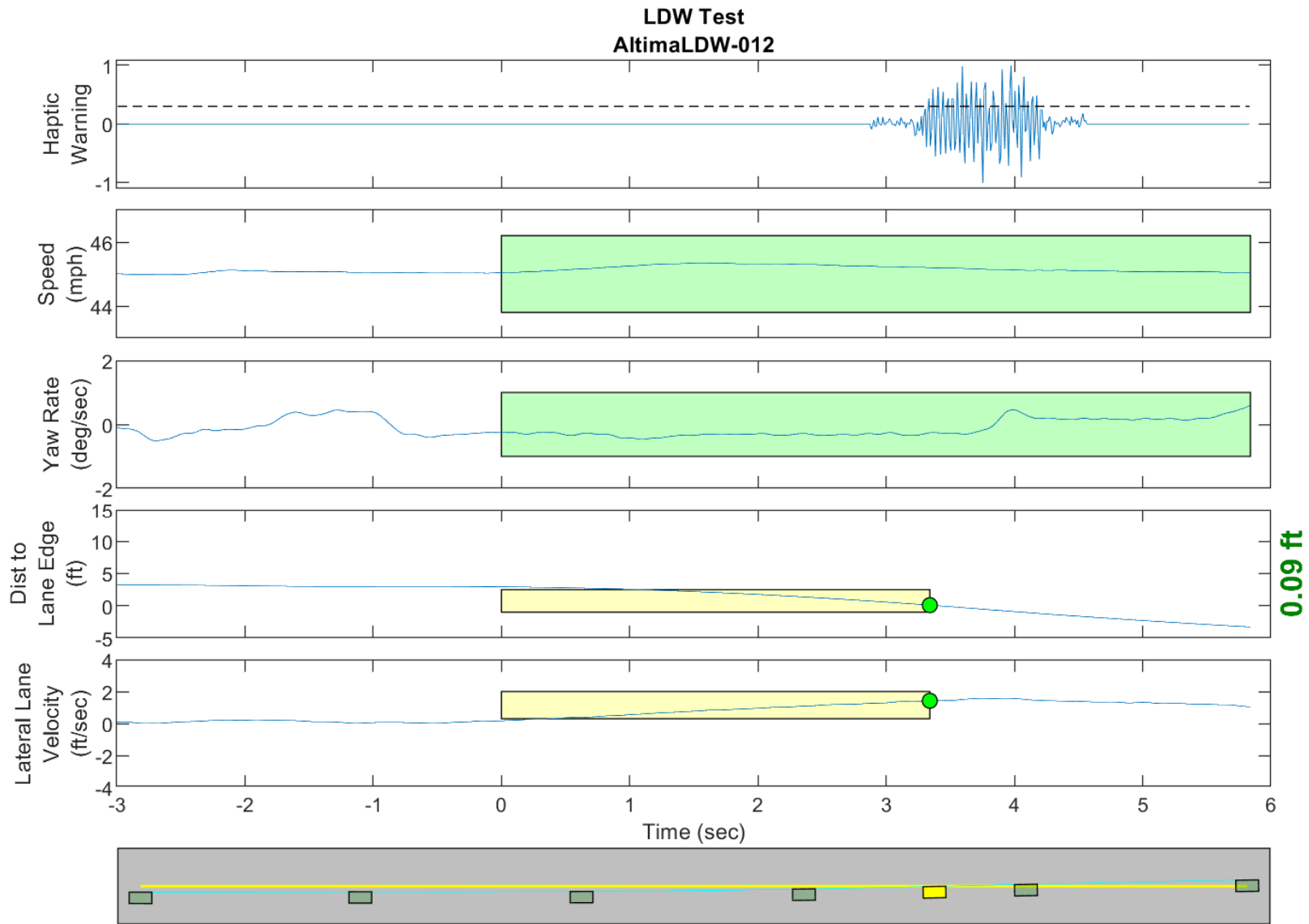

GPS Fix Type: RTK Fixed

Figure D24. Time History for Run 12, Botts Dots, Left Departure, Haptic Warning

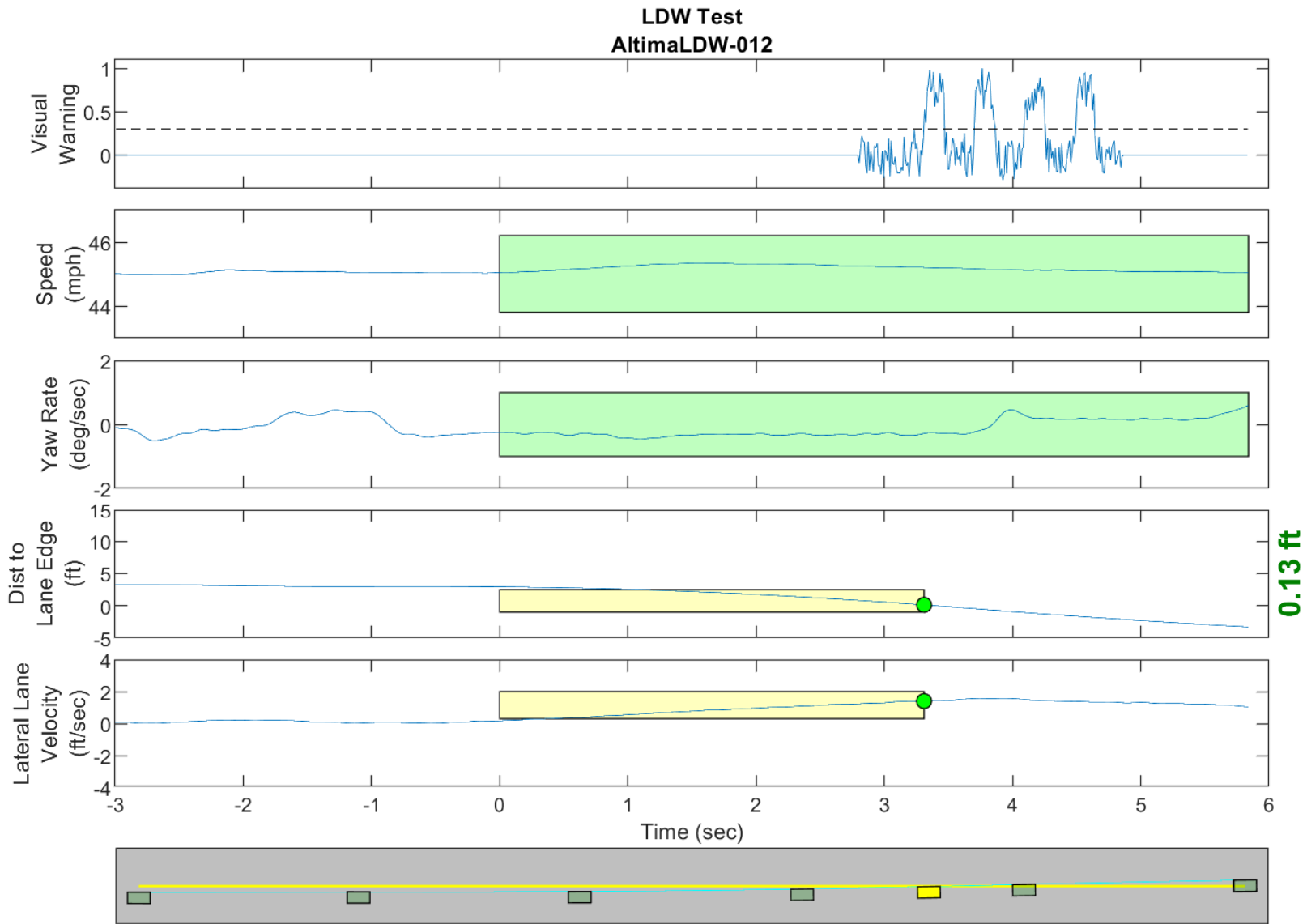

GPS Fix Type: RTK Fixed

Figure D25. Time History for Run 12, Botts Dots, Left Departure, Visual Warning

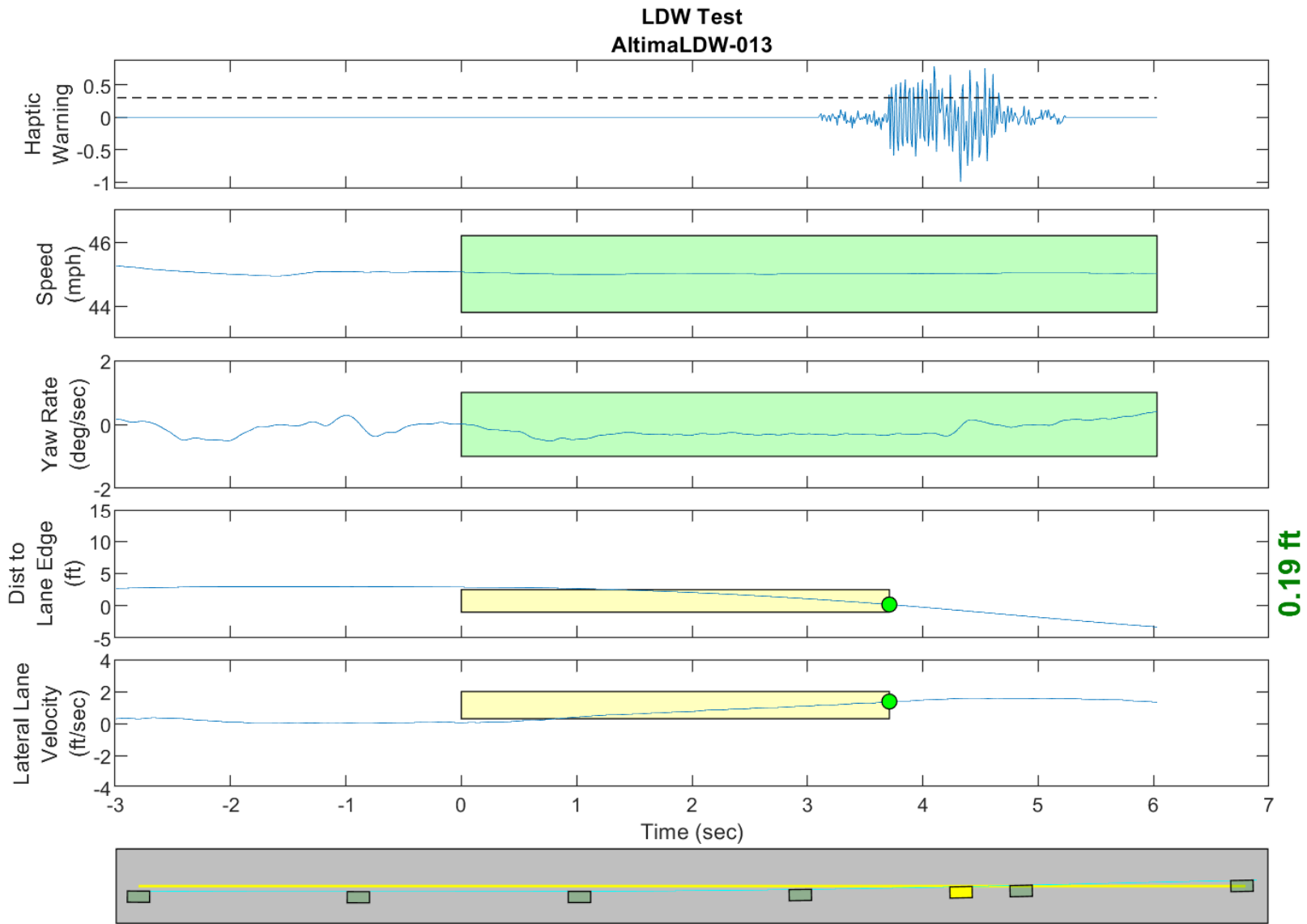

GPS Fix Type: RTK Fixed

Figure D26. Time History for Run 13, Botts Dots, Left Departure, Haptic Warning

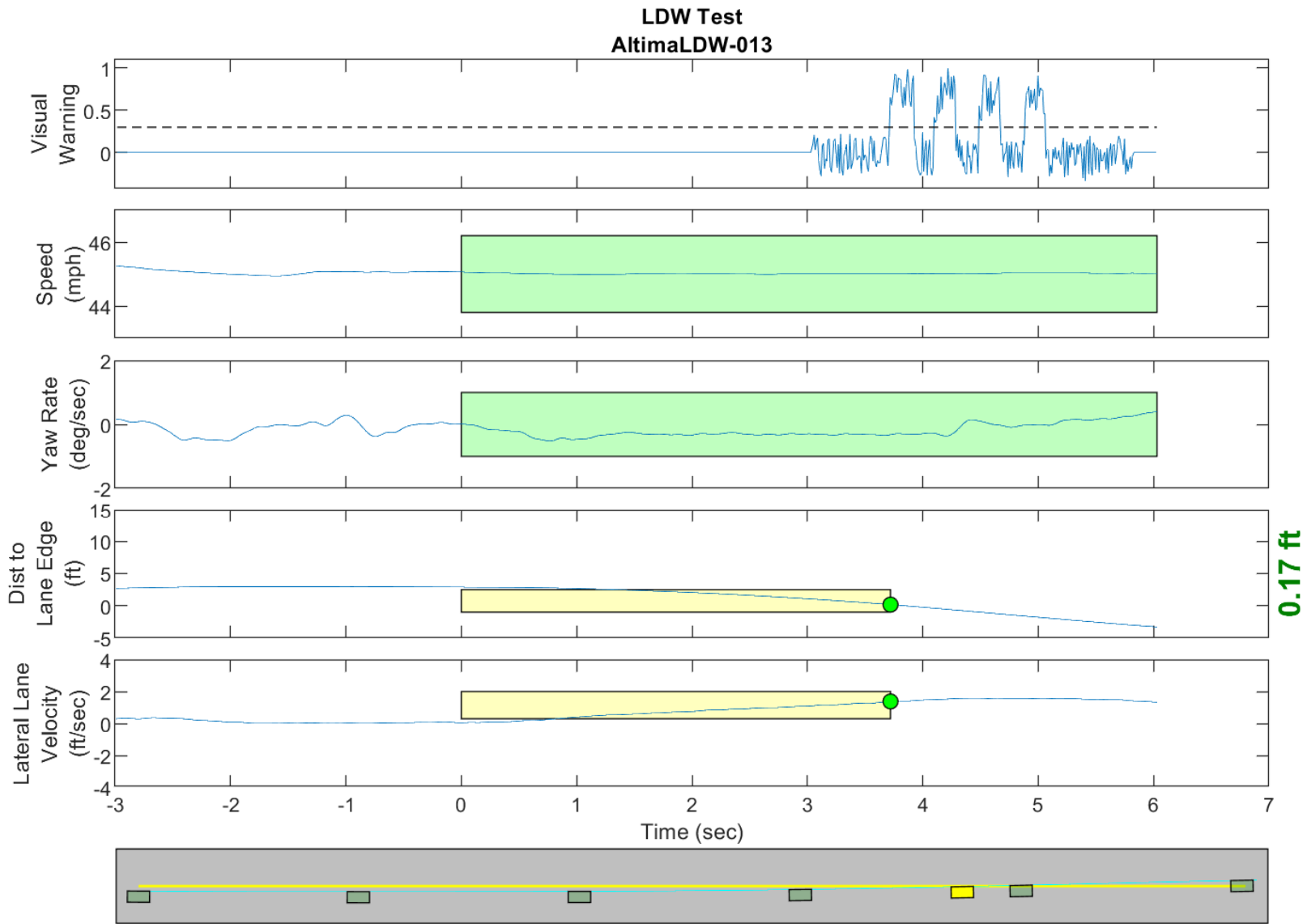

GPS Fix Type: RTK Fixed

Figure D27. Time History for Run 13, Botts Dots, Left Departure, Visual Warning

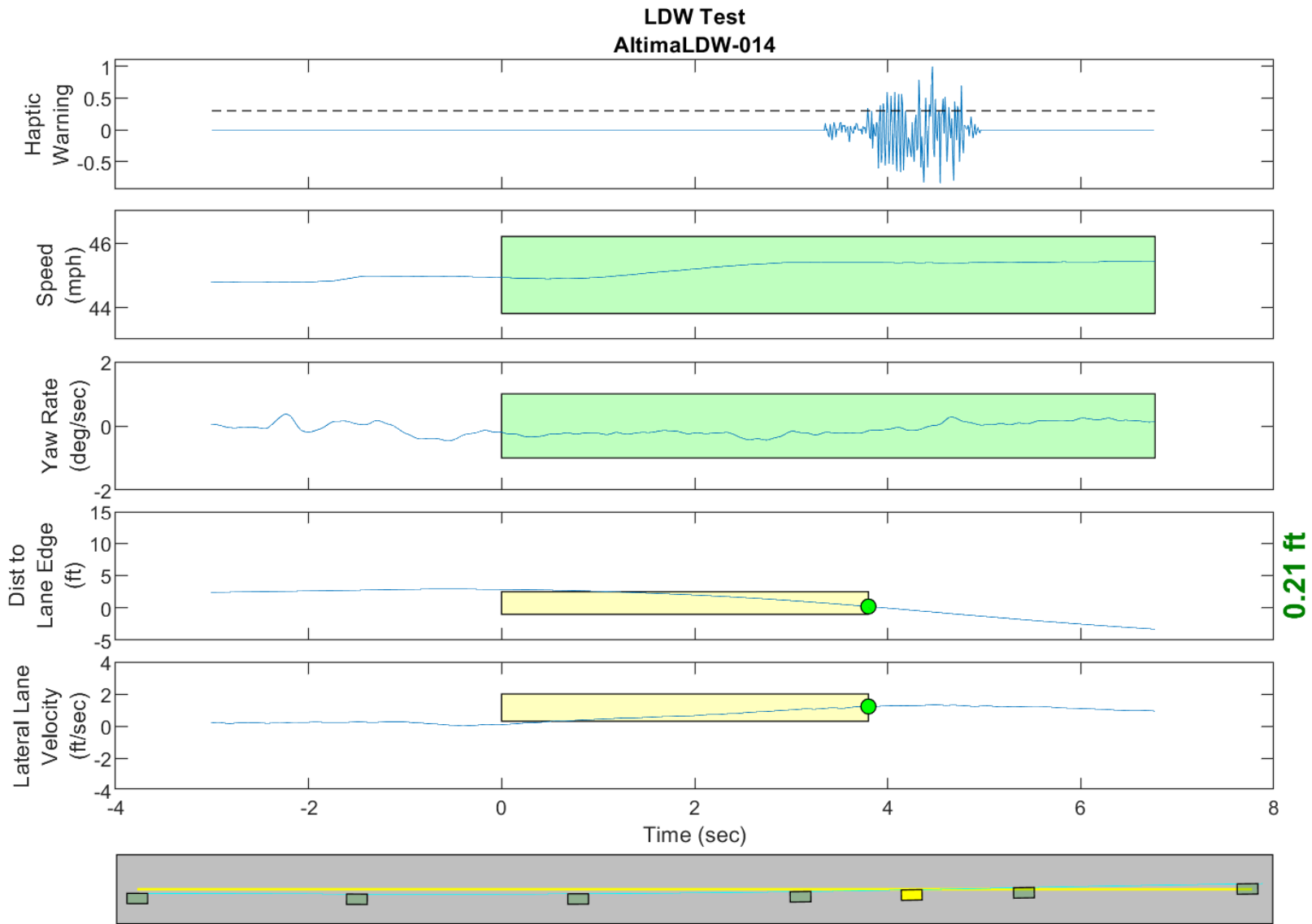

GPS Fix Type: RTK Fixed

Figure D28. Time History for Run 14, Botts Dots, Left Departure, Haptic Warning

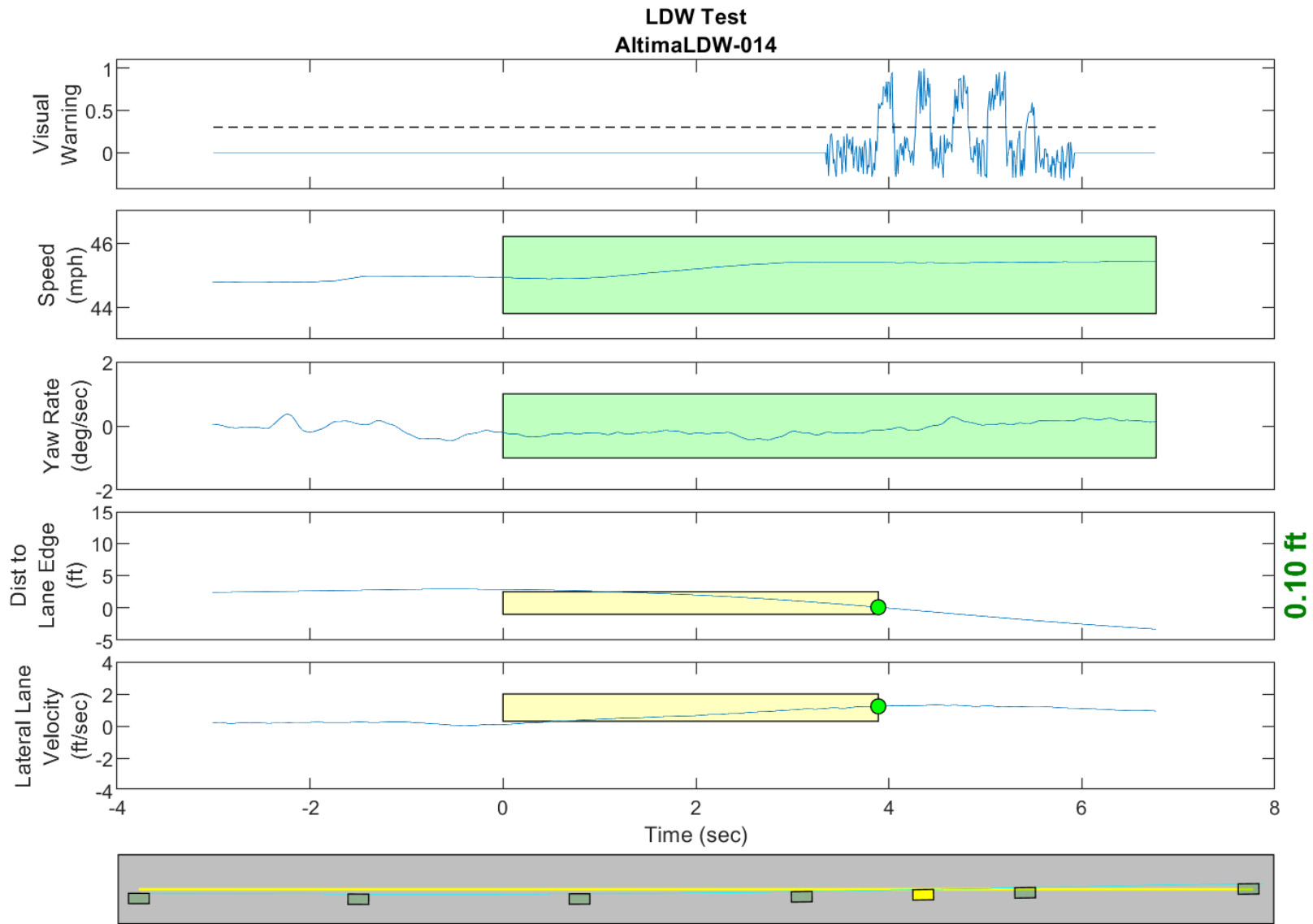

GPS Fix Type: RTK Fixed

Figure D29. Time History for Run 14, Botts Dots, Left Departure, Visual Warning

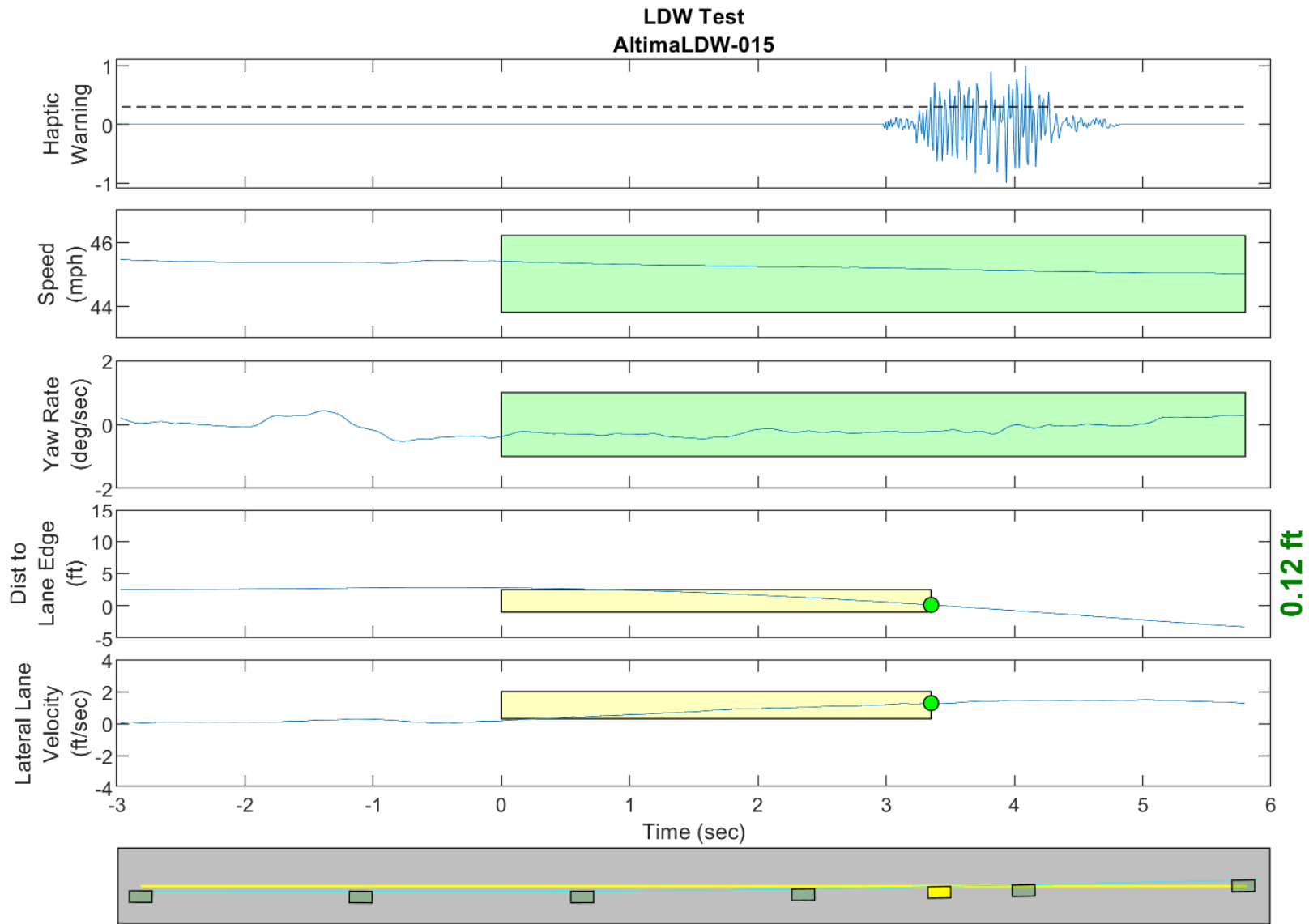

GPS Fix Type: RTK Fixed

Figure D30. Time History for Run 15, Botts Dots, Left Departure, Haptic Warning

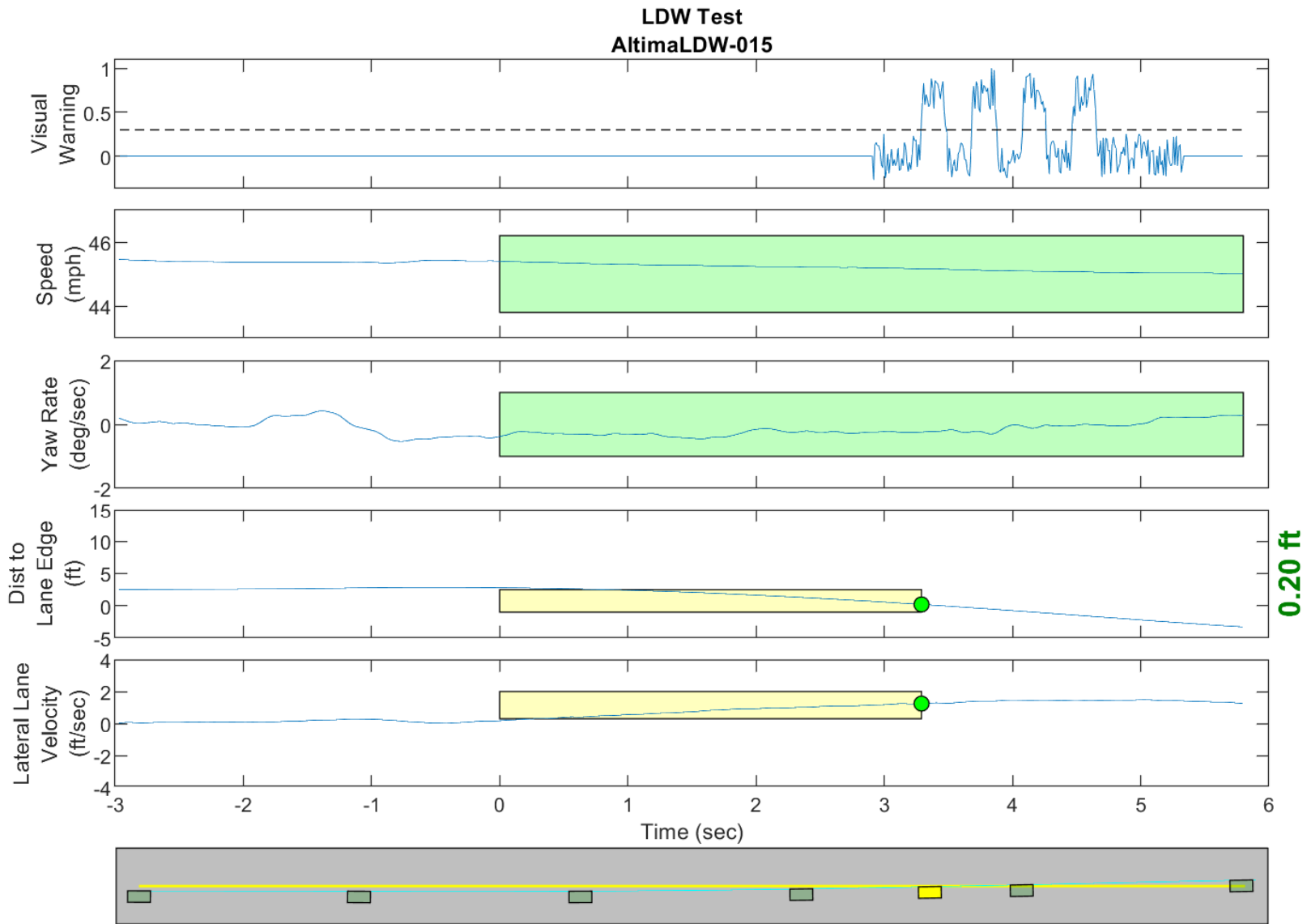

GPS Fix Type: RTK Fixed

Figure D31. Time History for Run 15, Botts Dots, Left Departure, Visual Warning

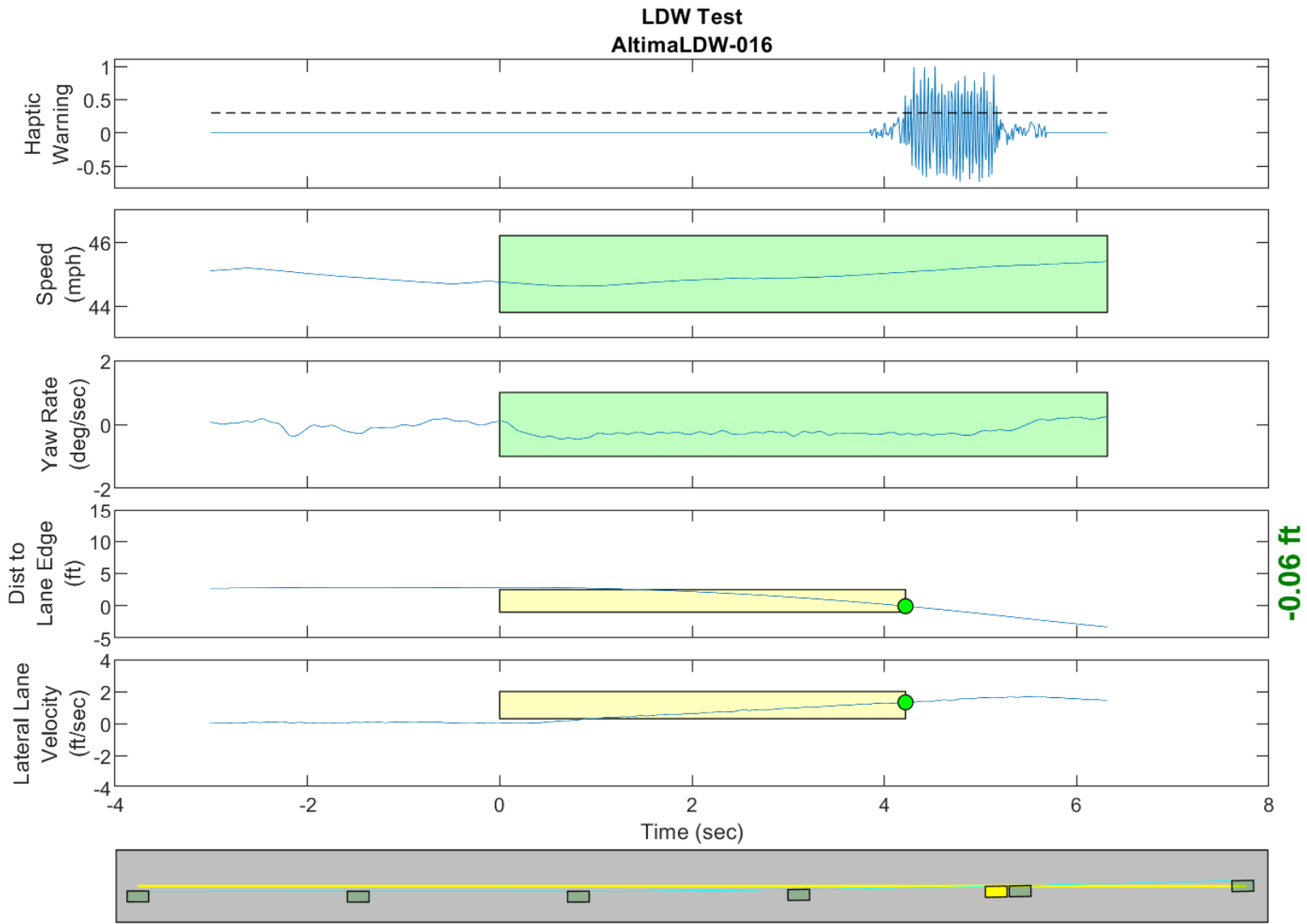

GPS Fix Type: RTK Fixed

Figure D32. Time History for Run 16, Solid Line, Left Departure, Haptic Warning

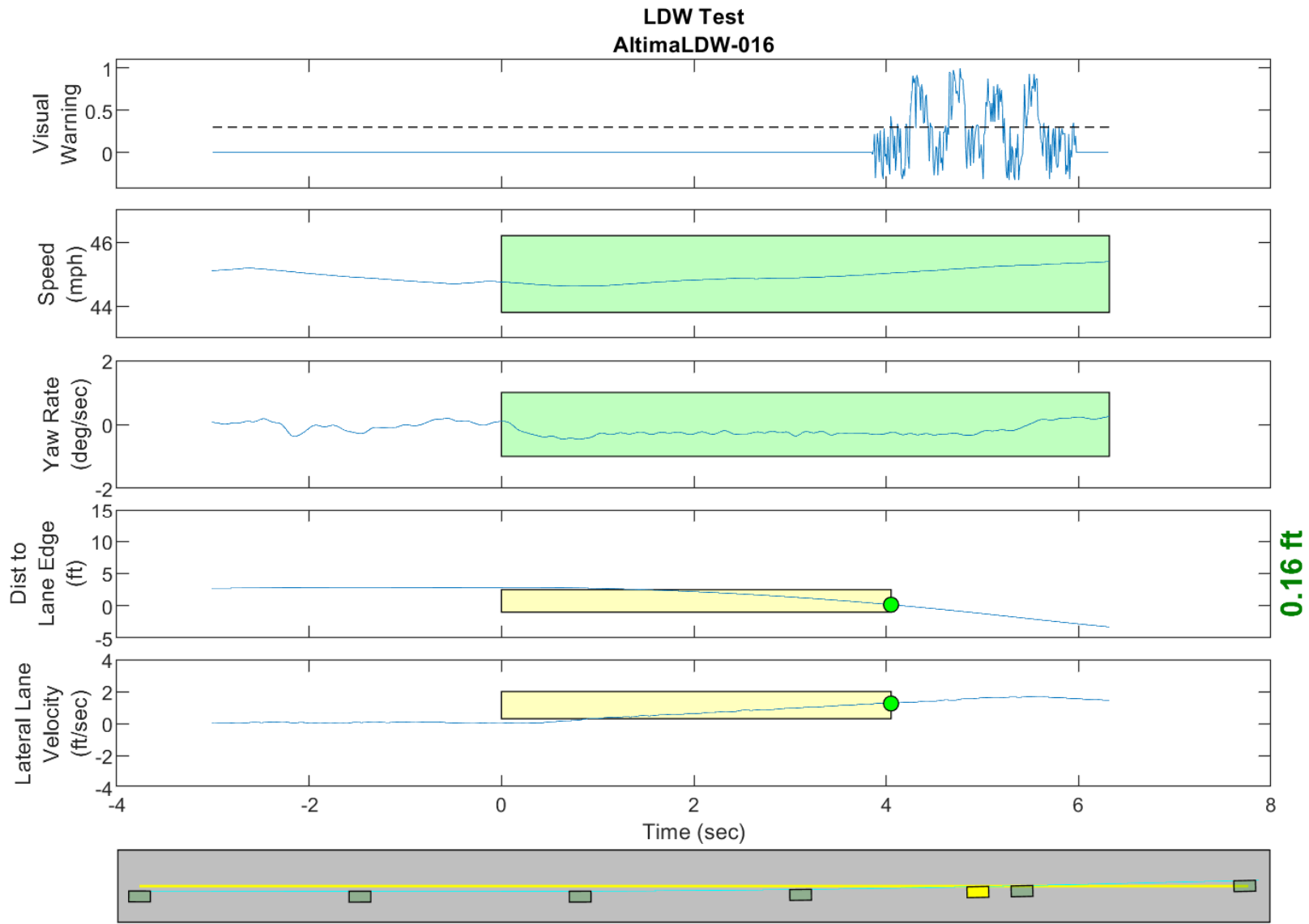

GPS Fix Type: RTK Fixed

Figure D33. Time History for Run 16, Solid Line, Left Departure, Visual Warning

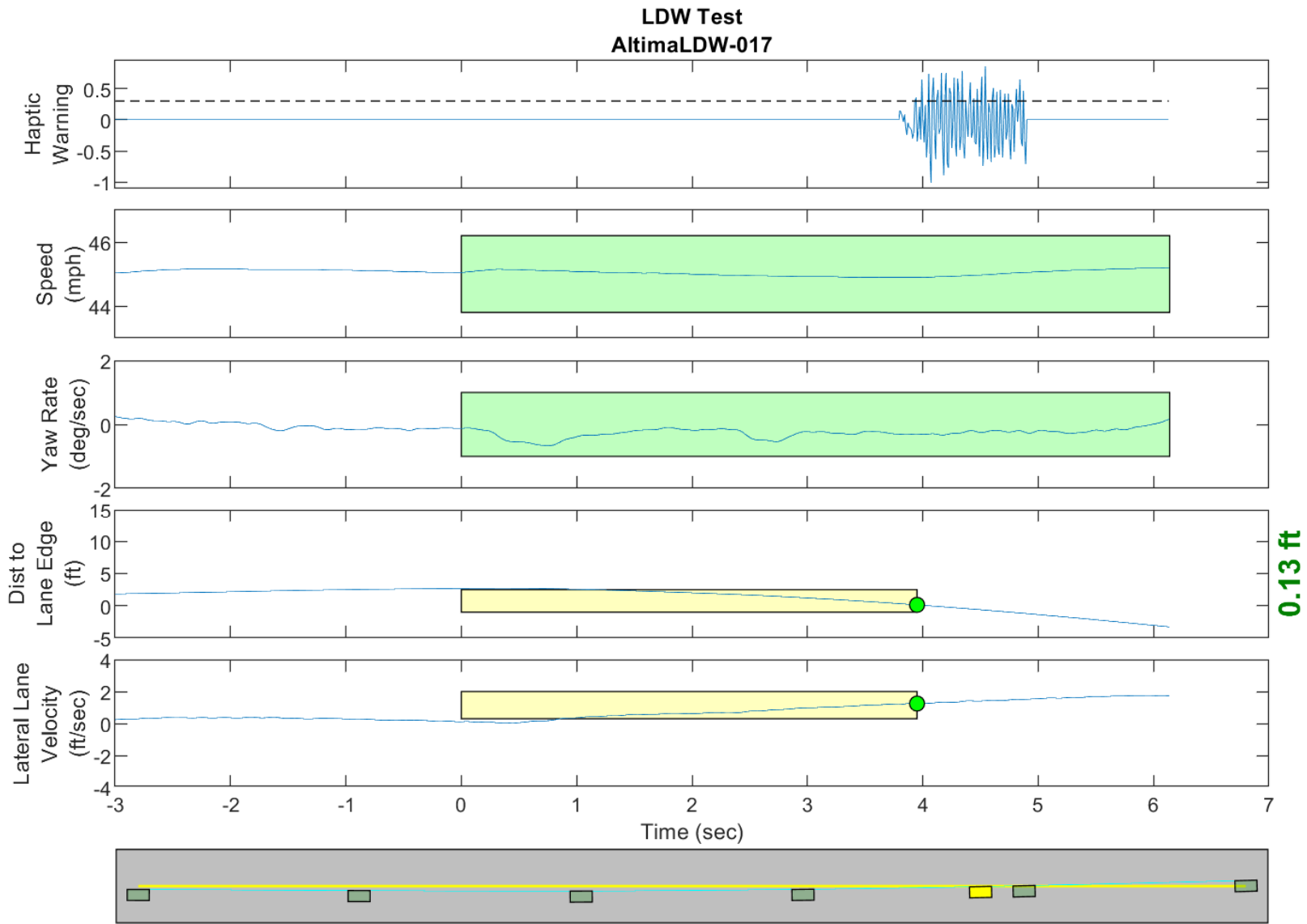

GPS Fix Type: RTK Fixed

Figure D34. Time History for Run 17, Solid Line, Left Departure, Haptic Warning

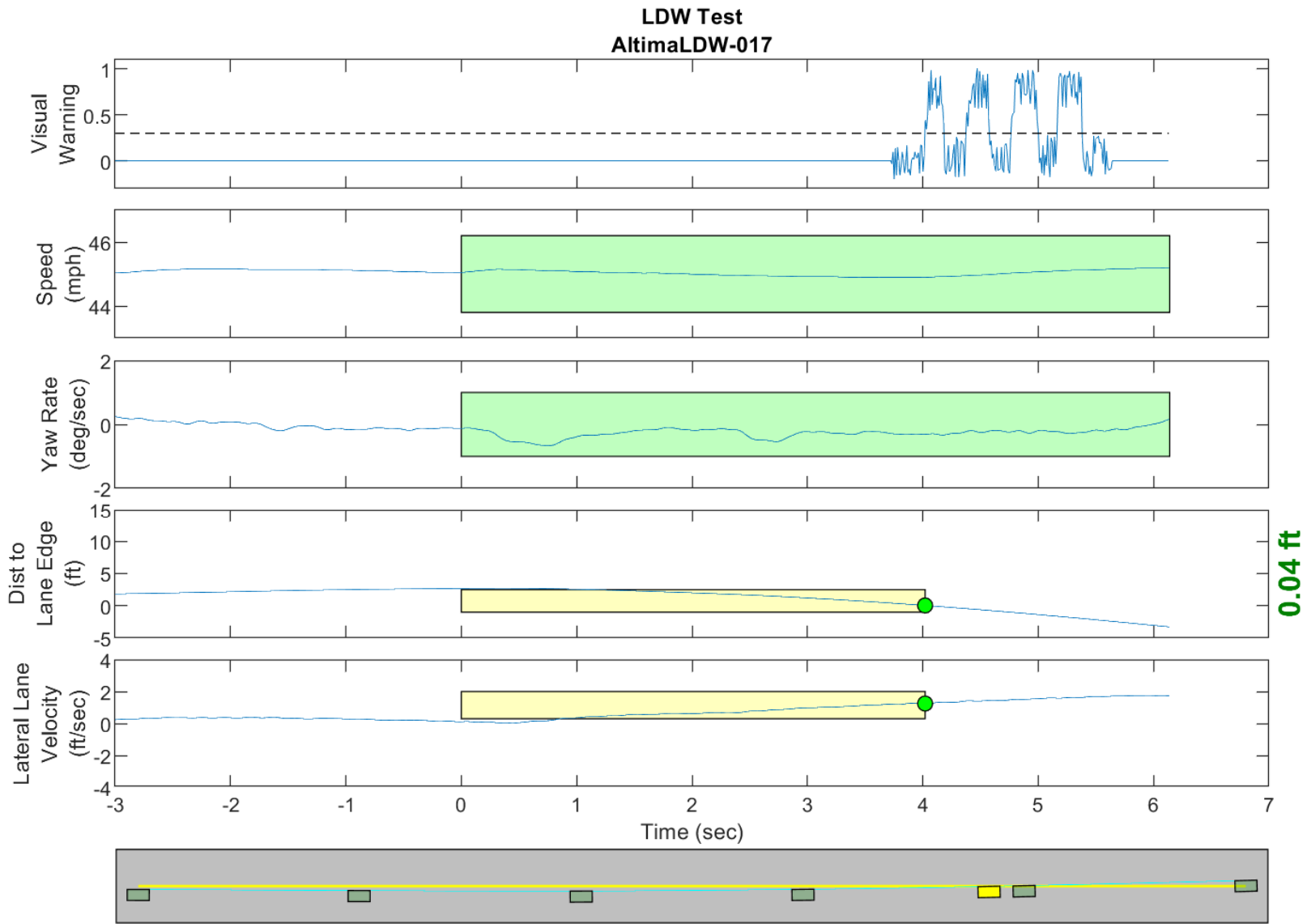

GPS Fix Type: RTK Fixed

Figure D35. Time History for Run 17, Solid Line, Left Departure, Visual Warning

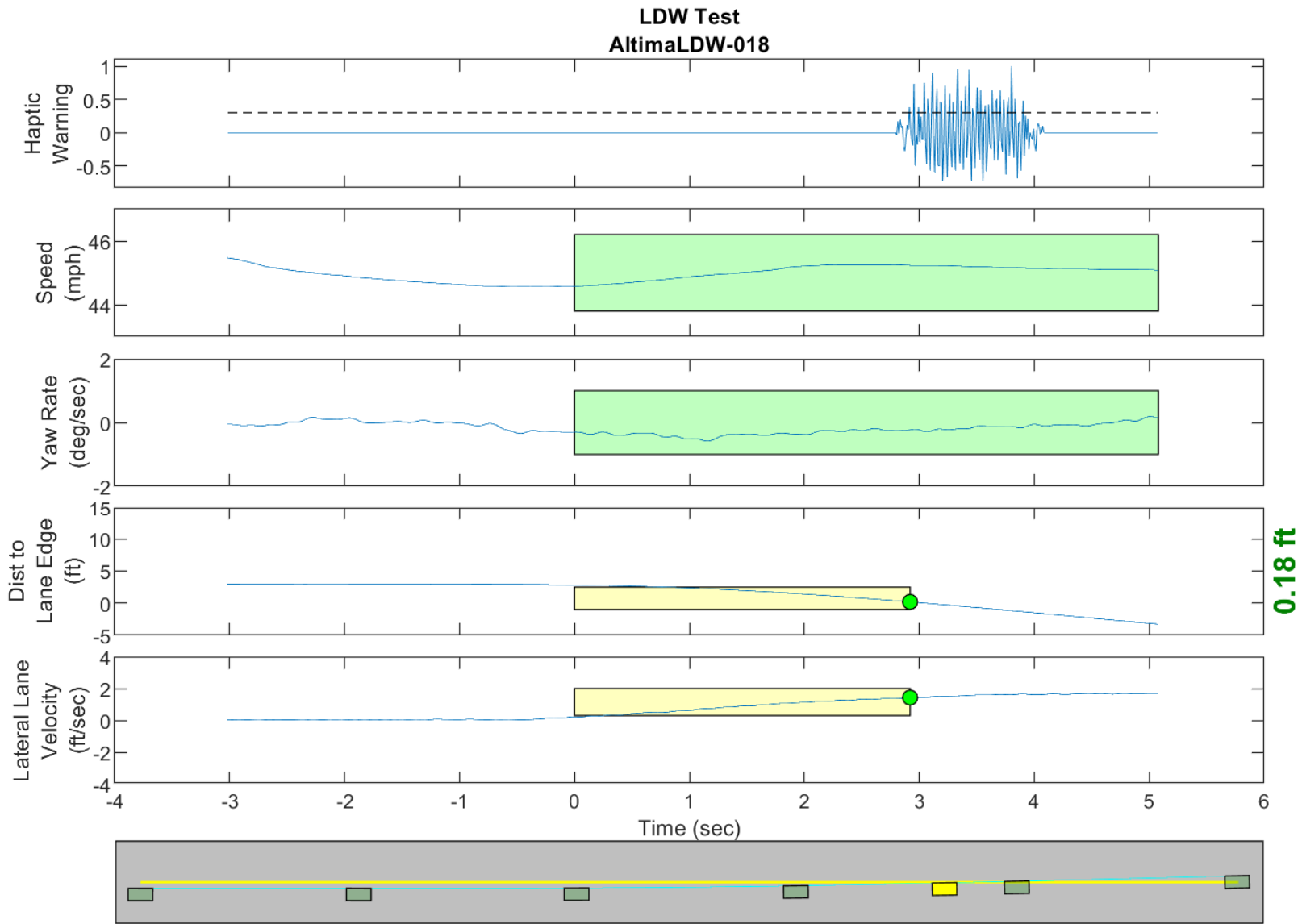

GPS Fix Type: RTK Fixed

Figure D36. Time History for Run 18, Solid Line, Left Departure, Haptic Warning

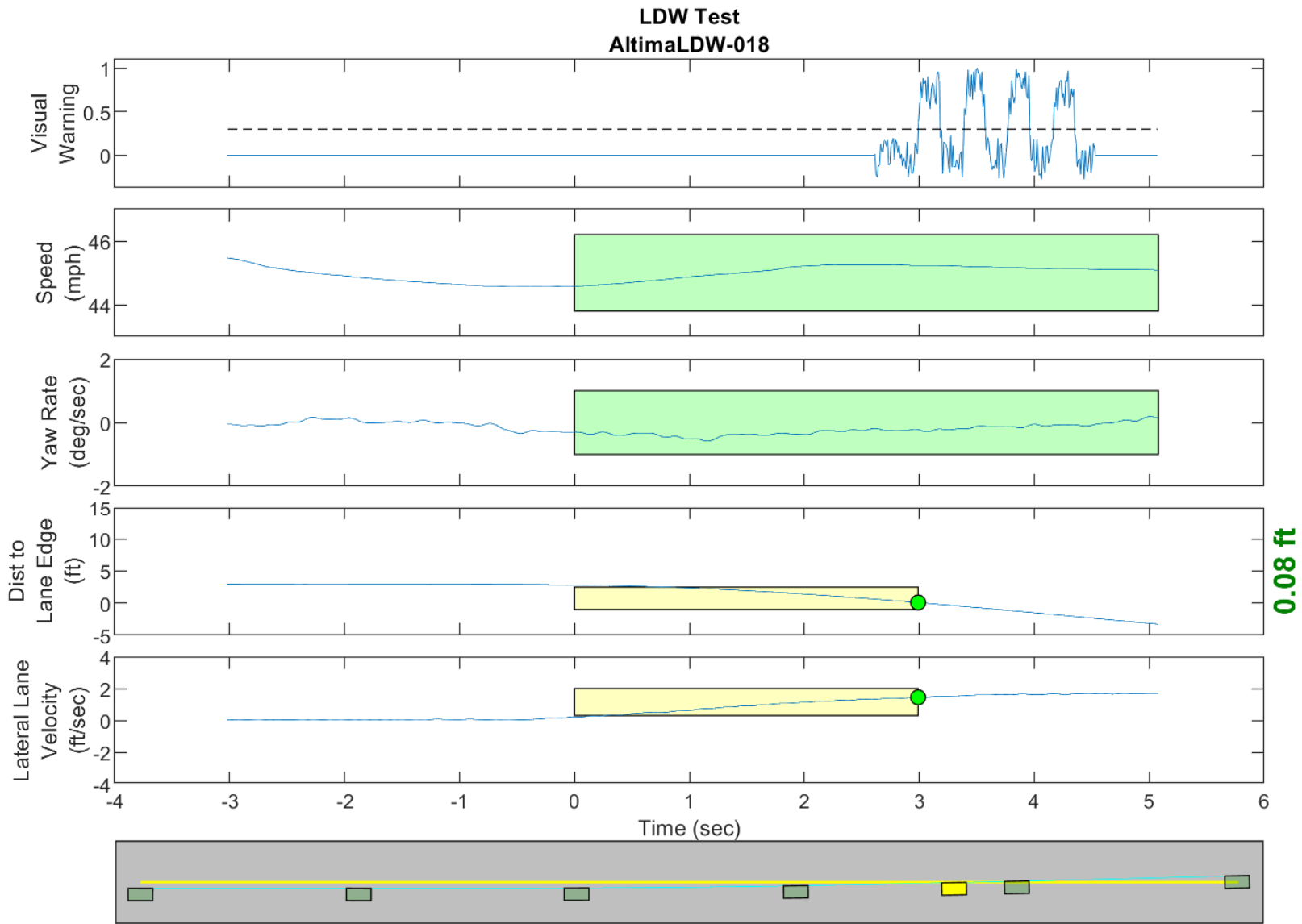

GPS Fix Type: RTK Fixed

Figure D37. Time History for Run 18, Solid Line, Left Departure, Visual Warning

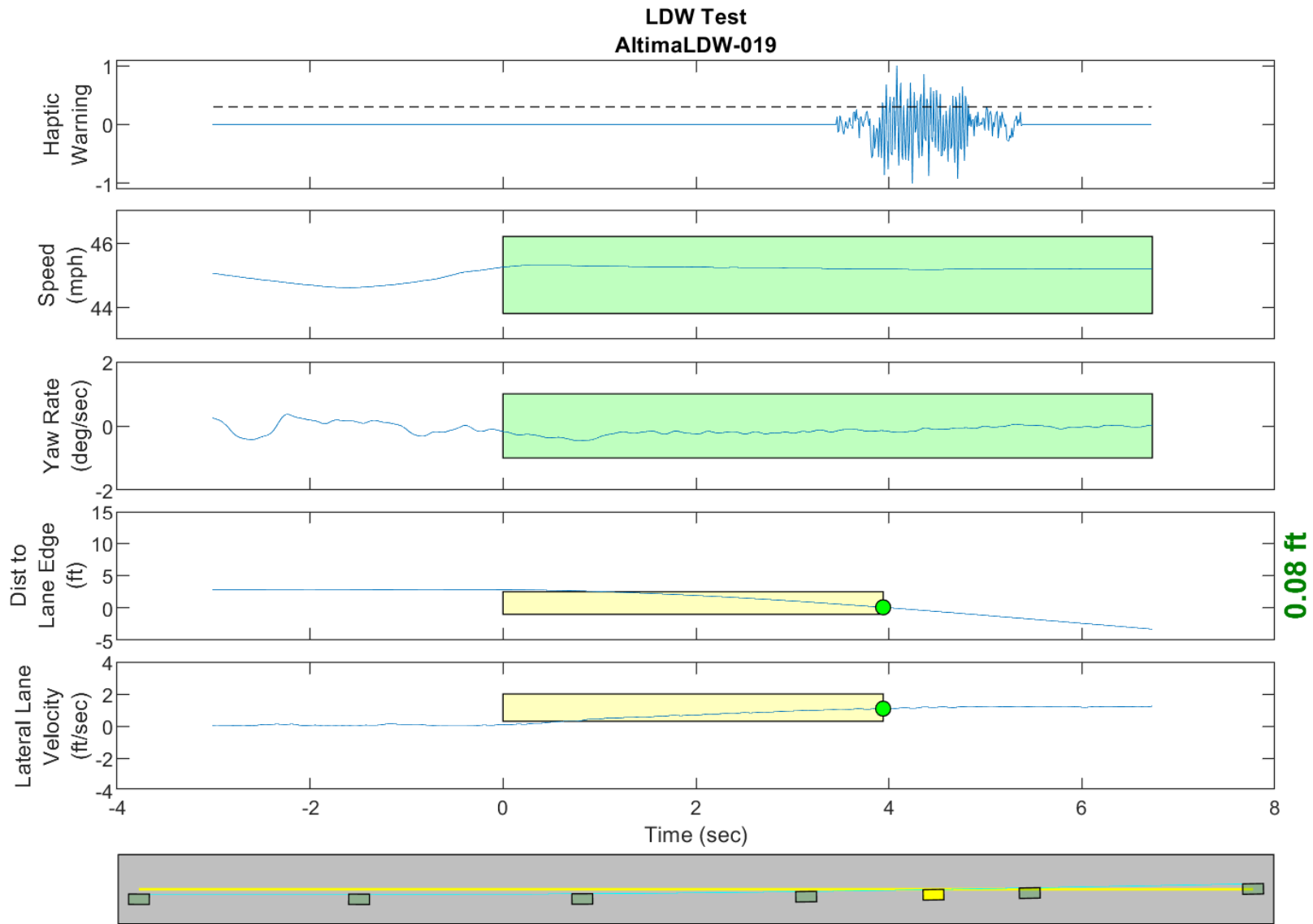

GPS Fix Type: RTK Fixed

Figure D38. Time History for Run 19, Solid Line, Left Departure, Haptic Warning

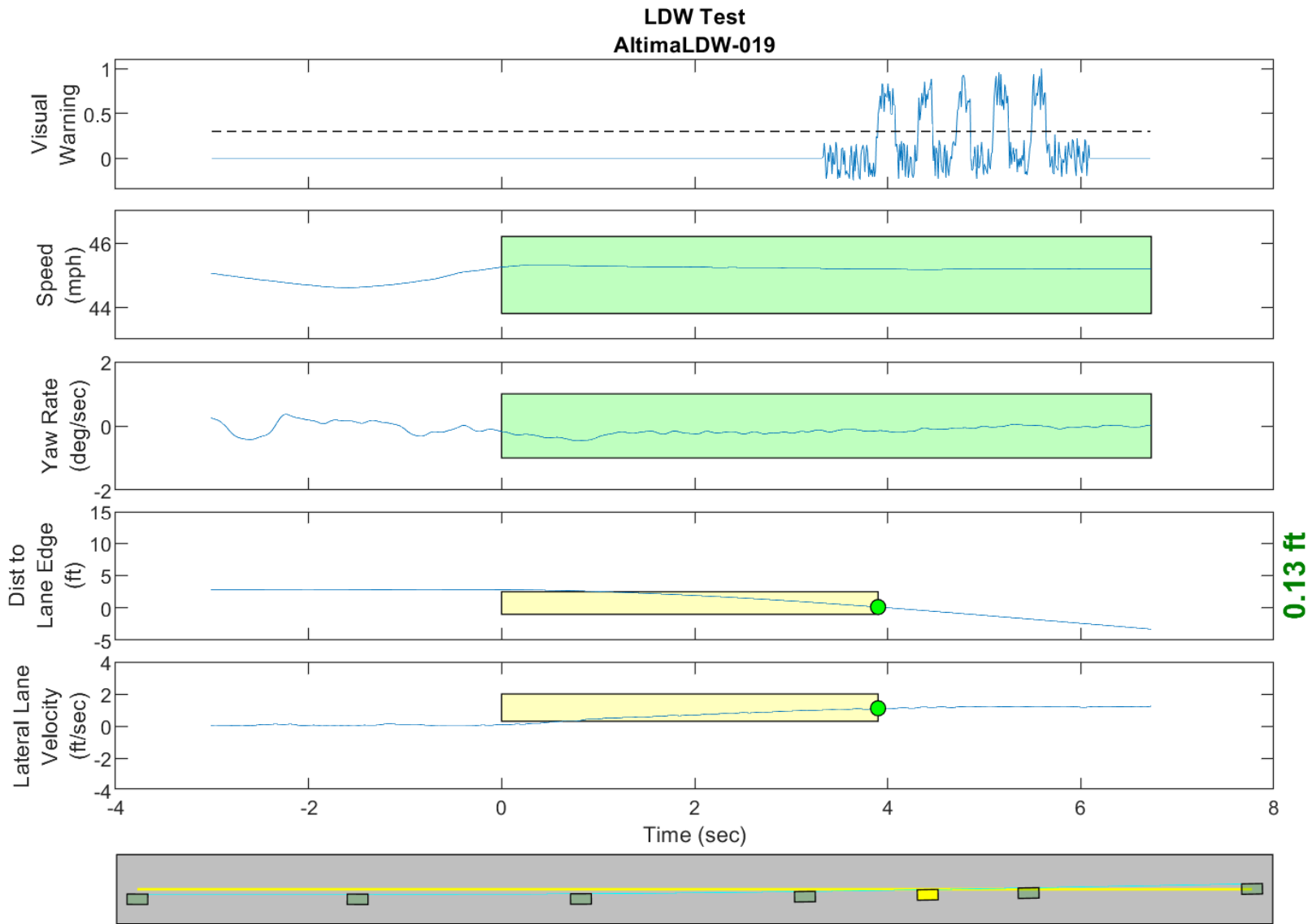

GPS Fix Type: RTK Fixed

Figure D39. Time History for Run 19, Solid Line, Left Departure, Visual Warning

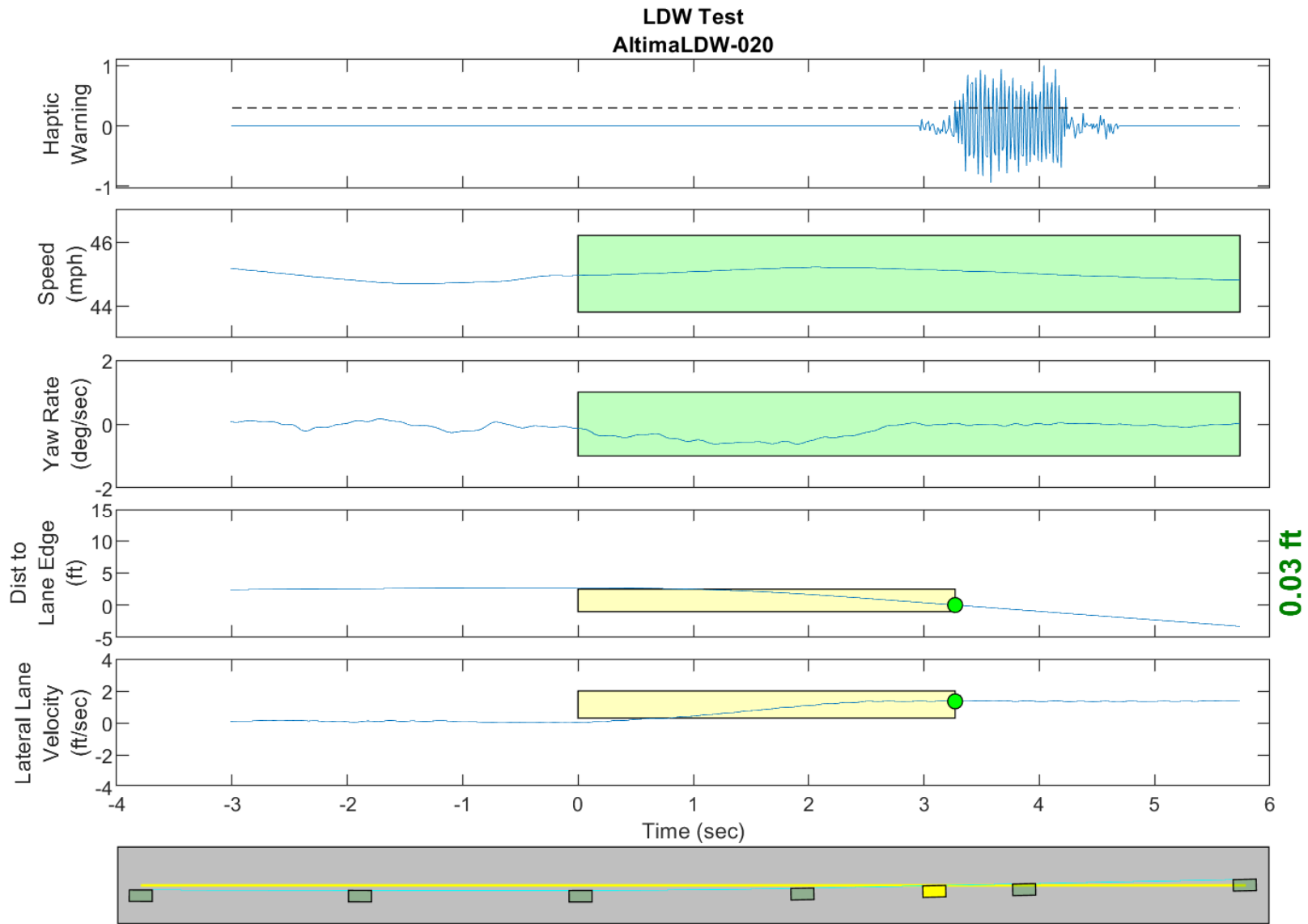

GPS Fix Type: RTK Fixed

Figure D40. Time History for Run 20, Solid Line, Left Departure, Haptic Warning

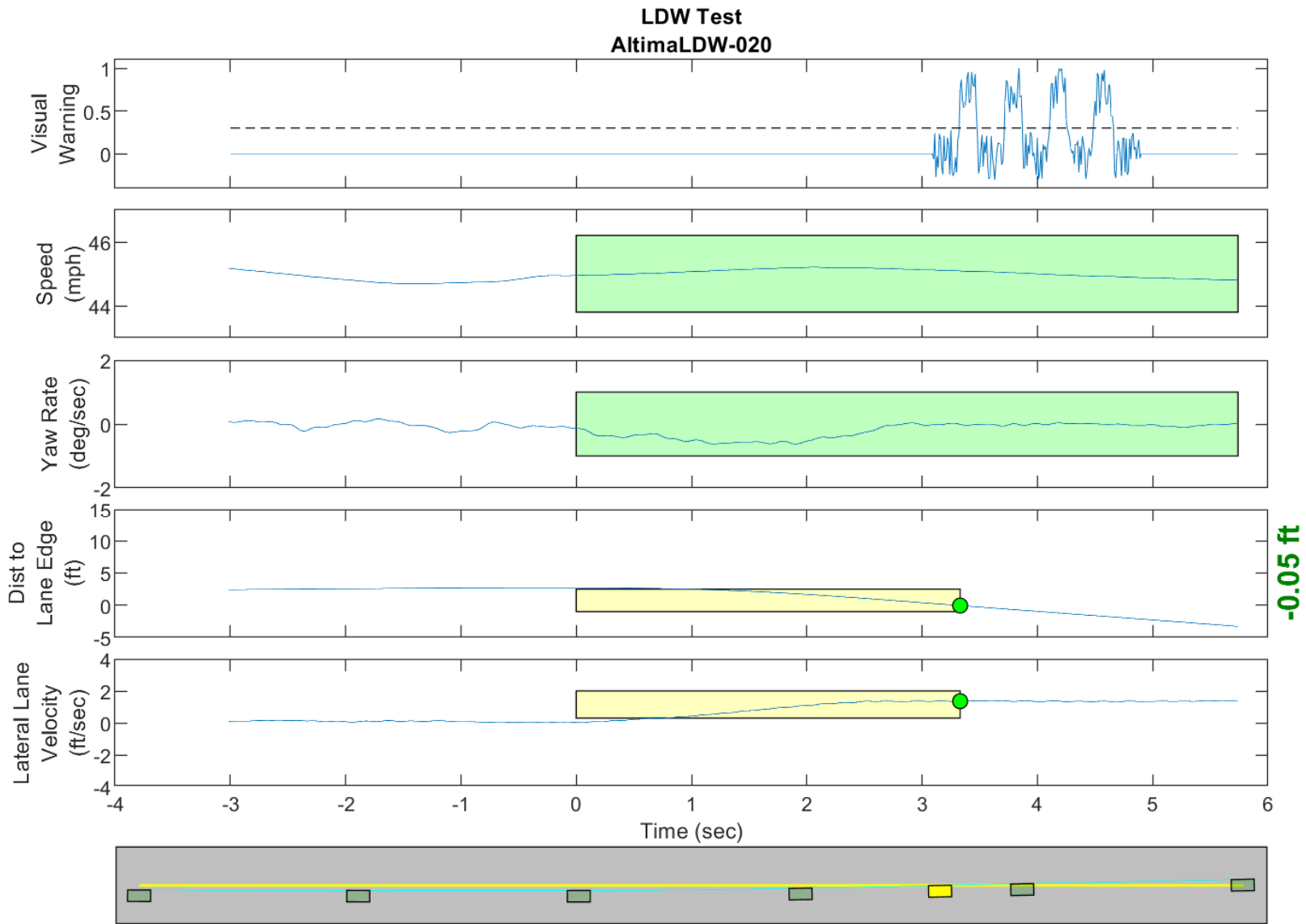

GPS Fix Type: RTK Fixed

Figure D41. Time History for Run 20, Solid Line, Left Departure, Visual Warning

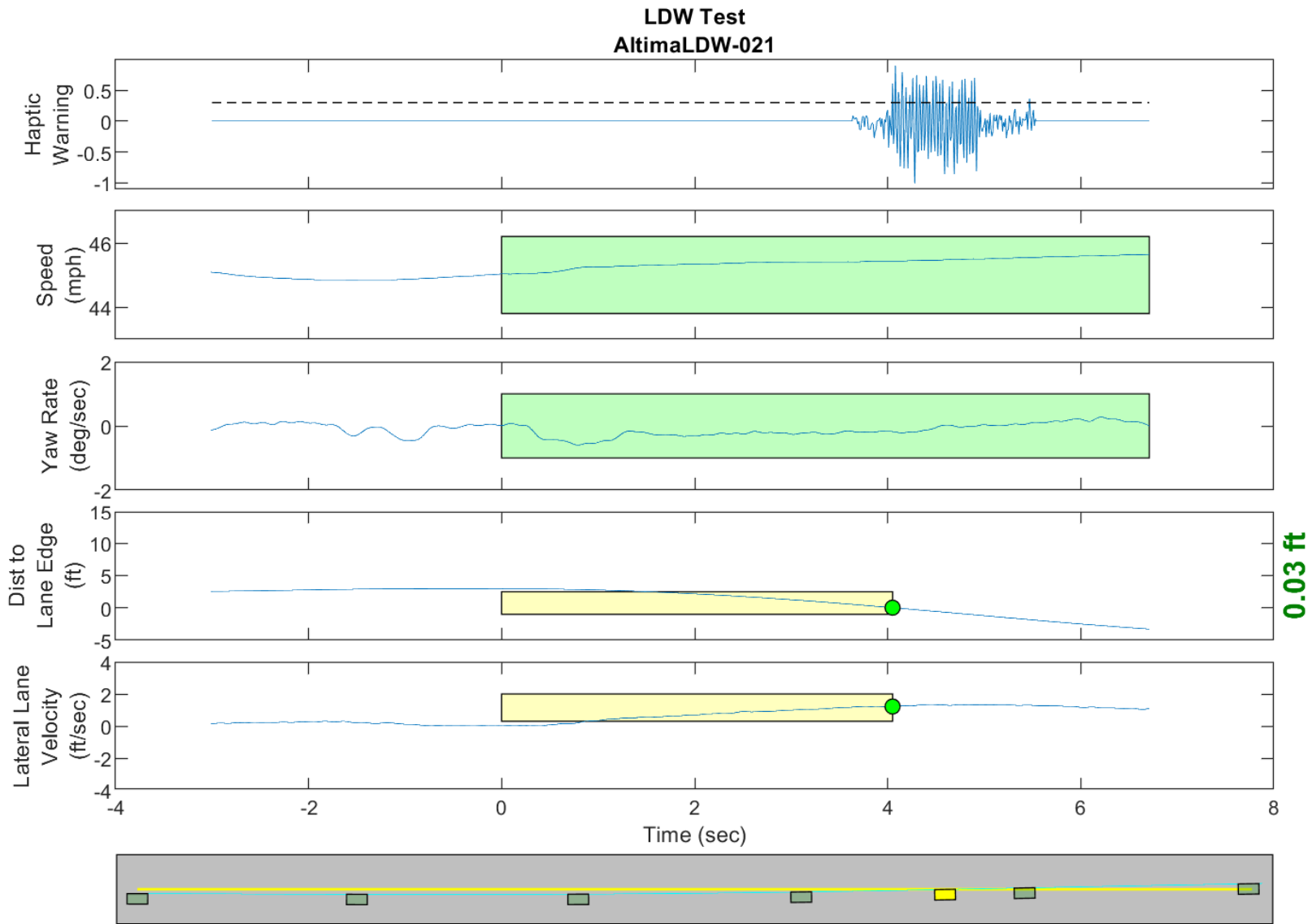

GPS Fix Type: RTK Fixed

Figure D42. Time History for Run 21, Solid Line, Left Departure, Haptic Warning

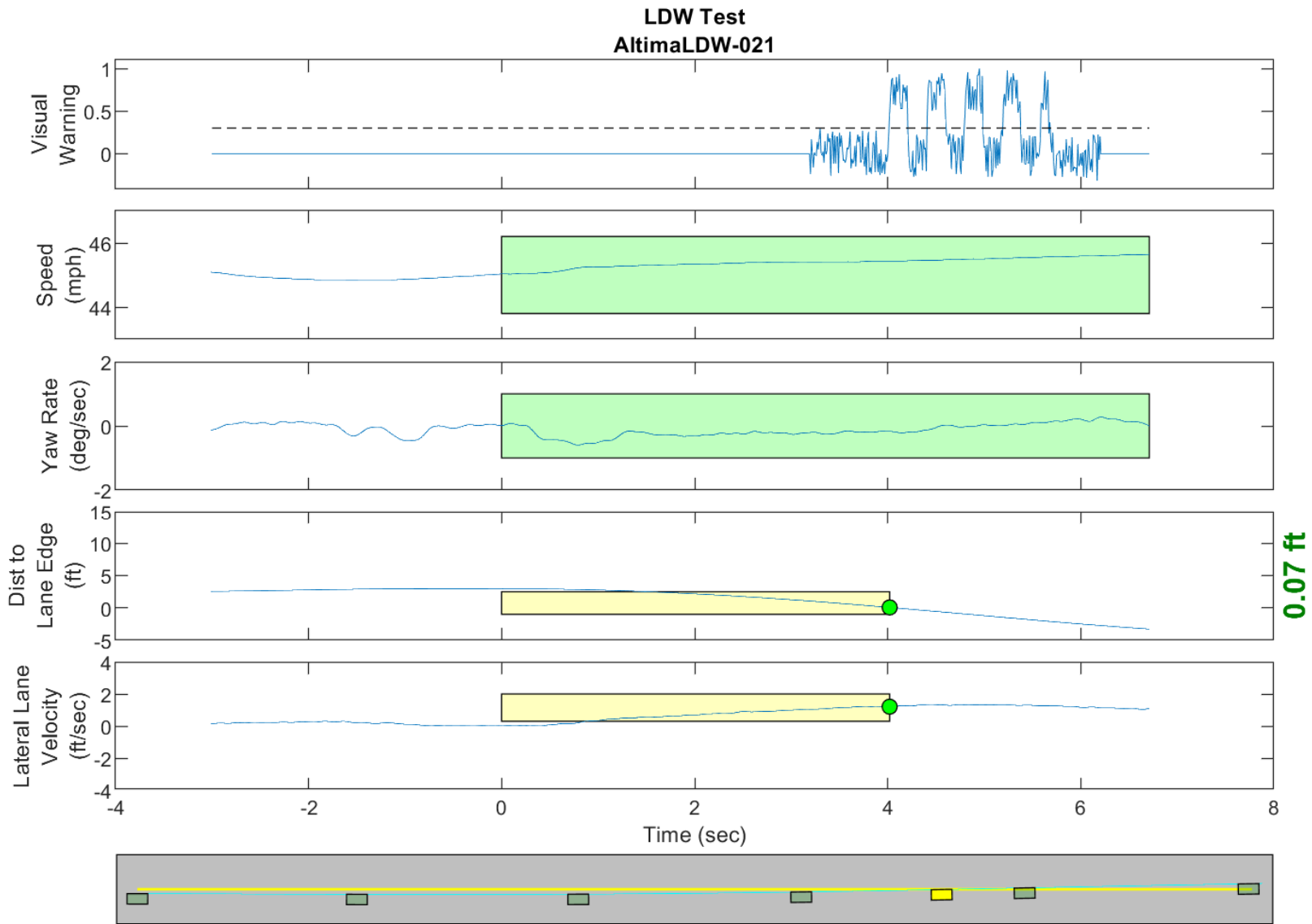

GPS Fix Type: RTK Fixed

Figure D43. Time History for Run 21, Solid Line, Left Departure, Visual Warning

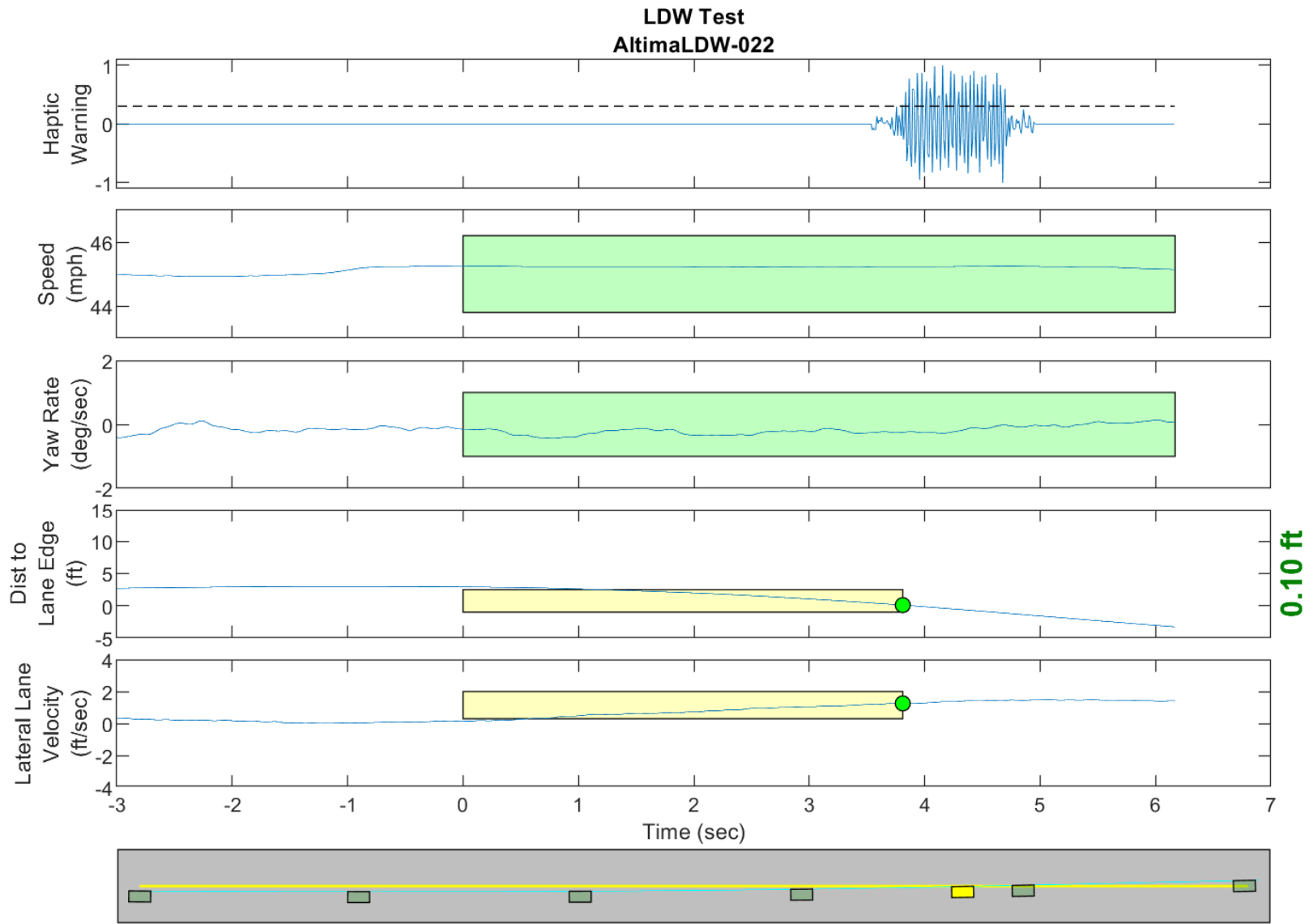

GPS Fix Type: RTK Fixed

Figure D44. Time History for Run 22, Solid Line, Left Departure, Haptic Warning

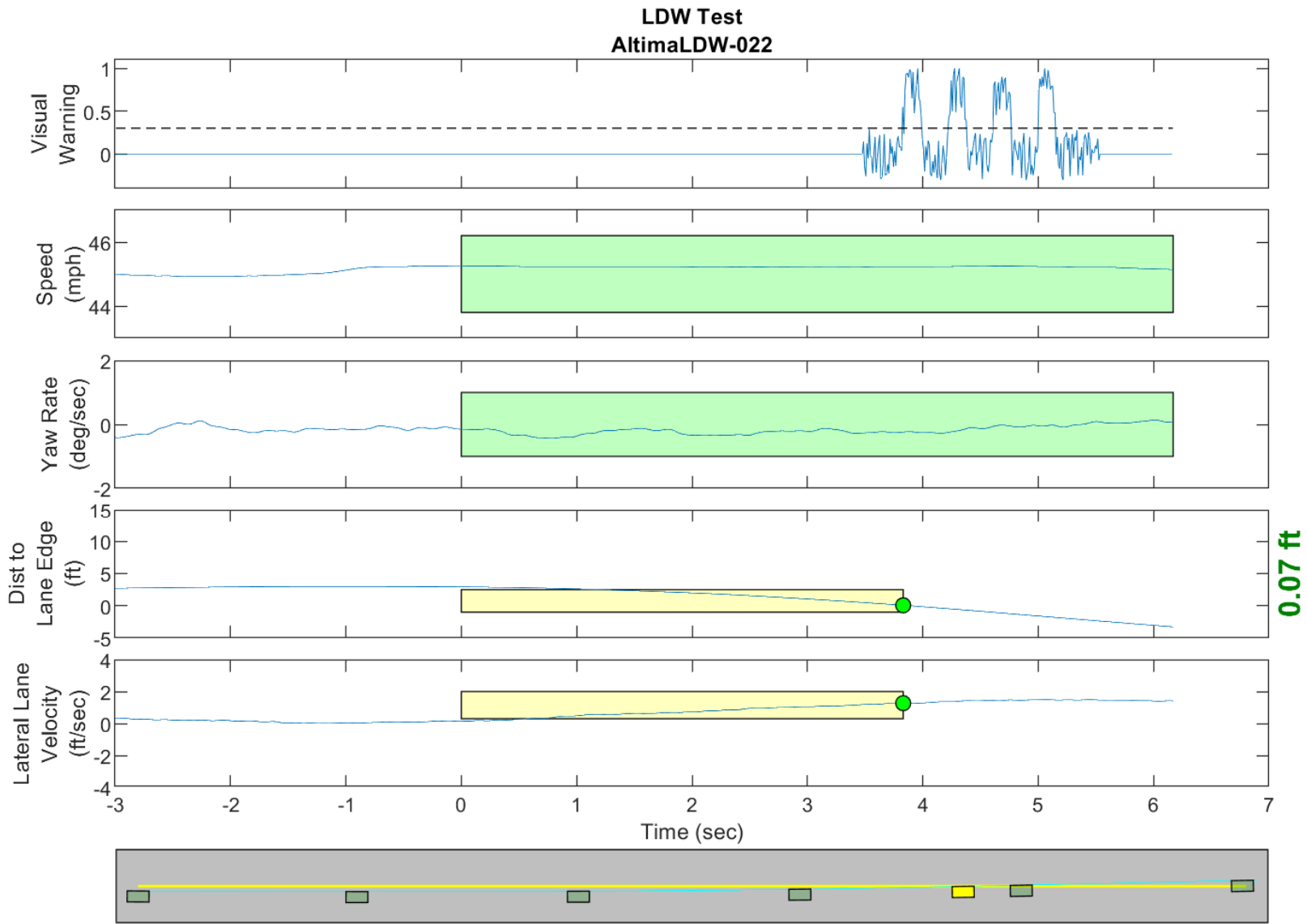

GPS Fix Type: RTK Fixed

Figure D45. Time History for Run 22, Solid Line, Left Departure, Visual Warning

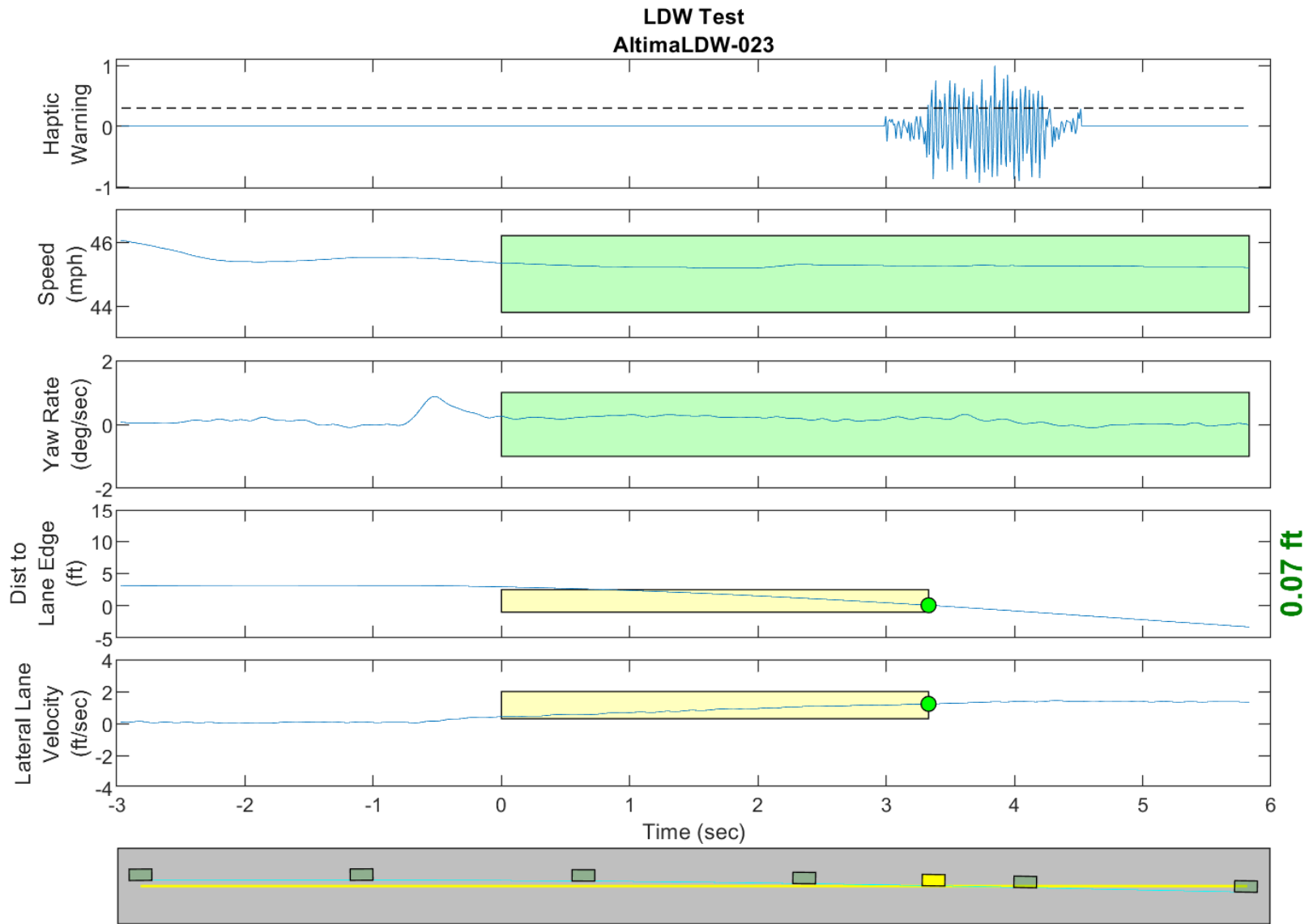

GPS Fix Type: RTK Fixed

Figure D46. Time History for Run 23, Solid Line, Right Departure, Haptic Warning

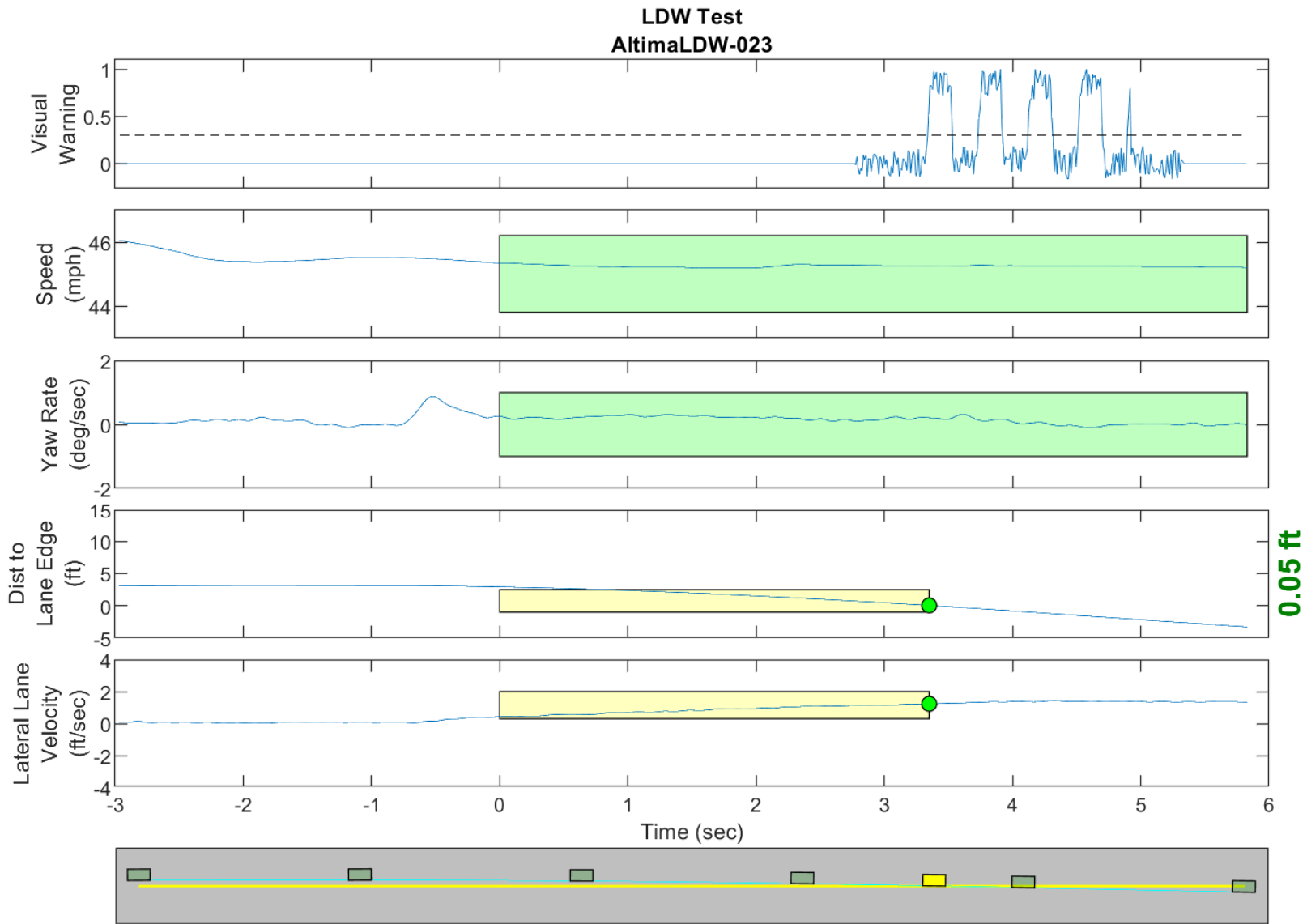

GPS Fix Type: RTK Fixed

Figure D47. Time History for Run 23, Solid Line, Right Departure, Visual Warning

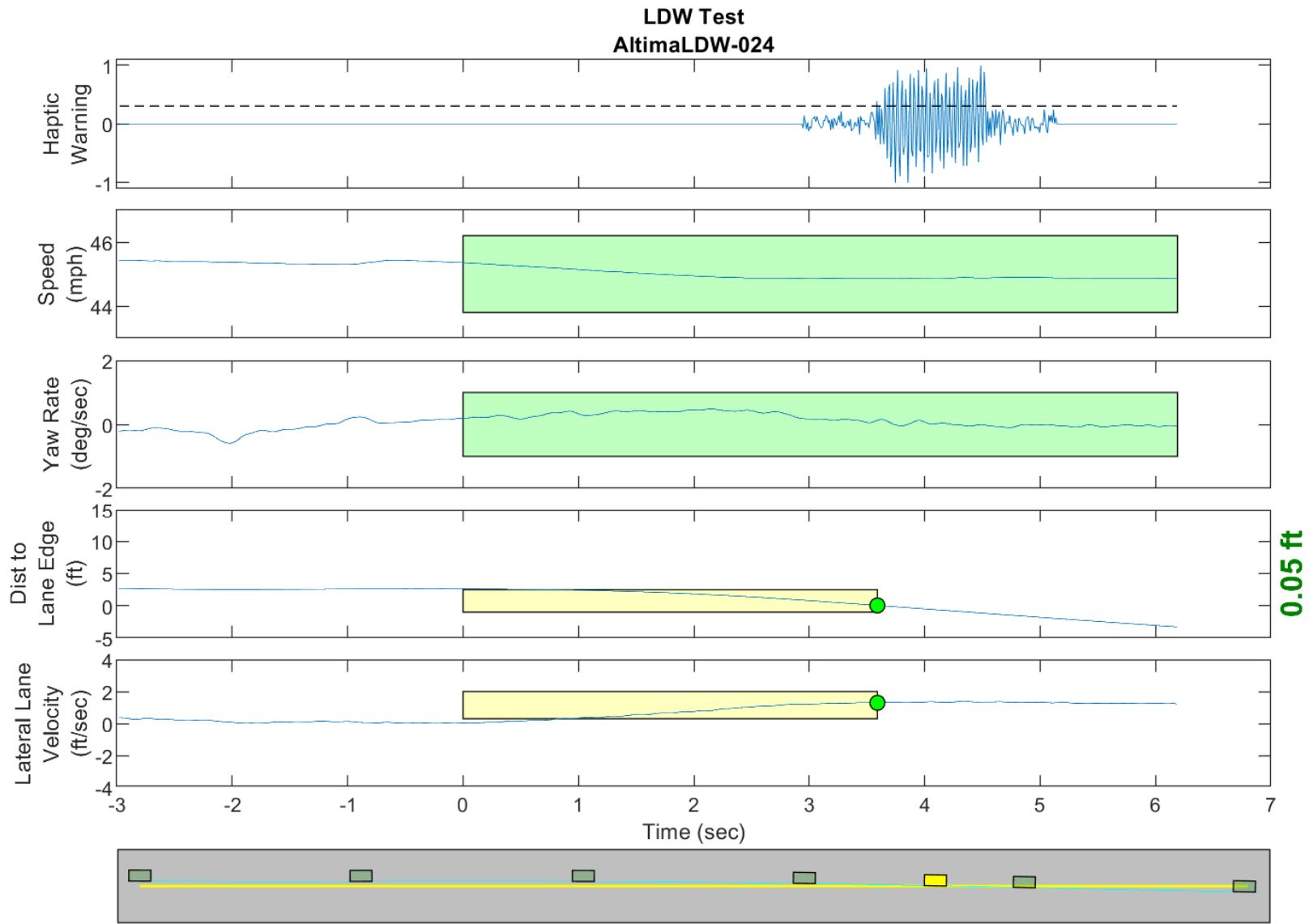
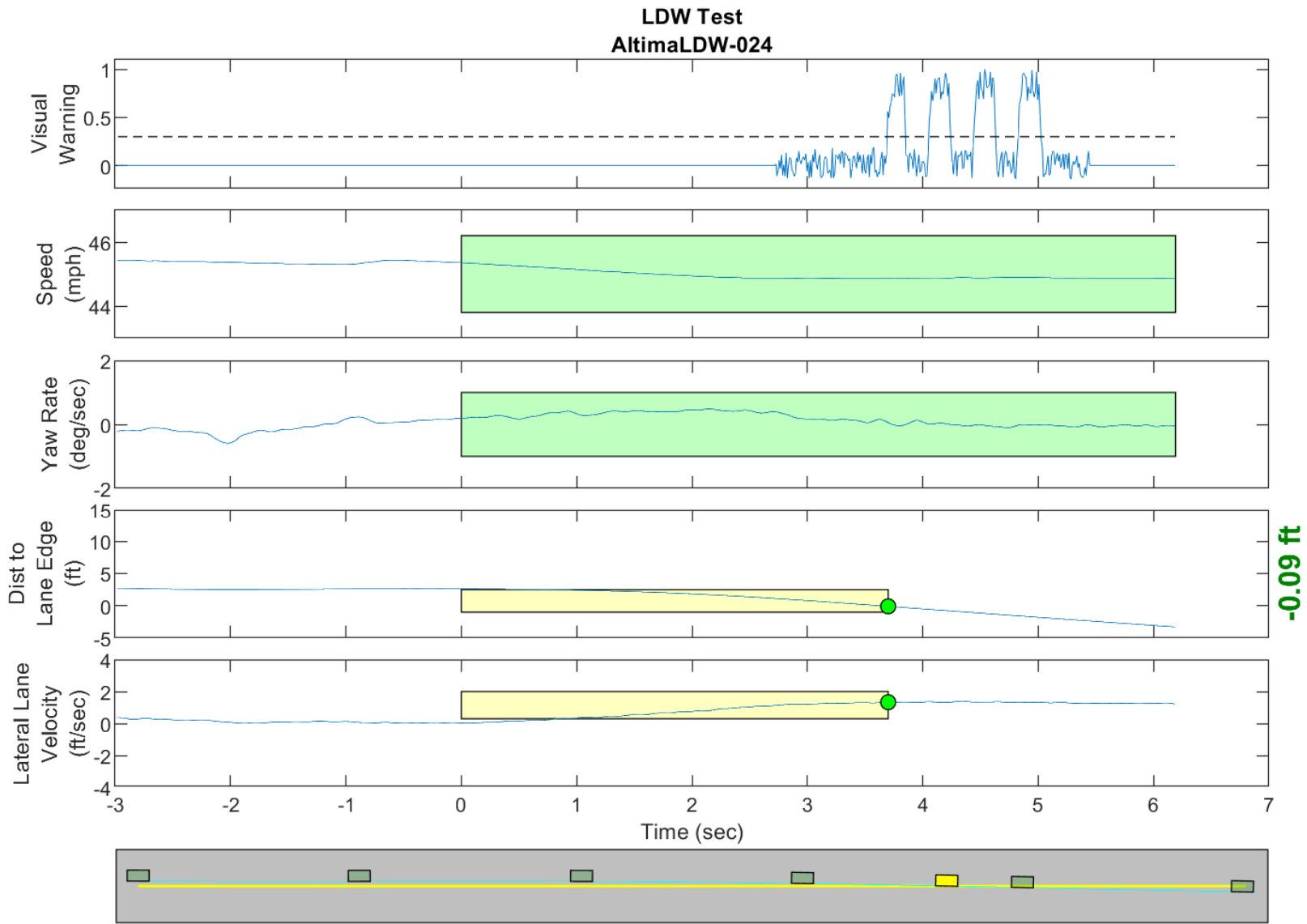
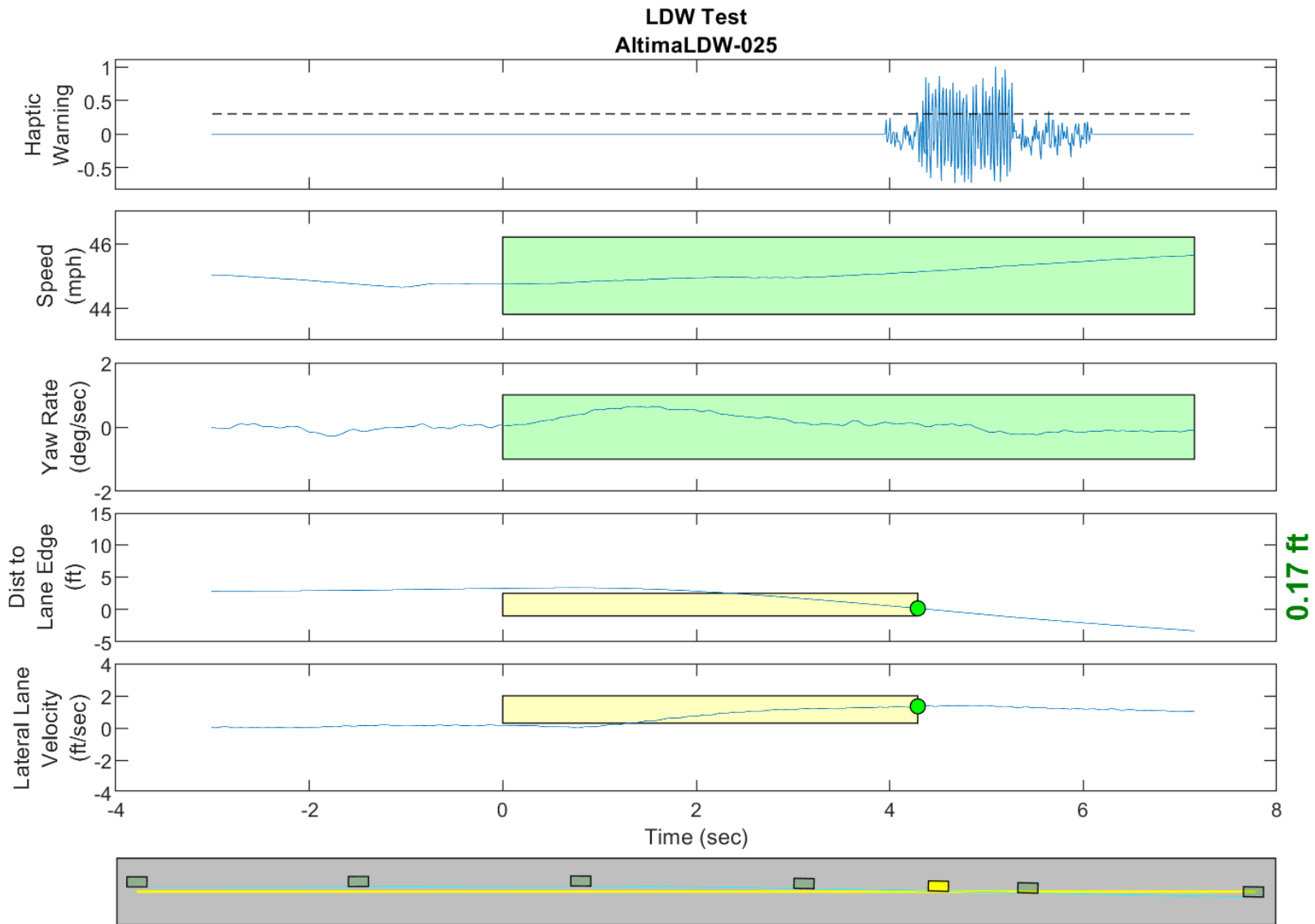

Figure D48. Time History for Run 24, Solid Line, Right Departure, Haptic Warning



GPS Fix Type: RTK Fixed

Figure D49. Time History for Run 24, Solid Line, Right Departure, Visual Warning



GPS Fix Type: RTK Fixed

Figure D50. Time History for Run 25, Solid Line, Right Departure, Haptic Warning

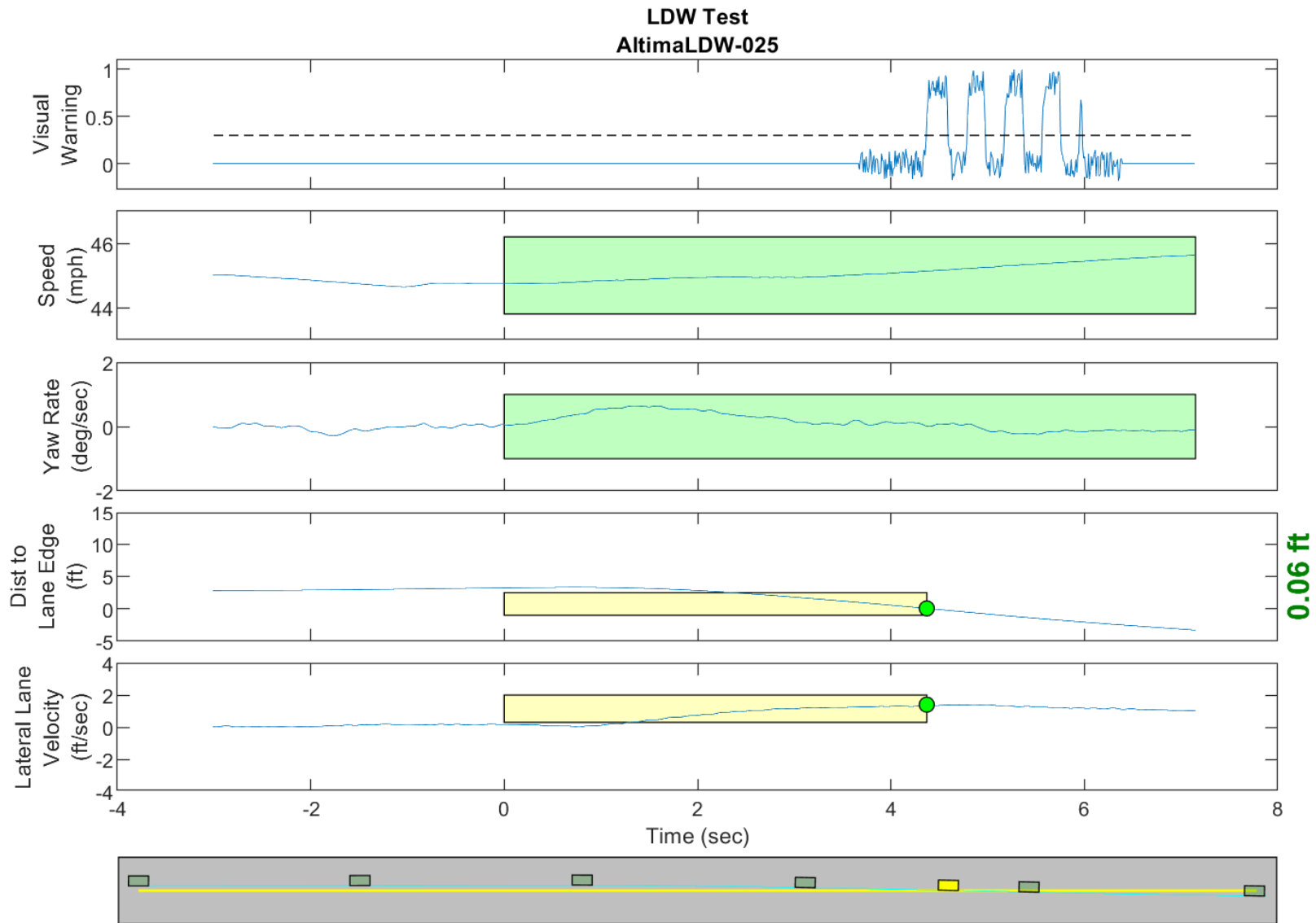

GPS Fix Type: RTK Fixed

Figure D51. Time History for Run 25, Solid Line, Right Departure, Visual Warning

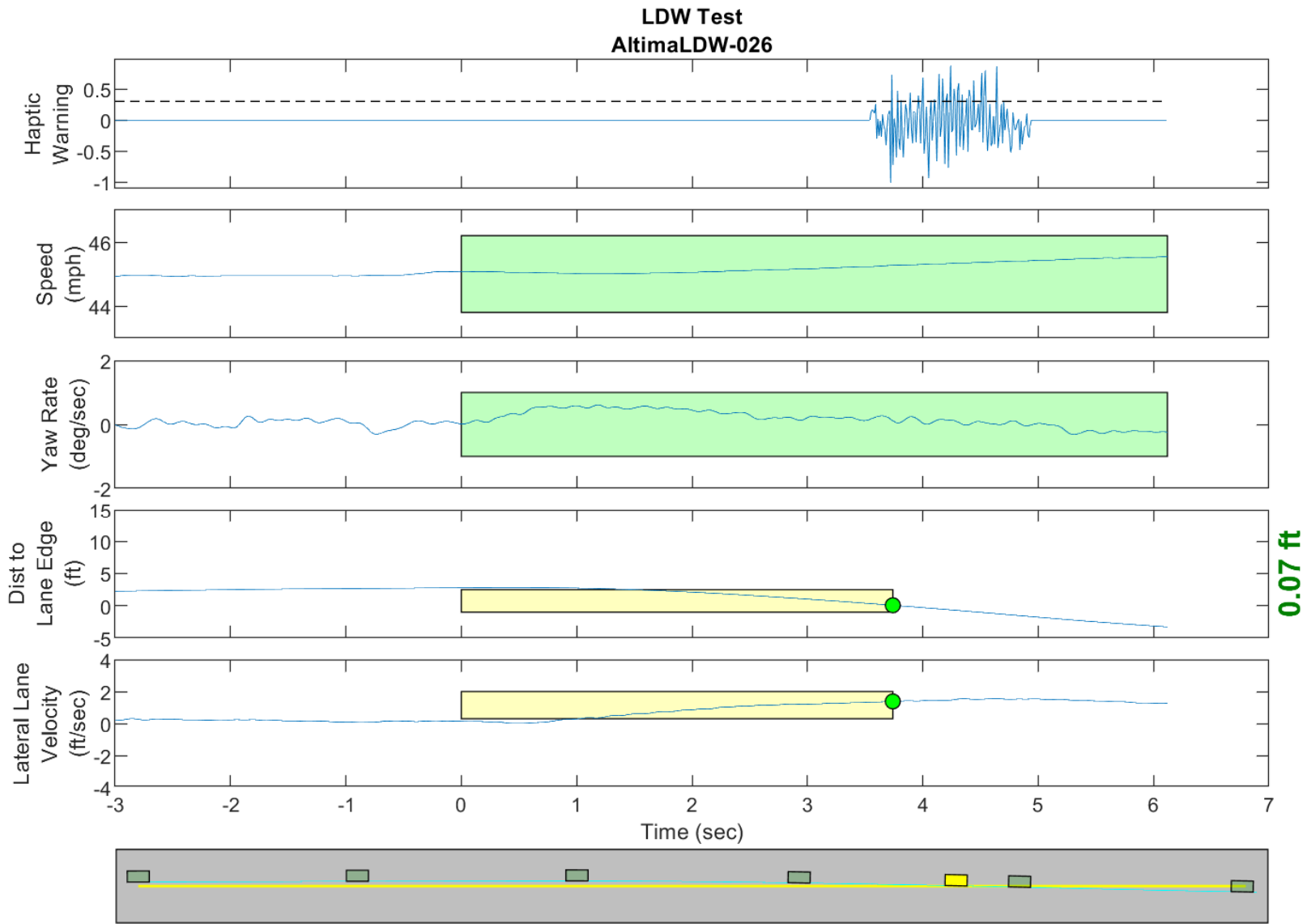

GPS Fix Type: RTK Fixed

Figure D52. Time History for Run 26, Solid Line, Right Departure, Haptic Warning

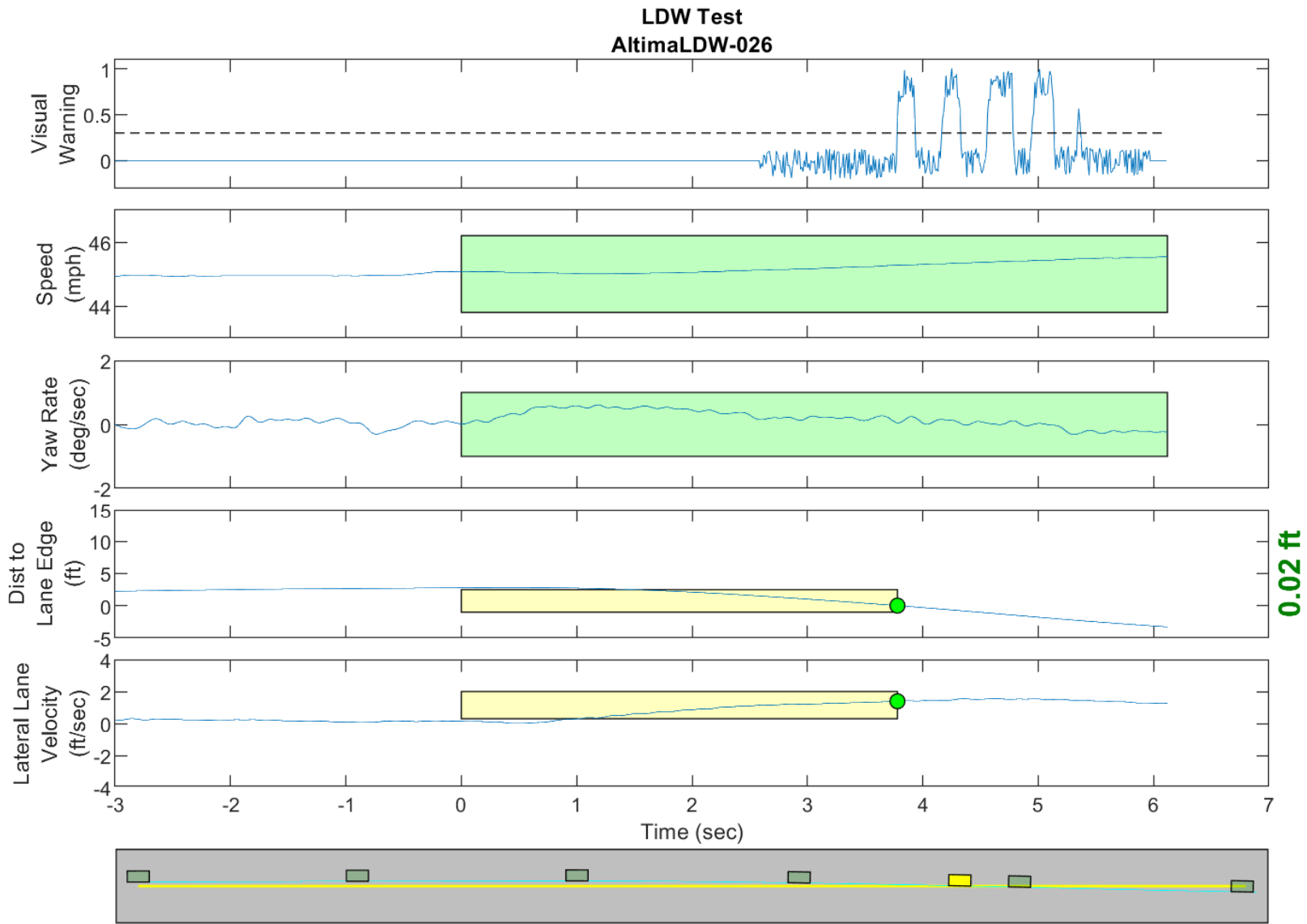

GPS Fix Type: RTK Fixed

Figure D53. Time History for Run 26, Solid Line, Right Departure, Visual Warning

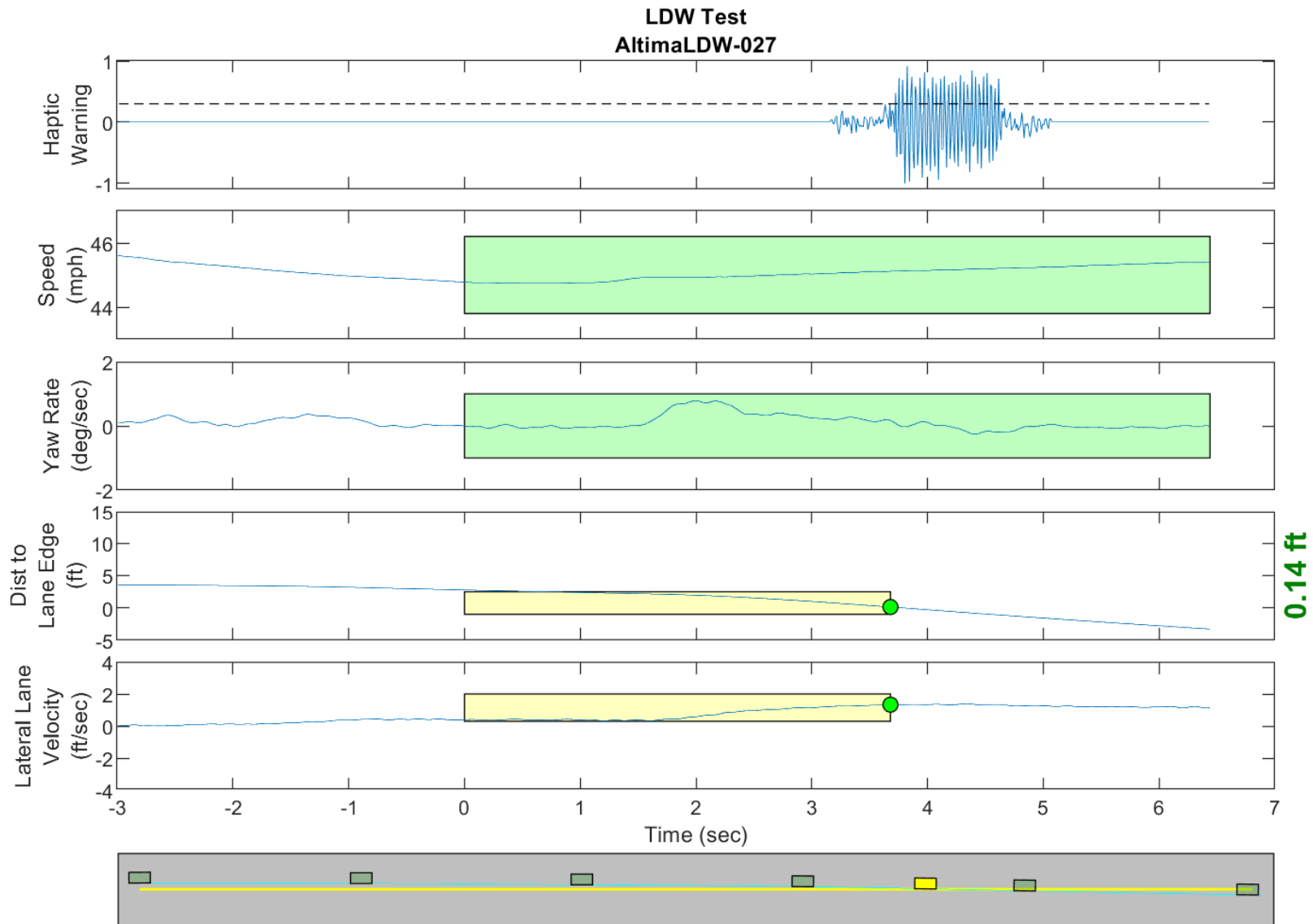

GPS Fix Type: RTK Fixed

Figure D54. Time History for Run 27, Solid Line, Right Departure, Haptic Warning

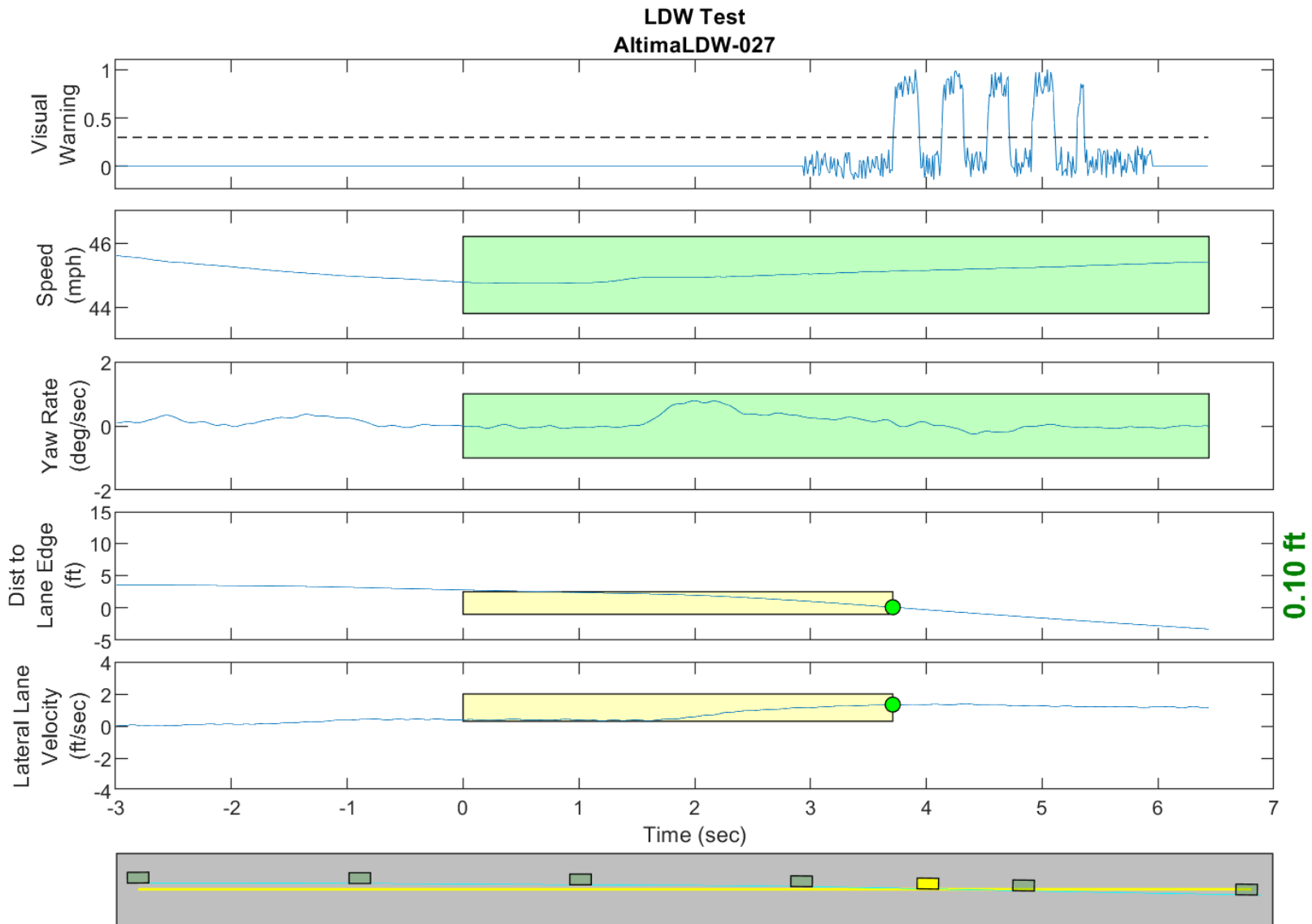

GPS Fix Type: RTK Fixed

Figure D55. Time History for Run 27, Solid Line, Right Departure, Visual Warning

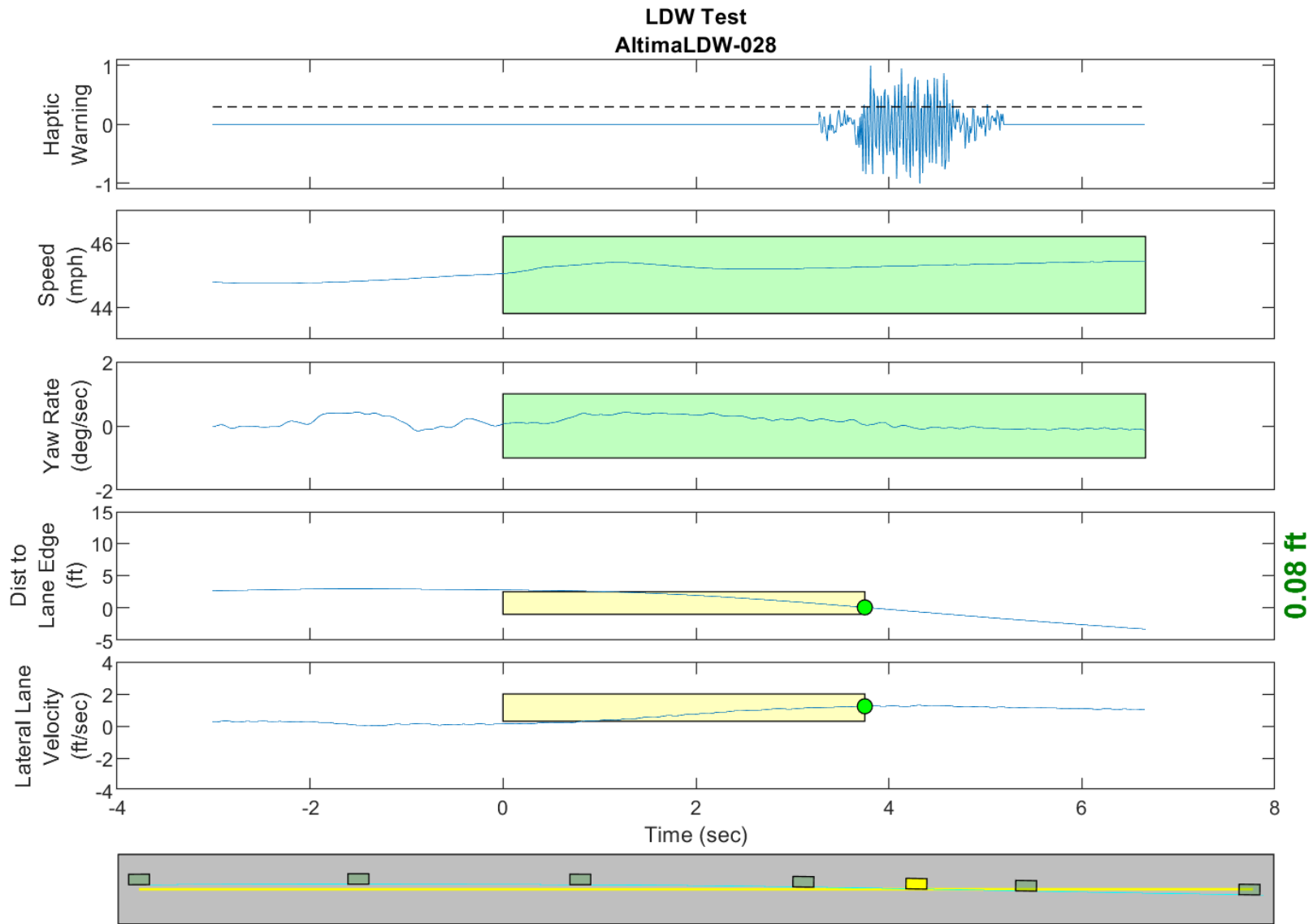

GPS Fix Type: RTK Fixed

Figure D56. Time History for Run 28, Solid Line, Right Departure, Haptic Warning

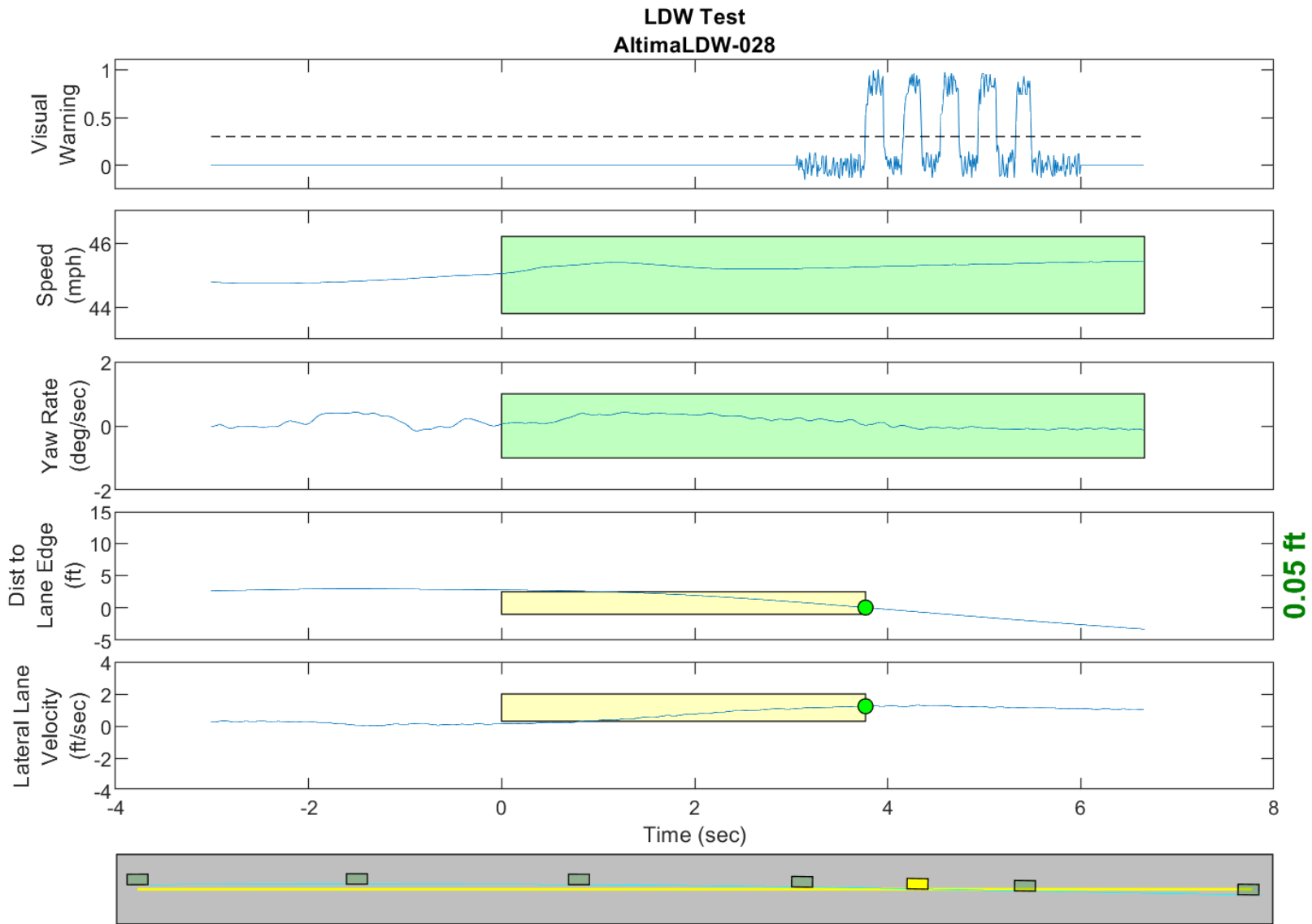

GPS Fix Type: RTK Fixed

Figure D57. Time History for Run 28, Solid Line, Right Departure, Visual Warning

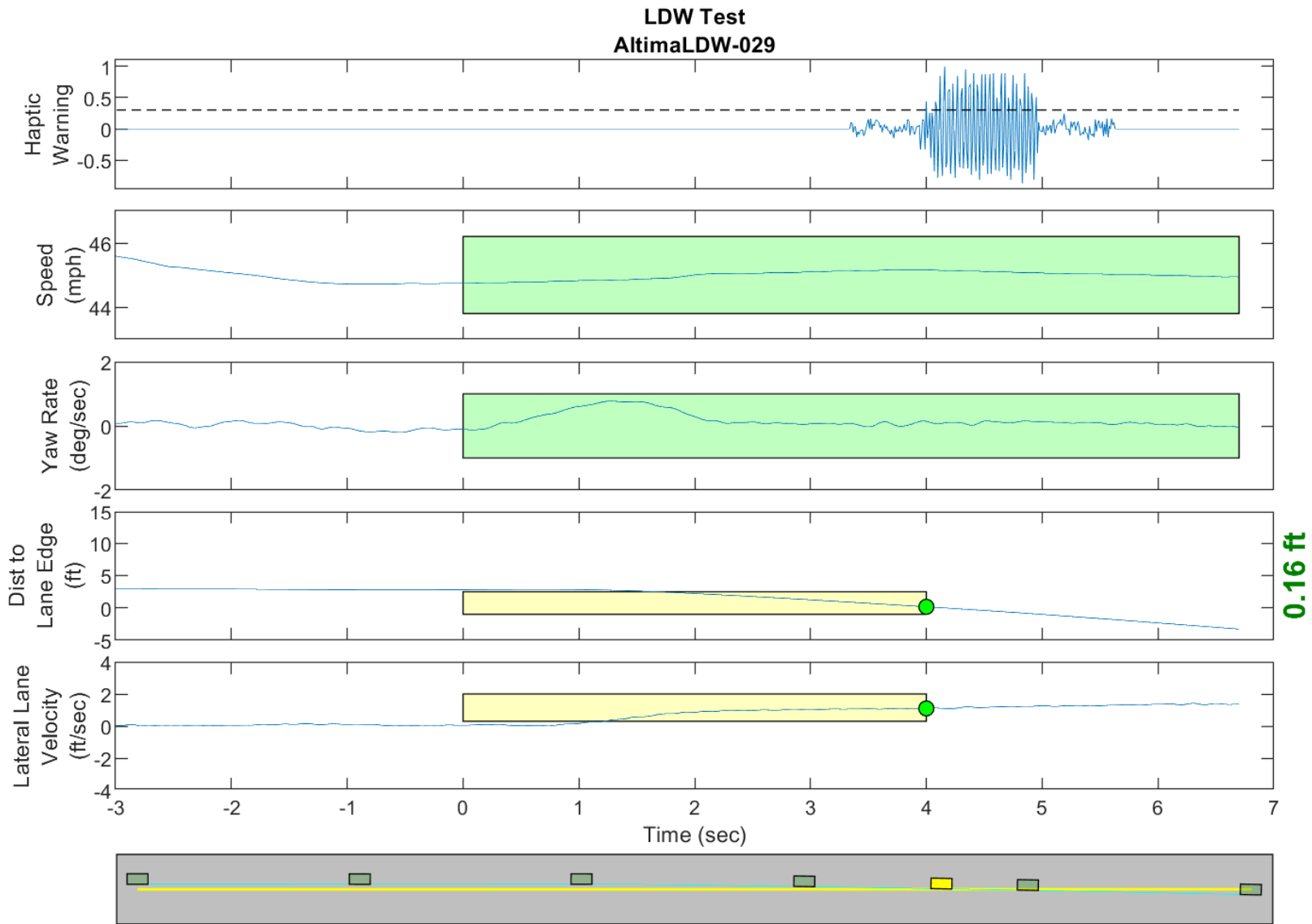

GPS Fix Type: RTK Fixed

Figure D58. Time History for Run 29, Solid Line, Right Departure, Haptic Warning

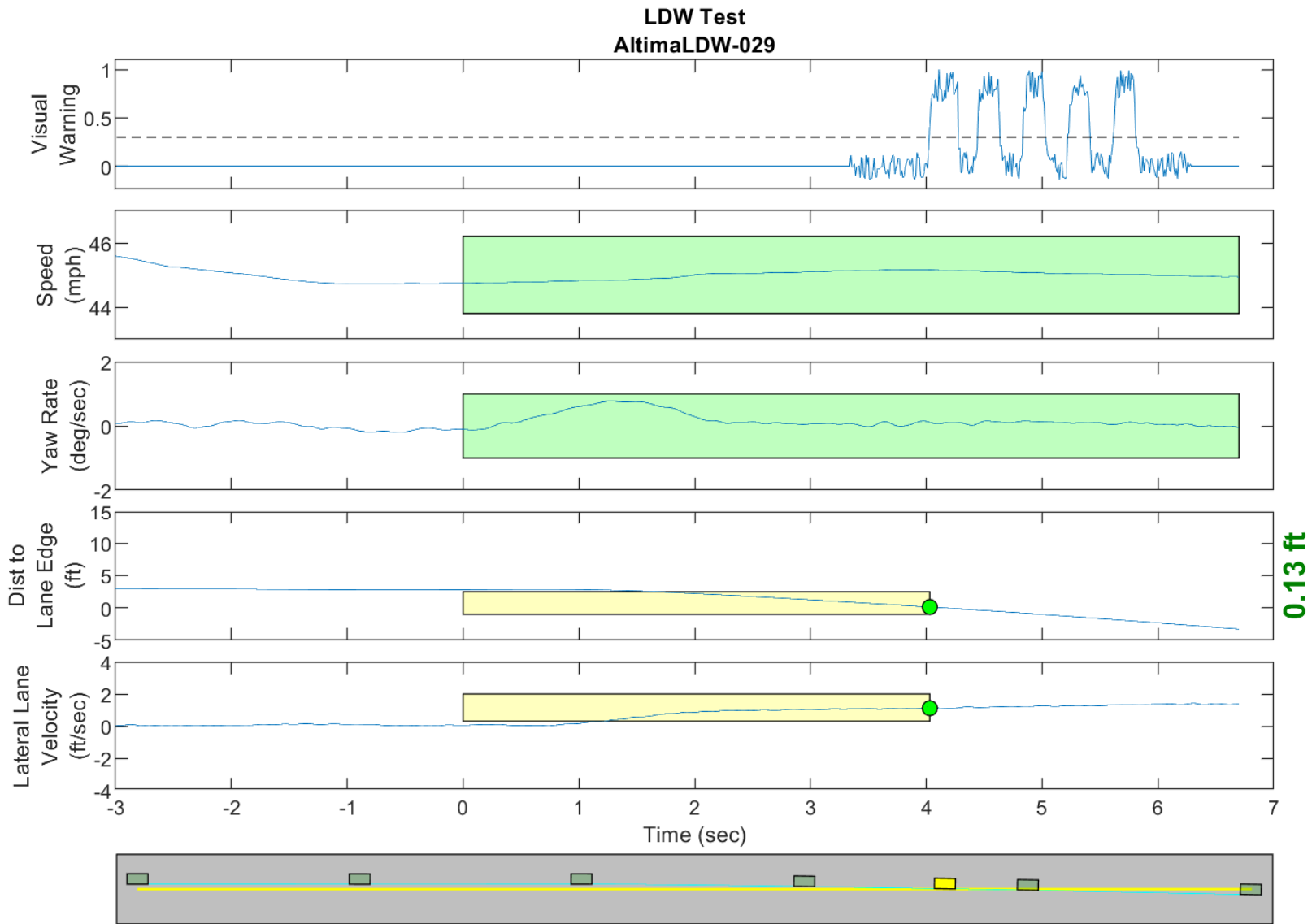

GPS Fix Type: RTK Fixed

Figure D59. Time History for Run 29, Solid Line, Right Departure, Visual Warning

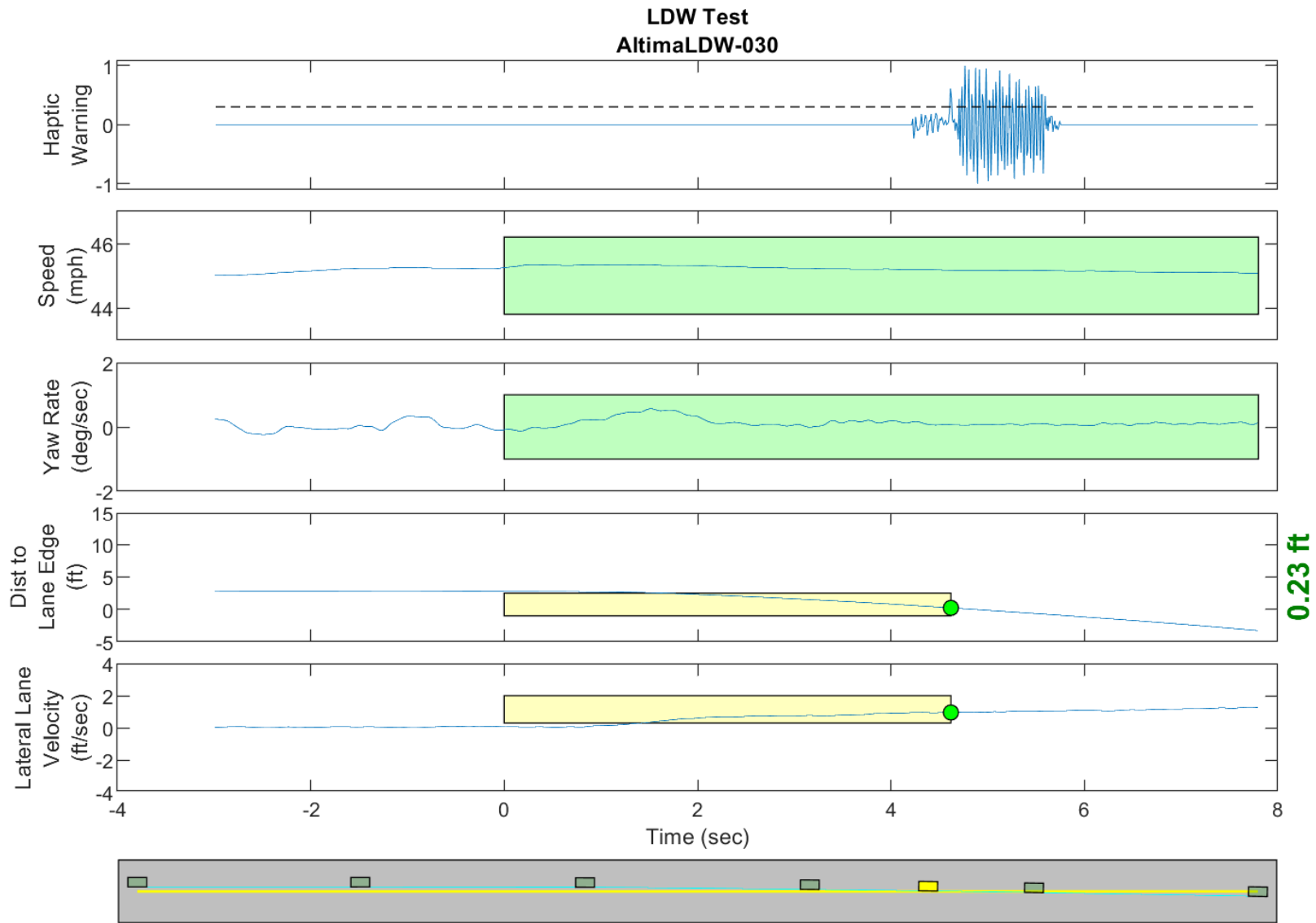

GPS Fix Type: RTK Fixed

Figure D60. Time History for Run 30, Dashed Line, Right Departure, Haptic Warning

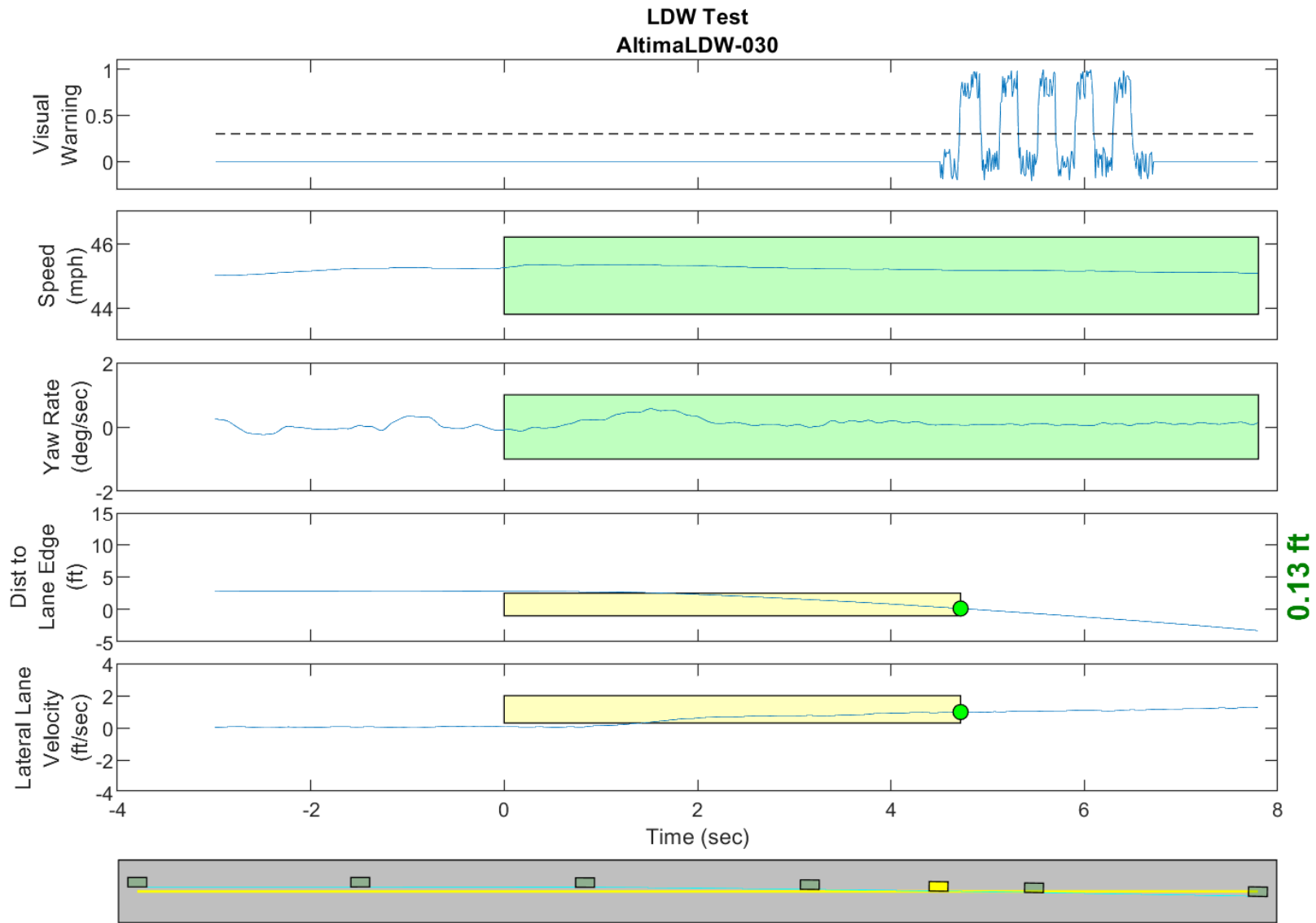

GPS Fix Type: RTK Fixed

Figure D61. Time History for Run 30, Dashed Line, Right Departure, Visual Warning

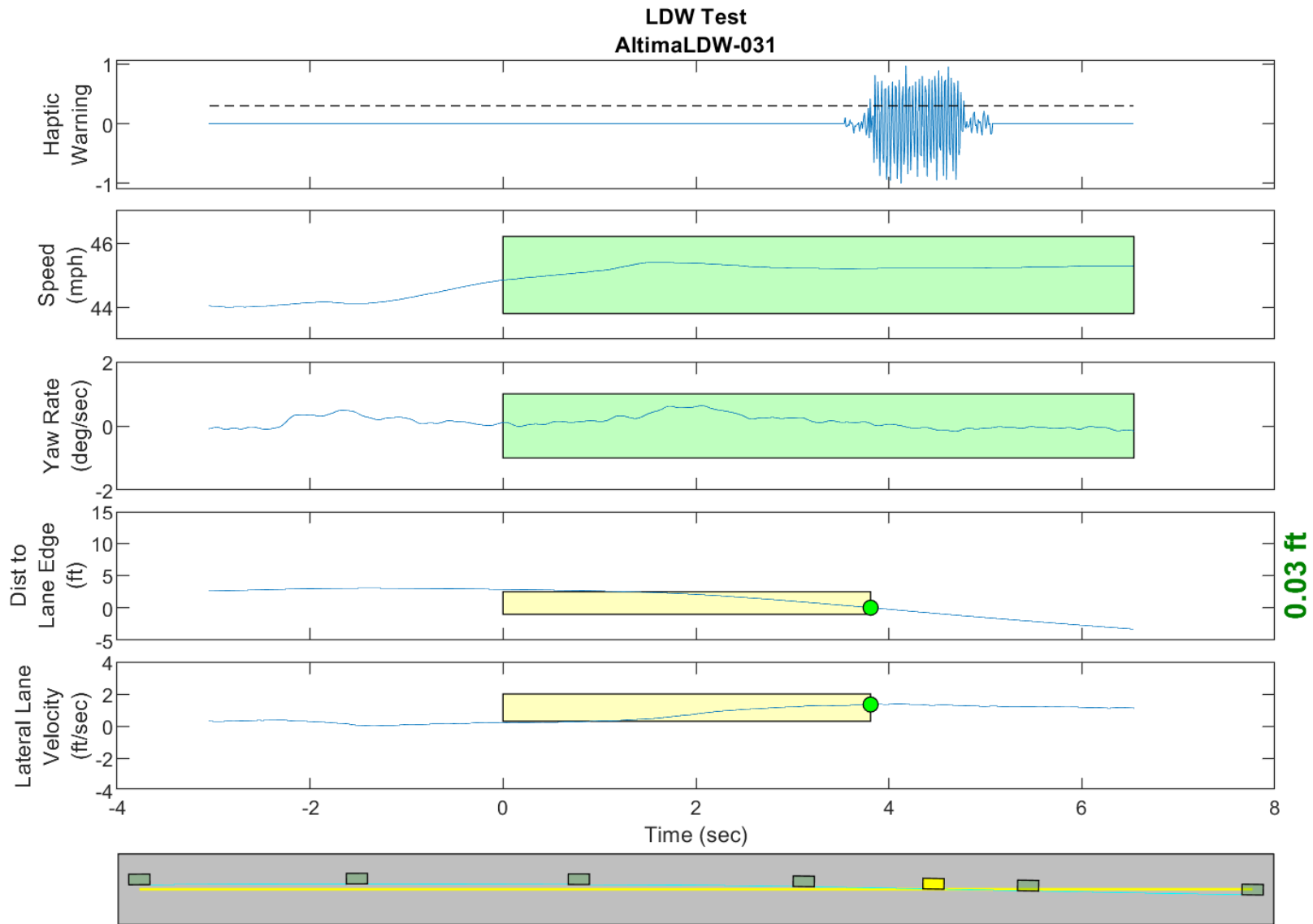

GPS Fix Type: RTK Fixed

Figure D62. Time History for Run 31, Dashed Line, Right Departure, Haptic Warning

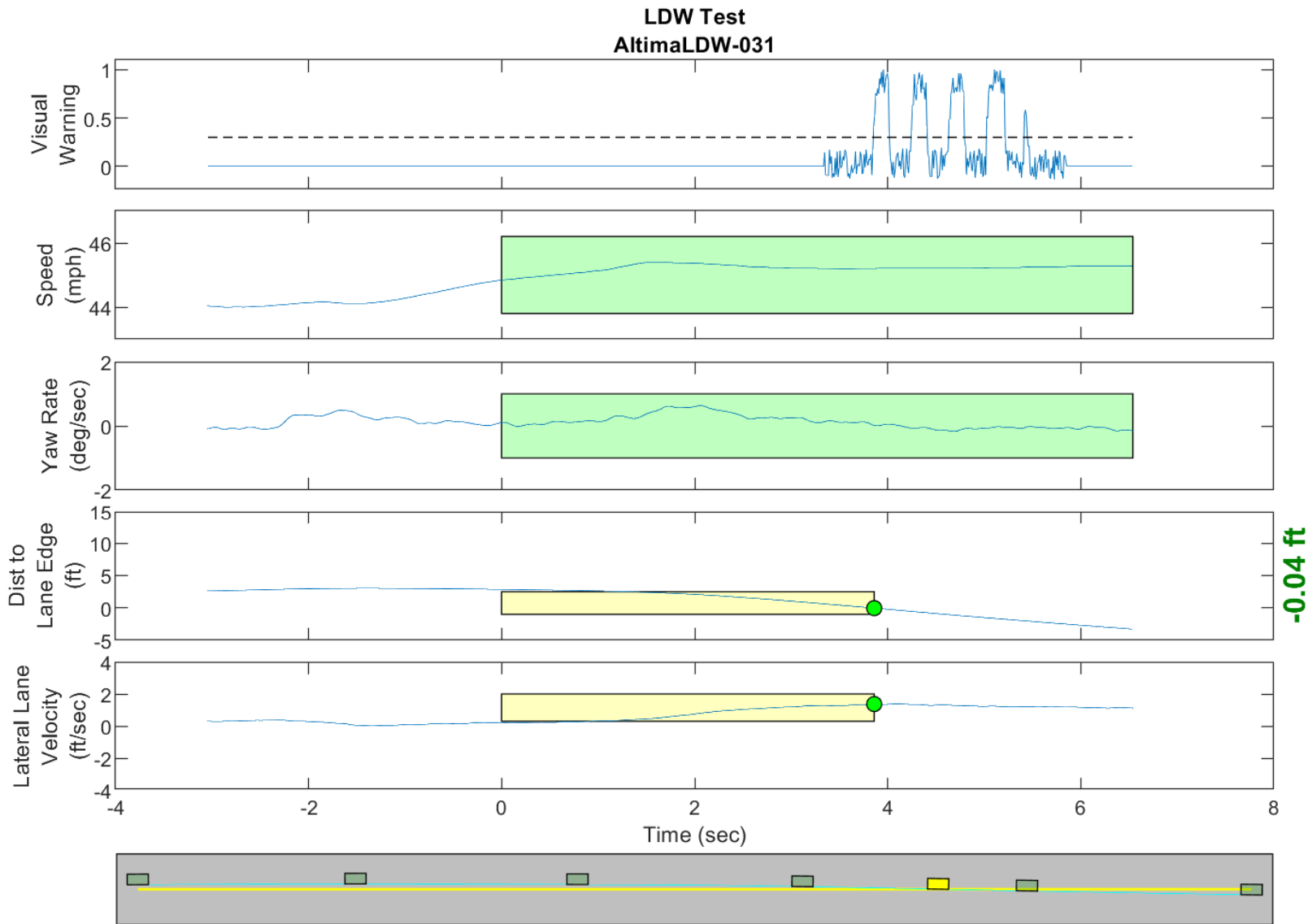

GPS Fix Type: RTK Fixed

Figure D63. Time History for Run 31, Dashed Line, Right Departure, Visual Warning

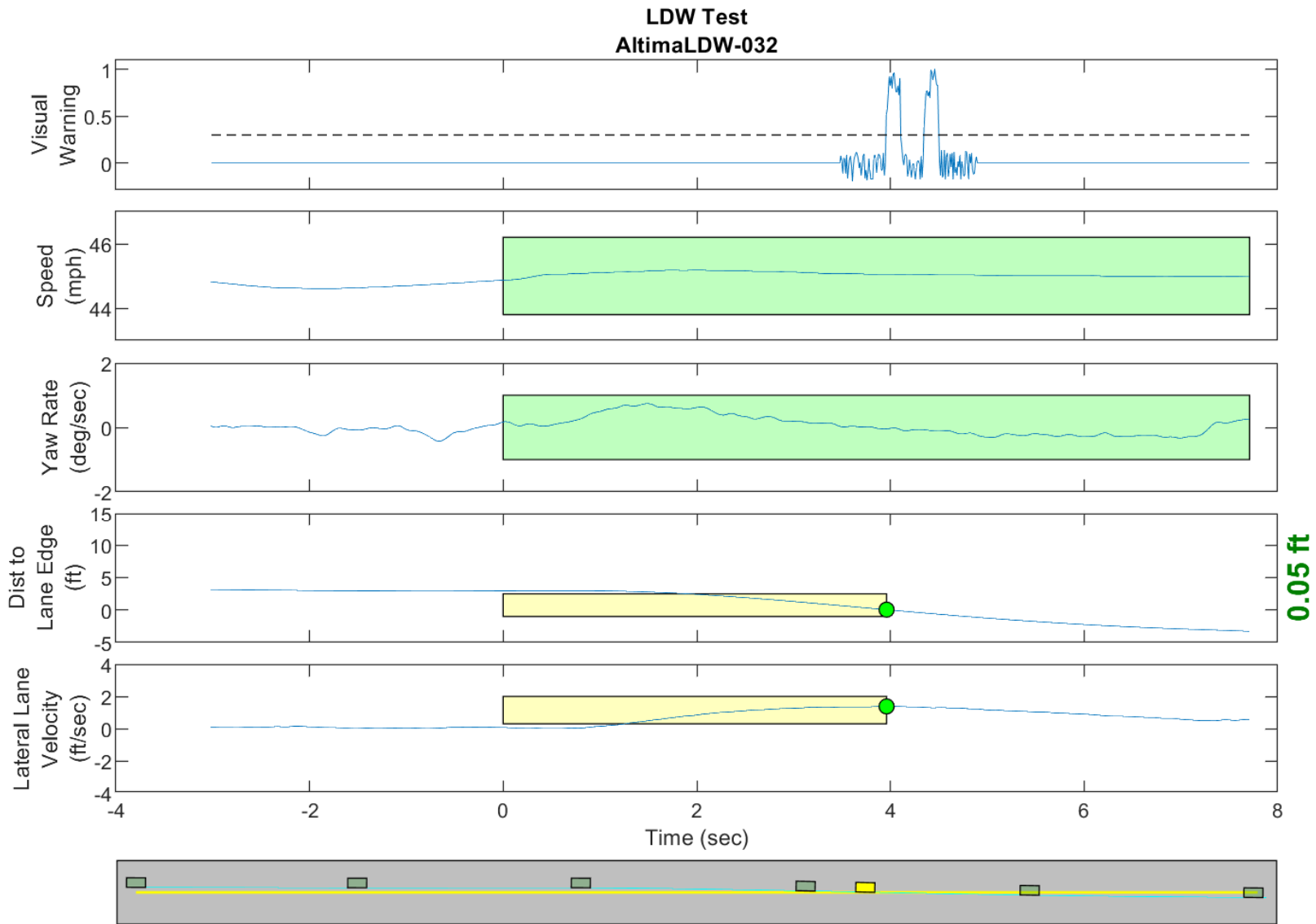

GPS Fix Type: RTK Fixed

Figure D64. Time History for Run 32, Dashed Line, Right Departure, Visual Warning

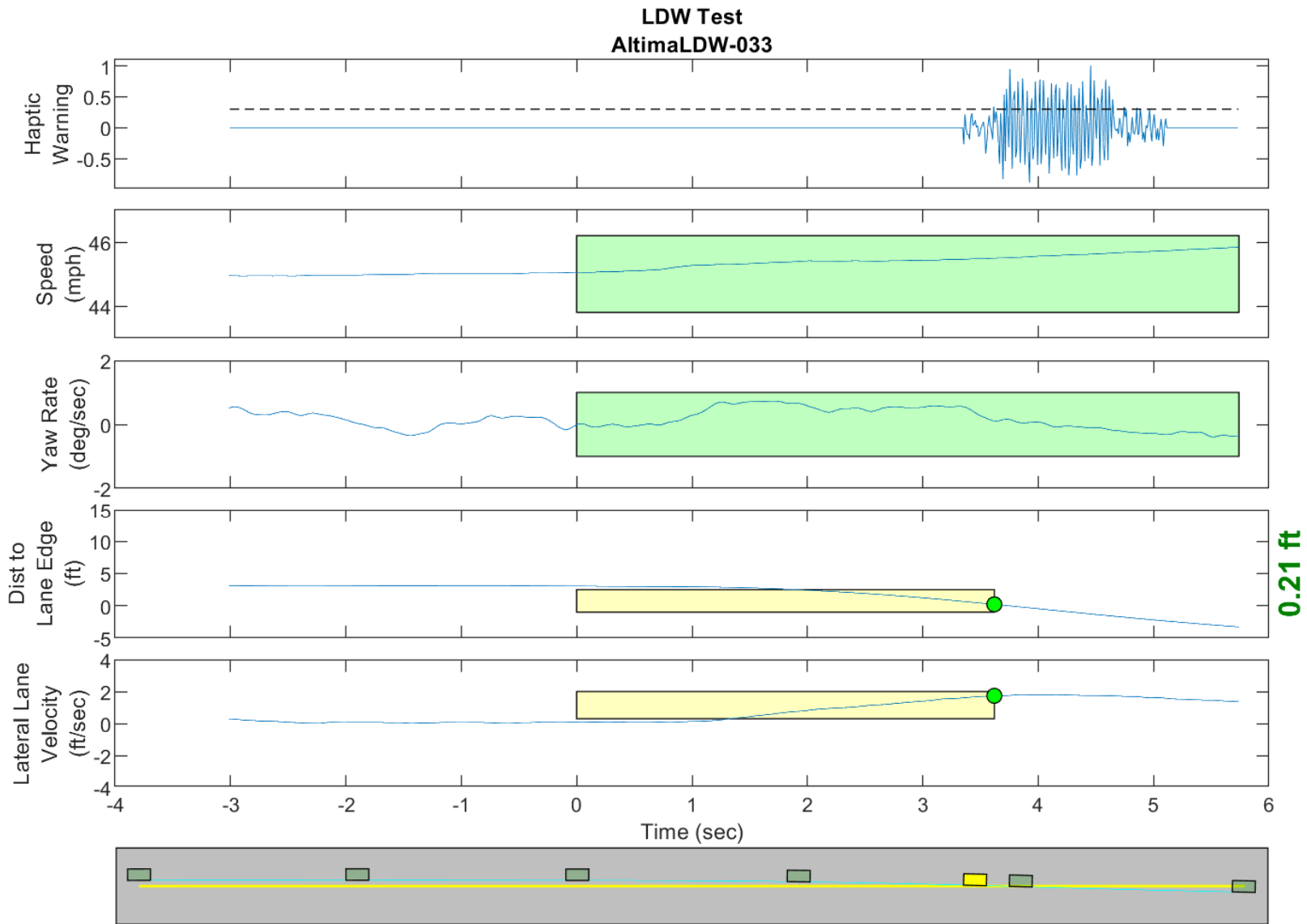

GPS Fix Type: RTK Fixed

Figure D65. Time History for Run 33, Dashed Line, Right Departure, Haptic Warning

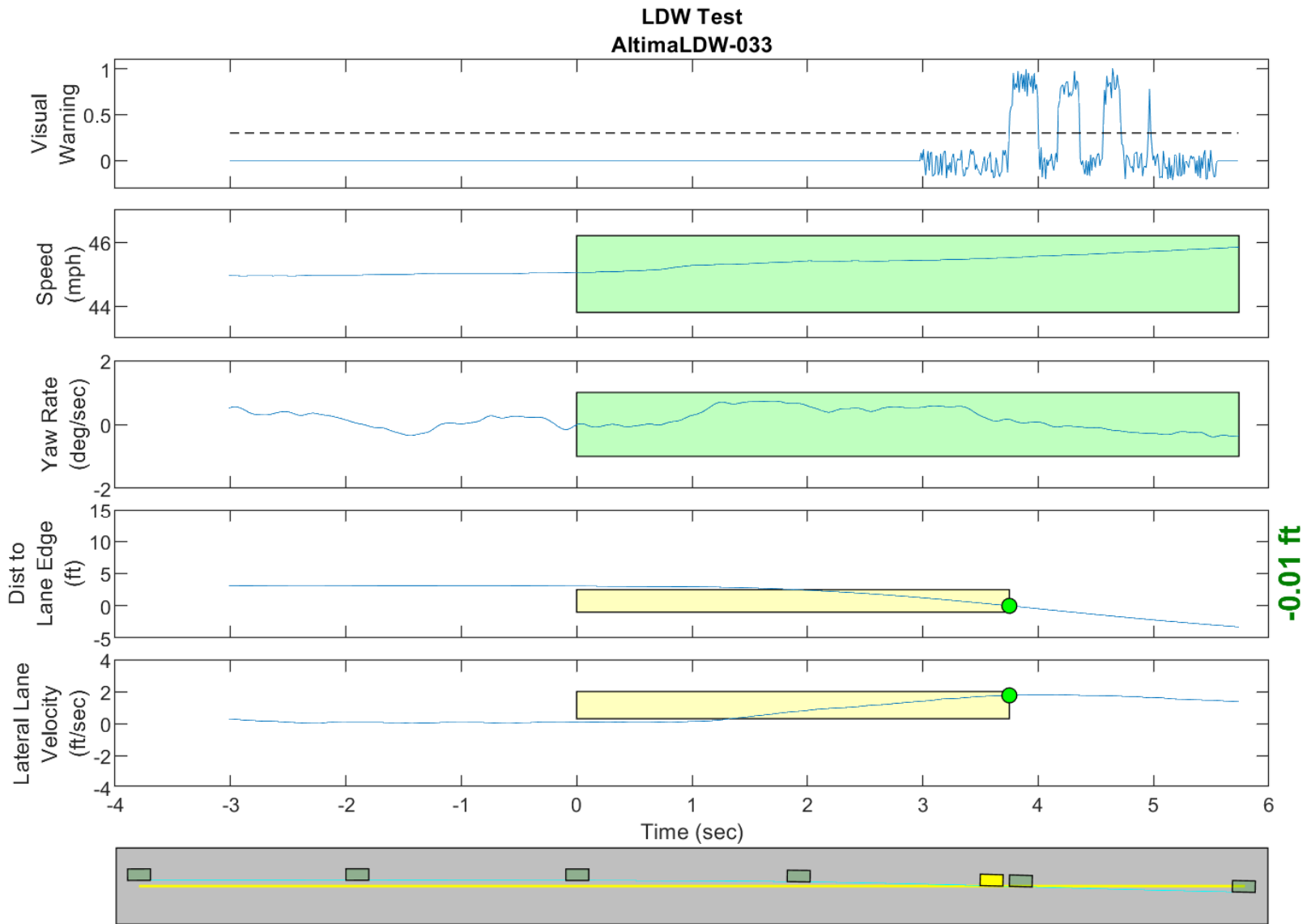

GPS Fix Type: RTK Fixed

Figure D66. Time History for Run 33, Dashed Line, Right Departure, Visual Warning

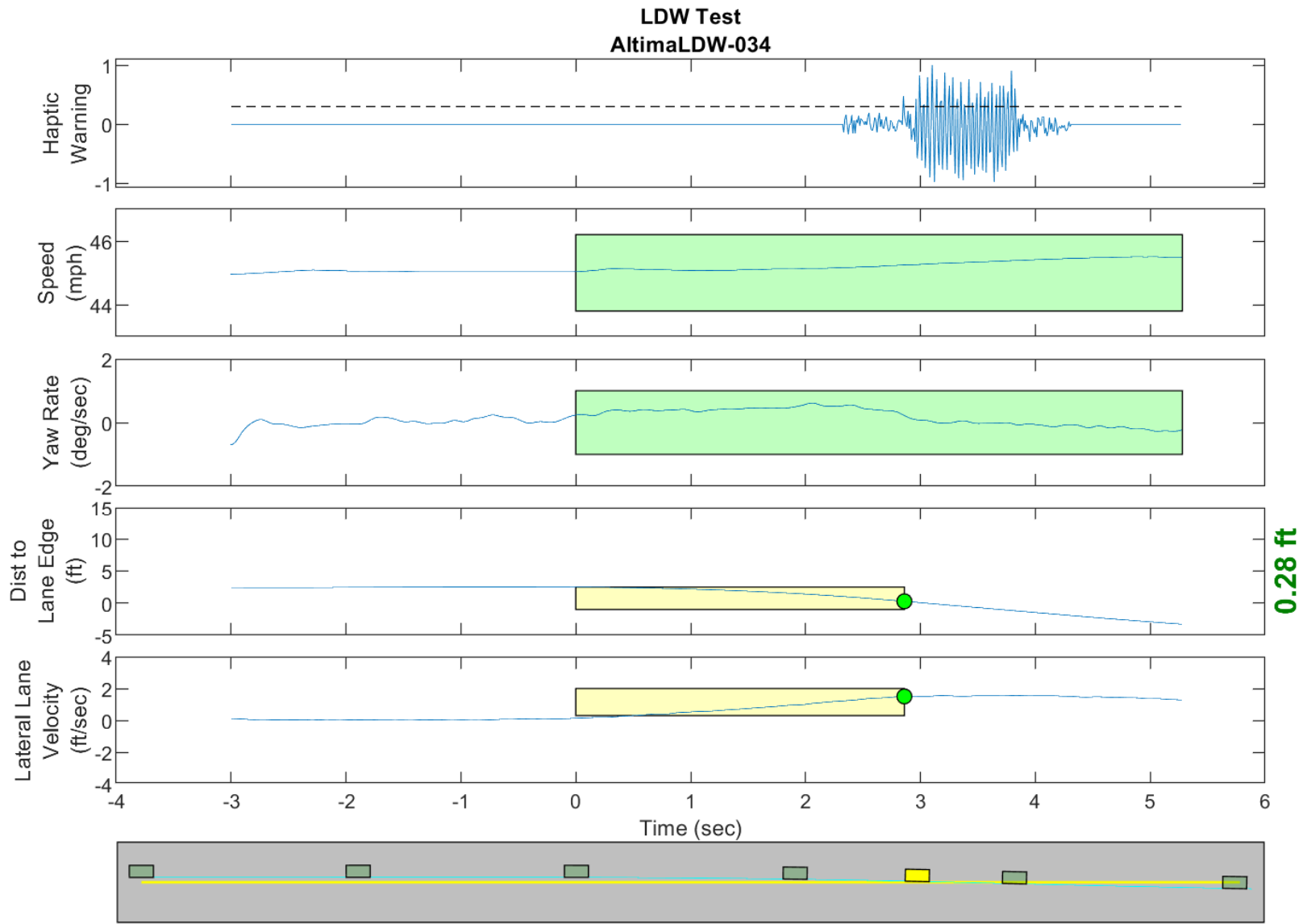

GPS Fix Type: RTK Fixed

Figure D67. Time History for Run 34, Dashed Line, Right Departure, Haptic Warning

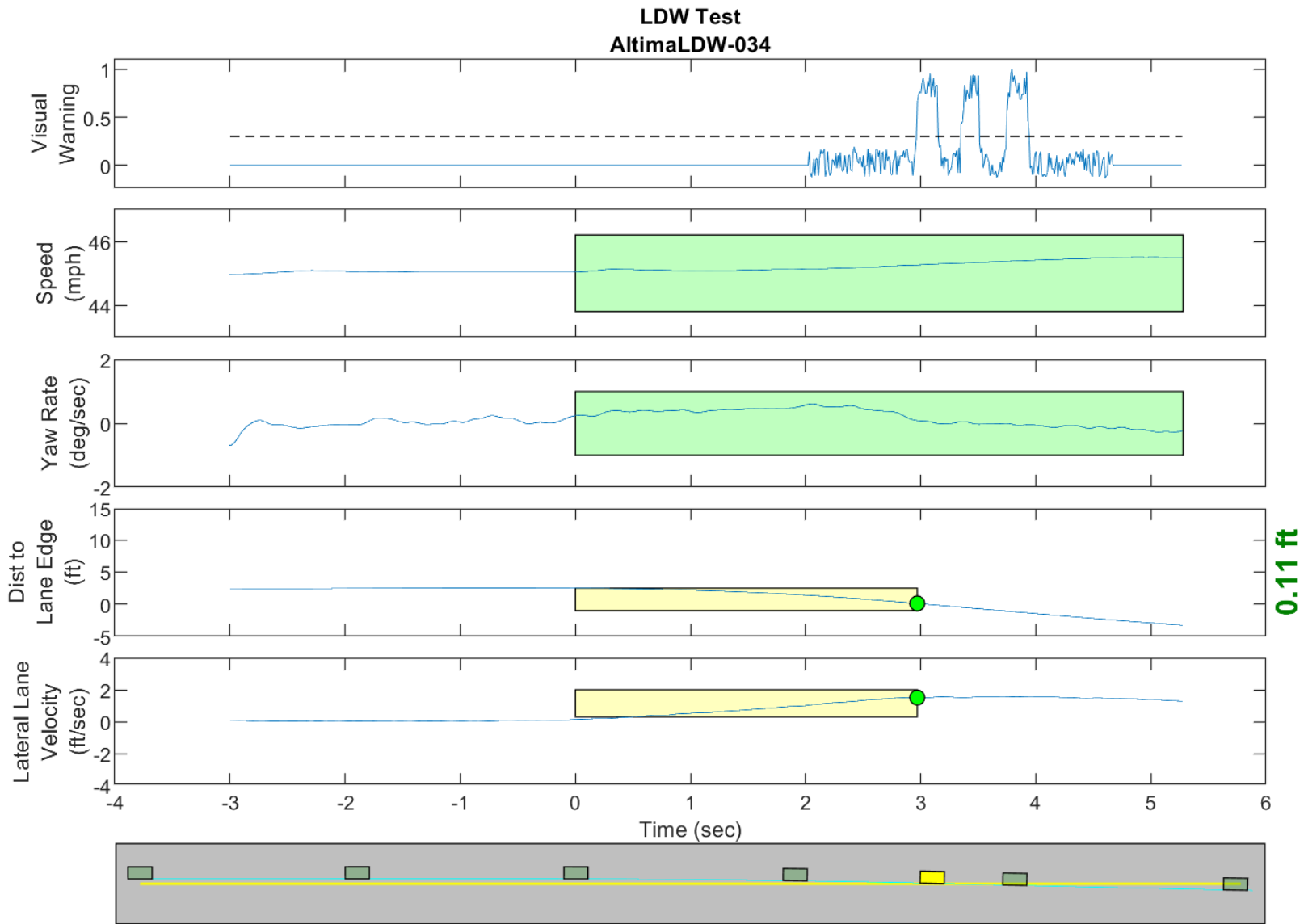

GPS Fix Type: RTK Fixed

Figure D68. Time History for Run 34, Dashed Line, Right Departure, Visual Warning

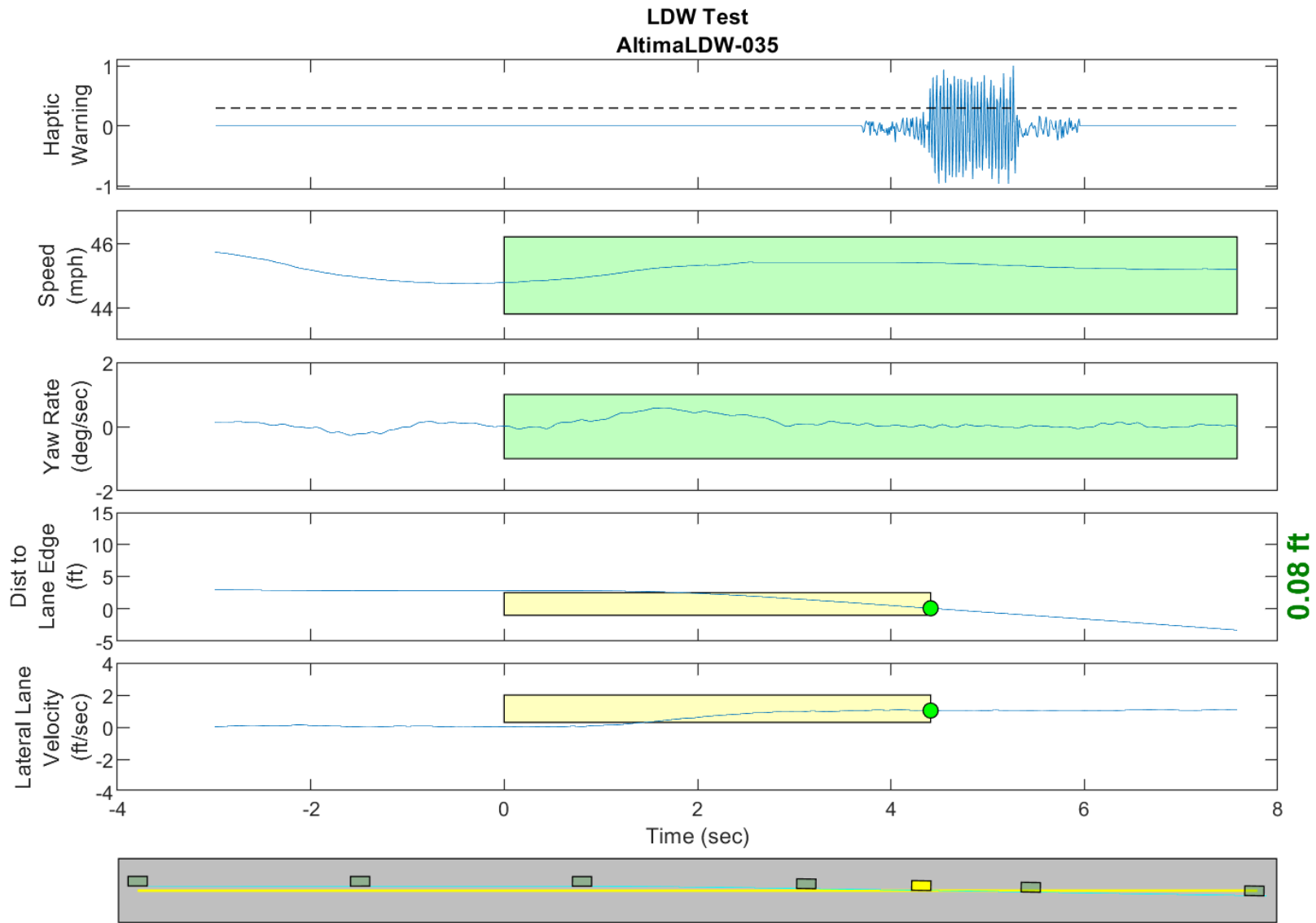

GPS Fix Type: RTK Fixed

Figure D69. Time History for Run 35, Dashed Line, Right Departure, Haptic Warning

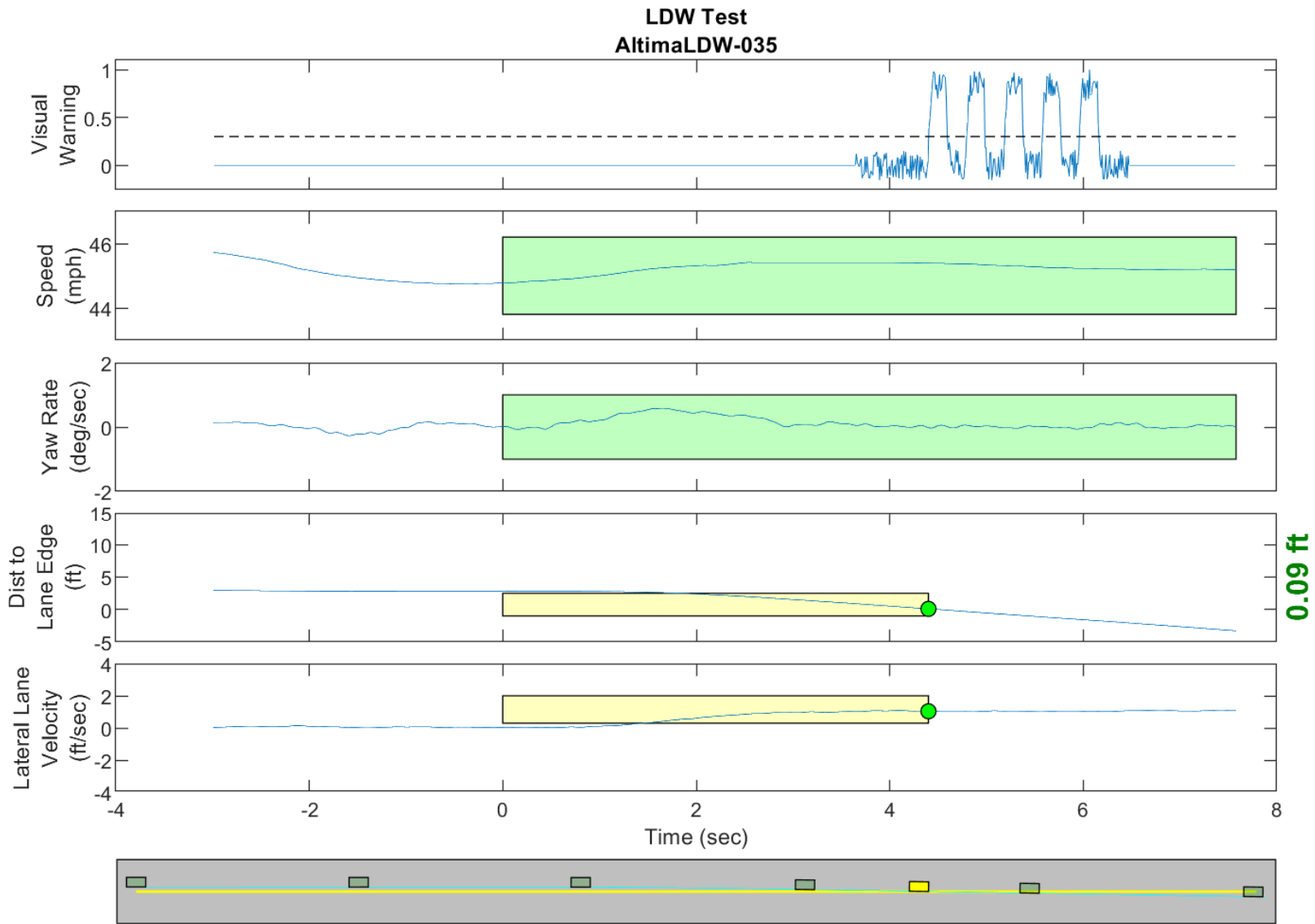

GPS Fix Type: RTK Fixed

Figure D70. Time History for Run 35, Dashed Line, Right Departure, Visual Warning

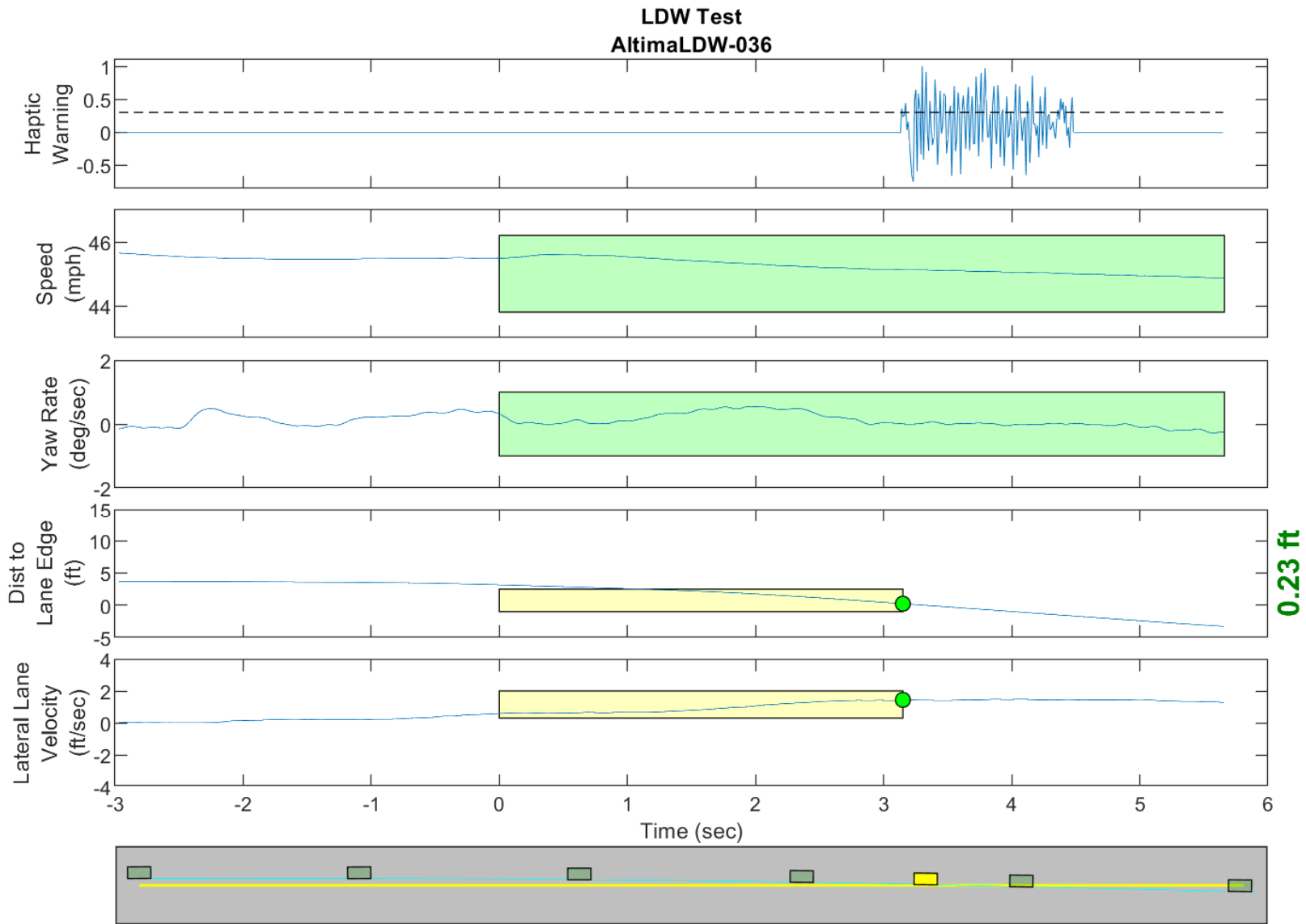

GPS Fix Type: RTK Fixed

Figure D71. Time History for Run 36, Dashed Line, Right Departure, Haptic Warning

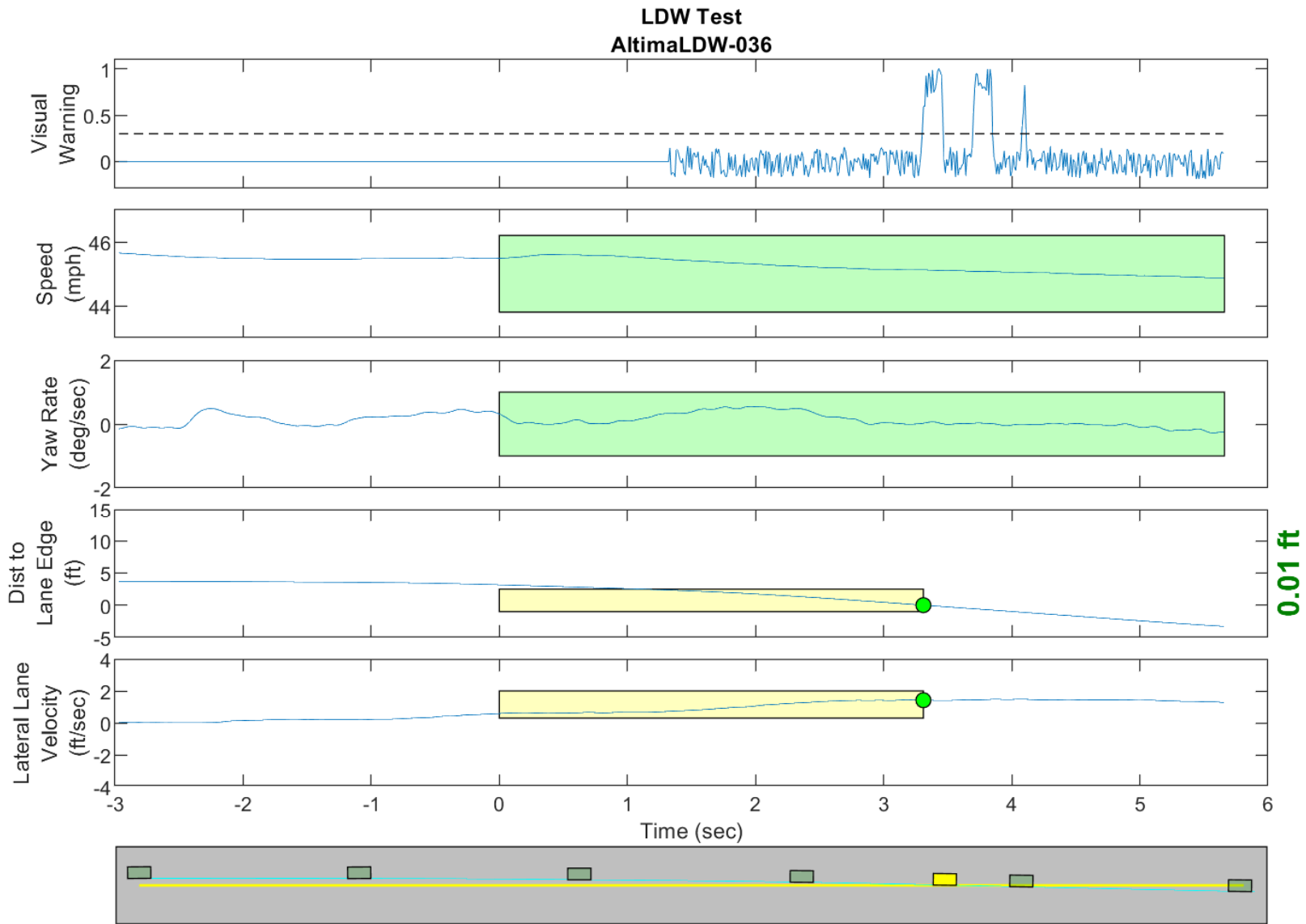

GPS Fix Type: RTK Fixed

Figure D72. Time History for Run 36, Dashed Line, Right Departure, Visual Warning

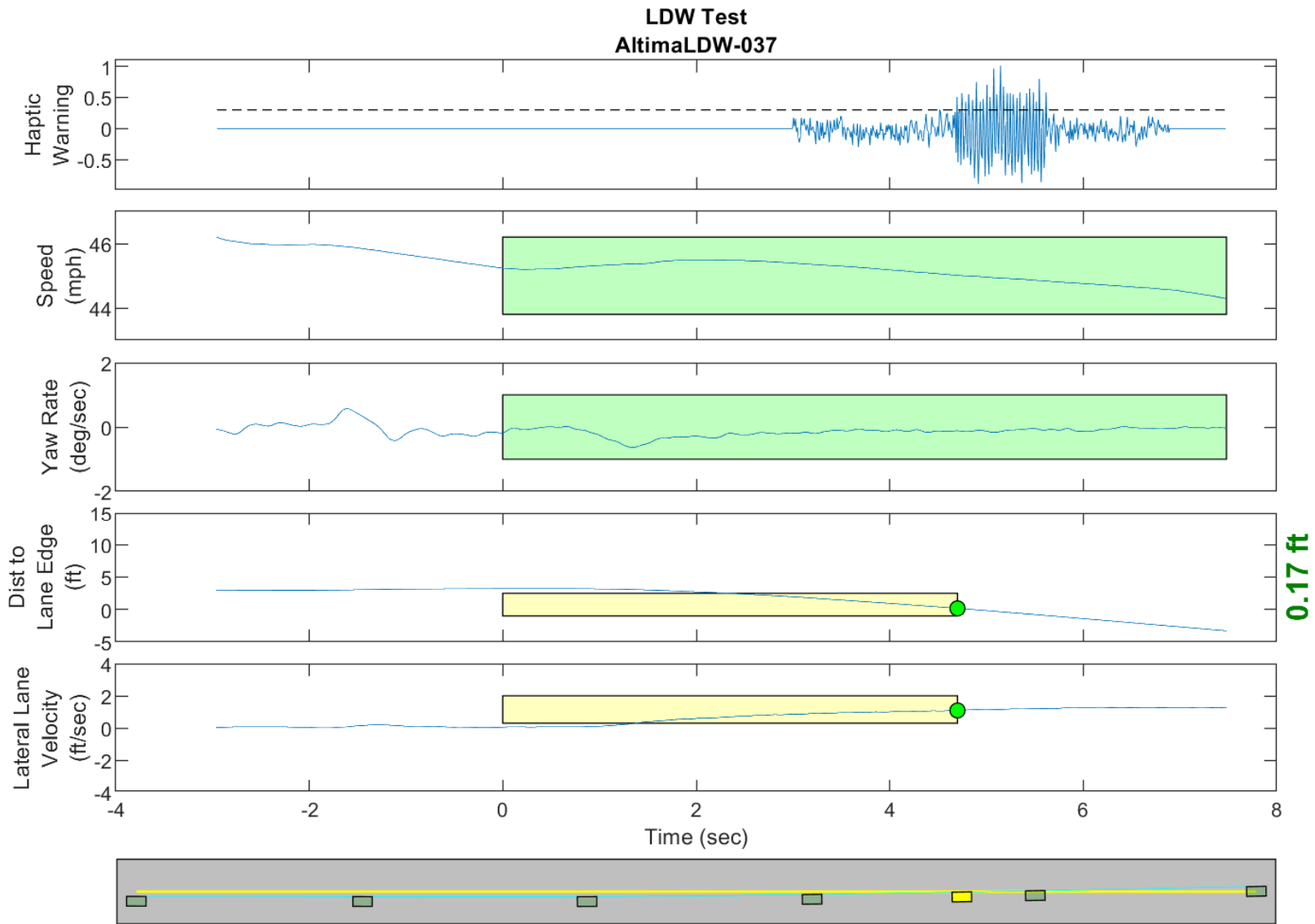

GPS Fix Type: RTK Fixed

Figure D73. Time History for Run 37, Dashed Line, Left Departure, Haptic Warning

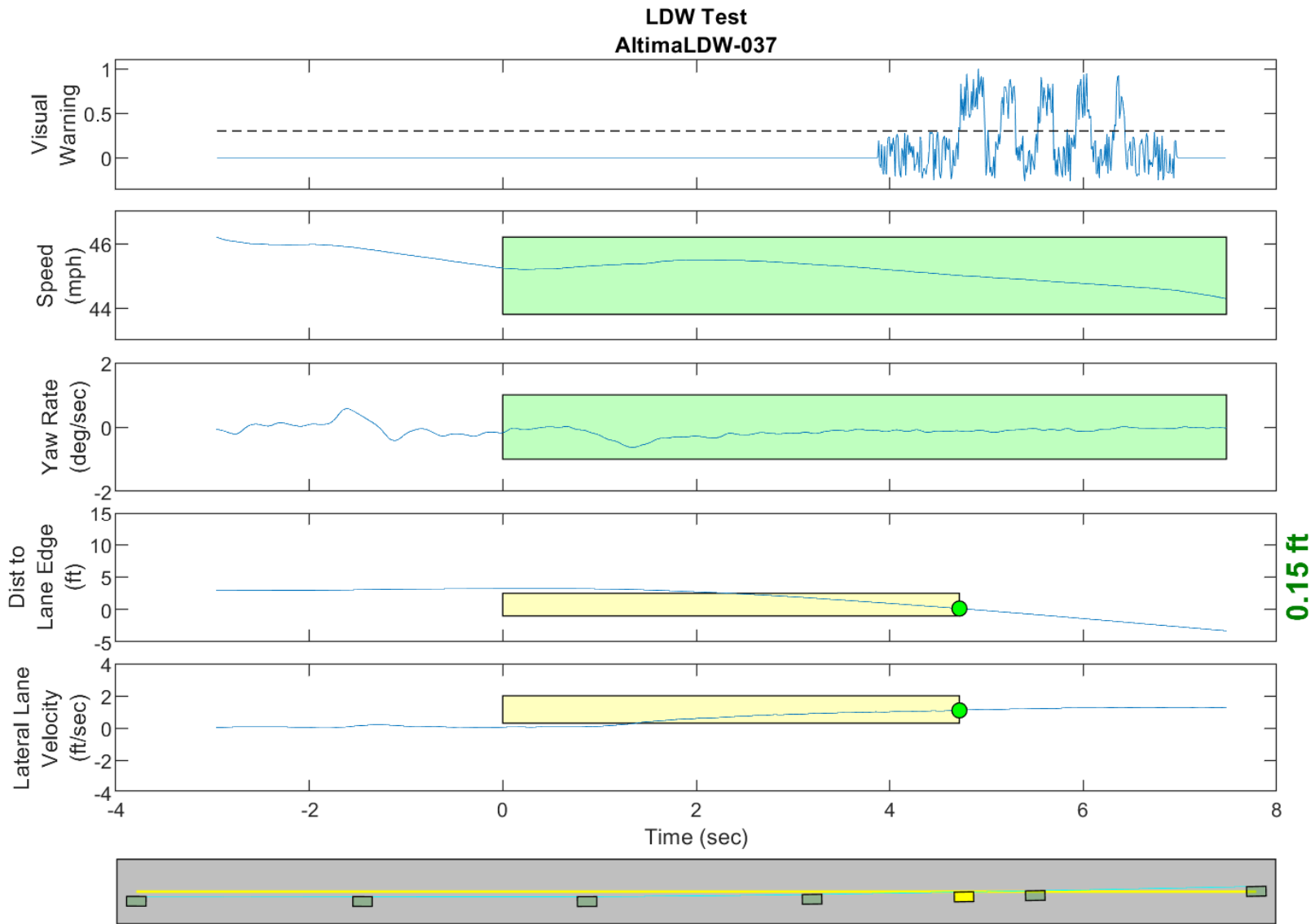

GPS Fix Type: RTK Fixed

Figure D74. Time History for Run 37, Dashed Line, Left Departure, Visual Warning

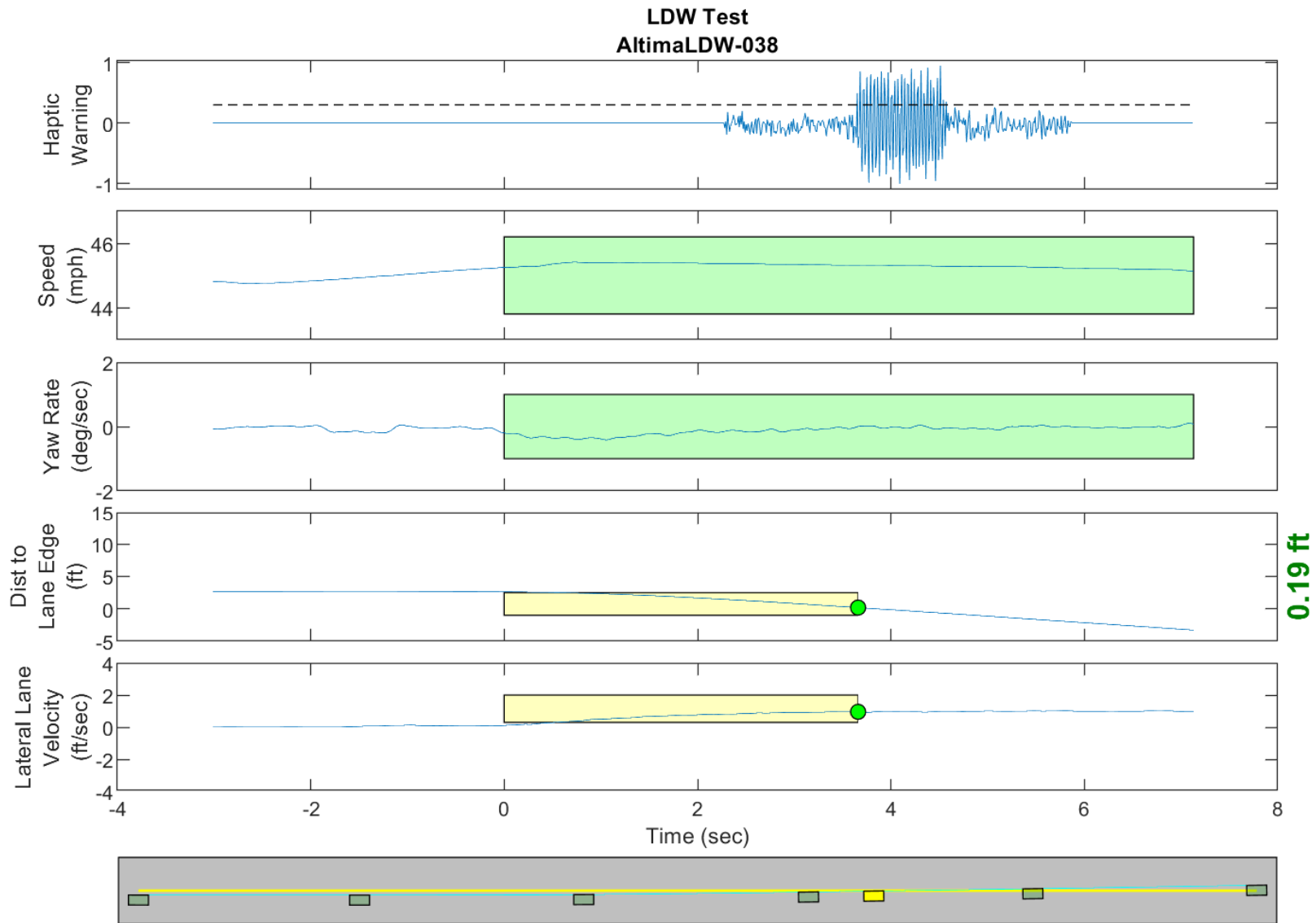

GPS Fix Type: RTK Fixed

Figure D75. Time History for Run 38, Dashed Line, Left Departure, Haptic Warning

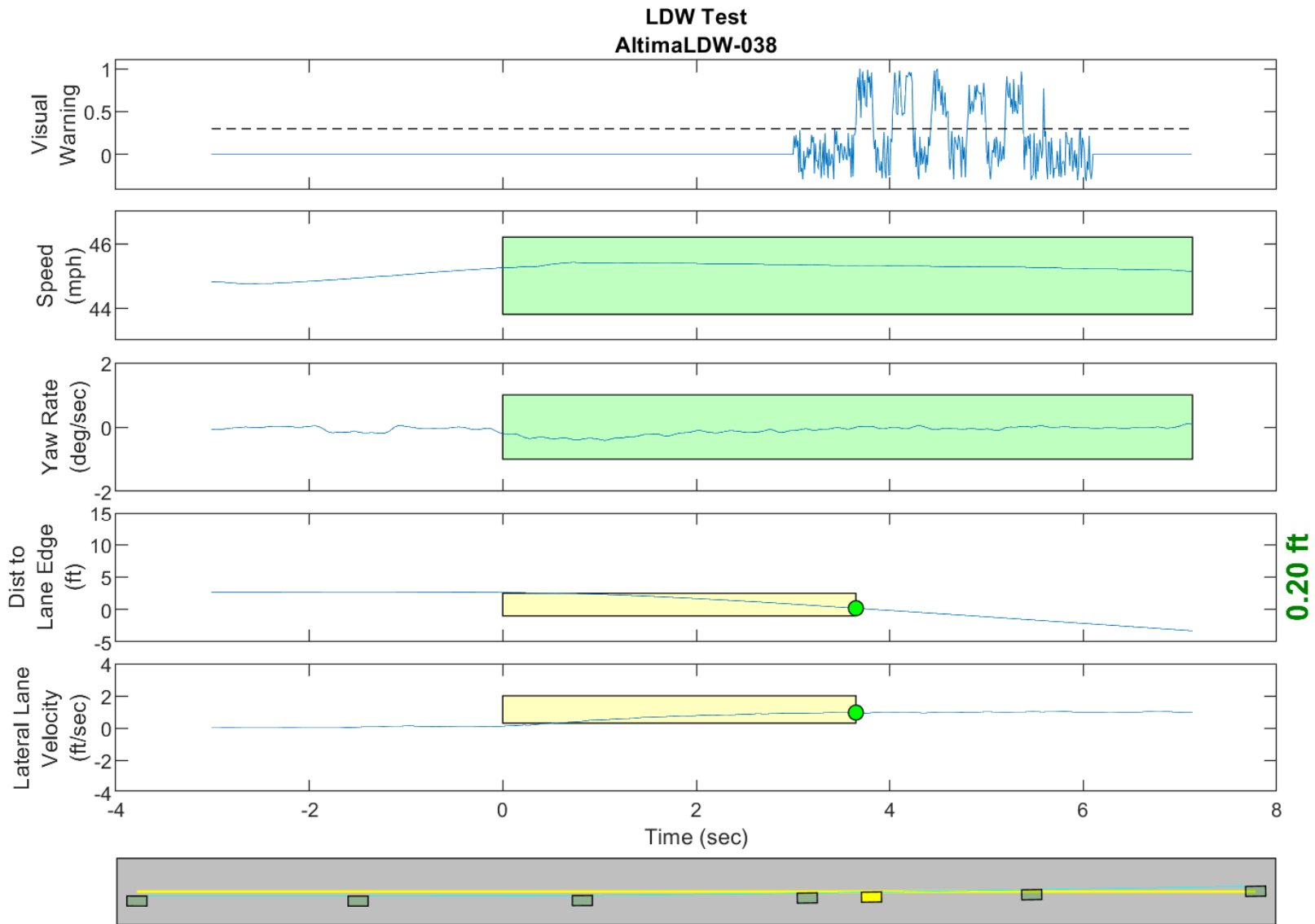

GPS Fix Type: RTK Fixed

Figure D76. Time History for Run 38, Dashed Line, Left Departure, Visual Warning

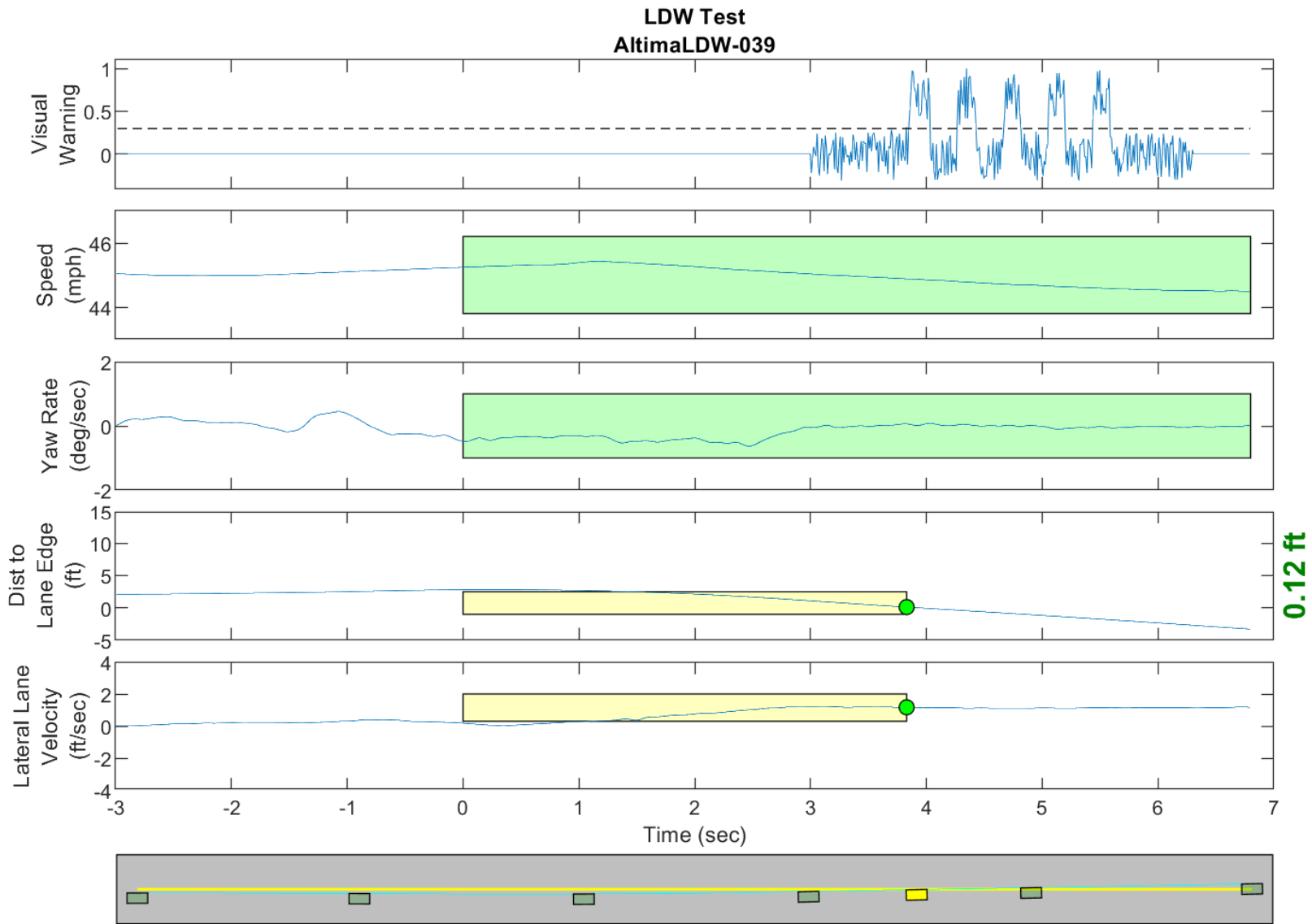

GPS Fix Type: RTK Fixed

Figure D77. Time History for Run 39, Dashed Line, Left Departure, Visual Warning

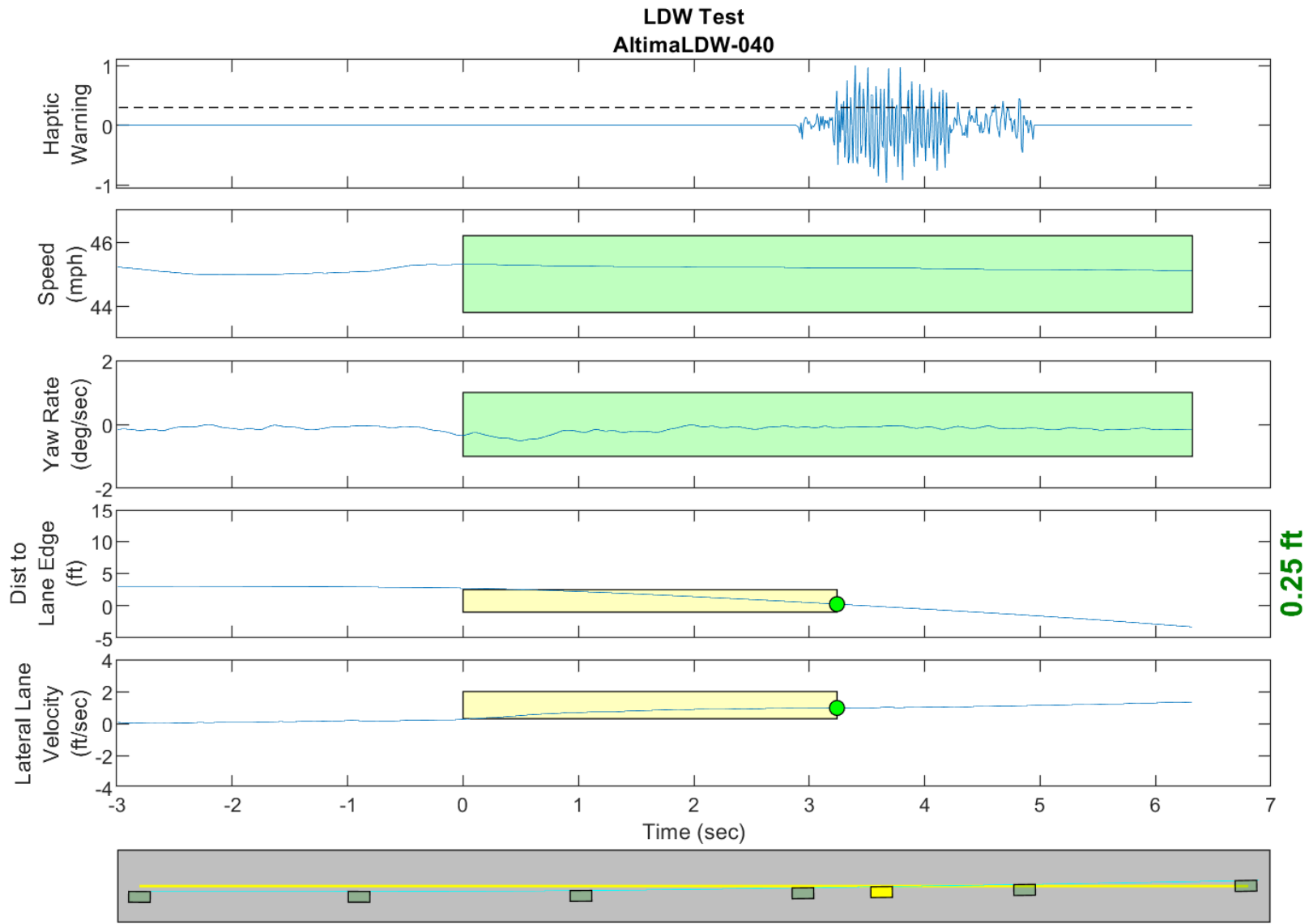

GPS Fix Type: RTK Fixed

Figure D78. Time History for Run 40, Dashed Line, Left Departure, Haptic Warning

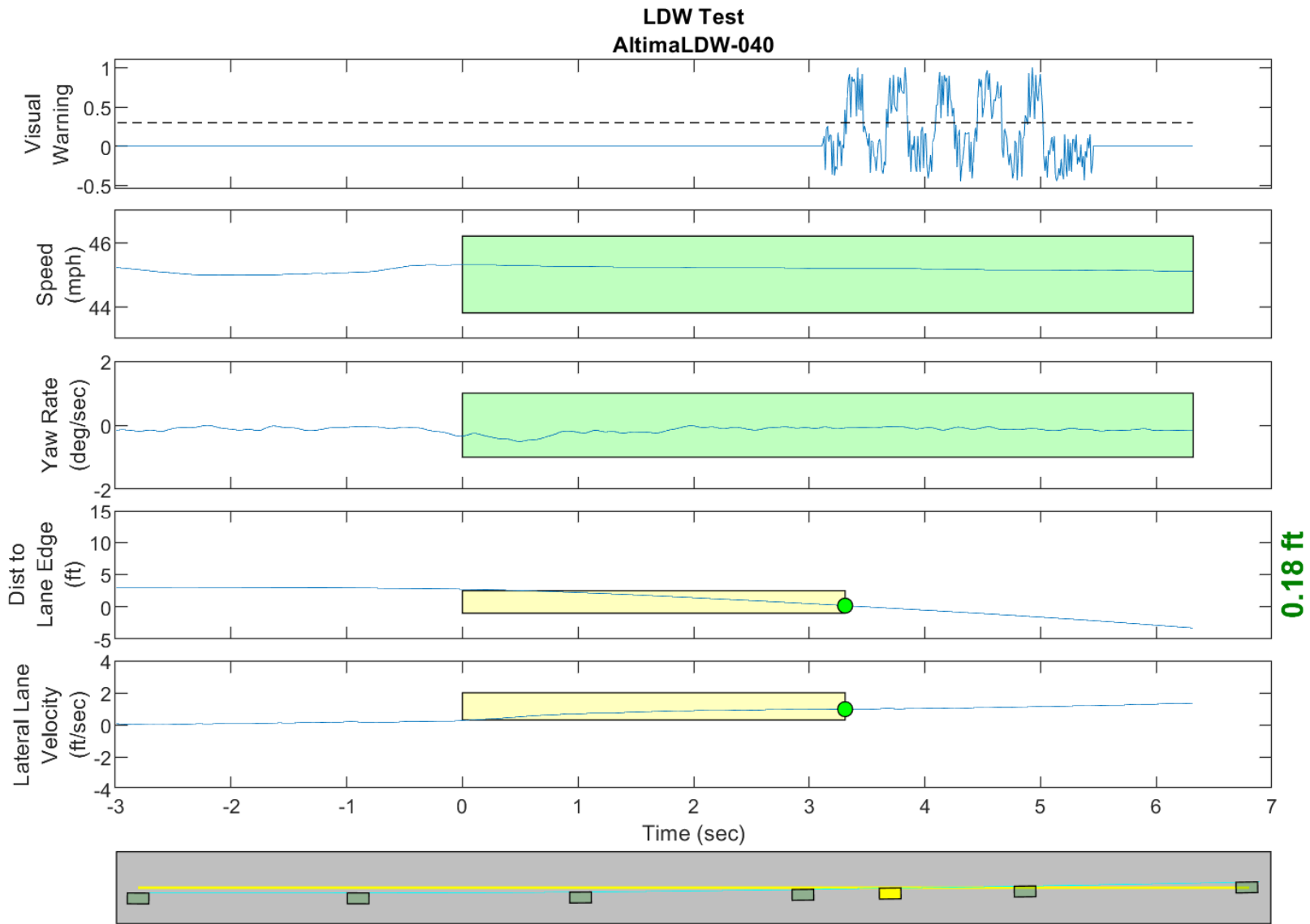

GPS Fix Type: RTK Fixed

Figure D79. Time History for Run 40, Dashed Line, Left Departure, Visual Warning

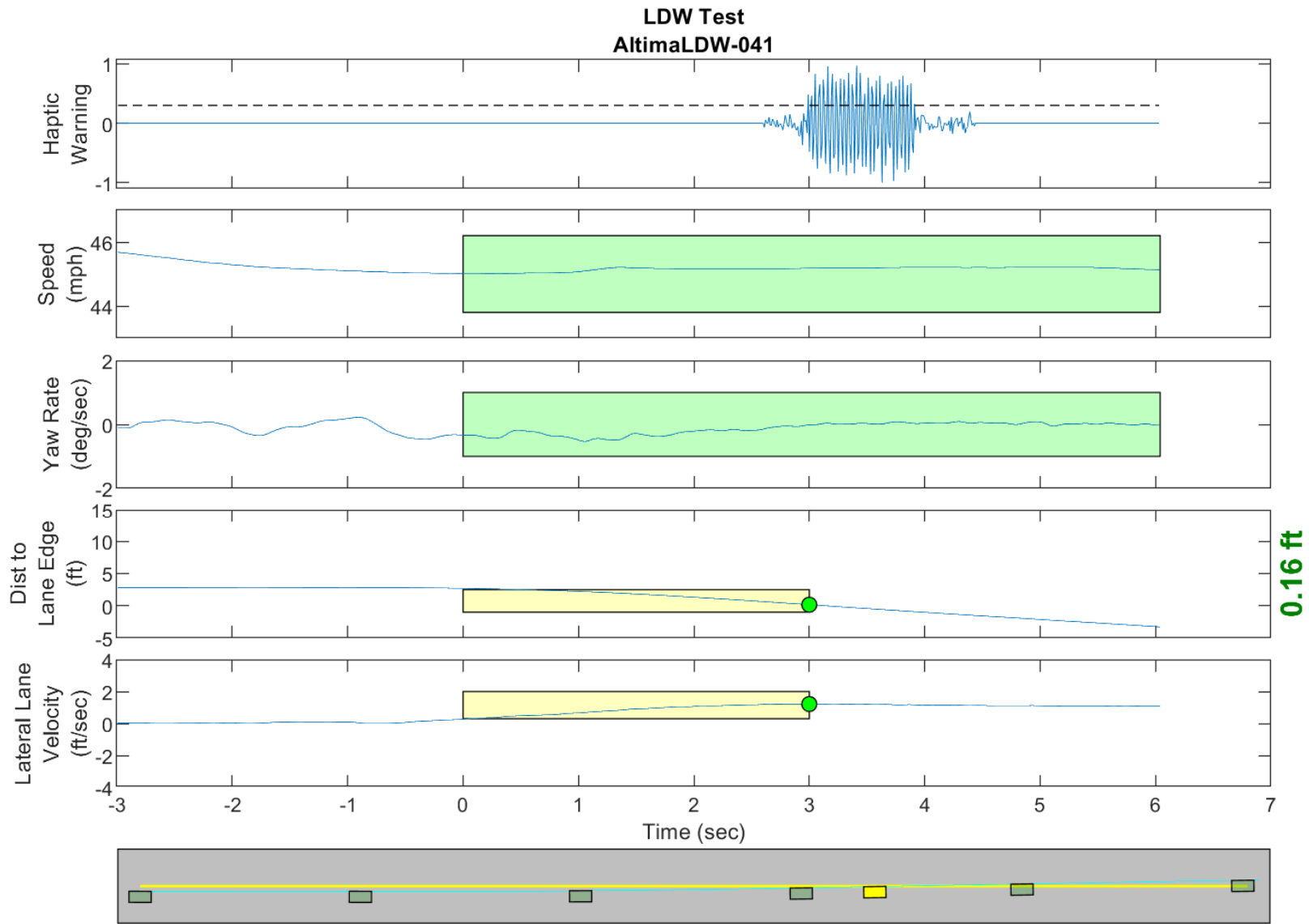

GPS Fix Type: RTK Fixed

Figure D80. Time History for Run 41, Dashed Line, Left Departure, Haptic Warning

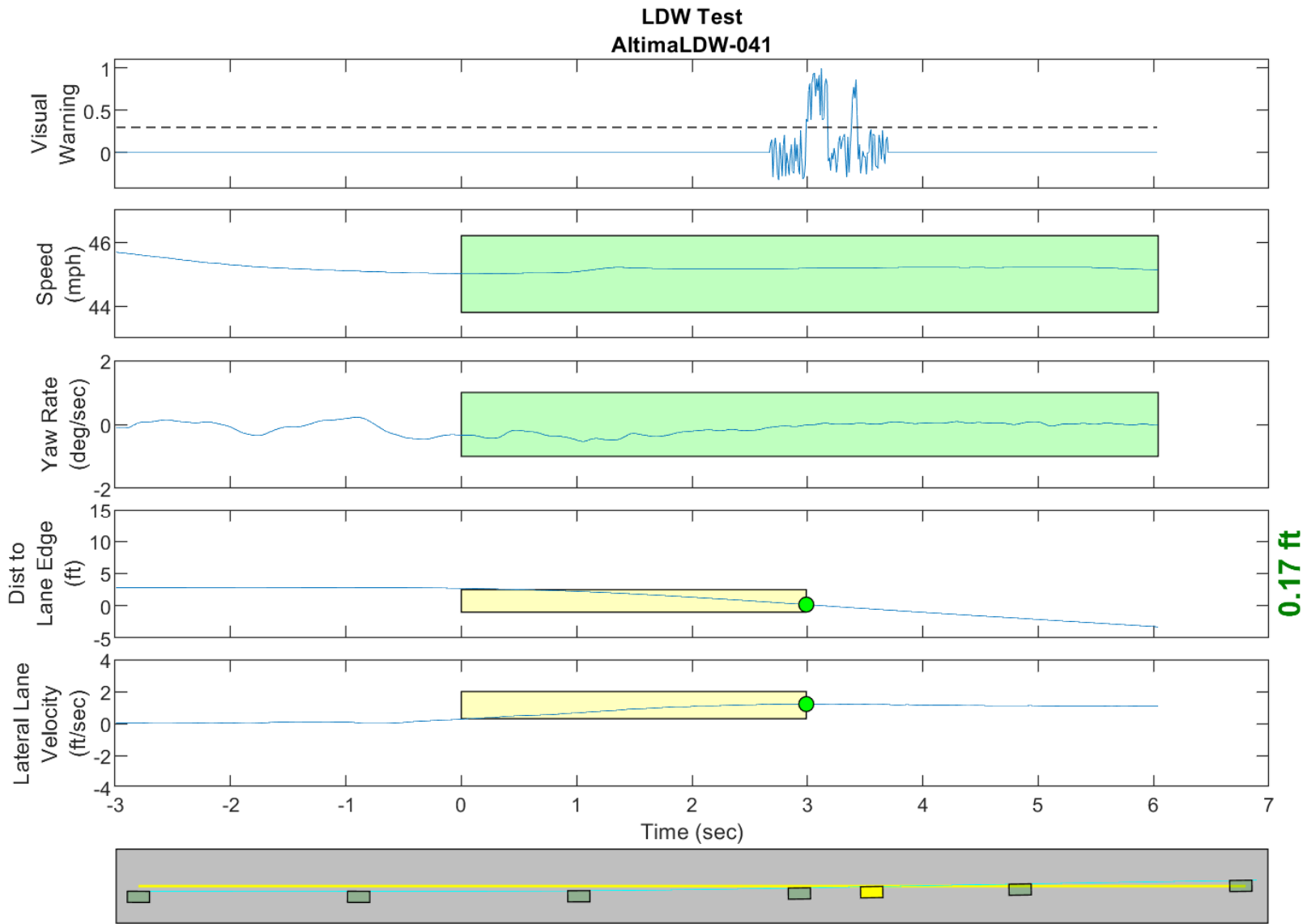

0.17 ft

GPS Fix Type: RTK Fixed

Figure D81. Time History for Run 41, Dashed Line, Left Departure, Visual Warning

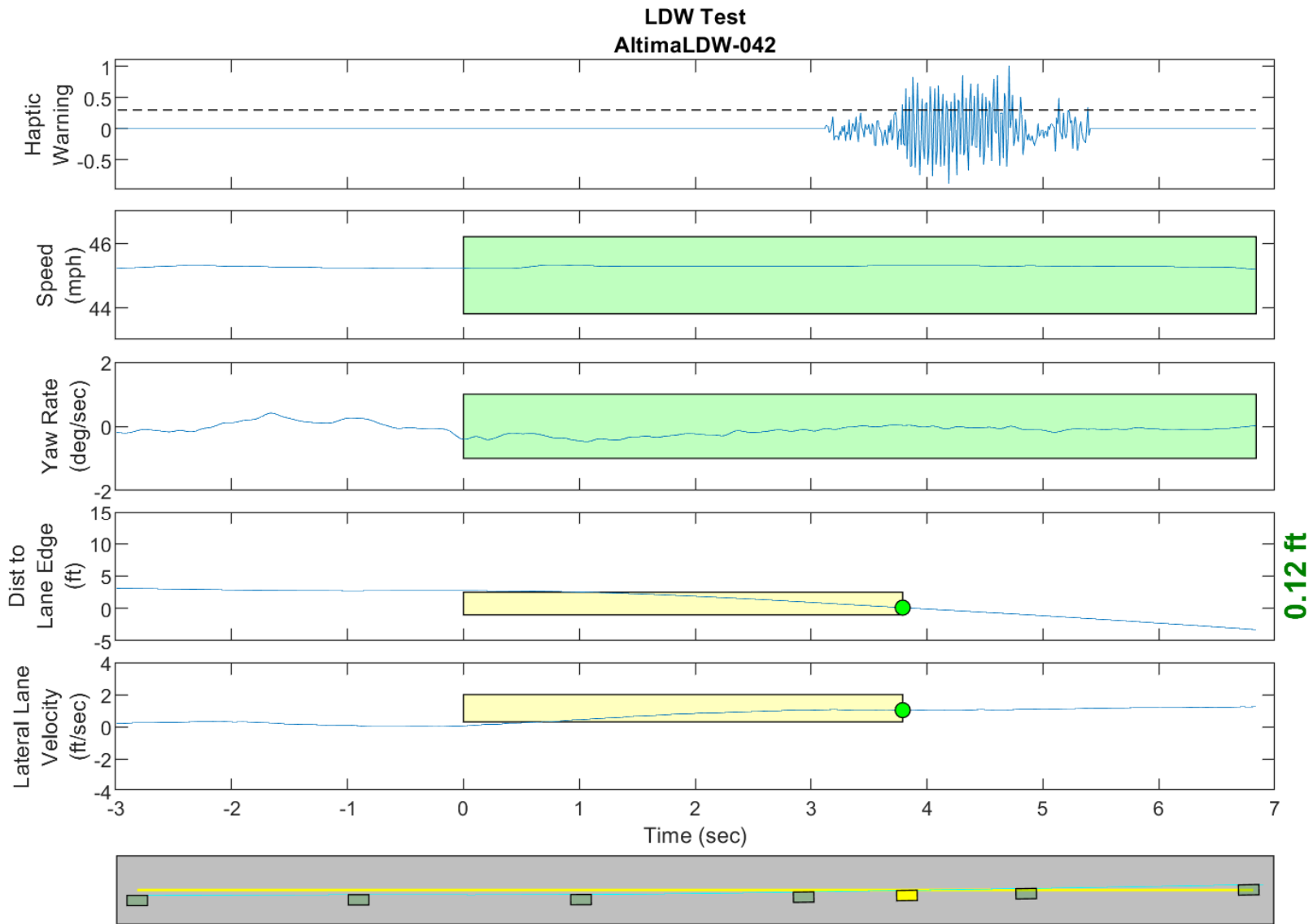

GPS Fix Type: RTK Fixed

Figure D82. Time History for Run 42, Dashed Line, Left Departure, Haptic Warning

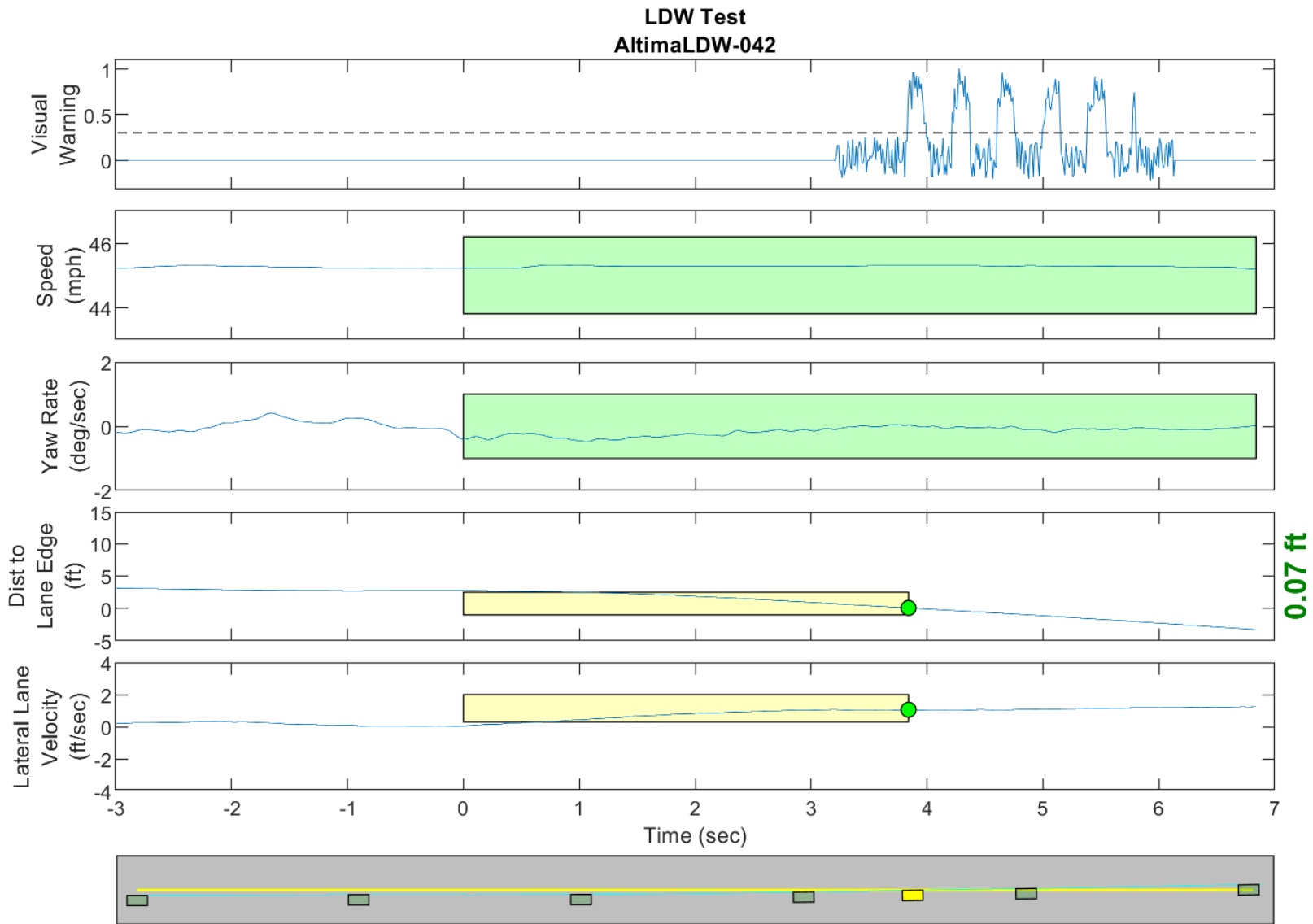

GPS Fix Type: RTK Fixed

Figure D83. Time History for Run 42, Dashed Line, Left Departure, Visual Warning

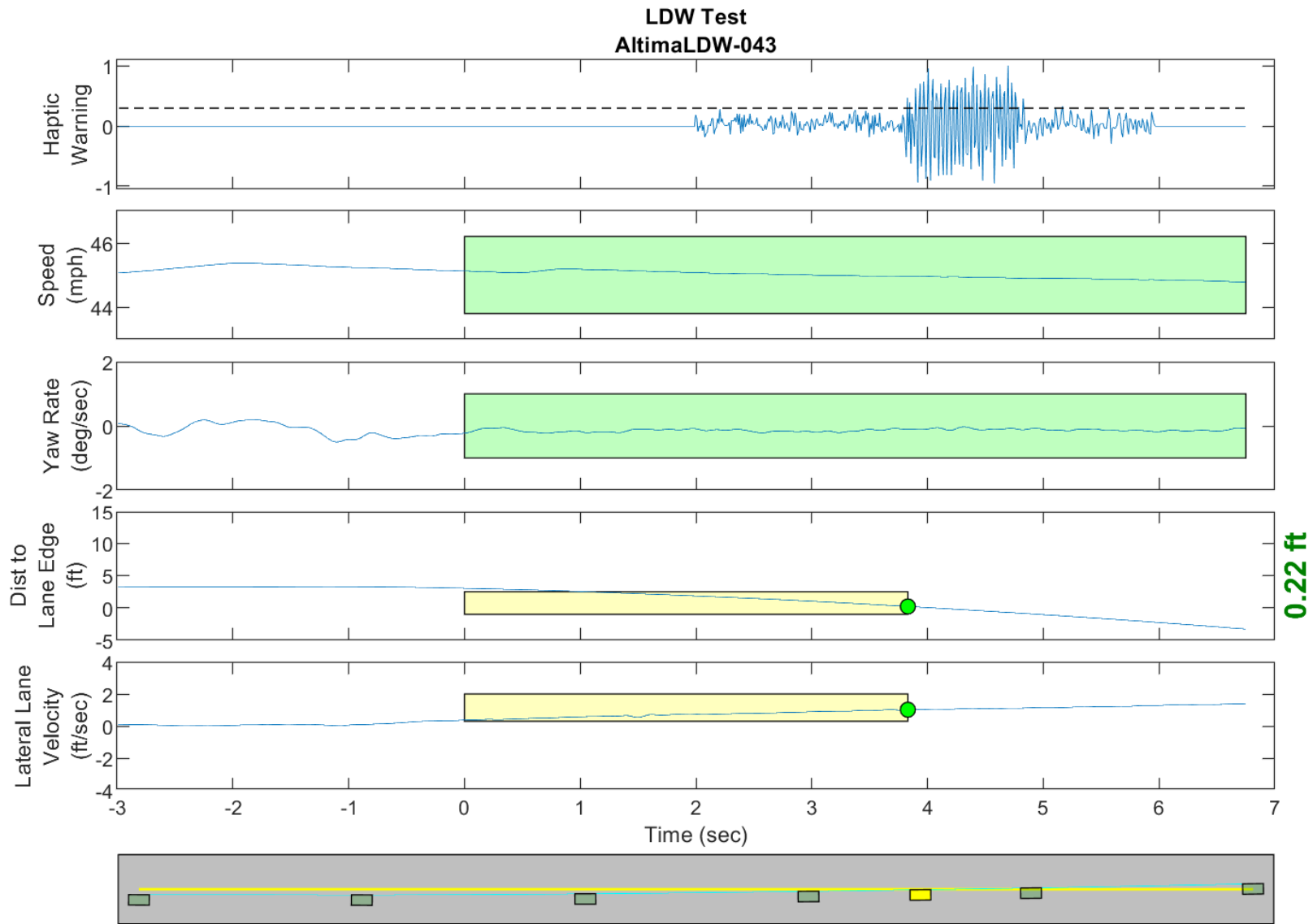

GPS Fix Type: RTK Fixed

Figure D84. Time History for Run 43, Dashed Line, Left Departure, Haptic Warning

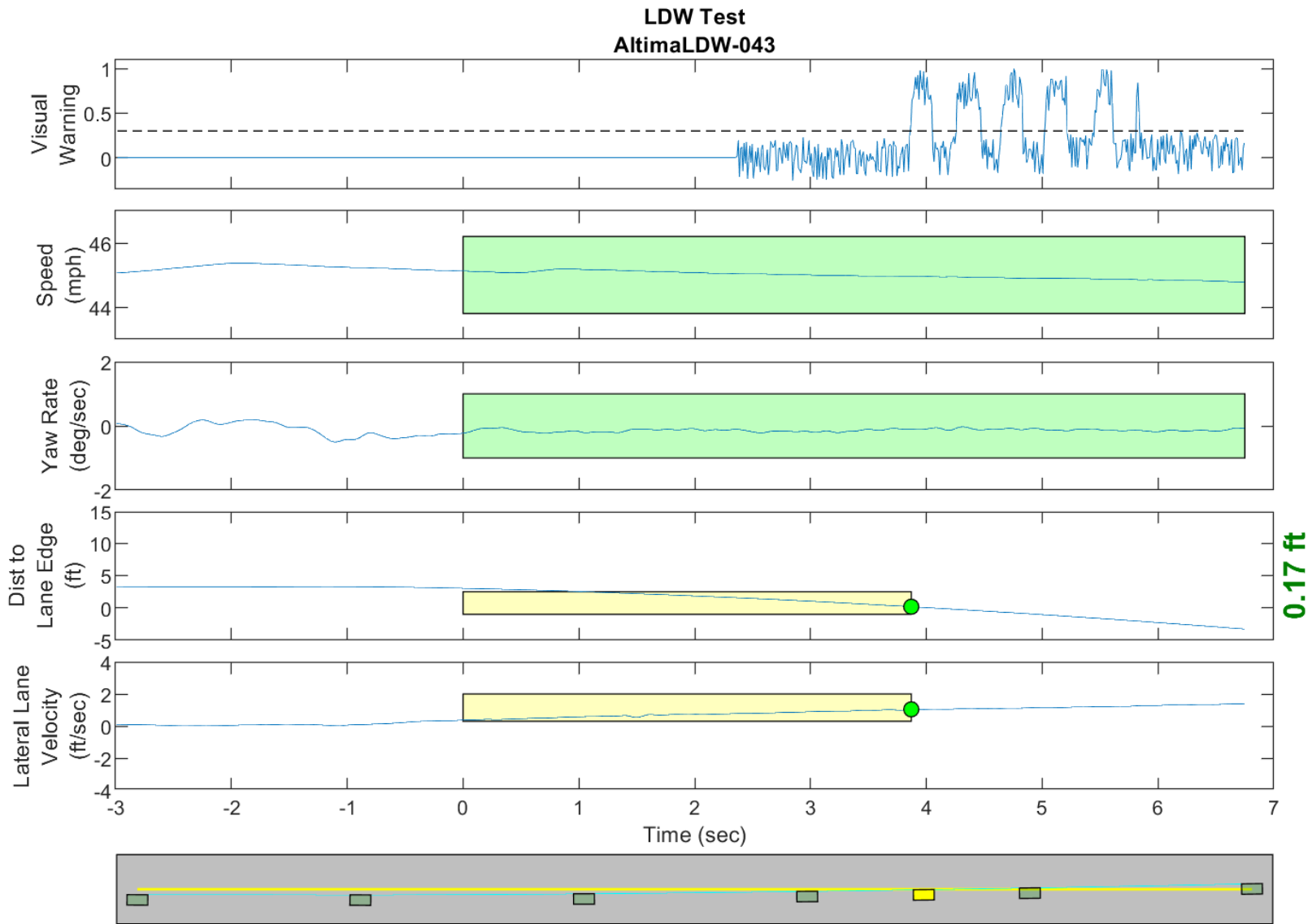

GPS Fix Type: RTK Fixed

Figure D85. Time History for Run 43, Dashed Line, Left Departure, Visual Warning