

**NEW CAR ASSESSMENT PROGRAM (NCAP)
DYNAMIC ROLLOVER RESISTANCE TEST**

Nissan Motor Co., LTD.
2018 Nissan Rogue FWD

TEST NUMBER: 18-24

Final Report
1 May 2018



Prepared by:

Dynamic Research, Inc
355 Van Ness Ave. #200
Torrance, CA 90501

Prepared for:

National Highway Traffic Safety Administration
Office of Crash Avoidance Standards
1200 New Jersey Avenue S.E.
Washington, DC 20590

The United States Government assumes no liability for the contents of this report or use thereof. If trade or manufacturers' names or products are mentioned, it is only because they are considered essential to the object of the publication and should not be construed as an endorsement. The United States Government does not endorse products or manufacturers.

Dynamic Research, Inc. does not endorse or certify products of manufacturers. The manufacturer's name appears solely to identify the test article. Dynamic Research, Inc. assumes no liability for the report or use thereof. It is responsible for the facts and the accuracy of the data presented herein. This report does not constitute a standard, specification, or regulation.

Report Prepared by:

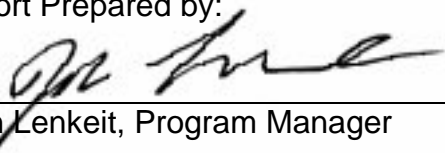

John Lenkeit, Program Manager

Date: 1 May 2018

Report Approved by:

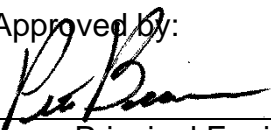

Peter Broen, Principal Engineer

Date: 1 May 2018

1. Report No. 18-24	2. Government Accession No.	3. Recipient's Catalog No.	
4. Title and Subtitle NCAP Dynamic Rollover Resistance Maneuver (Fishhook) Test of a 2018 Nissan Rogue FWD Crossover		5. Report Date 1 May 2018	6. Performing Organization Code DRI
		8. Performing Organization Report No. DRI- TM-18-52	
7. Author(s) John Lenkeit, Program Manager Peter Broen, Project Engineer		10. Work Unit No. (TRAIS)	
9. Performing Organization Name and Address Dynamic Research, Inc. 355 Van Ness Ave. #200 Torrance, CA 90501		11. Contract or Grant No. DTNH22-14-D-00332	
		13. Type of Report and Period Covered Final Report April 2018 to April 2018	
12. Sponsoring Agency Name and Address National Highway Traffic Safety Administration Office of Crash Avoidance Standards 1200 New Jersey Avenue S.E. Washington, DC 20590		14. Sponsoring Agency Code	
		15. Supplemental Notes	
16. Abstract An NCAP Dynamic Rollover Maneuver (Fishhook) Test was conducted on a 2018 Nissan Rogue FWD at Dynamic Research, Inc. on April 17, 2018. The vehicle did not experience two-wheel lift. The vehicle's steering angle at 0.3 g lateral acceleration at 50 mph was 34.1 degrees.			
17. Key Words NCAP Rollover Resistance Ratings Fishhook Test		18. Distribution Statement Copies of this report are available from: National Highway Traffic Safety Admin. Office of Crash Avoidance Standards 1200 New Jersey Ave., S.E. Washington, DC 20590	
19. Security Classif. (of this report) Unclassified	20. Security Classif. (of this page) Unclassified	21. Number of Pages 52	22. Price

TABLE OF CONTENTS

	Page
I. INTRODUCTION.....	1
II. VEHICLE PREPARATION	2
A. Test Vehicle	2
B. Tires	2
C. Vehicle Loading.....	2
D. Steering Controller	5
E. Instrumentation and Data Collection	5
F. Other Vehicle Preparation	5
III. TEST PROCEDURES.....	9
A. Test Procedure Overview.....	9
B. Test Conditions	10
IV. RESULTS.....	13
APPENDIX A Photographs	A-1
APPENDIX B Test Run Log.....	B-1
APPENDIX C Slowly Increasing Steer Test Worksheet.....	C-1
APPENDIX D Time History Plots	D-1

LIST OF FIGURES

	Page
1. Nominal Position of Video Cameras for Fishhook Tests	8
2. DRI-Minter Vehicle Dynamics Area	12

LIST OF TABLES

	Page
1. Test Vehicle Data	3
2. Tire Information	4
3. Vehicle Loading	4
4. Sensors	7
5. Surface Friction	10
6. Handwheel Angles	10
7. Weather Conditions	11

Section I INTRODUCTION

Beginning with the 2006 fiscal year, the National Highway Traffic Safety Administration (NHTSA) has engaged Dynamic Research, Inc. (DRI) of Torrance, CA to conduct dynamic rollover testing and gather data from that testing as part of NHTSA's New Car Assessment Program (NCAP).

The purpose of the testing reported herein was to determine if a typical 2018 Nissan Rogue FWD would experience tip-up, defined as simultaneous two-wheel lift of two inches or more at an entry speed of 50 mph or less in the Fishhook Procedure developed by NHTSA. This procedure may be found at www.regulations.gov, docket item NHTSA-2006-26555-0136.

The testing reported herein was accomplished under contract DTNH22-14-D-00332. The task order is entitled, "New Car Assessment Program (NCAP) Non-Destructive Vehicle Testing and Data Gathering."

Section II VEHICLE PREPARATION

A. TEST VEHICLE

The test vehicle was new or in as-new condition, meaning the vehicle had been driven no more than 500 miles prior to the start of dynamic rollover testing. It was acquired through a commercial rental/leasing company. Details of the test vehicle are given in Table 1.

B. TIRES

All tires used were new, and of the same make, model, size, and DOT specification of those installed on the vehicle when purchased new. Tire inflation pressures were in accordance with the recommendations indicated on each vehicle's identification placard. To reduce the possibility of tire debanding during Fishhook testing, an appropriately sized inner tube was installed in each tire. To further reduce the possibility of tire debanding, the tires were mounted to the rims without the use of tire mounting lubricant. Tire specifications are listed in Table 2.

C. VEHICLE LOADING

The multi-passenger load, described in the Fishhook Procedure, was used for all tests. The load and positioning of the load in the vehicle are listed in Table 3.

In addition to water dummies, the loading included instrumentation, a steering machine, and outriggers. Test vehicle bumper assemblies were removed for outrigger installation. The reduction in vehicle weight due to the removal of the bumpers was offset by the additional weight of the outriggers and their mounting system. The outrigger system typically outweighs the bumper assemblies.

Table 1. Test Vehicle Data

General Data					
Model year, make, model	2018 Nissan Rogue FWD				
VIN	JN1BJ1CP2JW10xxxx				
Body style	Crossover				
Number of doors	4				
Trim level	Sport S				
Seating positions	Front:	2 nd row	3 rd row	4 th row	5 th row
	2	3			
Electronic stability control	Yes				
4-Wheel ABS (Yes/No)	Yes				
Power steering (Yes/No)	Yes				
Major optional equipment					
Odometer at start of testing	5 miles				
Drivetrain					
Engine cylinder arrangement	Inline 4				
Engine displacement	2 L				
Transmission type	CVT				
Drive arrangement	FWD				
Chassis					
Track width	F: 62.4 in (1585 mm) , R: 62.2 in (1579.9 mm)				
Wheelbase	104.2 in (2646.7 mm)				
Curb weight	3211 lb (1456.5 kg)				
Certification Data from Vehicle's Label					
Vehicle manufactured by	Nissan Motor Co., LTD.				
Date of manufacture	11/17				
GVWR	4340 lb (1969 kg)				
GAWR Front	2325 lb (1055 kg)				
GAWR Rear	2050 lb (930 kg)				

Table 2. Tire Information

Tire Manufacturer	Yokohama
Tire Model	Geolandar G055
Tire Size	Front: 215/65R16 Rear: 215/65R16
Load rating	Front: 98 Rear: 98
Speed rating	Front: H Rear: H
Treadwear grade	Front: 280 Rear: 280
Traction grade	Front: B Rear: B
Temperature grade	Front: A Rear: A
Location of "Recommended Tire Pressure" label	Driver's door jamb
Recommended cold tire pressure	Front: 33 psi, (230 kPa) Rear: 33 psi, (230 kPa)
First 8 digits of DOT code	Front: FDHB PMC Rear: FDHB PMC

Table 3. Vehicle Loading

Water dummy and other loading	3 water dummies in second row
Water dummy weight	175 lb (79.4 kg)
Fuel level	Full
Weight as Tested	
Left front	1188 lb (538.9 kg)
Right front	1072 lb (486.3 kg)
Left rear	966 lb (438.2 kg)
Right rear	939 lb (425.9 kg)

D. STEERING CONTROLLER

Precise controlled steering is accomplished using a steering machine designed and constructed by DRI. DRI has used its Automated Vehicle Controller (AVC) steering machine for many vehicle tests including FMVSS 126 tests. It can provide up to 65 ft-lb torque and rates over 1300 deg/sec. The integrated angle encoder has an unlimited range with a resolution of 0.045 degrees and an accuracy of ± 0.045 degrees. The steering motor is controlled by a MicroAutoBox II from dSPACE which also acts as the data acquisition system.

E. REAL-TIME CONTROLLER AND DATA ACQUISITION

Data acquisition is achieved using a MicroAutoBox II from dSPACE which also serves as the real-time system for the steering controller. Data from the Oxford IMU, including Longitudinal, Lateral, and Vertical Acceleration, Roll, Yaw, and Pitch Rate, Forward and Lateral Velocity, Roll and Pitch Angle are sent over Ethernet to the Micro AutoBox. The Oxford IMUs are calibrated per the manufacturer's recommended schedule (Table 4). The MicroAutoBox II specifications are:

Model: D-Space Micro-Autobox II 1401/1513
Base Board SN 549068
I/O Board SN 588523

A list of the sensors is given in Table 4.

Two video cameras were used to record the Fishhook runs. They were positioned nominally as shown in Figure 1. The recorded videotapes were reviewed after the Fishhook runs to check for any two wheel lift. If any two wheel lift was observed, eight infrared distance measuring sensors for measurement of wheel lift (two sensors at each wheel) were then mounted for use in subsequent confirmation Fishhook tests.

F. OTHER VEHICLE PREPARATION

In addition to installation and preparation discussed above, the test vehicle was prepared as follows:

- Front and rear bumpers were removed
- Outrigger mounts were installed in the bumper locations and titanium outriggers were fastened to these mounts

- A five point safety harness was installed.
- Airbags were removed or otherwise disabled

Photographs of the vehicle tested are given in Appendix A.

Table 4. Sensors

Measured Variable	Sensor	Range	Resolution	Accuracy	Specifics	Serial Number	Calibration
Vehicle Tire Pressure	Tire Pressure Gauge	0-100 psi 0-690 kPa	0.01 psi 6.89 kPa	< 1% error between 20 and 100 psi	Omega DPG8001	17042707002	By: DRI Date: 6/8/2017 Due: 6/8/2018
Vehicle Total, Wheel, and Axle Load	Platform Scales (Minter)	7000 lb 31.1 kN 31.1 kN	0.5 lb 2.2 N 2.2 N	±0.1% of applied load	Proform 67644	VS800W16- 00455	By: DRI Date: 6/1/2017 Due: 6/1/2018
	Platform Scales (Torrance)	1500 lb/platform 6672 N/platform	1 lb 4.4 N	0.5% of applied load	Intercomp SW I	24032361	By: DRI Date: 12/12/2017 Due: 12/12/2018
Handwheel Angle	Steering Angle Encoder (Automated Steering Controller)	±800 deg	0.25 deg	±0.25 deg	DRI Automatic Vehicle Controller using D-Space Micro- Autobox II	NA	Verified by DRI at installation ¹
Longitudinal, Lateral, and Vertical Acceleration Roll, Yaw, and Pitch Rate, Forward and Lateral Velocity, Roll and Pitch Angle	Multi-Axis Inertial Sensing System	Accels ± 5 g, Angular Rate ±300 deg/s, Angle >45 deg, Velocity >200 km/h	Accels .001 g, Angular Rate 0.01 deg/s, Angle 0.05 deg, Velocity 0.1 km/h	Accels .001g, Angular Rate 0.01 deg/s, Angle 0.05 deg, Velocity 0.1 km/h	Oxford xNav 550	015386	By: Oxford Technical Solutions Date: 6/21/2017 Due: 6/21/2019

1 . The steering encoder is checked prior to beginning tests to verify that there are no faults. The steering controller is installed in the vehicle and the steering wheel is turned through two complete revolutions while recording data. The data are then reviewed for any dropouts or other nonlinearities that would indicate dust intrusion or faulty sectors.

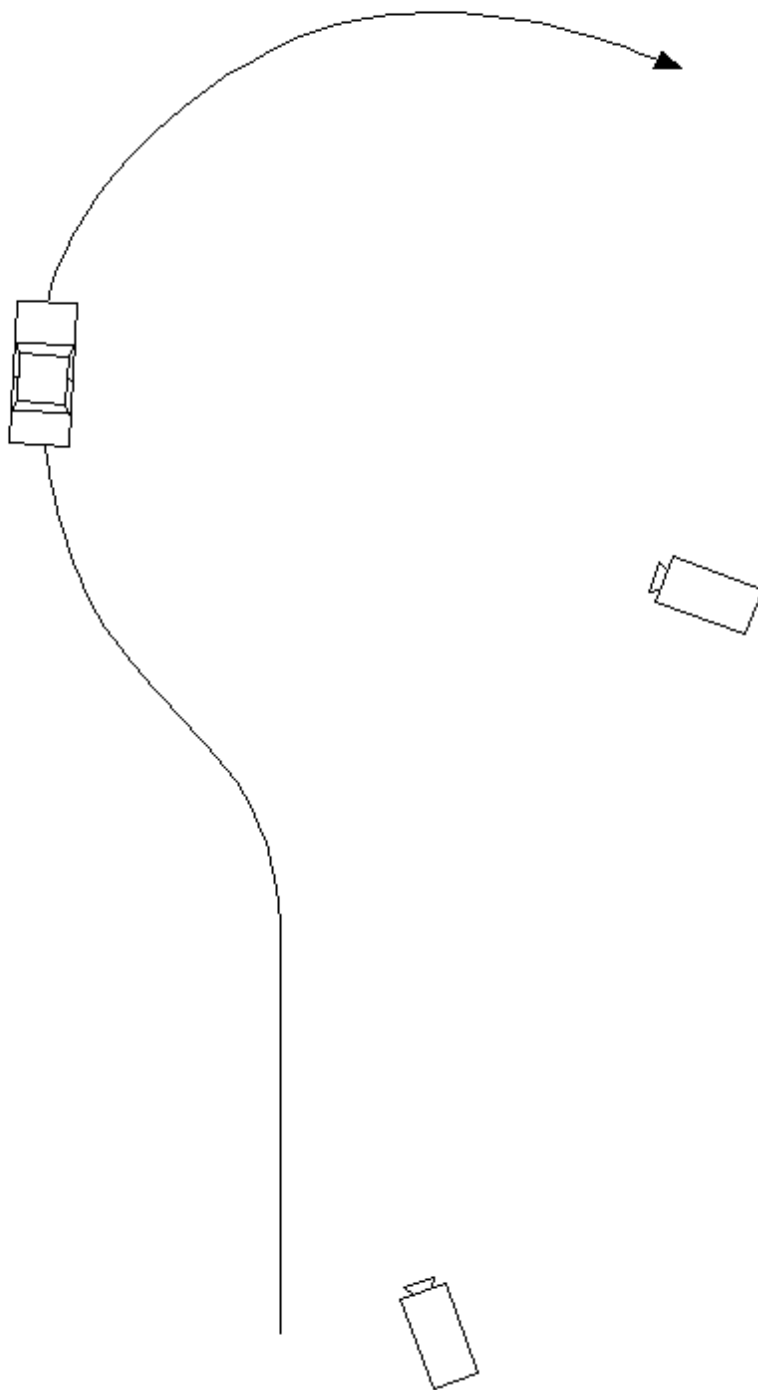

Figure 1. Nominal Position of Video Cameras for Fishhook Tests

Section III TEST PROCEDURES

This section includes a general overview of the test procedures and details of the particular test.

A. TEST PROCEDURE OVERVIEW

This test was conducted in accordance with NHTSA's NCAP Rollover Resistance Test Procedure (Fishhook) as described in the Federal Register (68 FR 59250). Detailed descriptions of the test procedure, pass/fail criteria, and data acquisition specifications may be found at docket NHTSA-2001-9663.

There are two major components of the test procedure, the Slowly Increasing Steer (SIS) pre-test and the Fishhook test.

The Slowly Increasing Steer (SIS) maneuver was used to characterize the steady state lateral dynamics of each vehicle, and is based on the "Constant Speed, Variable Steer" test defined in SAE J266. The maneuver is used to determine the handwheel angle that produces a lateral acceleration of 0.3 g at 50 mph. This handwheel angle is then used to determine the magnitude of steering to be used for the NHTSA Fishhook maneuver.

SIS tests were performed at a constant speed of 50 mph. Handwheel angle was input at a rate of 13.5 deg/sec, from 0 to an angle that provided at least 0.55 g. Three tests were conducted in each direction, and the data for the six runs were averaged to obtain the handwheel angle that produced 0.3 g at 50 mph.

The Fishhook test is a programmed steering maneuver that is implemented via the steering controller. The vehicle was initially steered in one direction and then the steering was reversed. The timing, magnitude and rate of the steering were prescribed by the Fishhook Procedure.

To begin the maneuver, the vehicle was driven in a straight line at a speed slightly greater than the desired entrance speed. The driver then released the throttle. When the vehicle was at the target speed, the steering controller automatically initiated the steering maneuver. Following completion of the steering reversal the handwheel position was maintained for three seconds, and then returned to zero angle in 1 second.

The tests were conducted in both left-right and right-left directions. The “Default” test series used a handwheel angle equal to 6.5 times the handwheel angle that produced 0.3 g at 50 mph in the SIS tests, and initial vehicle speeds beginning at 35 mph and concluding up to 50 mph (if no two-wheel lift occurs). Supplemental tests were also done, as specified in the Fishhook Procedure.

B. TEST CONDITIONS

1. Test Surface

The tests were conducted on the Vehicle Dynamics Area at DRI’s Minter Field facility, located near Bakersfield, California, on 4/17/2018. The VDA has a smooth, flat (slope less than 0.5% throughout) asphaltic concrete surface. Its dimensions are as shown in Figure 2. It was built in the spring of 2005.

VDA surface friction measurements were accomplished using the DRI Mobile Tire Tester. Three runs were done, one at each of three previously determined locations. Each run provided for a minimum of 3 seconds of tire friction at constant normal load, slip angle, and speed in a free rolling condition. The test was accomplished using an ASTM E1136 tire with an inflation pressure of 35 (± 0.5) psi at a test speed of 40 (± 0.5) mph. The net slip angle of the test tire for each test run was 7.5 deg. The test tire was no older than 6 months from the date of manufacture. The surface friction measurement results are shown in Table 5.

Table 5. Surface Friction

Date of surface friction measurements	4/17/2018
Average normalized lateral force	0.814

2. Fishhook Handwheel Angles

The 0.3 g handwheel angle obtained from the SIS tests and the handwheel angles used in the Fishhook tests are shown in Table 6.

Table 6. Handwheel Angles

0.3 g handwheel angle (from SIS tests at 50 mph)	34.1 °
5.5 scalar handwheel angle for Fishhook Test	188°
6.5 scalar handwheel angle for Fishhook Test	222 °

3. Weather Conditions

The weather conditions, recorded at the end of testing, are shown in Table 7.

Table 7. Weather Conditions

Ambient temperature	57 °F (13.9 °C)
Wind Speed	3 mph (1.3 m/s)
Wind Direction	S

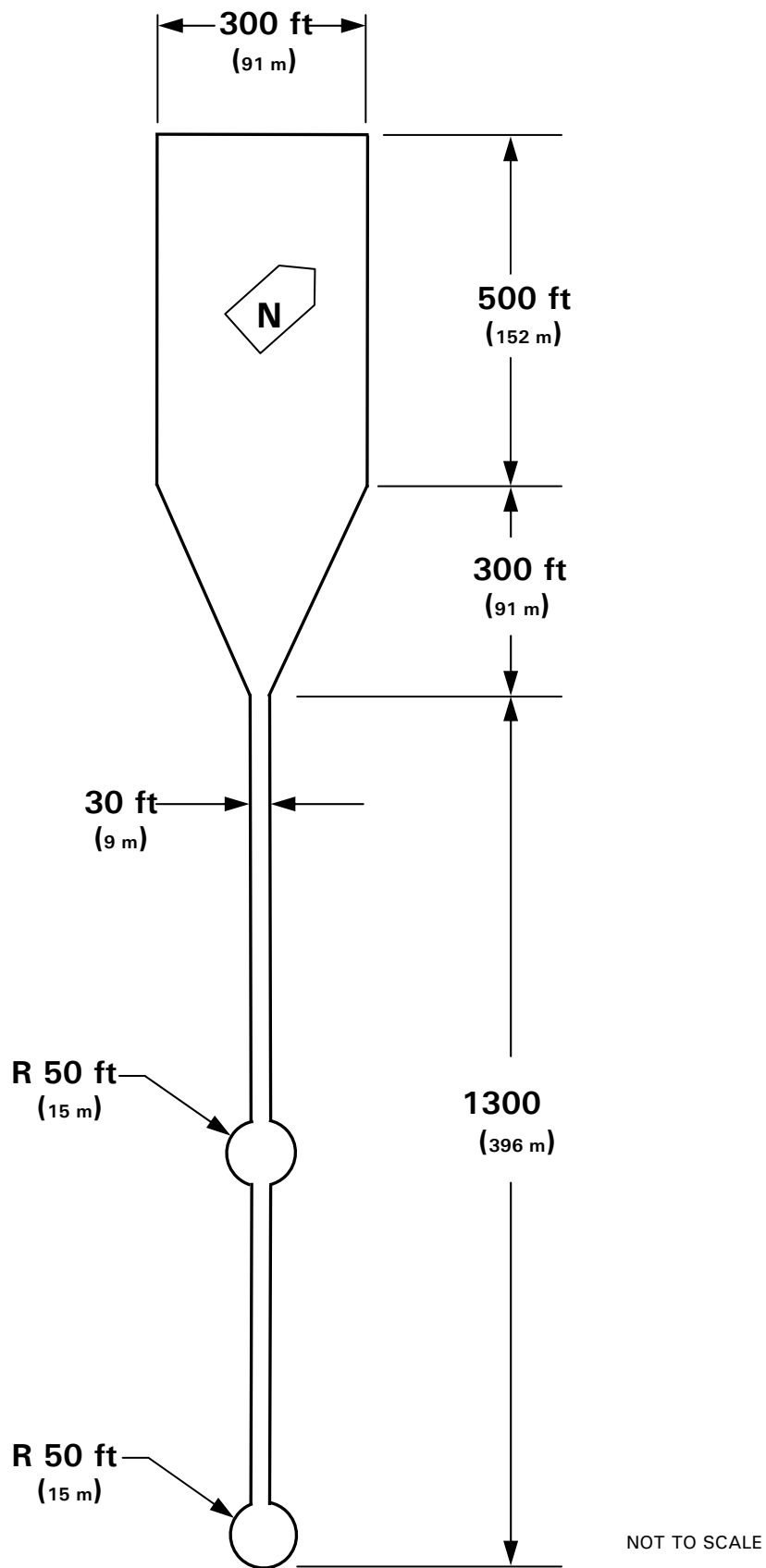

Figure 2. DRI-Minter Vehicle Dynamics Area

Section IV

RESULTS

The test run log is given in Appendix B. The Slowly Increasing Steer Test Worksheet is given in Appendix C. Appendix D contains time history plots for the 50 mph runs and any runs which resulted in two-wheel lift. For the 2018 Nissan Rogue FWD, there was no two-wheel lift at any test condition.

APPENDIX A

Photographs

LIST OF FIGURES

	Page
A1. Window Sticker.....	A-3
A2. Front View, Test Vehicle as Delivered	A-4
A3. Rear View, Test Vehicle as Delivered	A-5
A4. Front View, Test Vehicle in Test Condition.....	A-6
A5. Rear View, Test Vehicle in Test Condition	A-7
A6. Instrumentation in Test Vehicle	A-8
A7. Steering Controller and Computer	A-9
A8. Ballast Condition.....	A-10



2018 NISSAN ROGUE SPORT S FWD



Scan QR code for general model information & options

<p>Standard Equipment Included at No Extra Charge</p> <p>MECHANICAL & PERFORMANCE 2.0L DOHC 16-Valve 4-Cylinder Engine 141 Horsepower and 147 lb-ft of Torque Eco Mode Front Independent Suspension Rear Multilink Suspension 16" Steel Wheels w/ Full Wheel Covers 215/65R16 all-season tires Temporary spare tire</p> <p>SAFETY & SECURITY Driver & Front Passenger Side-impact, Curtain Air Bags Lower Anchors and Tethers for Children (LATCH) 4-wheel power-assisted disc brakes with ABS Vehicle Dynamic Control (VDC) Electronic Brake force Distribution (EBD) Brake Assist (BA) Vehicle Security System Tire Pressure Monitoring System (TPMS) with Easy-Fill Tire Alert</p> <p>COMFORT & CONVENIENCE 60/40 split fold-down rear seat 2nd Row Seat A/C Vents Hill Start Assist Cruise Control with steering-wheel-mounted-controls Tilt and telescope steering column Power Door Locks w/ Auto-Locking Feature Power Windows w/Driver Auto-up/down RearView Monitor AM/FM/CD/Aux audio system with 5" color monitor and 4 speakers USB connection port for iPod® interface and other compatible devices Bluetooth® Hands-free Phone System Streaming audio via Bluetooth® Hands-free text messaging assistant* SiriusXM Satellite Radio** Siri® Eyes Free® 12-volt DC power outlet Cargo cover</p>	<p>EXTERIOR LED Daytime Running Lights Auto Off Halogen Headlights w/ LED signature</p>	<p>Manufacturer's Suggested Retail Base Price: \$21,640.00</p> <p>Options Included by Manufacturer Splash Guards 160.00 Chrome Rear Bumper Protector 160.00 Carpeted Cargo Area Protector, Floor Mats, First Aid Kit 275.00</p> <p>DESTINATION CHARGES 975.00</p> <hr/> <p>Total* \$23,210.00</p>
--	--	--

EPA DOT Fuel Economy and Environment

Fuel Economy

28 MPG
combined city/hwy

25 32
city highway

3.6 gallons per 100 miles

You save \$250
 in fuel costs over 5 years compared to the average new vehicle.

Annual fuel cost \$1,300

Fuel Economy & Greenhouse Gas Rating (stripes only) **Smog Rating** (stripes only)

1 **6** 10 1 **5** 10
Best Best

This vehicle emits 318 grams CO₂ per mile. The best emits 6 grams per mile (stripes only). Producing and distributing fuel also create emissions. Learn more at fuelconomy.gov.

Actual results will vary for many reasons, including driving conditions and how you drive and maintain your vehicle. The average new vehicle gets 27 MPG and costs \$6,750 to fuel over 5 years. Cost estimates are based on 15,000 miles per year at \$2.40 per gallon. MPGe is miles per gasoline gallon equivalent. Vehicle emissions are a significant cause of climate change and smog.

fuelconomy.gov
 Calculate personalized estimates and compare vehicles

GOVERNMENT 5-STAR SAFETY RATINGS

Overall Vehicle Score **Not Rated**
 Based on the combined ratings of frontal, side and rollover. Should ONLY be compared to other vehicles of similar size and weight.

Frontal Crash	Driver Passenger	Not Rated Not Rated
<small>Based on the risk of injury in a frontal impact. Should ONLY be compared to other vehicles of similar size and weight.</small>		
Side Crash	Front seat Rear seat	Not Rated Not Rated
<small>Based on the risk of injury in a side impact.</small>		
Rollover		Not Rated
<small>Based on the risk of rollover in a single-vehicle crash.</small>		

Star ratings range from 1 to 5 stars (*****), with 5 being the highest.
 Source: National Highway Traffic Safety Administration (NHTSA)
www.safercar.gov or 1-888-327-4236

DELIVERY

VEHICLE COLORS:
 EXT: BRILLIANT SILVE
 INT: CHARCOAL

FINAL ASSEMBLY POINT:
 LOS ANGELES

TRANSPORT METHOD:
 TRUCK

DEALER:

This Vehicle qualifies for Nissan's

Security+Plus Extended Protection Plan

The only service agreement backed by Nissan Extended Services North America! Ask your dealer for details, or call 1-800-NISSAN-1 for more information

VIN: JN1BJ1CP2JW10
 EMS: 50 STATE EMISSIONS
 MDL: 27118-106424 K23-G
 OPT: H-B92B93L92C03266

20180202225347AS5630

*Does not include dealer installed options and accessories, local taxes or license fees. This label has been applied pursuant to federal law. Do not remove prior to delivery to the ultimate purchaser.

Figure A1. Window Sticker



Figure A2. Front View, Test Vehicle as Delivered



Figure A3. Rear View, Test Vehicle as Delivered



Figure A4. Front View, Test Vehicle in Test Condition



Figure A5. Rear View, Test Vehicle in Test Condition



Figure A6. Instrumentation in Test Vehicle



Figure A7. Steering Controller and Computer



Figure A8. Ballast Condition

APPENDIX B

Test Run Log

Vehicle: **2018 Nissan Rogue FWD**Driver: **John Partridge**Date: **4/17/2018**

Run Number	Test Type	Speed (mph)	Handwheel Angle (deg)	Dir. of First Steer	2 Wheel Lift	Notes
1	Tire Warm-Up	35	40	Right	NA	Resulted in ay = 0.29g
2			80			Resulted in ay = 0.55g
3						
4						
5						2x SWA last cycle
6	Static	0	0			
7	Steady State	50	0			
8	Slowly Increasing Steer	50	50	Left	NA	Resulted in ay = 52g
9				Left		
10				Left		
11				Right		
12				Right		
13				Right		
14	Tire Warm-Up	35	80	Right	NA	Resulted in ay = 0.55g
15						
16						
17						2X SWA
18	6.5 Fishhook	35	222	Left	No	
19		40			No	
20		45			No	
21		47.5			No	
22		50			No	

Vehicle: **2018 Nissan Rogue FWD**Driver: **John Partridge**Date: **4/17/2018**

Run Number	Test Type	Speed (mph)	Handwheel Angle (deg)	Dir. of First Steer	2 Wheel Lift	Notes
23	5.5 Fishhook	45	188	Left	No	
24		47.5			No	
25		50			No	
26	6.5 Fishhook	35	222	Right	No	
27		40			No	
28		45			No	
29		47.5			No	
30		50			No	
31	5.5 Fishhook	45	188	Right	No	
32		47.5			No	
33		50			No	

APPENDIX C

Slowly Increasing Steer Test Worksheet

NCAP, 2018 Nissan Rogue FWD , Multi-Passenger Load, Test Date: 4/17/2018

SIS_out_v2

Run	Dir of Steer	Start Speed (mph)	End Speed (mph)	Speed Red. (%)	Index of ay @ 0.3g	HW Angle (deg) at 0.3g	ay (g) @ 0.3g index	6.5x HW Angle (deg)	Ramp Time (sec) at 6.5x	5.5x HW Angle (deg)	Ramp Time (sec) at 5.5x	R2	Zero Begin Index	Zero End Index
8	Left	50.2	0.0	100	1302	-33.4	-0.306	-217.1	-0.3015	-183.7	-0.2551	0.9948	600	800
9	Left	50	0.0	100	1298	-33.2	-0.297	-215.9	-0.2998	-182.7	-0.2537	0.9959	601	800
10	Left	50	0.0	100	1301	-33.3	-0.297	-216.6	-0.3009	-183.3	-0.2546	0.9951	601	800
11	Right	50.3	0.0	100	1312	34.2	0.305	222.1	0.3085	187.9	0.2610	0.9965	600	800
12	Right	50.2	0.0	100	1332	35.5	0.299	230.7	0.3204	195.2	0.2711	0.9967	600	800
13	Right	50.2	0.0	100	1324	35.0	0.306	227.2	0.3156	192.3	0.2671	0.9973	600	800

Mean: 34.1 0.302 222 0.308 188 0.26

Steering Controller Input Values

Scalar 6.5 values:

Initial HW angle: 222 deg
Initial time: 0.308 s
Reversal HW angle: -222 deg
Reversal time: 0.616 s

Scalar 5.5 values:

Initial HW angle: 188 deg
Initial time: 0.26 s
Reversal HW angle: -188 deg
Reversal time: 222 s

APPENDIX D

Time History Plots

LIST OF FIGURES

	Page
D1. Vehicle Speed, Handwheel Angle, and Roll Angle Time History Plots for Default Test Series, L-R, 50 mph	D-3
D2. Steering Machine Operation Time History Plots for Default Test Series, L-R, 50 mph.....	D-4
D3. Yaw Rate, Roll Rate, and Lateral Acceleration Time History Plots for Default Test Series, L-R, 50 mph	D-5
D4. Pitch Rate and Longitudinal Acceleration Time History Plots for Default Test Series, L-R, 50 mph	D-6
D5. Vehicle Speed, Handwheel Angle, and Roll Angle Time History Plots for Default Test Series, R-L, 50 mph	D-7
D6. Steering Machine Operation Time History Plots for Default Test Series, R-L, 50 mph	D-8
D7. Yaw Rate, Roll Rate, and Lateral Acceleration Time History Plots for Default Test Series, R-L, 50 mph	D-9
D8. Pitch Rate and Longitudinal Acceleration Time History Plots for Default Test Series, R-L, 50 mph	D-10
D9. Vehicle Speed, Handwheel Angle, and Roll Angle Time History Plots for Supplemental 2 Test Series, L-R, 50 mph.....	D-11
D10. Steering Machine Operation Time History Plots for Supplemental 2 Test Series, L-R, 50 mph	D-12
D11. Yaw Rate, Roll Rate, and Lateral Acceleration Time History Plots for Supplemental 2 Test Series, L-R, 50 mph	D-13
D12. Pitch Rate and Longitudinal Acceleration Time History Plots for Supplemental 2 Test Series, L-R, 50 mph	D-14
D13. Vehicle Speed, Handwheel Angle, and Roll Angle Time History Plots for Supplemental 2 Test Series, R-L, 50 mph.....	D-15
D14. Steering Machine Operation Time History Plots for Supplemental 2 Test Series, R-L, 50 mph	D-16
D15. Yaw Rate, Roll Rate, and Lateral Acceleration Time History Plots for Supplemental 2 Test Series, R-L, 50 mph	D-17
D16. Pitch Rate and Longitudinal Acceleration Time History Plots for Supplemental 2 Test Series, R-L, 50 mph	D-18

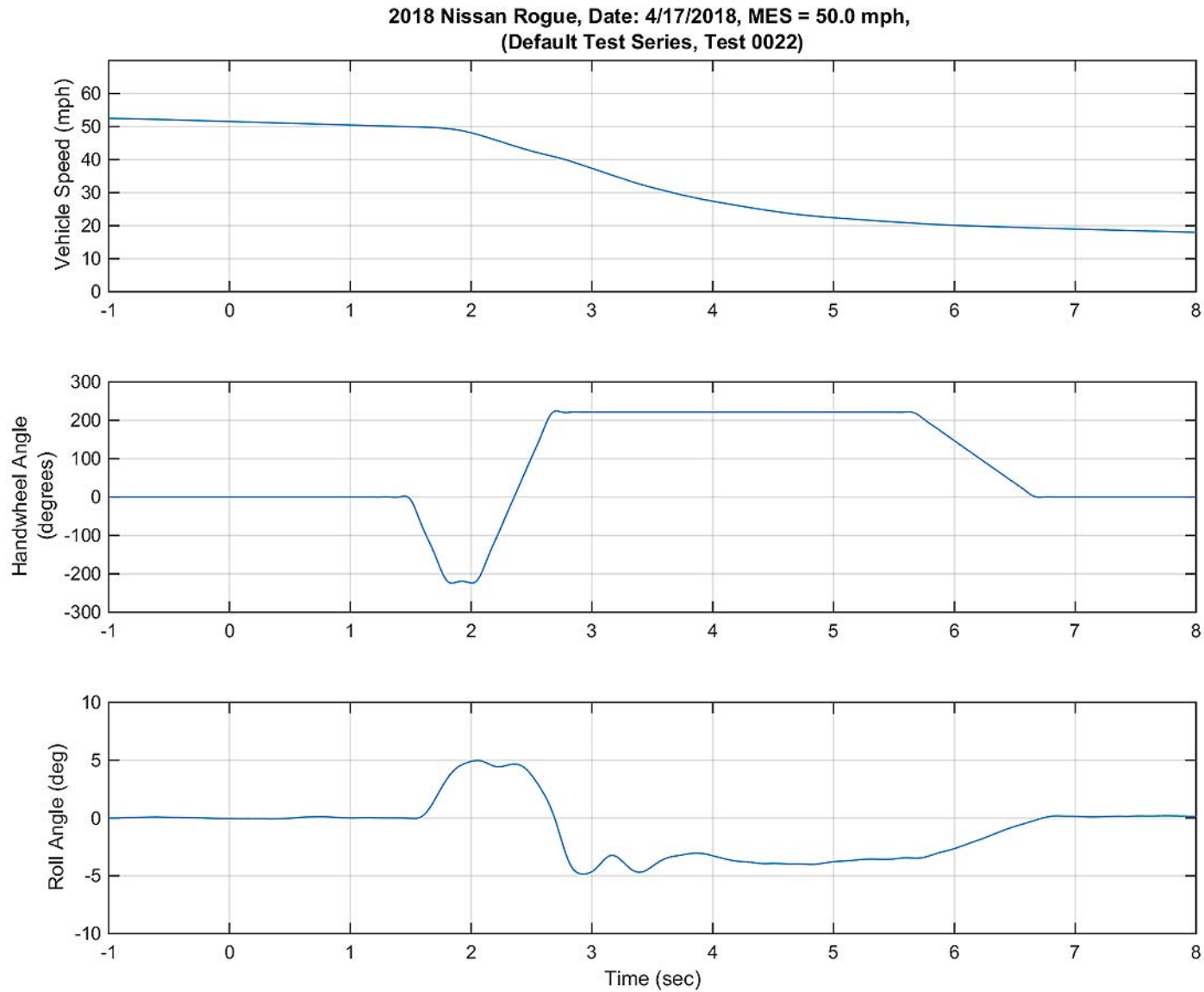

Figure D1. Vehicle Speed, Handwheel Angle, and Roll Angle Time History Plots for Default Test Series, L-R, 50 mph

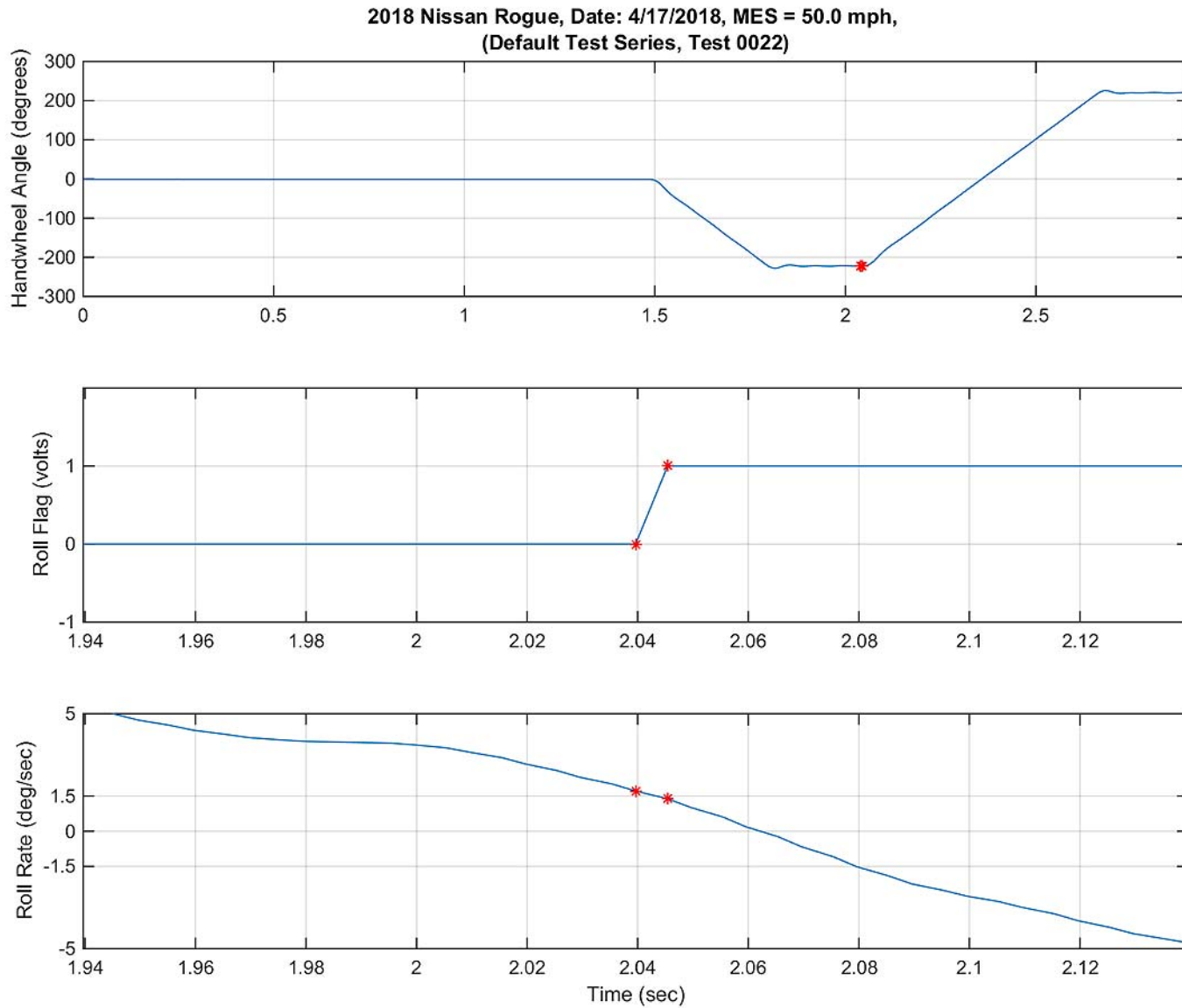

Figure D2. Steering Machine Operation Time History Plots for Default Test Series, L-R, 50 mph

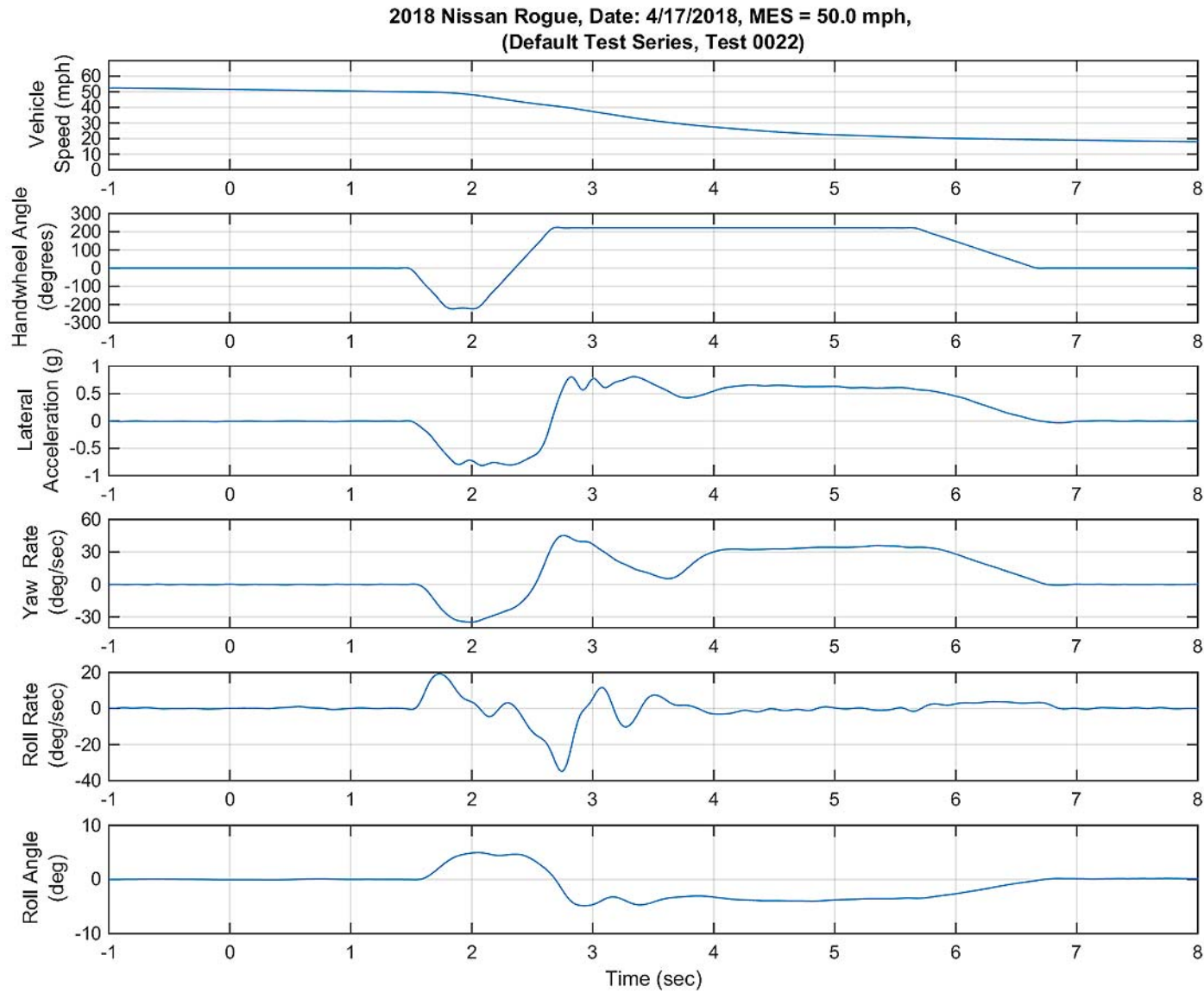

Figure D3. Yaw Rate, Roll Rate, and Lateral Acceleration Time History Plots For Default Test Series, L-R, 50 mph

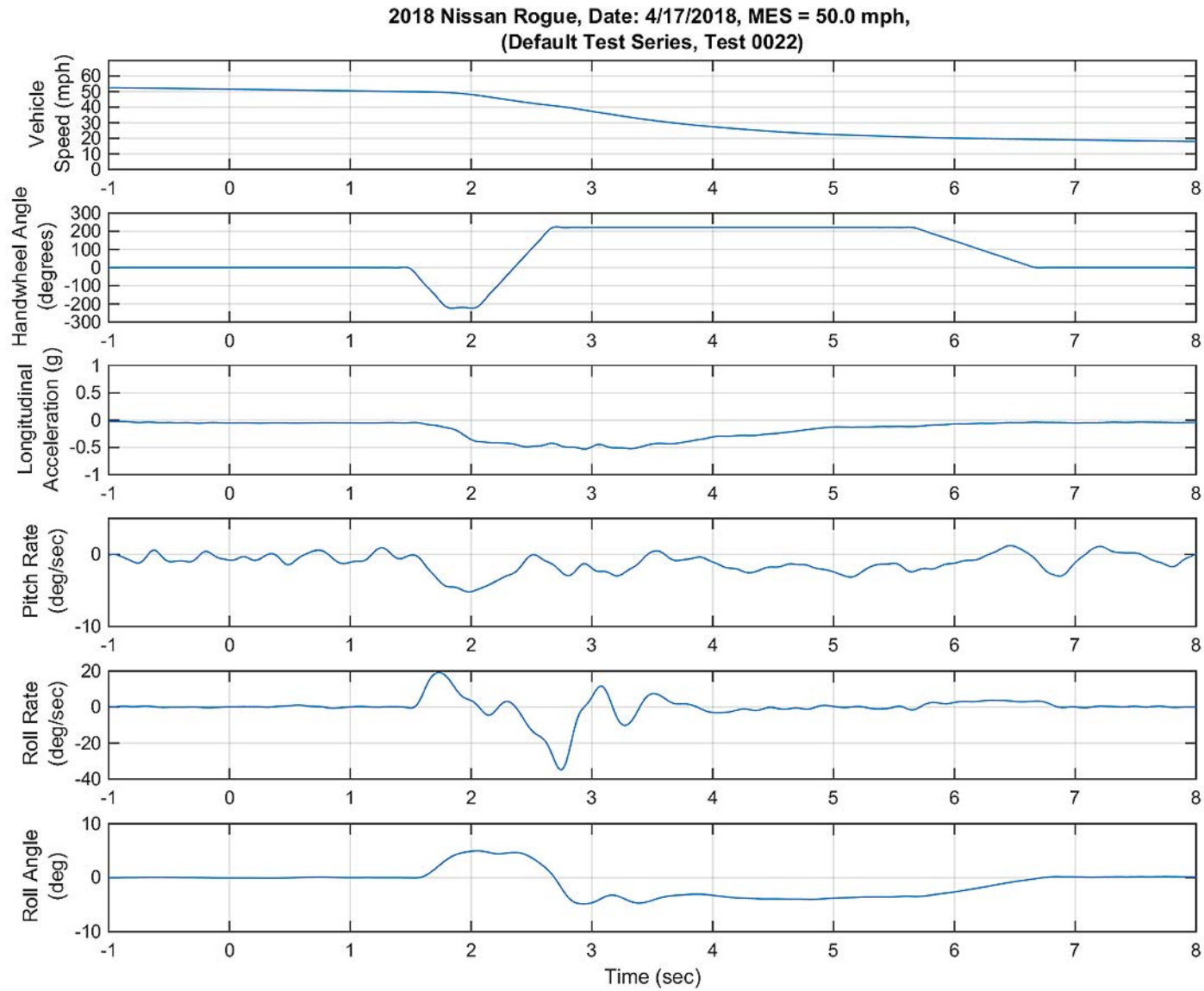

Figure D4. Pitch Rate and Longitudinal Acceleration Time History Plots for Default Test Series, L-R, 50 mph

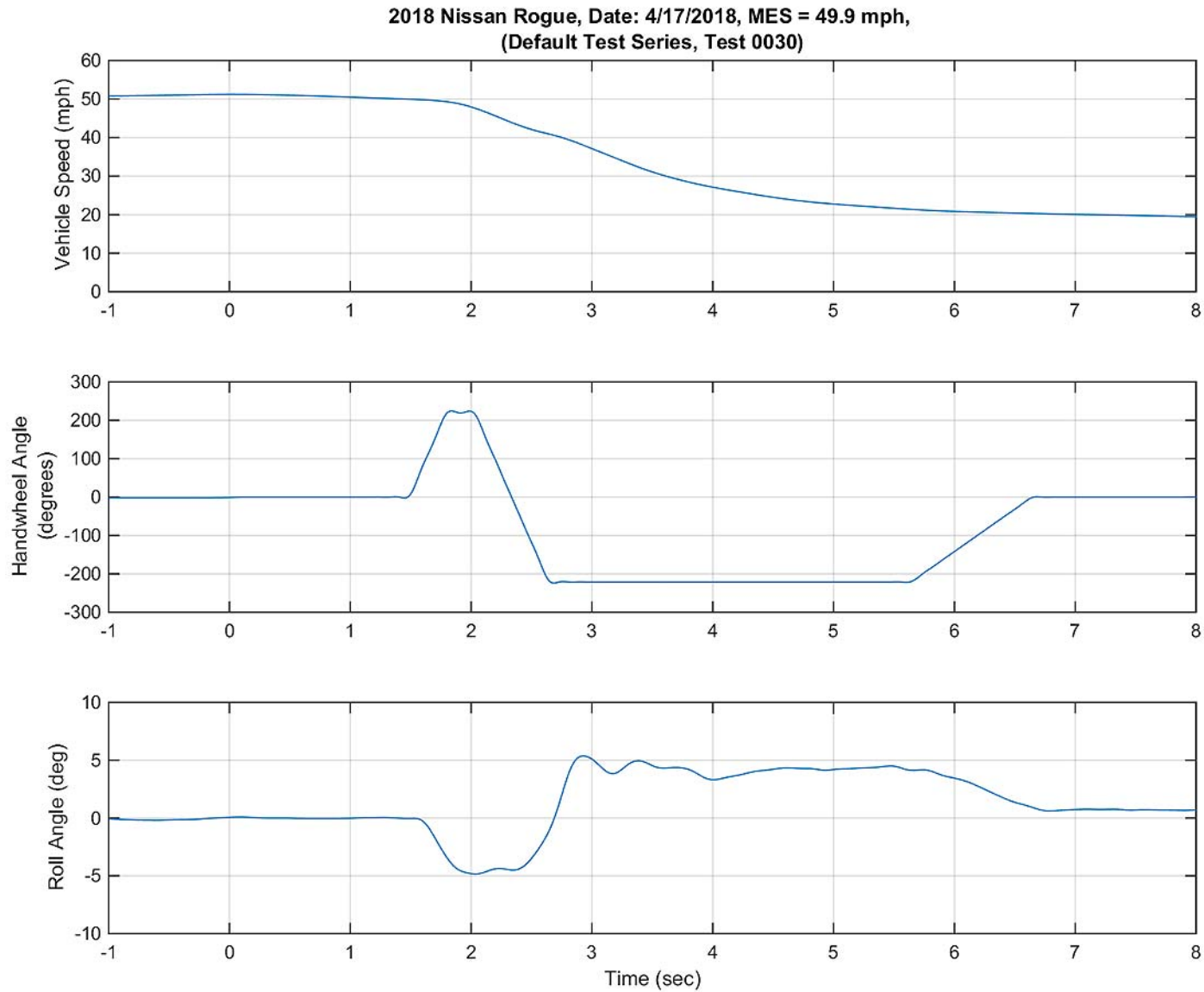

Figure D5. Vehicle Speed, Handwheel Angle, and Roll Angle Time History Plots for Default Test Series, R-L, 50 mph

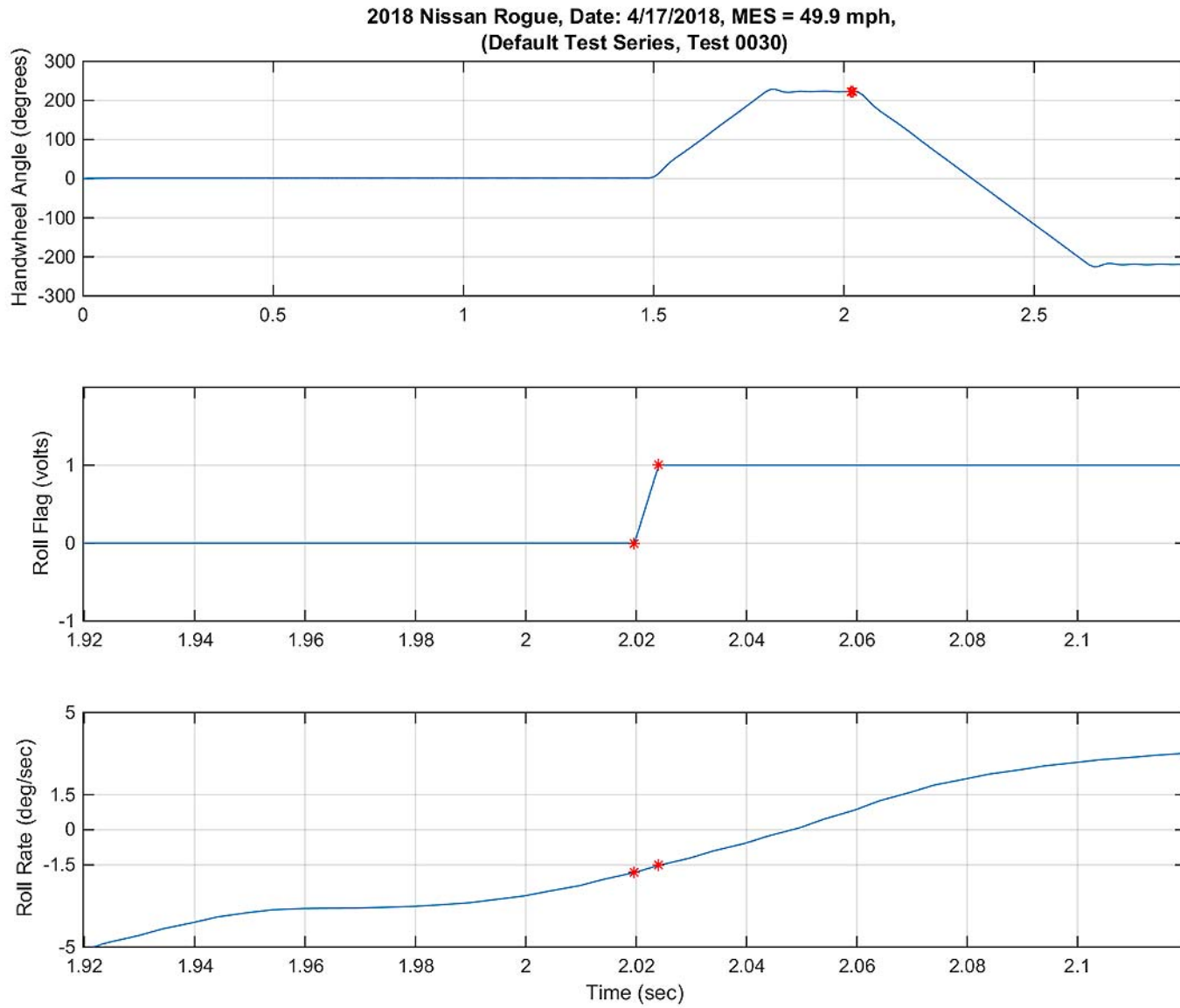

Figure D6. Steering Machine Operation Time History Plots for Default Test Series, R-L, 50 mph

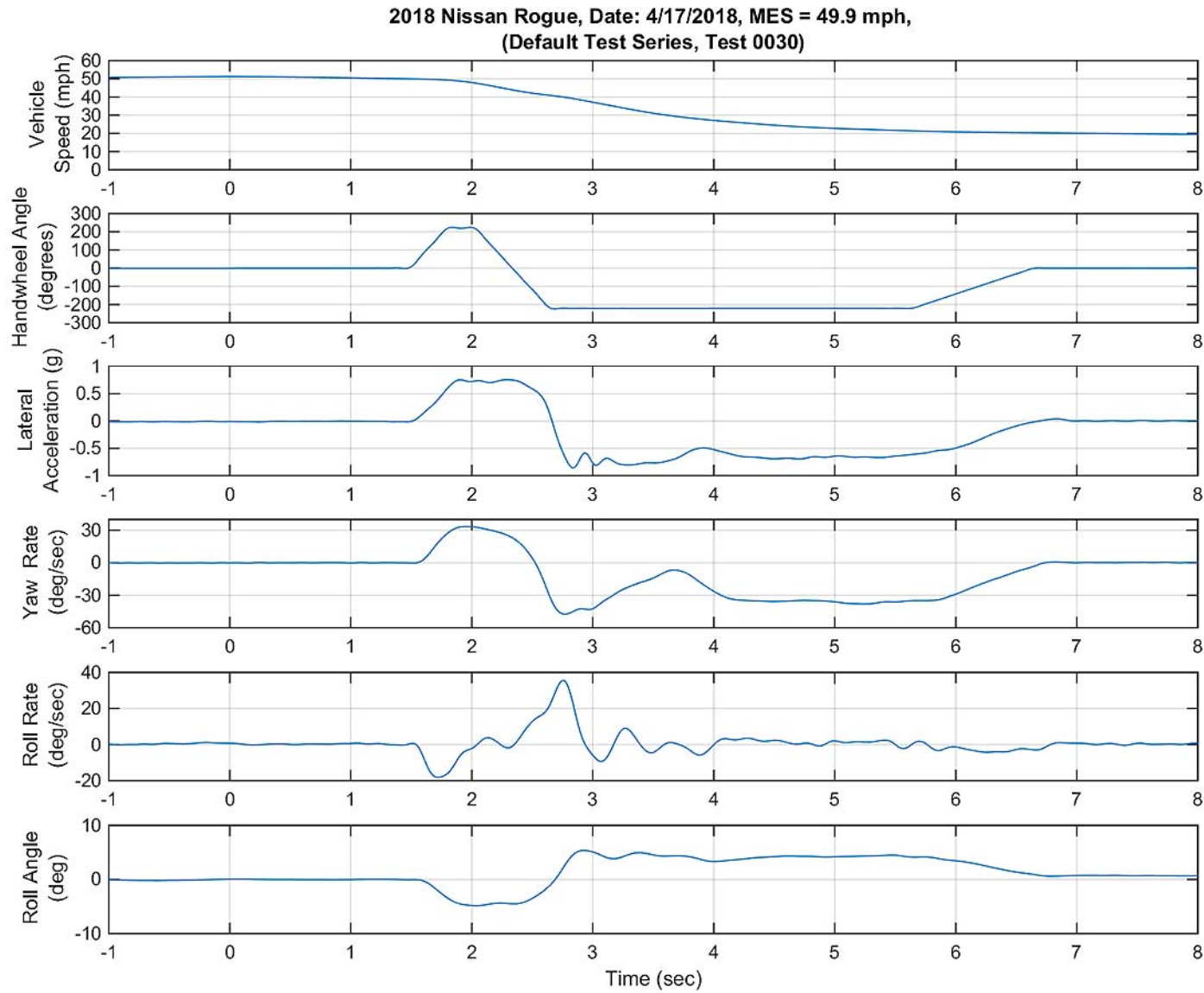

Figure D7. Yaw Rate, Roll Rate, and Lateral Acceleration Time History Plots for Default Test Series, R-L, 50 mph

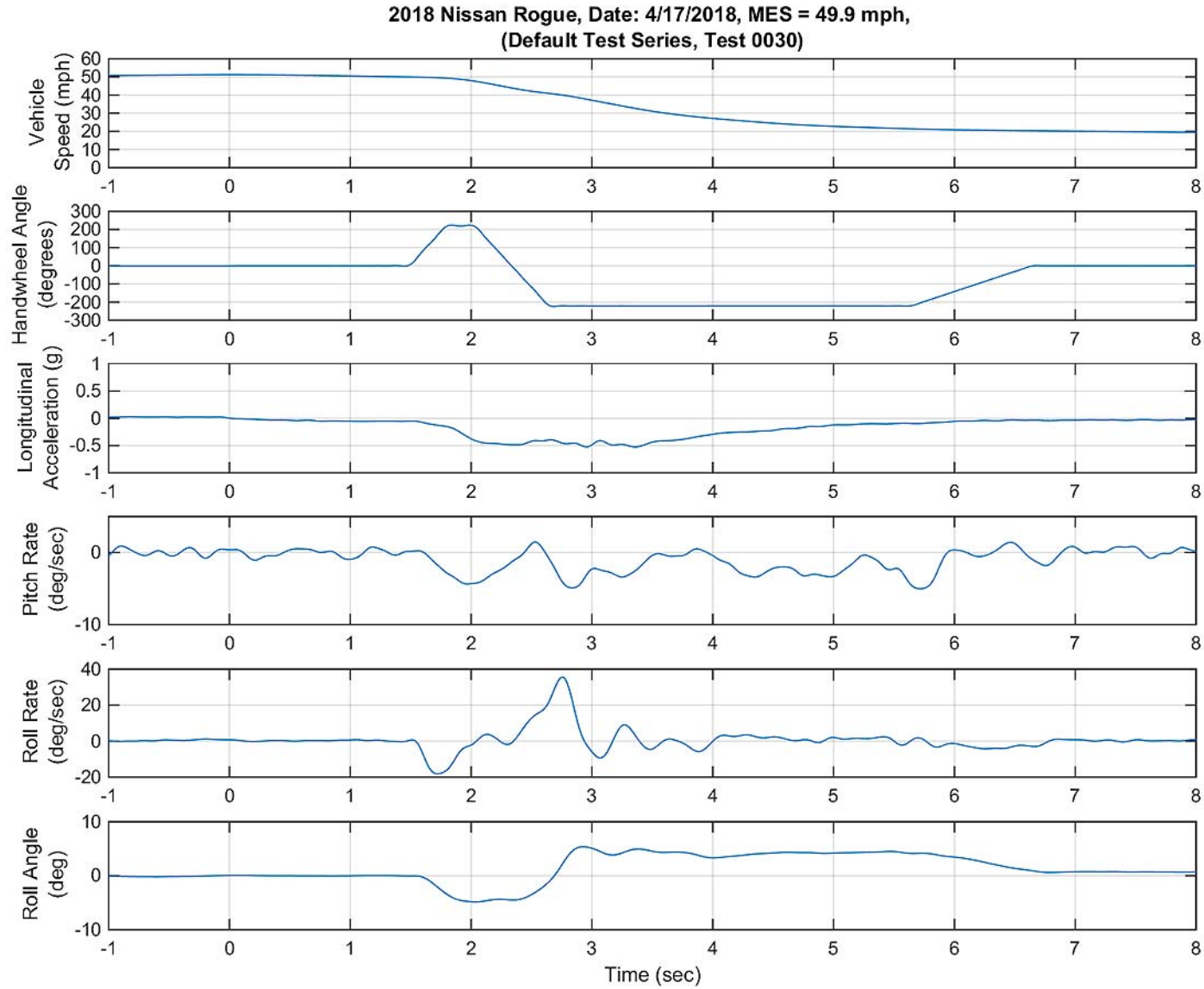

Figure D8. Pitch Rate and Longitudinal Acceleration Time History Plots or Default Test Series, R-L, 50 mph

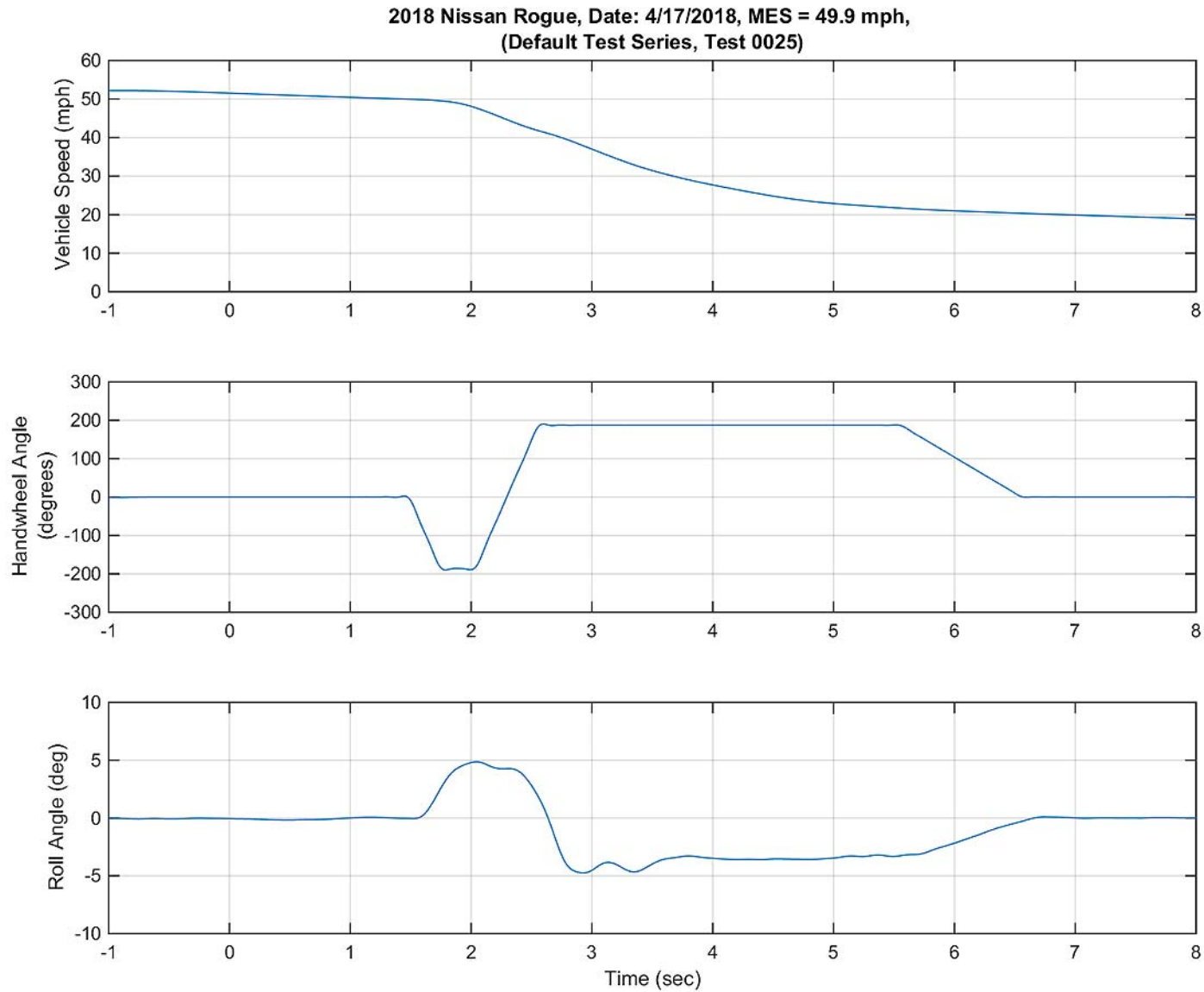

Figure D9. Vehicle Speed, Handwheel Angle, and Roll Angle Time History Plots for Supplemental 2 Test Series, L-R, 50 mph

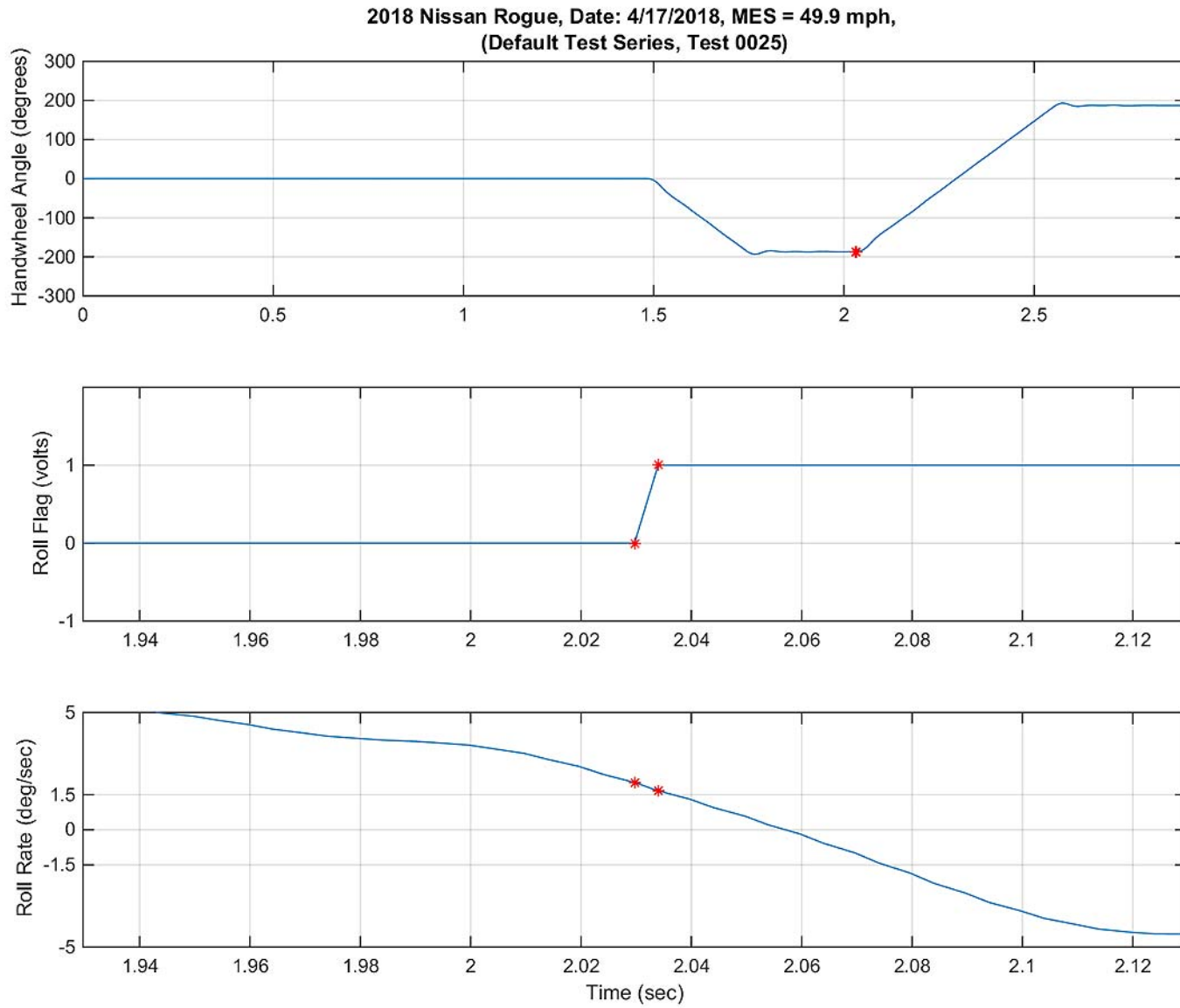

Figure D10. Steering Machine Operation Time History Plots for Supplemental 2 Test Series, L-R, 50 mph

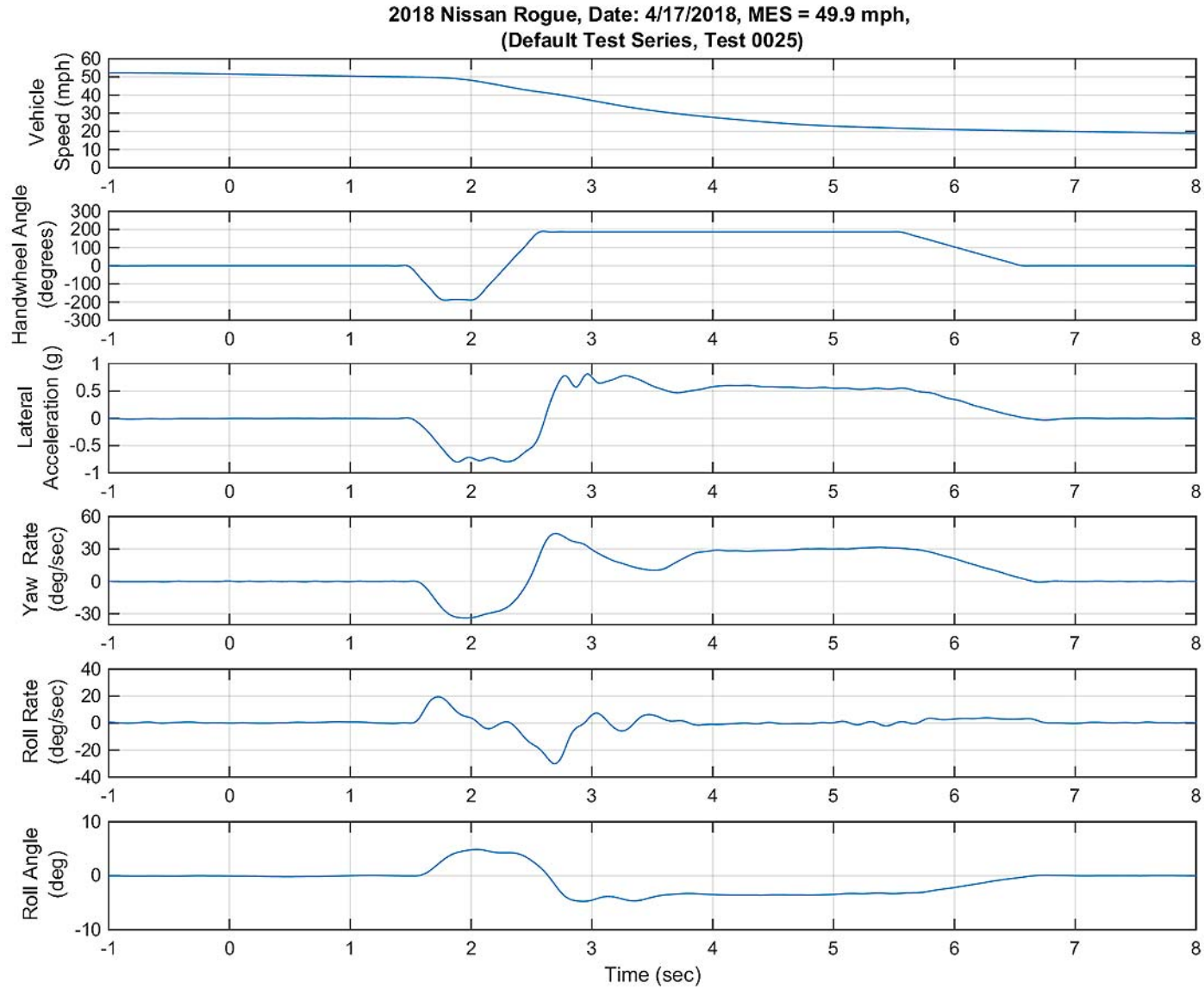

Figure D11. Yaw Rate, Roll Rate, and Lateral Acceleration Time History Plots for Supplemental 2 Test Series, L-R, 50 mph

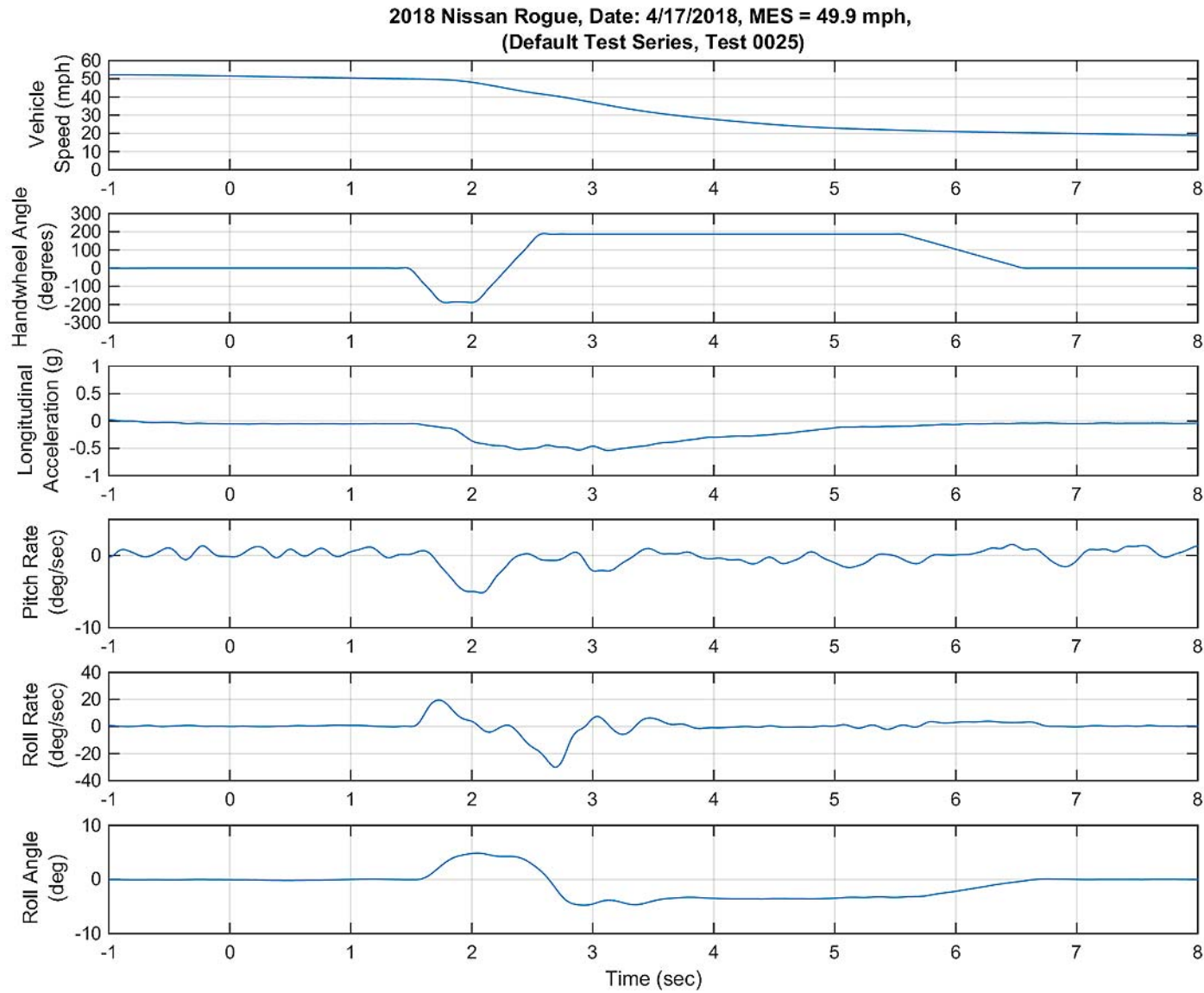

Figure D12. Pitch Rate and Longitudinal Acceleration Time History Plots for Supplemental 2 Test Series, L-R, 50 mph

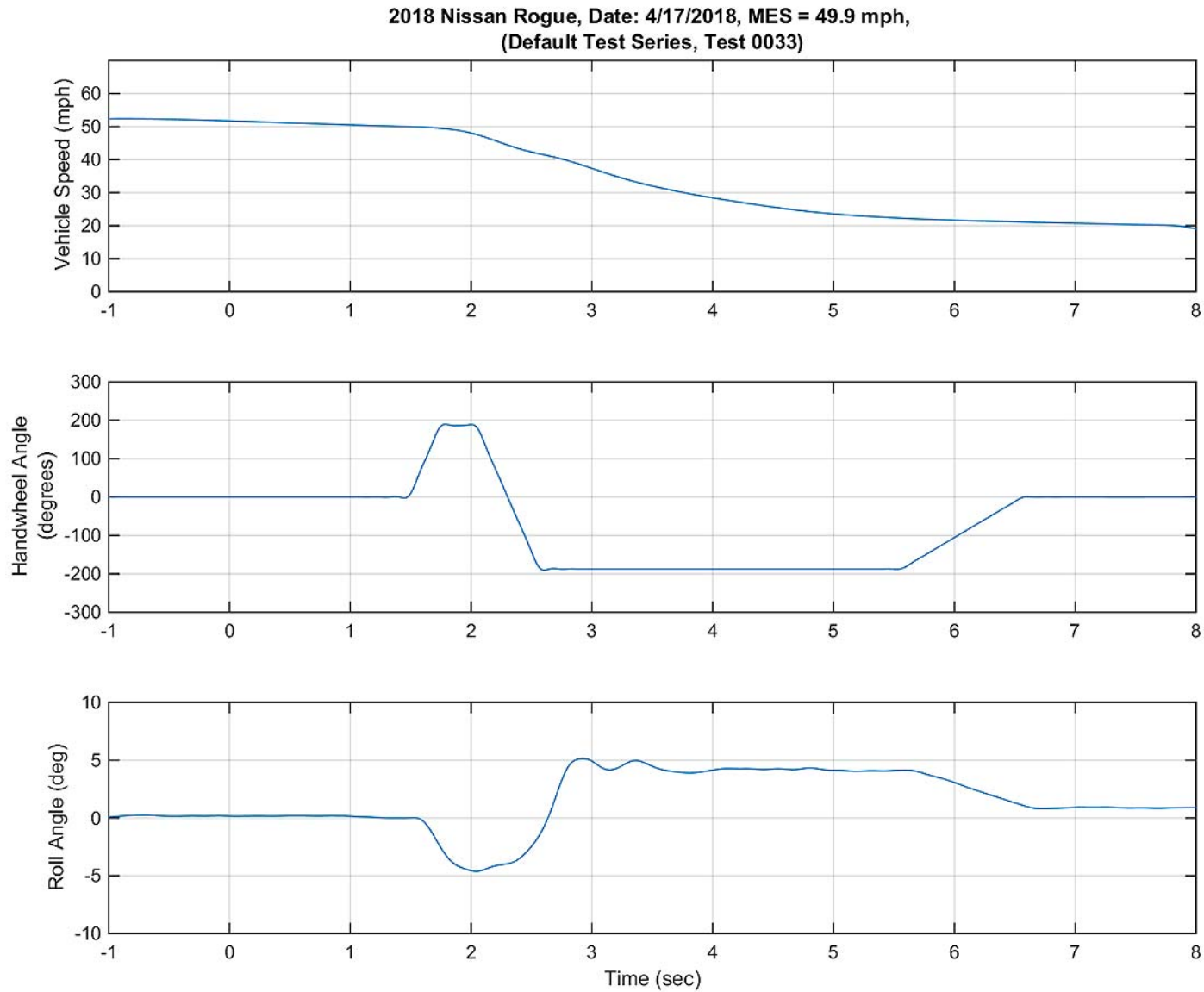

Figure D13. Vehicle Speed, Handwheel Angle, and Roll Angle Time History Plots for Supplemental 2 Test Series, R-L, 50 mph

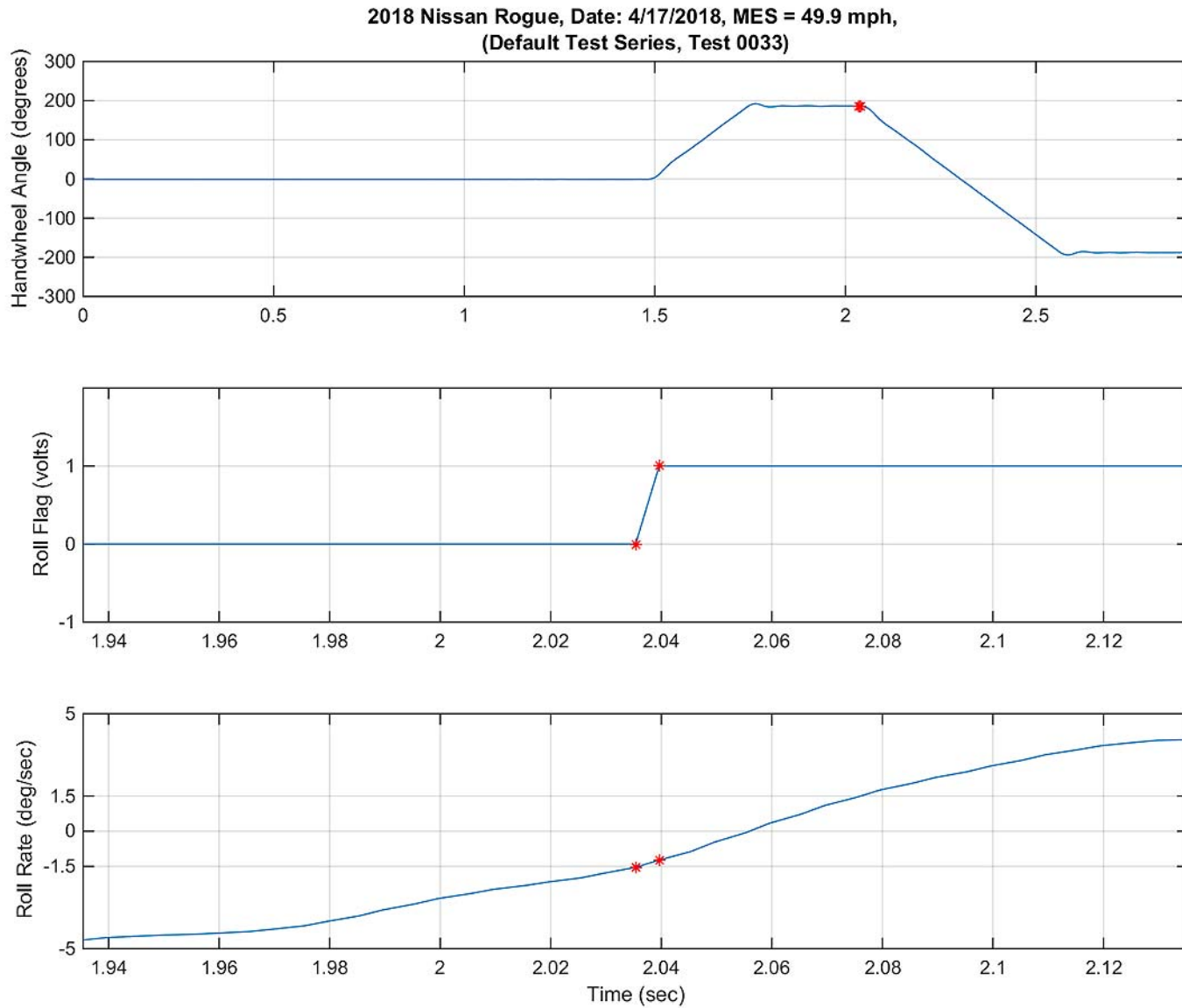

Figure D14. Steering Machine Operation Time History Plots for Supplemental 2 Test Series, R-L, 50 mph

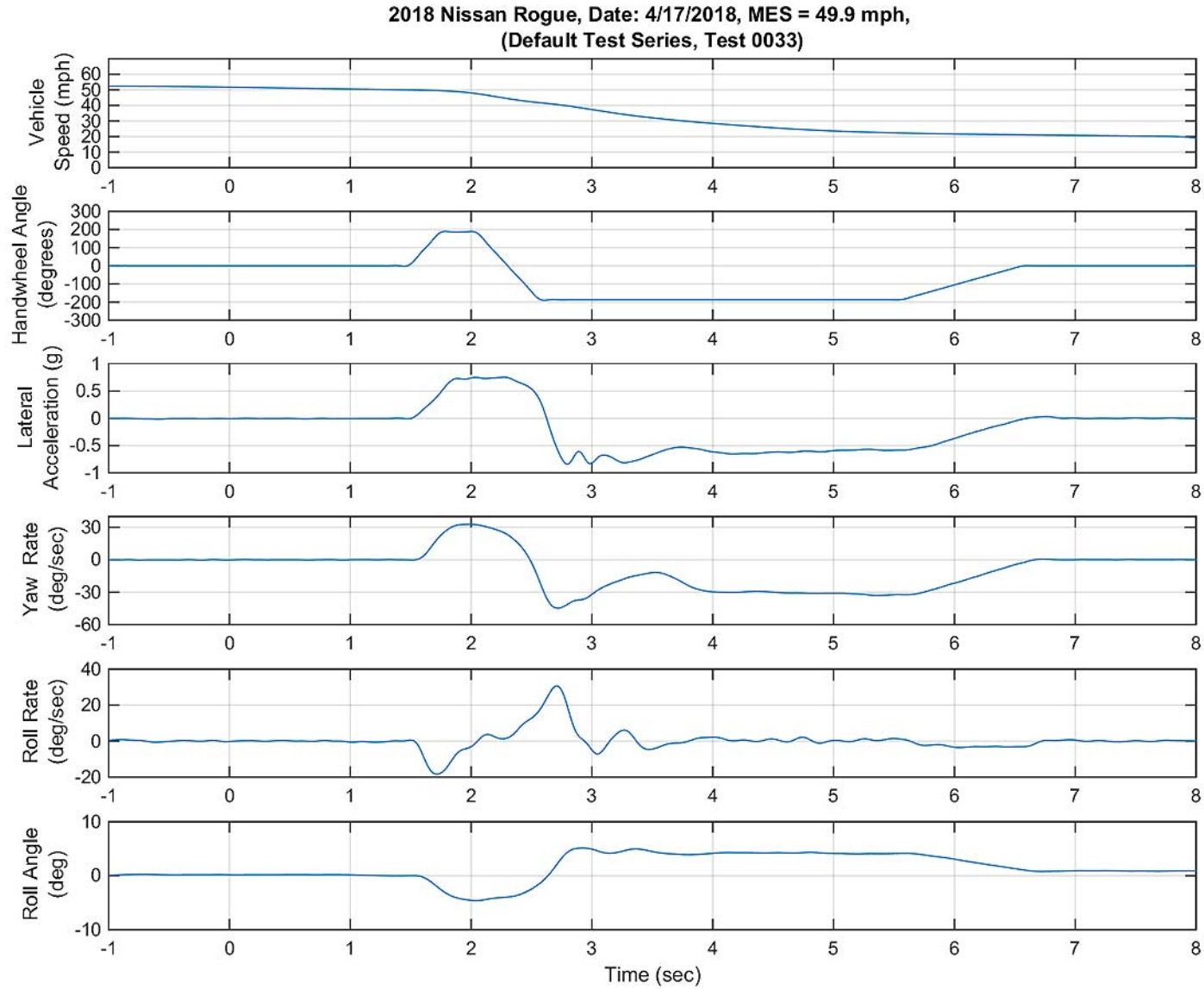

Figure D15. Yaw Rate, Roll Rate, and Lateral Acceleration Time History Plots for Supplemental 2 Test Series, R-L, 50 mph

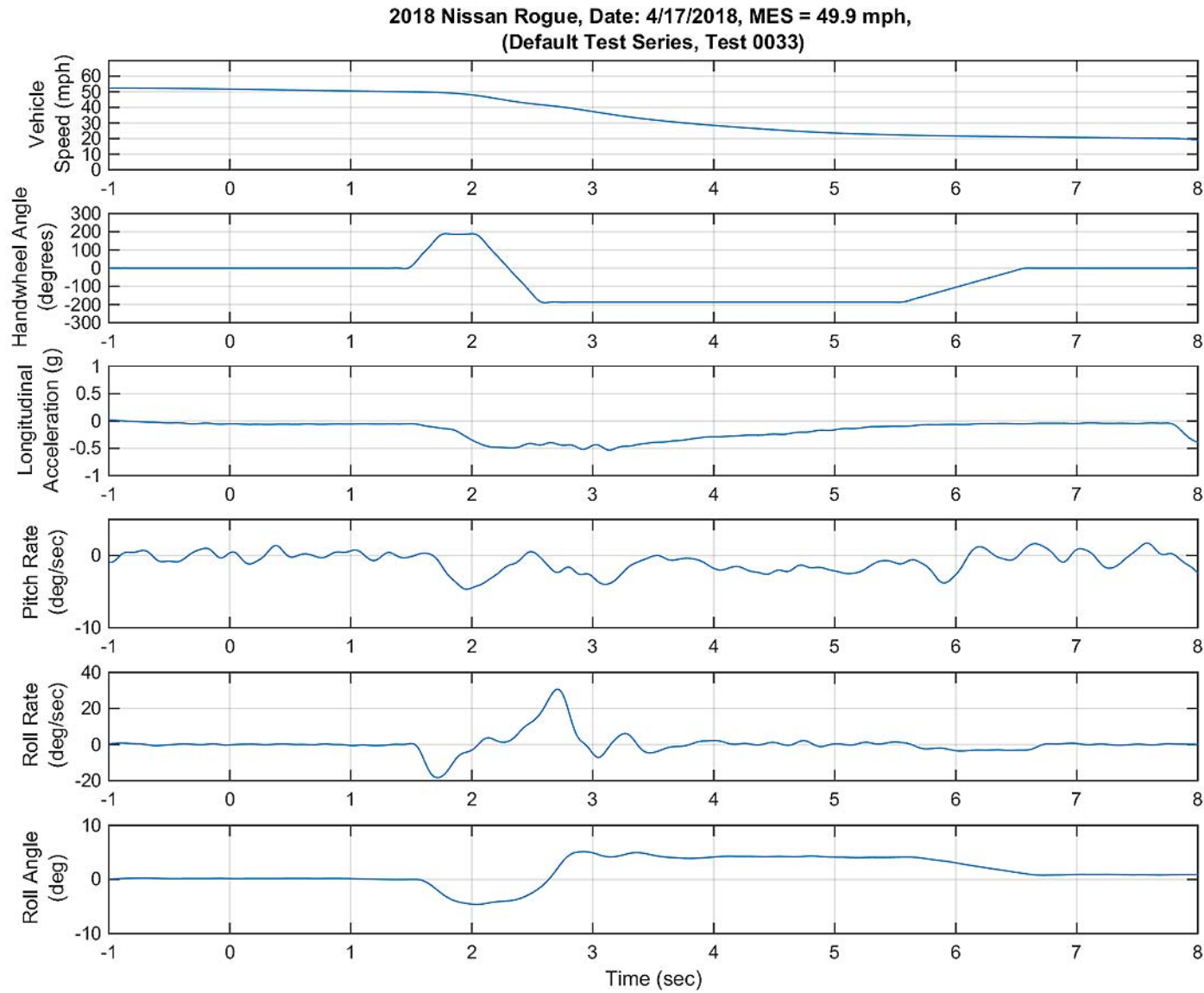

Figure D16. Pitch Rate and Longitudinal Acceleration Time History Plots for Supplemental 2 Test Series, R-L, 50 mph