

**NEW CAR ASSESSMENT PROGRAM (NCAP)  
DYNAMIC ROLLOVER RESISTANCE TEST**

FORD MOTOR COMPANY

2017 Ford F250 4WD

TEST NUMBER: 17-09

Final Report  
17 January 2017



Prepared by:

Dynamic Research, Inc  
355 Van Ness Ave. #200  
Torrance, CA 90501

Prepared for:

National Highway Traffic Safety Administration  
Office of Crash Avoidance Standards  
1200 New Jersey Avenue S.E.  
Washington, DC 20590

The United States Government assumes no liability for the contents of this report or use thereof. If trade or manufacturers' names or products are mentioned, it is only because they are considered essential to the object of the publication and should not be construed as an endorsement. The United States Government does not endorse products or manufacturers.

Dynamic Research, Inc. does not endorse or certify products of manufacturers. The manufacturer's name appears solely to identify the test article. Dynamic Research, Inc. assumes no liability for the report or use thereof. It is responsible for the facts and the accuracy of the data presented herein. This report does not constitute a standard, specification, or regulation.

Report Prepared by:



John Lenkeit, Program Manager

Date: 17 January 2017

Report Approved by:



Peter Broen, Principal Engineer

Date: 17 January 2017

1. Report No. <b>17-09</b>	2. Government Accession No.	3. Recipient's Catalog No.	
4. Title and Subtitle <b>NCAP Dynamic Rollover Resistance Maneuver (Fishhook) Test of a 2017 Ford F250 4WD TRUCK</b>		5. Report Date <b>17 January 2017</b>	6. Performing Organization Code <b>DRI</b>
		8. Performing Organization Report No. <b>DRI- TM-16-205</b>	
7. Author(s) <b>John Lenkeit, Program Manager Peter Broen, Project Engineer</b>		10. Work Unit No. (TRAIS)	
9. Performing Organization Name and Address <b>Dynamic Research, Inc. 355 Van Ness Ave. #200 Torrance, CA 90501</b>		11. Contract or Grant No. <b>DTNH22-14-D-00332</b>	
		13. Type of Report and Period Covered <b>Final Report November 2016 to December 2016</b>	
12. Sponsoring Agency Name and Address  <b>National Highway Traffic Safety Administration Office of Crash Avoidance Standards 1200 New Jersey Avenue S.E. Washington, DC 20590</b>		14. Sponsoring Agency Code	
		15. Supplemental Notes	
16. Abstract  An NCAP Dynamic Rollover Maneuver (Fishhook) Test was conducted on a 2017 Ford F250 4WD at Dynamic Research, Inc. on November 23, 2016. The vehicle did not experience two-wheel lift. The vehicle's steering angle at 0.3g lateral acceleration at 50 mph was 50.9 degrees.			
17. Key Words <b>NCAP Rollover Resistance Ratings Fishhook Test</b>		18. Distribution Statement Copies of this report are available from: National Highway Traffic Safety Admin. Office of Crash Avoidance Standards 1200 New Jersey Ave., S.E. Washington, DC 20590	
19. Security Classif. (of this report) <b>Unclassified</b>	20. Security Classif. (of this page) <b>Unclassified</b>	21. Number of Pages <b>50</b>	22. Price

## TABLE OF CONTENTS

	Page
I. INTRODUCTION.....	1
II. VEHICLE PREPARATION .....	2
A. Test Vehicle .....	2
B. Tires .....	2
C. Vehicle Loading.....	2
D. Steering Controller .....	5
E. Instrumentation and Data Collection .....	5
F. Other Vehicle Preparation .....	5
III. TEST PROCEDURES.....	8
A. Test Procedure Overview.....	8
B. Test Conditions .....	9
IV. RESULTS.....	12
APPENDIX A Photographs .....	A-1
APPENDIX B Test Run Log.....	B-1
APPENDIX C Slowly Increasing Steer Test Worksheet.....	C-1
APPENDIX D Time History Plots .....	D-1

## LIST OF FIGURES

	Page
1. Nominal Position of Video Cameras for Fishhook Tests .....	8
2. DRI-Minter Vehicle Dynamics Area .....	12

## LIST OF TABLES

	Page
1. Test Vehicle Data .....	3
2. Tire Information .....	4
3. Vehicle Loading .....	4
4. Sensors .....	7
5. Surface Friction .....	10
6. Handwheel Angles .....	11
7. Weather Conditions .....	11

## Section I INTRODUCTION

Beginning with the 2006 fiscal year, the National Highway Traffic Safety Administration (NHTSA) has engaged Dynamic Research, Inc. (DRI) of Torrance, CA to conduct dynamic rollover testing and gather data from that testing as part of NHTSA's New Car Assessment Program (NCAP).

The purpose of the testing reported herein was to determine if a typical 2017 Ford F250 4WD would experience tip-up, defined as simultaneous two-wheel lift of two inches or more at an entry speed of 50 mph or less in the Fishhook Procedure developed by NHTSA. This procedure may be found at [www.regulations.gov](http://www.regulations.gov), docket item NHTSA-2006-26555-0136.

The testing reported herein was accomplished under contract DTNH22-14-D-00332. The task order is entitled, "New Car Assessment Program (NCAP) Non-Destructive Vehicle Testing and Data Gathering."

## Section II VEHICLE PREPARATION

### A. TEST VEHICLE

The test vehicle was new or in as-new condition, meaning the vehicle had been driven no more than 500 miles prior to the start of dynamic rollover testing. It was acquired through a commercial rental/leasing company. Details of the test vehicle are given in Table 1.

### B. TIRES

All tires used were new, and of the same make, model, size, and DOT specification of those installed on the vehicle when purchased new. Tire inflation pressures were in accordance with the recommendations indicated on each vehicle's identification placard. To reduce the possibility of tire debanding during Fishhook testing, an appropriately sized inner tube was installed in each tire. To further reduce the possibility of tire debanding, the tires were mounted to the rims without the use of tire mounting lubricant. Tire specifications are listed in Table 2.

### C. VEHICLE LOADING

The multi-passenger load, described in the Fishhook Procedure, was used for all tests. The load and positioning of the load in the vehicle are listed in Table 3.

In addition to water dummies, the loading included instrumentation, a steering machine, and outriggers. Test vehicle bumper assemblies were removed for outrigger installation. The reduction in vehicle weight due to the removal of the bumpers was offset by the additional weight of the outriggers and their mounting system. The outrigger system typically outweighs the bumper assemblies.



Table 1. Test Vehicle Data

<b>General Data</b>					
Model year, make, model	2017 Ford F250 4WD				
VIN	1FT7W2BT4HEB2xxxx				
Body style	TRUCK				
Number of doors	4				
Trim level					
Seating positions	Front:	2 <sup>nd</sup> row	3 <sup>rd</sup> row	4 <sup>th</sup> row	5 <sup>th</sup> row
	3	3	0	0	0
Electronic stability control	Yes				
4-Wheel ABS (Yes/No)	Yes				
Power steering (Yes/No)	Yes				
Major optional equipment					
Odometer at start of testing	133 miles				
<b>Drivetrain</b>					
Engine cylinder arrangement	V-8				
Engine displacement	6.7 L				
Transmission type	Automatic				
Drive arrangement	4WD				
<b>Chassis</b>					
Track width	F: 68.5 in (1739.9 mm) , R: 67.25 in (1708.2 mm)				
Wheelbase	160 in (4064 mm)				
Curb weight	6833 lb (3099.4 kg)				
<b>Certification Data from Vehicle's Label</b>					
Vehicle manufactured by	FORD MOTOR COMPANY				
Date of manufacture	8/16				
GVWR	10000 lb (4536 kg)				
GAWR Front	5200 lb (2359 kg)				
GAWR Rear	6340 lb (2876 kg)				

Table 2. Tire Information

Tire Manufacturer	Continental
Tire Model	Contitrac
Tire Size	Front: 275/65r18 Rear: 275/65r18
Load rating	Front: 123/120 Rear: 123/120
Speed rating	Front: S Rear: S
Treadwear grade	Front: NA Rear:
Traction grade	Front: NA Rear:
Temperature grade	Front: NA Rear:
Location of "Recommended Tire Pressure" label	Driver's Door jamb
Recommended cold tire pressure	Front: 60 psi, (420 kPa) Rear: 75 psi, (520 kPa)
First 8 digits of DOT code	Front: A3V9 H00R Rear: A3V9 H00R

Table 3. Vehicle Loading

Water dummy and other loading	3 water dummies in second row
Water dummy weight	175 lb (79.4 kg)
Fuel level	Full
<b>Weight as Tested</b>	
Left front	2555 lb (1158.9 kg)
Right front	2417 lb (1096.3 kg)
Left rear	1760 lb (798.3 kg)
Right rear	1660 lb (753 kg)

## D. STEERING CONTROLLER

A programmable steering machine was installed which generates handwheel steering inputs for all test maneuvers. The machine provides at least 35 lb-ft of torque at a handwheel rate of 720 deg/sec, is capable of actuating the vehicle's steering system through its full range, and accepts angular rate sensor feedback input for roll rate-induced steering reversals.

## E. INSTRUMENTATION AND DATA COLLECTION

The test vehicle was instrumented with an angle encoder, located in the steering controller; a 3-axis inertial measurement unit to measure roll, pitch, and yaw rates, and longitudinal, lateral, and vertical acceleration; two ultrasonic distance measuring sensors to measure vehicle roll angle; and a radar speed sensor to measure vehicle speed. The brake light circuit was monitored to verify that there was no brake pedal application during any test.

A list of the sensors is given in Table 4. A 3B signal conditioning and power rack was used to provide any necessary sensor power, excitation, gain, and offset. Two pole Butterworth anti-alias filters were used for all analog data channels, using a corner frequency of 20 Hz. Data were collected at 200 samples/sec, using a Measurement Computing Corp. PCI-DAS6402/16 A/D board.

Two video cameras were used to record the Fishhook runs. They were positioned nominally as shown in Figure 1. The recorded videotapes were reviewed after the Fishhook runs to check for any two wheel lift. If any two wheel lift was observed, eight infrared distance measuring sensors for measurement of wheel lift (two sensors at each wheel) were then mounted for use in subsequent confirmation Fishhook tests.

## F. OTHER VEHICLE PREPARATION

In addition to installation and preparation discussed above, the test vehicle was prepared as follows:

- Front and rear bumpers were removed
- Outrigger mounts were installed in the bumper locations and titanium outriggers were fastened to these mounts
- A five point safety harness was installed.
- Airbags were removed or otherwise disabled

Photographs of the vehicle tested are given in Appendix A.

Table 4. Sensors

Data Measured	Type	Range	Manufacturer	Model Number
Handwheel angle	Encoder	Infinite	Heitz Automotive Testing, Inc.	Angle encoder integral with steering controller
Brake pedal actuation	Tape Switch	On/Off	Vericom Computers	VC3000
Longitudinal, lateral, and vertical acceleration	Multi-axis inertial sensing system	$\pm 2$ g	BEI Technologies, Inc., Systron Donner Inertial Division	MP-1
Roll, pitch, and yaw rate		$\pm 100$ deg/s		
Left and right side vehicle ride height (to measure roll angle)	Ultrasonic distance measuring system	50 – 400 mm	Texense	RH550-400
Vehicle speed	Radar speed sensor	0 - 100 mph	Racelogic VBox	VBSS100-V3
Wheel lift (via resolution of two measured distances spaced a known distance apart), used for confirmation tests only	Analog displacement measuring system (Infrared; 880 mm)	13.8 - 33.5 in	Wenglor Sensors, Ltd.	HT 66MGV80

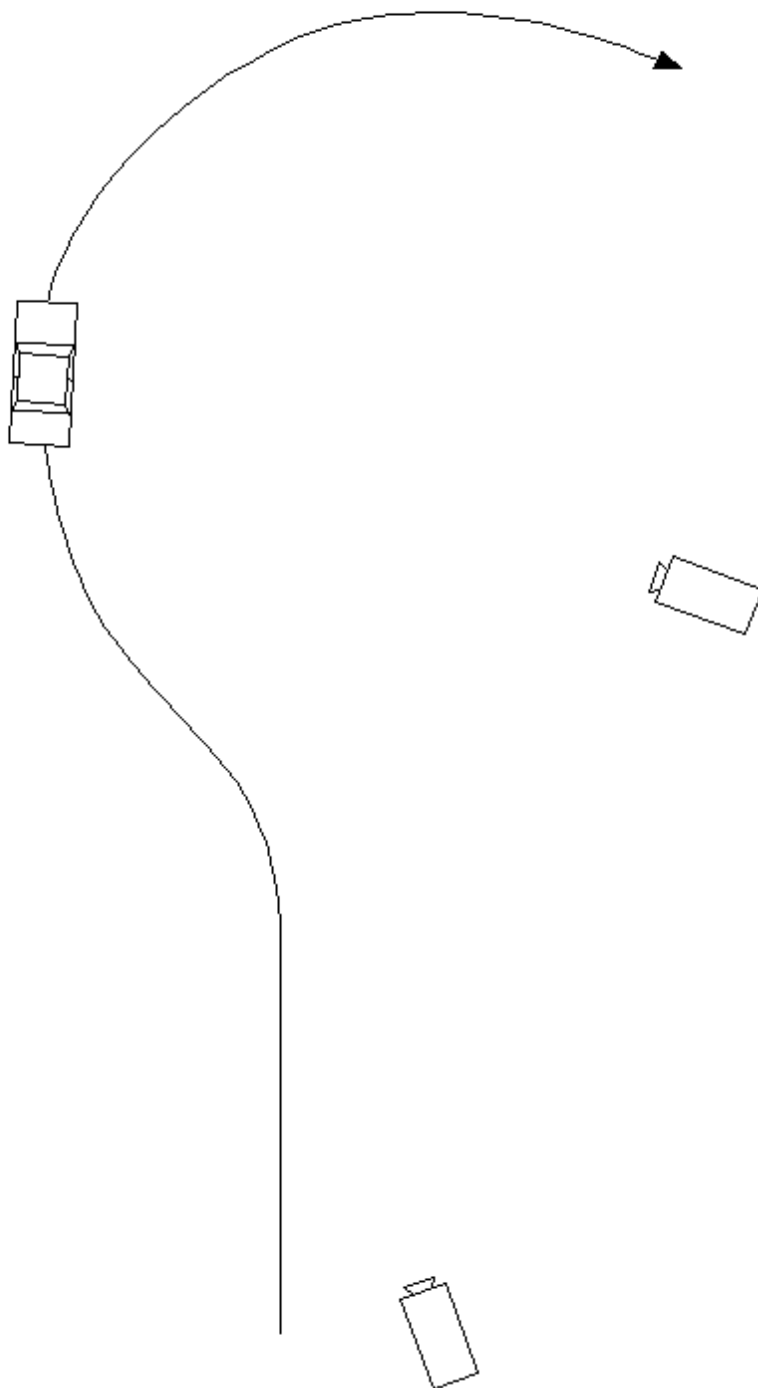

Figure 1. Nominal Position of Video Cameras for Fishhook Tests

### Section III TEST PROCEDURES

This section includes a general overview of the test procedures and details of the particular test.

#### A. TEST PROCEDURE OVERVIEW

This test was conducted in accordance with NHTSA's NCAP Rollover Resistance Test Procedure (Fishhook) as described in the Federal Register (68 FR 59250). Detailed descriptions of the test procedure, pass/fail criteria, and data acquisition specifications may be found at docket NHTSA-2001-9663.

There are two major components of the test procedure, the Slowly Increasing Steer (SIS) pre-test and the Fishhook test.

The Slowly Increasing Steer (SIS) maneuver was used to characterize the steady state lateral dynamics of each vehicle, and is based on the "Constant Speed, Variable Steer" test defined in SAE J266. The maneuver is used to determine the handwheel angle that produces a lateral acceleration of 0.3 g at 50 mph. This handwheel angle is then used to determine the magnitude of steering to be used for the NHTSA Fishhook maneuver.

SIS tests were performed at a constant speed of 50 mph. Handwheel angle was input at a rate of 13.5 deg/sec, from 0 to an angle that provided at least 0.55 g. Three tests were conducted in each direction, and the data for the six runs were averaged to obtain the handwheel angle that produced 0.3 g at 50 mph.

The Fishhook test is a programmed steering maneuver that is implemented via the steering controller. The vehicle was initially steered in one direction and then the steering was reversed. The timing, magnitude and rate of the steering were prescribed by the Fishhook Procedure.

To begin the maneuver, the vehicle was driven in a straight line at a speed slightly greater than the desired entrance speed. The driver then released the throttle. When the vehicle was at the target speed, the steering controller automatically initiated the steering maneuver. Following completion of the steering reversal the handwheel position was maintained for three seconds, and then returned to zero angle in 1 second.

The tests were conducted in both left-right and right-left directions. The “Default” test series used a handwheel angle equal to 6.5 times the handwheel angle that produced 0.3 g at 50 mph in the SIS tests, and initial vehicle speeds beginning at 35 mph and concluding up to 50 mph (if no two-wheel lift occurs). Supplemental tests were also done, as specified in the Fishhook Procedure.

## B. TEST CONDITIONS

### 1. Test Surface

The tests were conducted on the Vehicle Dynamics Area at DRI’s Minter Field facility, located near Bakersfield, California, on 11/23/2016. The VDA has a smooth, flat (slope less than 0.5% throughout) asphaltic concrete surface. Its dimensions are as shown in Figure 2. It was built in the spring of 2005.

VDA surface friction measurements were accomplished using the DRI Mobile Tire Tester. Three runs were done, one at each of three previously determined locations. Each run provided for a minimum of 3 seconds of tire friction at constant normal load, slip angle, and speed in a free rolling condition. The test was accomplished using an ASTM E1136 tire with an inflation pressure of 35 ( $\pm 0.5$ ) psi at a test speed of 40 ( $\pm 0.5$ ) mph. The net slip angle of the test tire for each test run was 7.5 deg. The test tire was no older than 6 months from the date of manufacture. The surface friction measurement results are shown in Table 5.

Table 5. Surface Friction

Date of surface friction measurements	11/22/2016
Average normalized lateral force	0.938

### 2. Fishhook Handwheel Angles

The 0.3g handwheel angle obtained from the SIS tests and the handwheel angles used in the Fishhook tests are shown in Table 6.

Table 6. Handwheel Angles

0.3g handwheel angle (from SIS tests at 50 mph)	50.9 °
5.5 scalar handwheel angle for Fishhook Test	280°
6.5 scalar handwheel angle for Fishhook Test	331 °

### 3. Weather Conditions

The weather conditions, recorded at the end of testing, are shown in Table 7.

Table 7. Weather Conditions

Ambient temperature	48 °F ( 9 °C)
Wind Speed	3 mph (1.3 m/s)
Wind Direction	W-SW



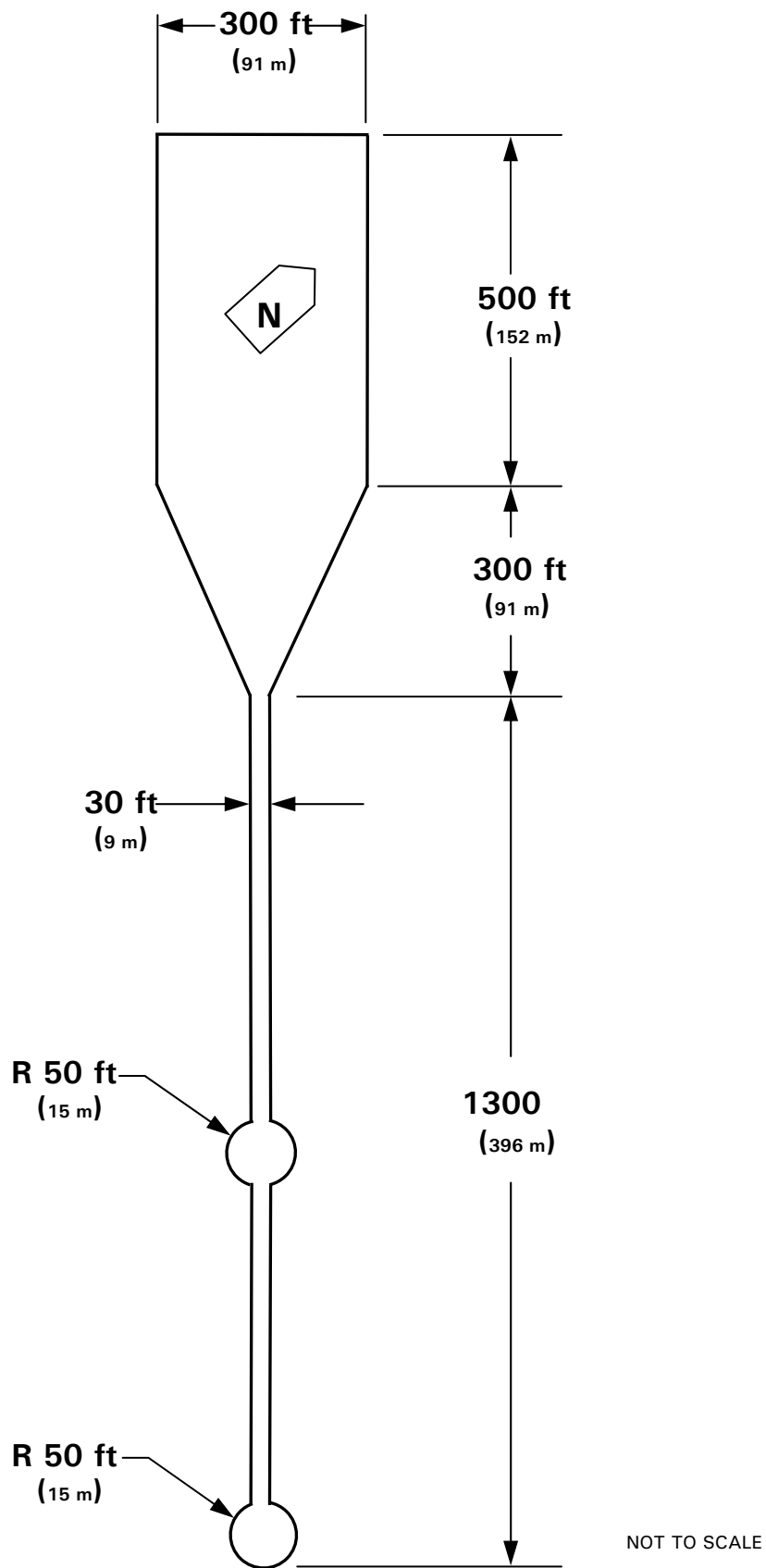

Figure 2. DRI-Minter Vehicle Dynamics Area

## Section IV RESULTS

The test run log is given in Appendix B. The Slowly Increasing Steer Test Worksheet is given in Appendix C. Appendix D contains time history plots for the 50 mph runs and any runs which resulted in two-wheel lift. For the 2017 Ford F250 4WD, there was no two-wheel lift at any test condition.

APPENDIX A

Photographs

LIST OF FIGURES

	Page
A1. Window Sticker.....	A-3
A2. Front View, Test Vehicle as Delivered .....	A-4
A3. Rear View, Test Vehicle as Delivered .....	A-5
A4. Front View, Test Vehicle in Test Condition.....	A-6
A5. Rear View, Test Vehicle in Test Condition .....	A-7
A6. Instrumentation in Test Vehicle .....	A-8
A7. Ballast Condition.....	A-9



Figure A1. Window Sticker



**VEHICLE DESCRIPTION**  
**SUPER DUTY**  
 2017 F250 SRW 4x4 CREW CAB  
 XL1 160" WB STYLESIDE  
 6.7L POWER STROKE V8 DIESEL  
 6-SPEED AUTO TRANS

**EXTERIOR**  
 INCOAT SILVER METALLIC  
**INTERIOR**  
 MEDIUM EARTH GRAY

**STANDARD EQUIPMENT INCLUDED AT NO EXTRA CHARGE**

- |  |   |  |   |
|--|---|--|---|
| <p><b>EXTERIOR</b></p> <ul style="list-style-type: none"> <li>• BOXLINK™</li> <li>• BUMPERS - CHROME</li> <li>• GRILLE - 2-BAR, CHROME</li> <li>• LOCKING REMOVABLE TAILGATE W/ LIFT ASST -NA W/BOX DLT</li> <li>• PICKUP BOX, TIE DOWN HOOKS -NA W/BOX DLT</li> <li>• REAR PRIVACY GLASS</li> <li>• SPARE TIRE AND WHEEL LOCK -NA W/BOX DLT</li> <li>• TOW HOOKS</li> <li>• TRAILER SWAY CONTROL</li> </ul> | <p><b>INTERIOR</b></p> <ul style="list-style-type: none"> <li>• 1 TOUCH UP/DOWN DR/PASS WIN</li> <li>• 60/40 REAR BENCH W/FLIP-UP</li> <li>• FLIP-DOWN W/HEAD RSTRNT</li> <li>• UNDER-SEAT STORAGE</li> <li>• AIR COND, MANUAL FRONT</li> <li>• CLOTH SUN VISORS</li> <li>• CRUISE CONTROL</li> <li>• OUTSIDE TEMP DISPLAY</li> <li>• PARTICULATE AIR FILTER</li> <li>• POWER LOCKS AND WINDOWS</li> <li>• TILT/TELESCOPE STR COLUMN</li> </ul> | <p><b>FUNCTIONAL</b></p> <ul style="list-style-type: none"> <li>• 4 WHEEL ANTI-LOCK DISC BRAKING SYSTEM</li> <li>• HILL START ASSIST</li> <li>• JEWEL EFFECT HEADLAMPS</li> <li>• MANUAL LOCKING HUBS</li> <li>• MONO BEAM COIL SPRING FRT SUSPENSION W/STAB BAR</li> <li>• MYKEY</li> <li>• REMOTE KEYLESS ENTRY</li> <li>• TRAILER BRAKE CONTROLLER</li> </ul> | <p><b>SAFETY/SECURITY</b></p> <ul style="list-style-type: none"> <li>• ADVANCTRAC WITH RSC</li> <li>• AIRBAGS - SAFETY CANOPY</li> <li>• DRIVER/PASSENGER AIR BAGS</li> <li>• PERIMETER ALARM</li> <li>• SOS POST CRASH ALERT SYS</li> </ul> <p><b>WARRANTY</b></p> <ul style="list-style-type: none"> <li>• 3YR/36,000 BUMPER / BUMPER</li> <li>• 5YR/60,000 POWERTRAIN</li> <li>• 5YR/60,000 ROADSIDE ASSIST</li> </ul> |
|--|---|--|---|

INCLUDED ON THIS VEHICLE	(MSRP)	PRICE INFORMATION	(MSRP)
<b>OPTIONAL EQUIPMENT/OTHER</b>		<b>BASE PRICE</b>	\$44,090.00
PREFERRED EQUIPMENT PKG.603A	8,595.00	<b>TOTAL OPTIONS/OTHER</b>	11,390.00
6.7L POWER STROKE V8 DIESEL	NO CHARGE		
6-SPEED AUTO TRANS		<b>TOTAL VEHICLE &amp; OPTIONS/OTHER</b>	\$55,420.00
LT775/65R16E BSW ALL SEASON	390.00	<b>DESTINATION &amp; DELIVERY</b>	1,195.00
3.9L ELECTRONIC LOCKING AXLE	1,460.00		
XL1 VALUE PACKAGE			
FOG LAMPS			
ADJUSTABLE GAS/BRAKE PEDAL	570.00		
REVERSE VEHICLE AID SENSOR	185.00		
3-WAY POWER SEAT-DRIVER	185.00		
10000F GVWR PACKAGE	75.00		
NAVIGATION SYSTEM	NO CHARGE		
ELECTRONIC SHIFT ON THE FLY	NO CHARGE		
ENGINE BLOCK HEATER	NO CHARGE		
50 STATE EMISSIONS	NO CHARGE		
110V/400W OUTLET	NO CHARGE		
SPARE TIRE AND WHEEL	NO CHARGE		
JACK	NO CHARGE		
EXTRA HEAVY DUTY ALTERNATOR	NO CHARGE		
SYNC 3 VOICE ACTIVATED SYSTEMS	115.00		

**EPA DOT Fuel Economy and Environment**

**FUEL ECONOMY RATINGS NOT REQUIRED ON THIS VEHICLE**

**fuelconomygov**  
 Calculate personalized estimates and compare vehicles

**GOVERNMENT 5-STAR SAFETY RATINGS**

**Overall Vehicle Score** Not Rated  
 Based on the combined ratings of frontal, side and rollover. Should ONLY be compared to other vehicles of similar size and weight.

<b>Frontal Crash</b>	Driver	Not Rated
	Passenger	Not Rated

Based on the risk of injury in a frontal impact. Should ONLY be compared to other vehicles of similar size and weight.

<b>Side Crash</b>	Front seat	Not Rated
	Rear seat	Not Rated

Based on the risk of injury in a side impact.

<b>Rollover</b>	Not Rated
-----------------	-----------

Based on the risk of rollover in a single-vehicle crash.

Star ratings range from 1 to 5 stars (★★★★★), with 5 being the highest.  
 Source: National Highway Traffic Safety Administration (NHTSA).  
[www.safercar.gov](http://www.safercar.gov) or 1-888-327-4236

**39 YEARS**  
**FORD F-SERIES**  
 AMERICA'S BEST SELLING TRUCKS  
**BUILT FORD TOUGH**

<b>BOLD TO</b>	<b>RAMP ONE</b>	<b>DEALER NO.</b>	<b>TOTAL MSRP \$56,615.00</b>
	CS1P		
<b>SWAP TO</b>	<b>RAMP TWO</b>	<b>FINAL ASSEMBLY PLANT</b>	This label is affixed pursuant to the Federal Automobile Information Disclosure Act. Gasoline, License, and Title Fees, State and Local taxes are not included. Dealer installed options or accessories are not included unless listed above.
		KENTUCKY	
<b>SWAP THROUGH</b>	<b>METHOD OF TRANSP.</b>	<b>ITEM #:</b>	
	CONVOY		

1F17W2BT4HEB7

**FORD PROTECT**  
 Insist on Ford Protect! The only extended service plan fully backed by Ford and honored at every Ford dealership in the U.S., Canada and Mexico. See your Ford dealer for additional details, or visit [www.FordOwner.com](http://www.FordOwner.com) for more information.

**FORD CREDIT**  
 Choose the vehicle you want. Whether you decide to lease or finance, you'll find the choices that are right for you. See your Ford Dealer for details or visit [www.FordCredit.com](http://www.FordCredit.com).

Scan this code to experience this vehicle or text 1FHBE22634 to 48029 or visit [ford.com/windowssticker](http://ford.com/windowssticker)

Standard messaging & data plan rates may apply.



Figure A2. Front View, Test Vehicle as Delivered



Figure A3. Rear View, Test Vehicle as Delivered



Figure A4. Front View, Test Vehicle in Test Condition





Figure A5. Rear View, Test Vehicle in Test Condition

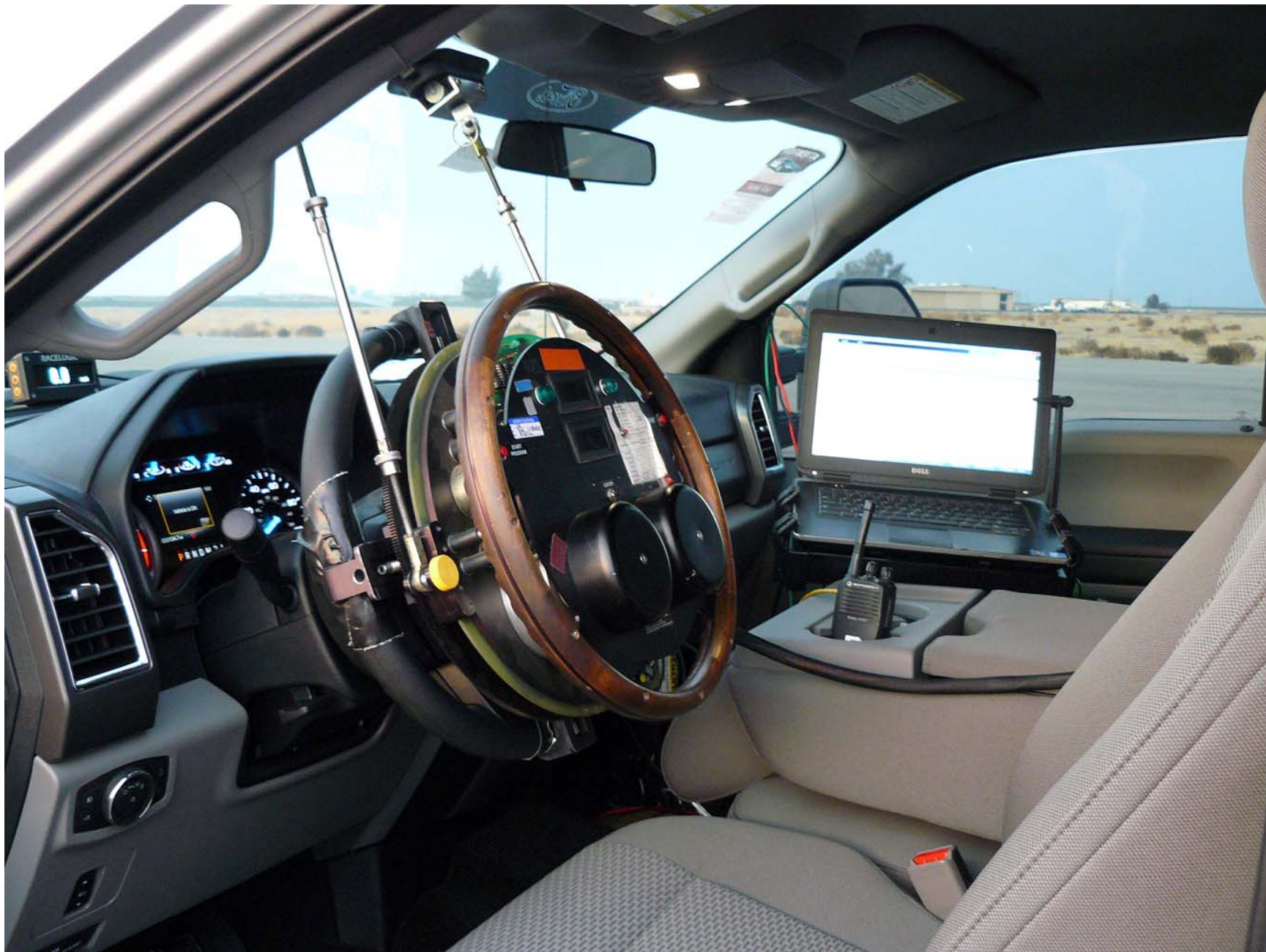

Figure A6. Instrumentation in Test Vehicle



Figure A7. Ballast Condition

APPENDIX B

Test Run Log

Vehicle: 2017 Ford F250 4WD

Driver: Stephan Rhim

Date: 11/23/2016

Run Number	Test Type	Speed (mph)	Handwheel Angle (deg)	Dir. of First Steer	2 Wheel Lift	Notes
1	Tire Warm-Up	35	100	Right	5P	Resulted in ay = 0.60g
2						
3						
4						2x SWA last cycle
5	Static	0	0			
6	Steady State	50	0			
7	Slowly Increasing Steer	50	80	Left	NA	ng
8	Slowly Increasing Steer	50	80	Left	NA	Resulted in ay = 0.56g
9	Slowly Increasing Steer	50	80	Left	NA	
10	Slowly Increasing Steer	50	80	Left	NA	
11	Slowly Increasing Steer	50	80	Right	NA	
12	Slowly Increasing Steer	50	80	Right	NA	
13	Slowly Increasing Steer	50	80	Right		
14	Fishhook	35	331	Left	No	6.5 Scalar
15	Fishhook	40	331	Left	No	
16	Fishhook	45	331	Left	No	
17	Fishhook	47.5	331	Left	No	
18	Fishhook	50	331	Left	No	
19	Fishhook	35	331	Right	No	
20	Fishhook	40	331	Right	No	
21	Fishhook	45	331	Right	No	
22	Fishhook	47.5	331	Right	No	
23	Fishhook	50	331	Right	No	
24	Fishhook	45	280	Right	No	5.5 Scalar

Vehicle: **2017 Ford F250 4WD**Driver: **Stephan Rhim**Date: **11/23/2016**

Run Number	Test Type	Speed (mph)	Handwheel Angle (deg)	Dir. of First Steer	2 Wheel Lift	Notes
25	Fishhook	47.5	280	Right	No	
26	Fishhook	50	280	Right	No	
27	Fishhook	45	280	Left	No	
28	Fishhook	47.5	280	Left	No	
29	Fishhook	50	280	Left	No	

APPENDIX C

Slowly Increasing Steer Test Worksheet

NCAP, 2017 Ford F250 4WD , Multi-Passenger Load, Test Date: 11/23/2016

SIS\_out\_v2

Run	Dir of Steer	Start Speed (mph)	End Speed (mph)	Speed Red. (%)	Index of ay @ 0.3g	HW Angle (deg) at 0.3g	ay (g) @ 0.3g index	6.5x HW Angle (deg)	Ramp Time (sec) at 6.5x	5.5x HW Angle (deg)	Ramp Time (sec) at 5.5x	R2	Zero Begin Index	Zero End Index
8	1	49.3	21	57.5	1272	-52.1	-0.306	-338.8	-0.4706	-286.7	-0.3982	0.9905	300	500
9	1	48.7	9.9	79.7	1281	-52.4	-0.309	-340.8	-0.4734	-288.4	-0.4006	0.9920	300	500
10	1	49.8	12.1	75.7	1271	-52.0	-0.291	-337.7	-0.469	-285.7	-0.3968	0.9881	300	500
11	0	50.6	8.8	82.5	1230	49.2	0.301	319.7	0.4440	270.5	0.3757	0.9908	300	500
12	0	49.2	14.8	69.9	1240	49.9	0.298	324.4	0.4506	274.5	0.3813	0.9899	300	500
13	0	48.2	19.7	59.2	1233	49.8	0.299	323.5	0.4494	273.8	0.3802	0.9833	300	500

Mean: 50.9 0.301 331 0.459 280 0.389

## Steering Controller Input Values

## Scalar 6.5 values:

Initial HW angle: 331 deg  
Initial time: 0.459 s  
Reversal HW angle: -331 deg  
Reversal time: 0.919 s

## Scalar 5.5 values:

Initial HW angle: 280 deg  
Initial time: 0.389 s  
Reversal HW angle: -280 deg  
Reversal time: 0.778 s



## APPENDIX D

### Time History Plots

## LIST OF FIGURES

	Page
D1. Vehicle Speed, Handwheel Angle, and Roll Angle Time History Plots for Default Test Series, L-R, 50 mph .....	D-3
D2. Steering Machine Operation Time History Plots for Default Test Series, L-R, 50 mph.....	D-4
D3. Yaw Rate, Roll Rate, and Lateral Acceleration Time History Plots for Default Test Series, L-R, 50 mph .....	D-5
D4. Pitch Rate and Longitudinal Acceleration Time History Plots for Default Test Series, L-R, 50 mph .....	D-6
D5. Vehicle Speed, Handwheel Angle, and Roll Angle Time History Plots for Default Test Series, R-L, 50 mph .....	D-7
D6. Steering Machine Operation Time History Plots for Default Test Series, R-L, 50 mph .....	D-8
D7. Yaw Rate, Roll Rate, and Lateral Acceleration Time History Plots for Default Test Series, R-L, 50 mph .....	D-9
D8. Pitch Rate and Longitudinal Acceleration Time History Plots for Default Test Series, R-L, 50 mph .....	D-10
D9. Vehicle Speed, Handwheel Angle, and Roll Angle Time History Plots for Supplemental 2 Test Series, L-R, 50 mph.....	D-11
D10. Steering Machine Operation Time History Plots for Supplemental 2 Test Series, L-R, 50 mph .....	D-12
D11. Yaw Rate, Roll Rate, and Lateral Acceleration Time History Plots for Supplemental 2 Test Series, L-R, 50 mph .....	D-13
D12. Pitch Rate and Longitudinal Acceleration Time History Plots for Supplemental 2 Test Series, L-R, 50 mph .....	D-14
D13. Vehicle Speed, Handwheel Angle, and Roll Angle Time History Plots for Supplemental 2 Test Series, R-L, 50 mph.....	D-15
D14. Steering Machine Operation Time History Plots for Supplemental 2 Test Series, R-L, 50 mph .....	D-16
D15. Yaw Rate, Roll Rate, and Lateral Acceleration Time History Plots for Supplemental 2 Test Series, R-L, 50 mph .....	D-17
D16. Pitch Rate and Longitudinal Acceleration Time History Plots for Supplemental 2 Test Series, R-L, 50 mph .....	D-18

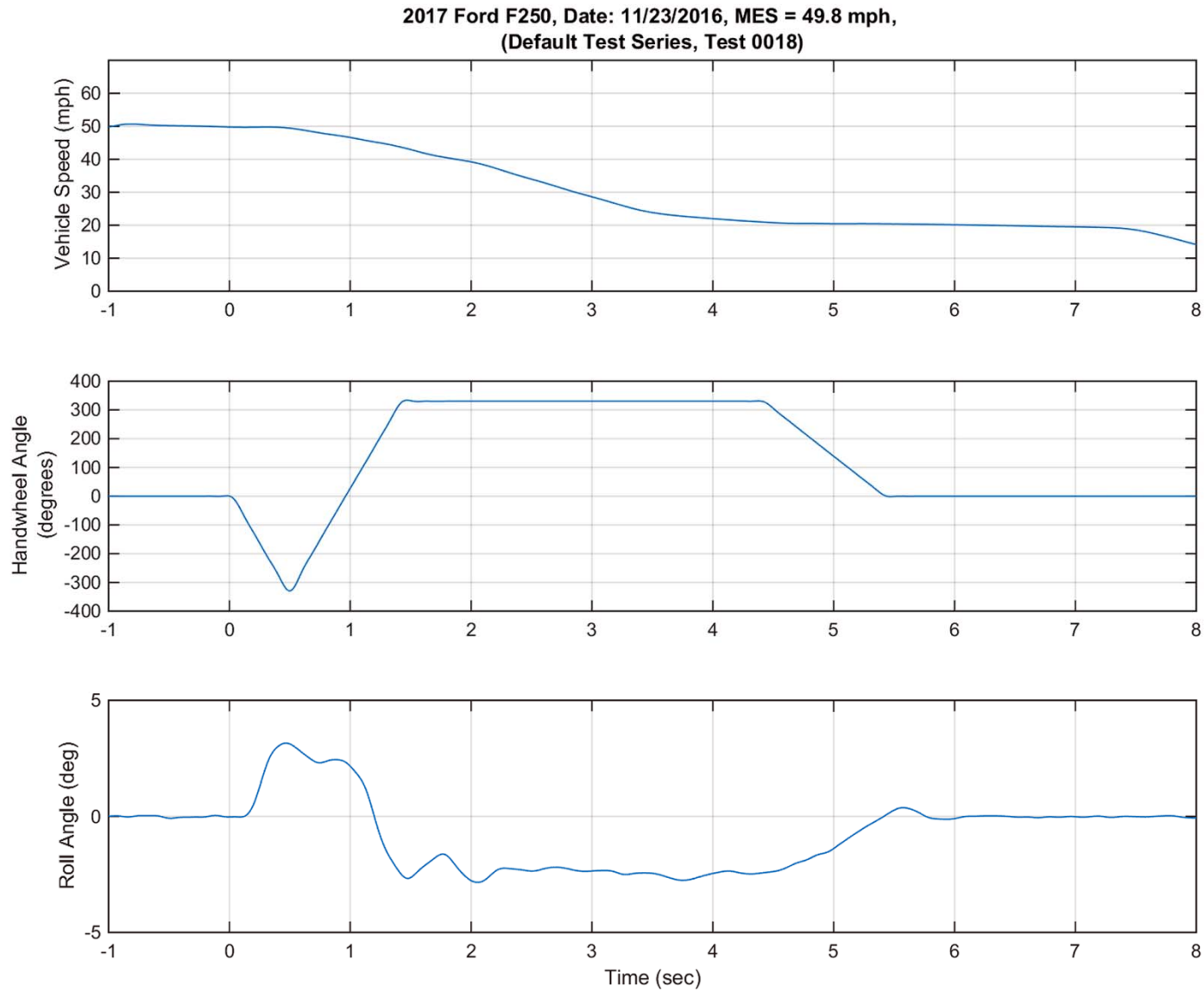

Figure D1. Vehicle Speed, Handwheel Angle, and Roll Angle Time History Plots for Default Test Series, L-R, 50 mph

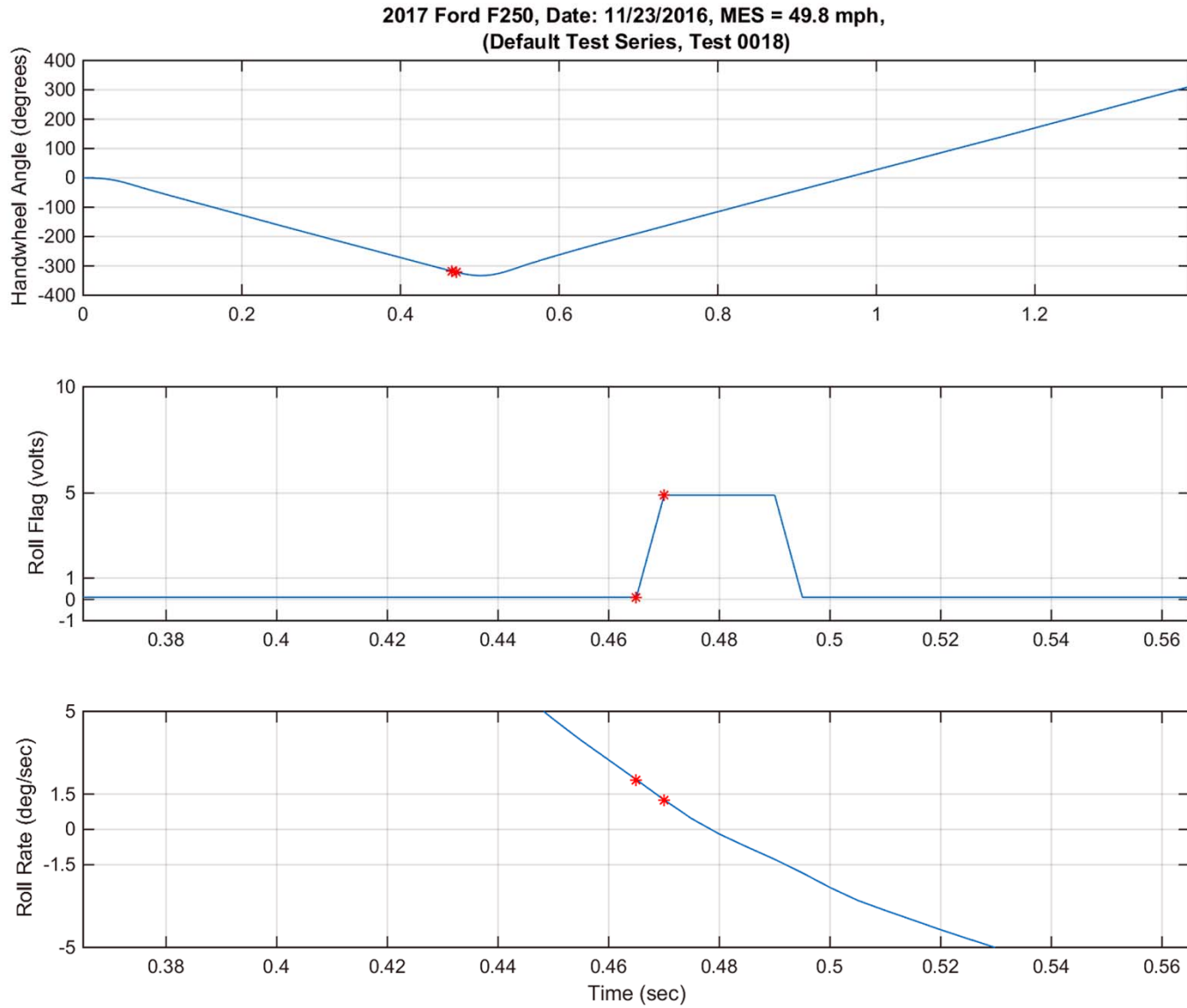

Figure D2. Steering Machine Operation Time History Plots for Default Test Series, L-R, 50 mph

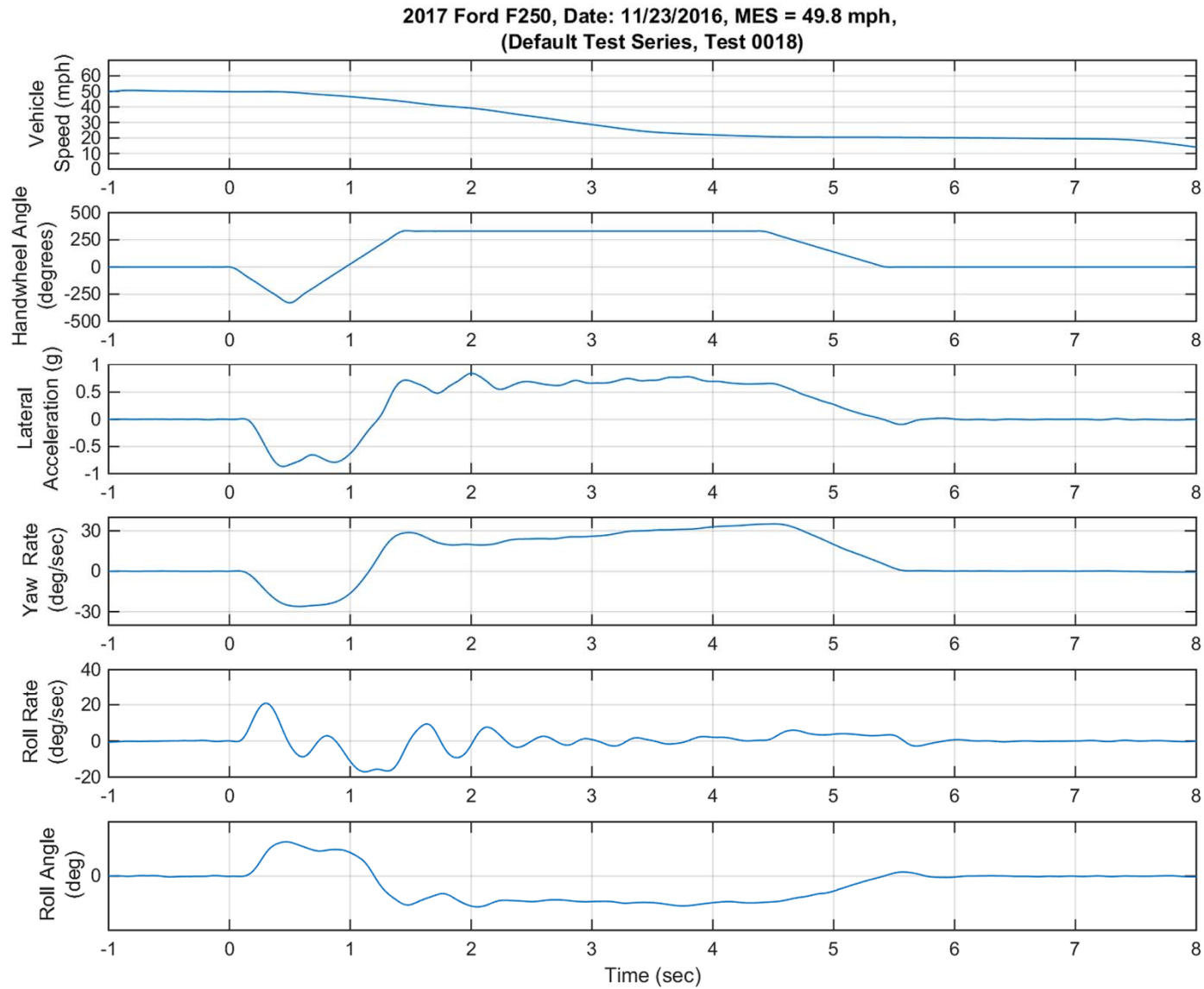

Figure D3. Yaw Rate, Roll Rate, and Lateral Acceleration Time History Plots For Default Test Series, L-R, 50 mph

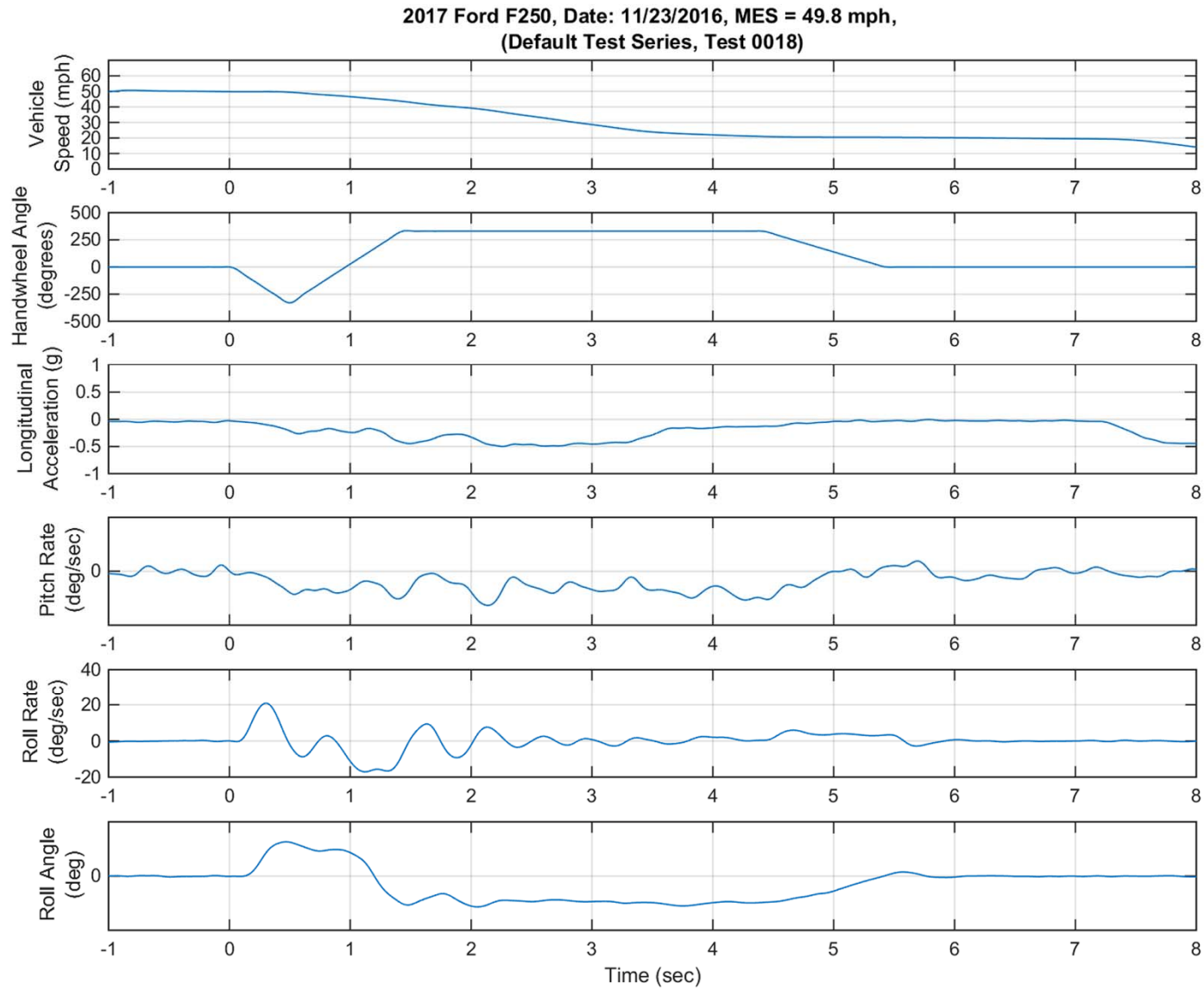

Figure D4. Pitch Rate and Longitudinal Acceleration Time History Plots for Default Test Series, L-R, 50 mph

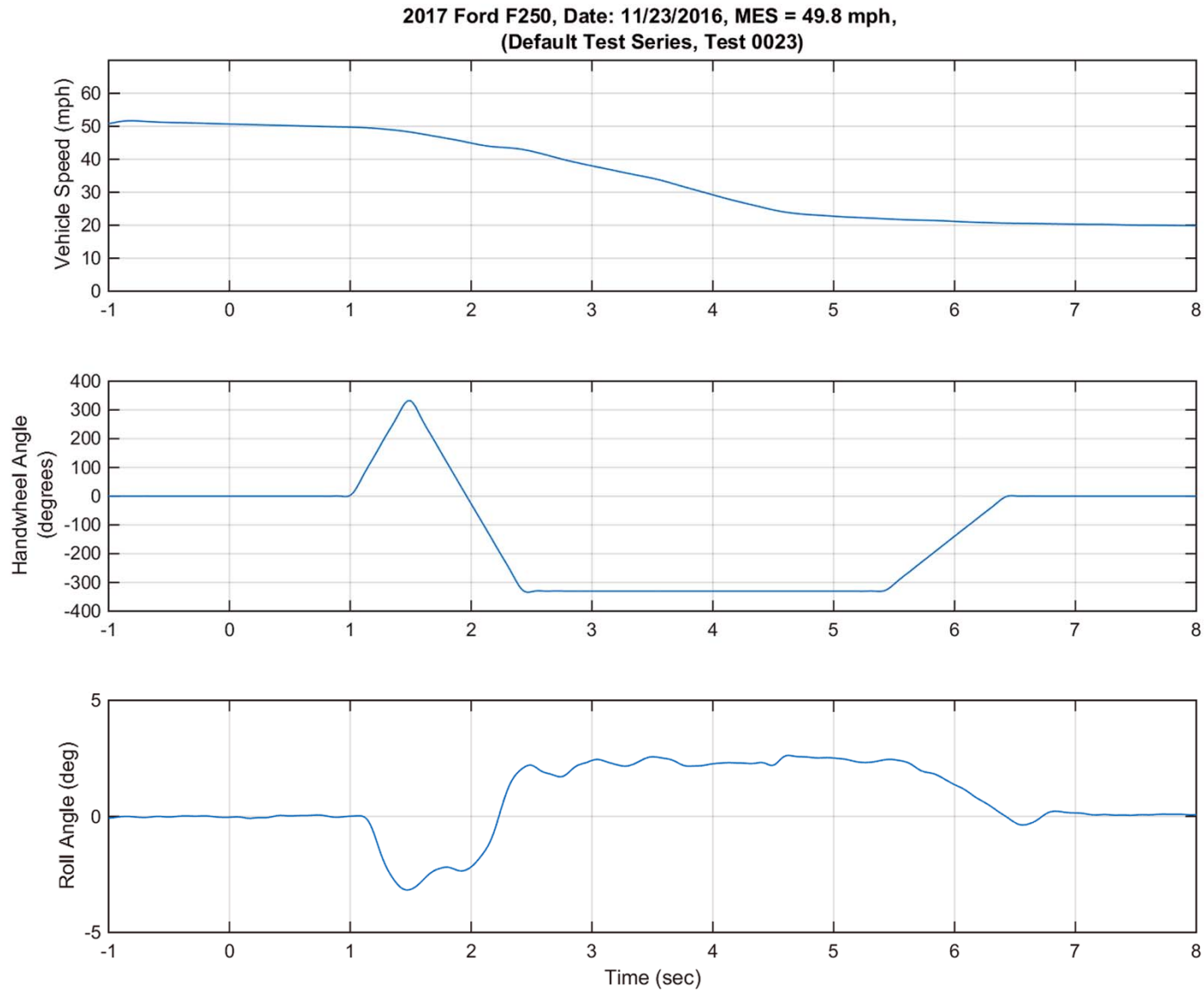

Figure D5. Vehicle Speed, Handwheel Angle, and Roll Angle Time History Plots for Default Test Series, R-L, 50 mph

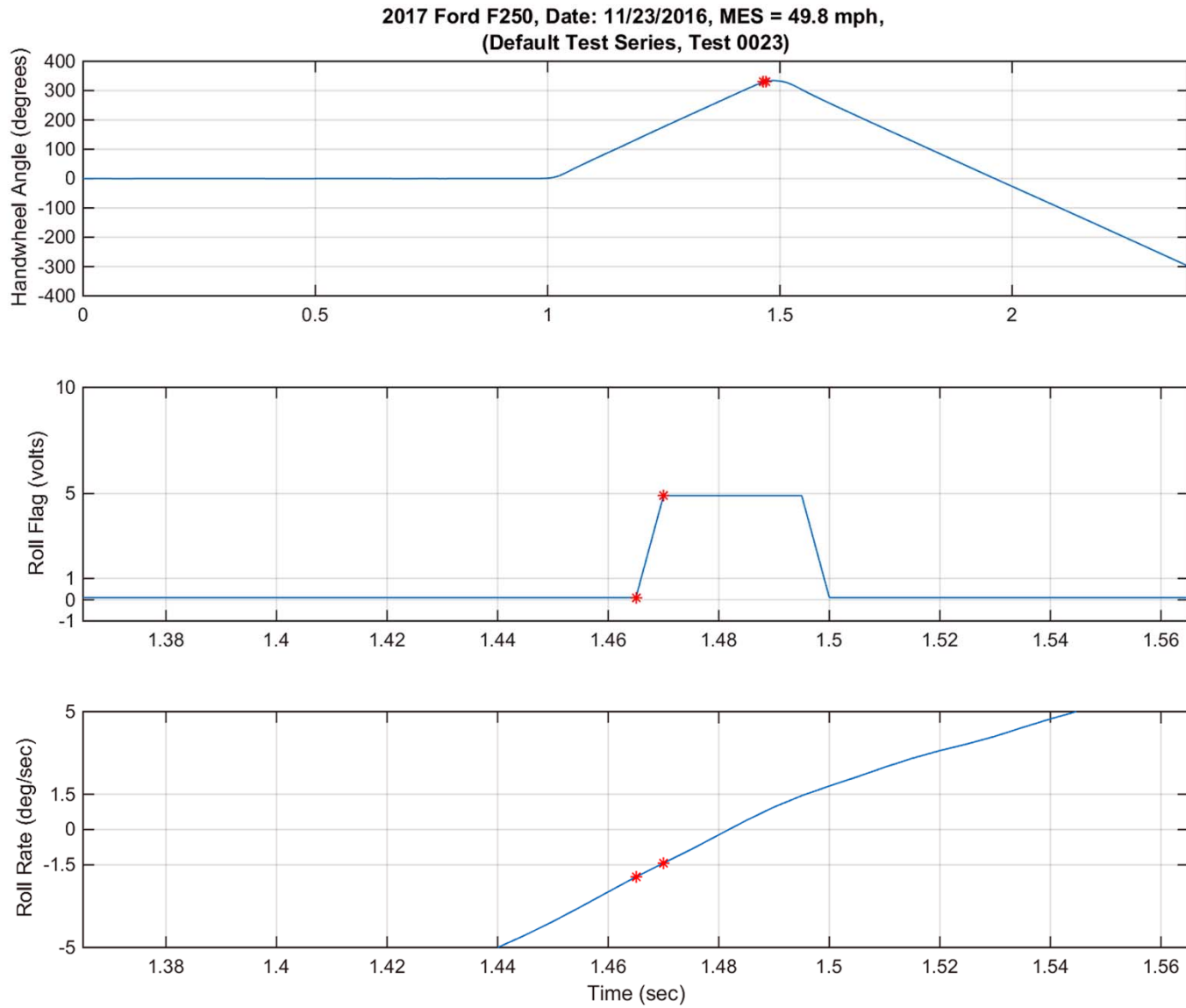

Figure D6. Steering Machine Operation Time History Plots for Default Test Series, R-L, 50 mph



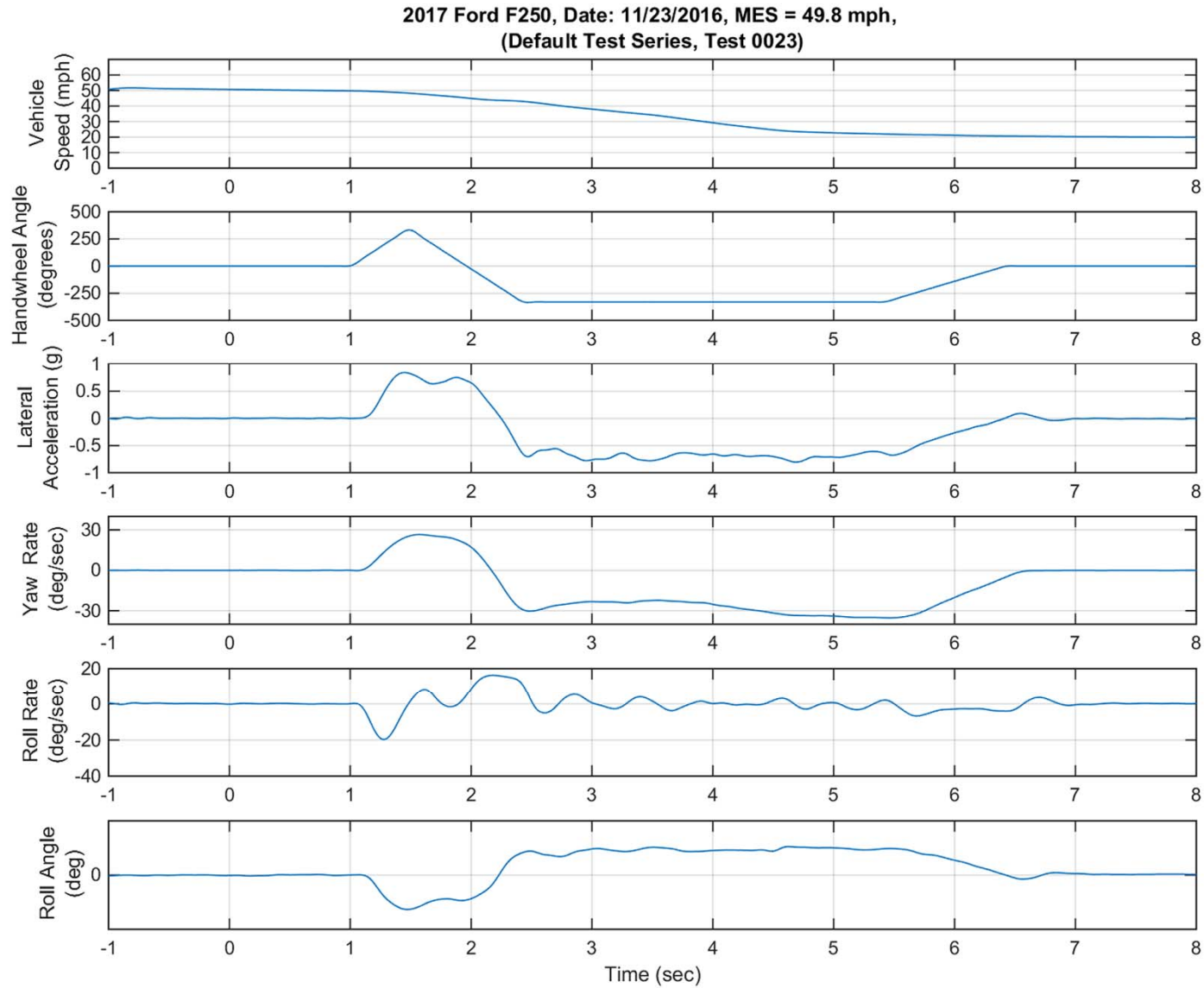

Figure D7. Yaw Rate, Roll Rate, and Lateral Acceleration Time History Plots for Default Test Series, R-L, 50 mph

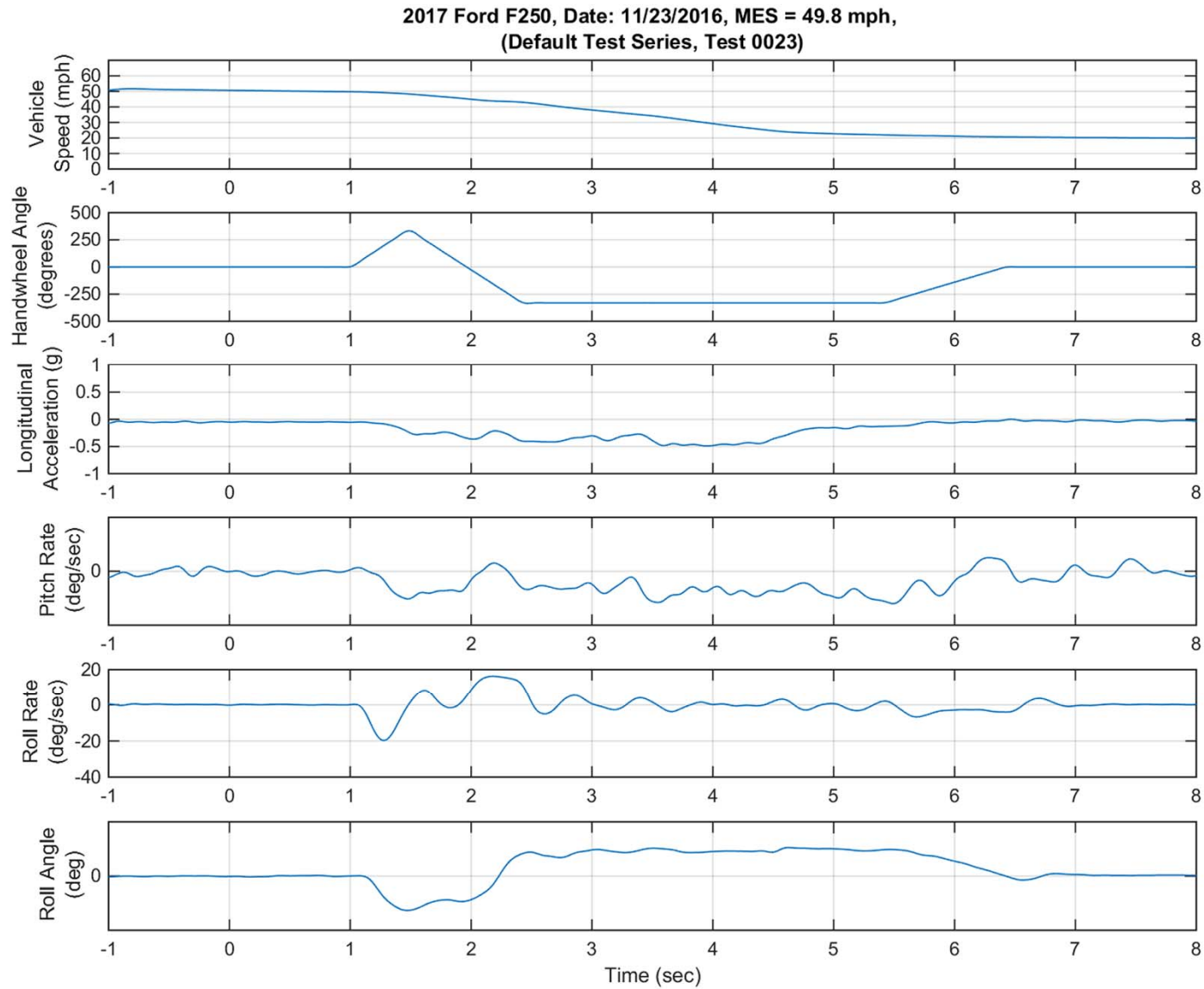

Figure D8. Pitch Rate and Longitudinal Acceleration Time History Plots or Default Test Series, R-L, 50 mph

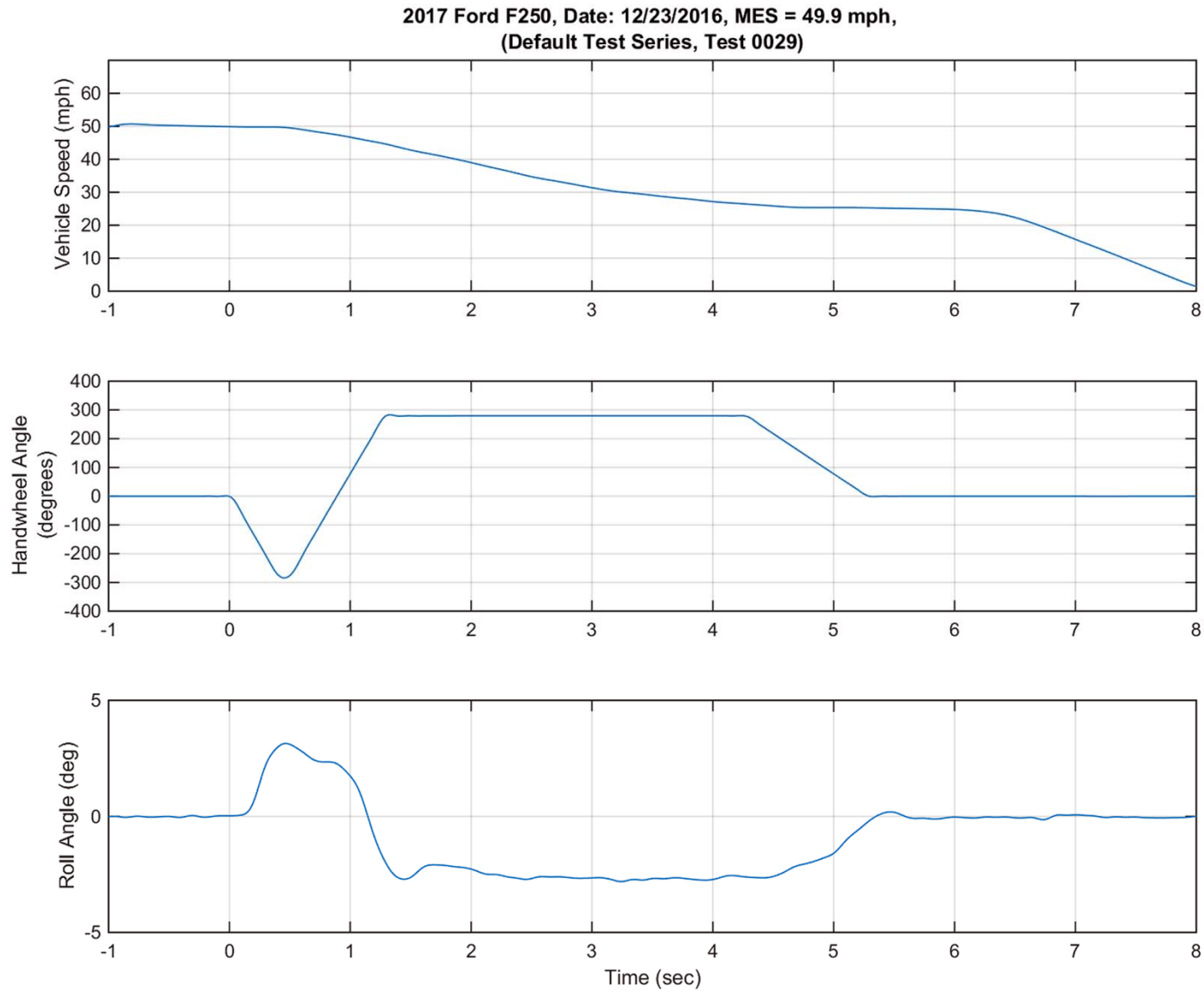

Figure D9. Vehicle Speed, Handwheel Angle, and Roll Angle Time History Plots for Supplemental 2 Test Series, L-R, 50 mph

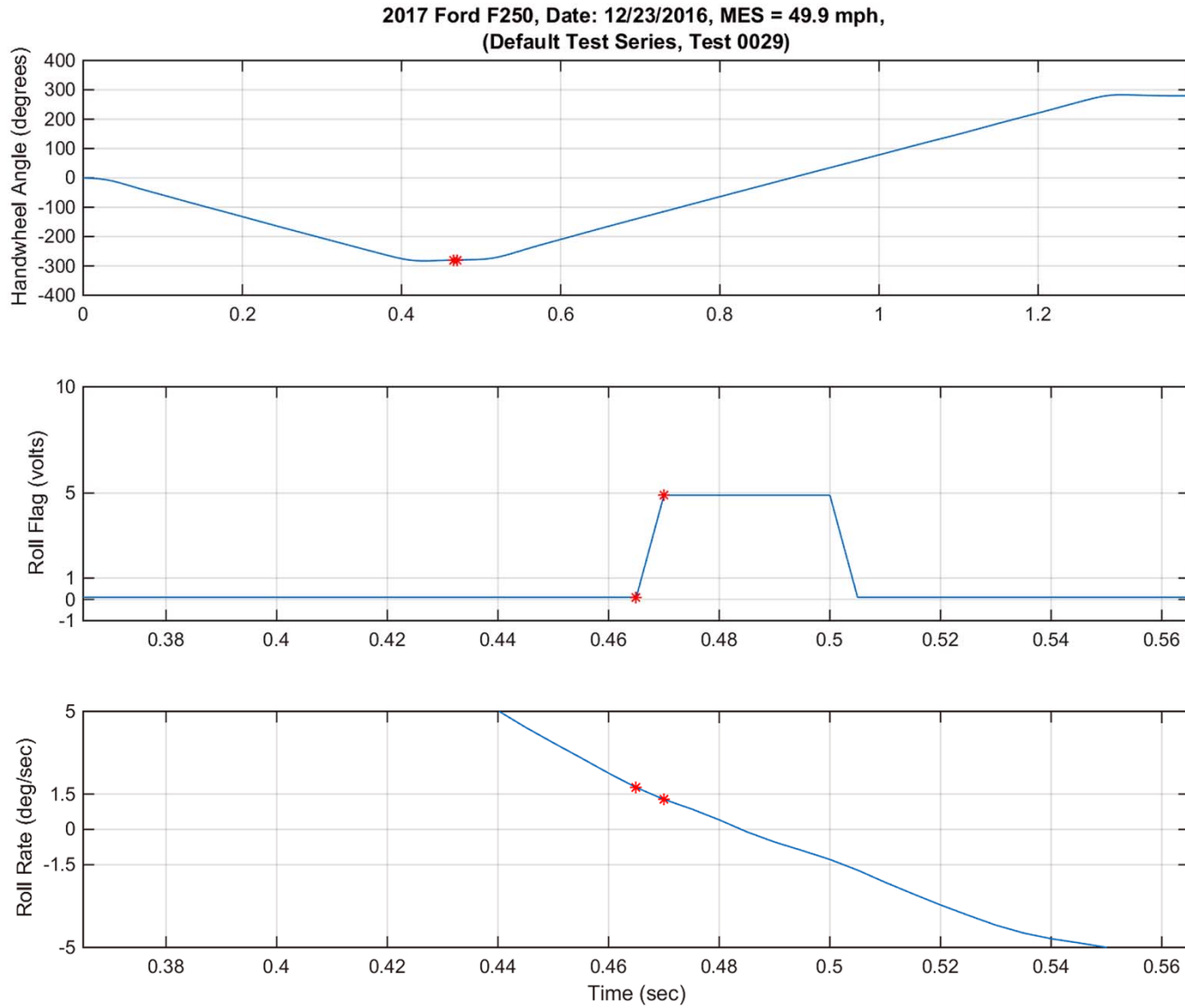

Figure D10. Steering Machine Operation Time History Plots for Supplemental 2 Test Series, L-R, 50 mph

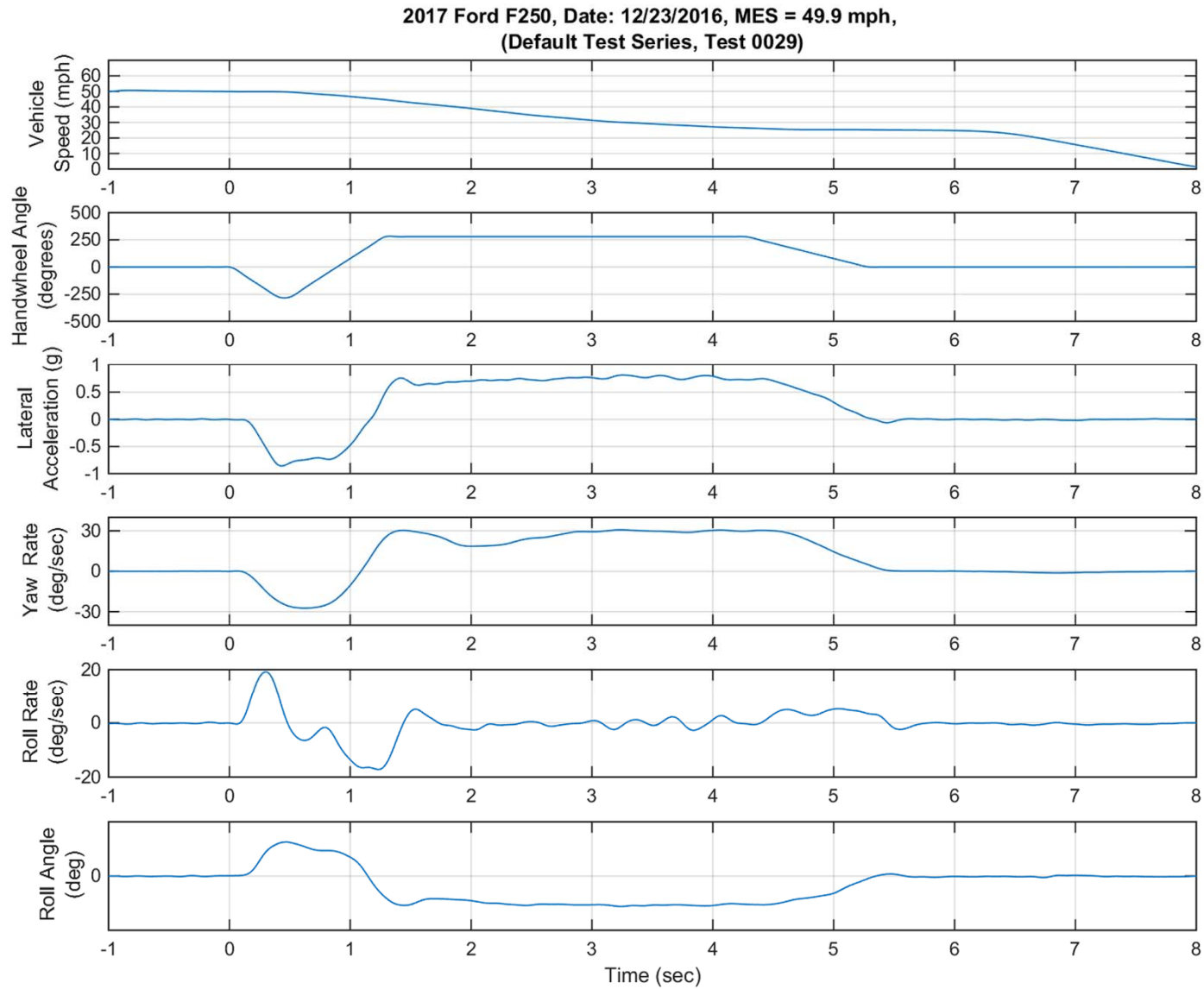

Figure D11. Yaw Rate, Roll Rate, and Lateral Acceleration Time History Plots for Supplemental 2 Test Series, L-R, 50 mph

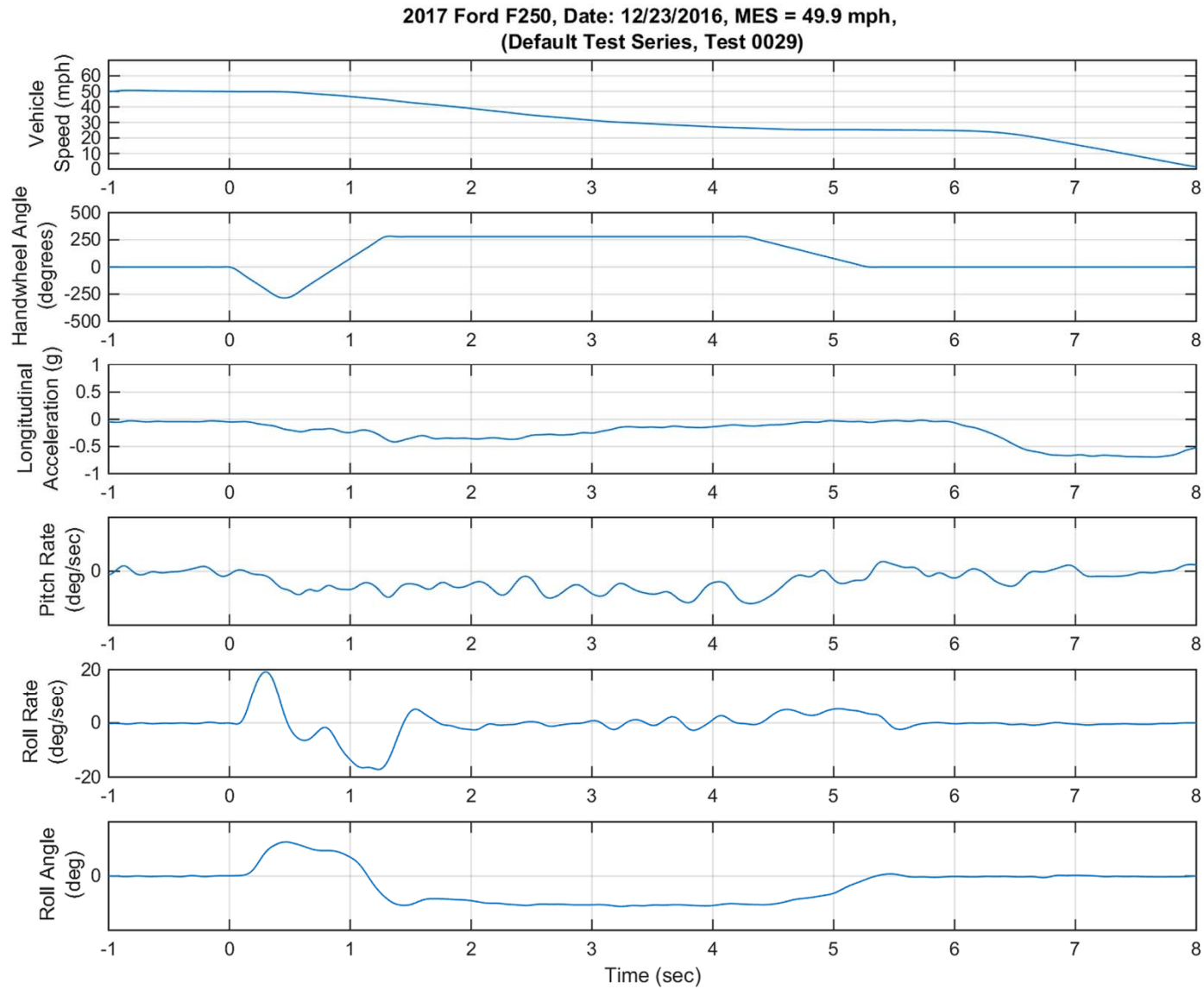

Figure D12. Pitch Rate and Longitudinal Acceleration Time History Plots for Supplemental 2 Test Series, L-R, 50 mph

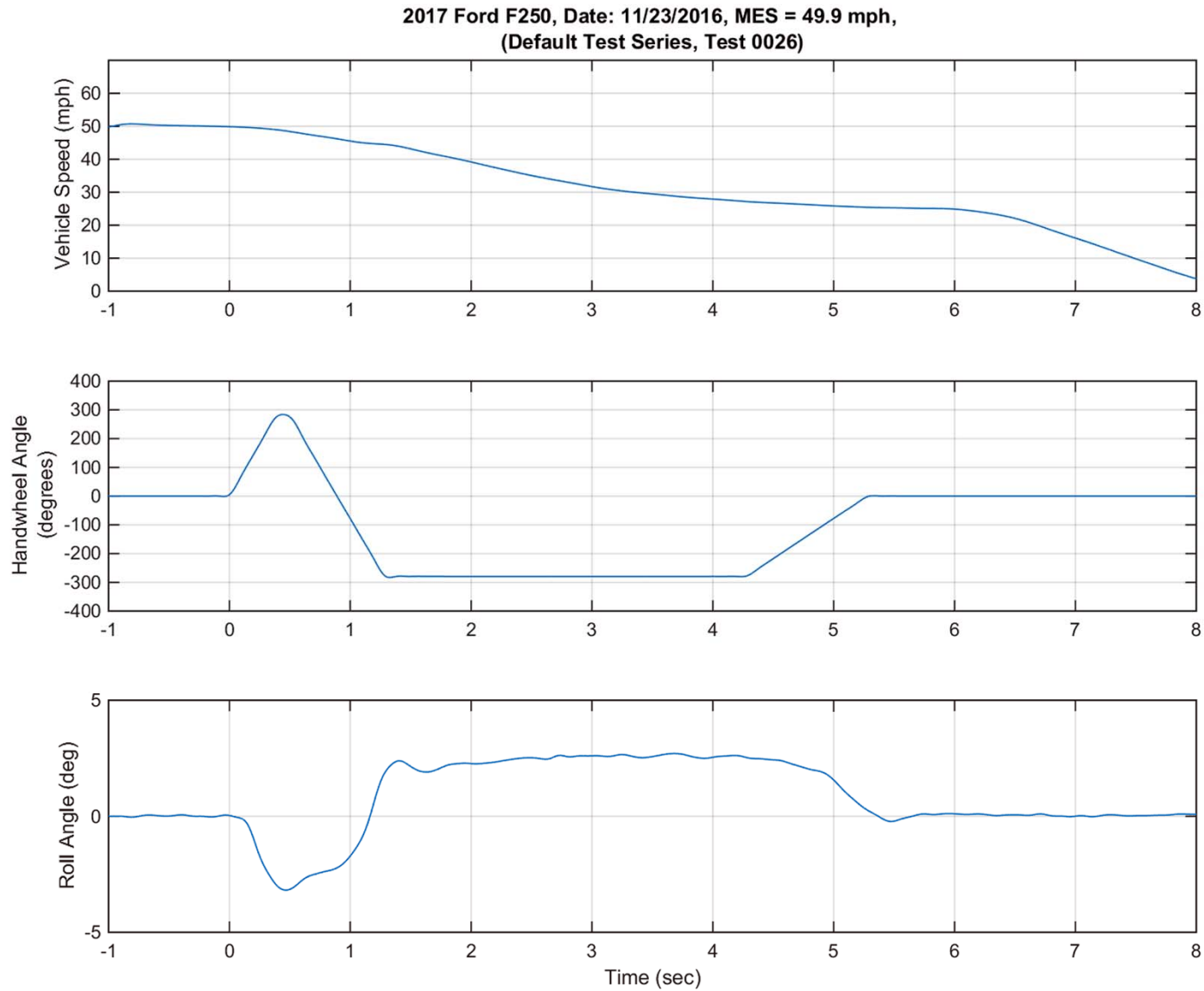

Figure D13. Vehicle Speed, Handwheel Angle, and Roll Angle Time History Plots for Supplemental 2 Test Series, R-L, 50 mph

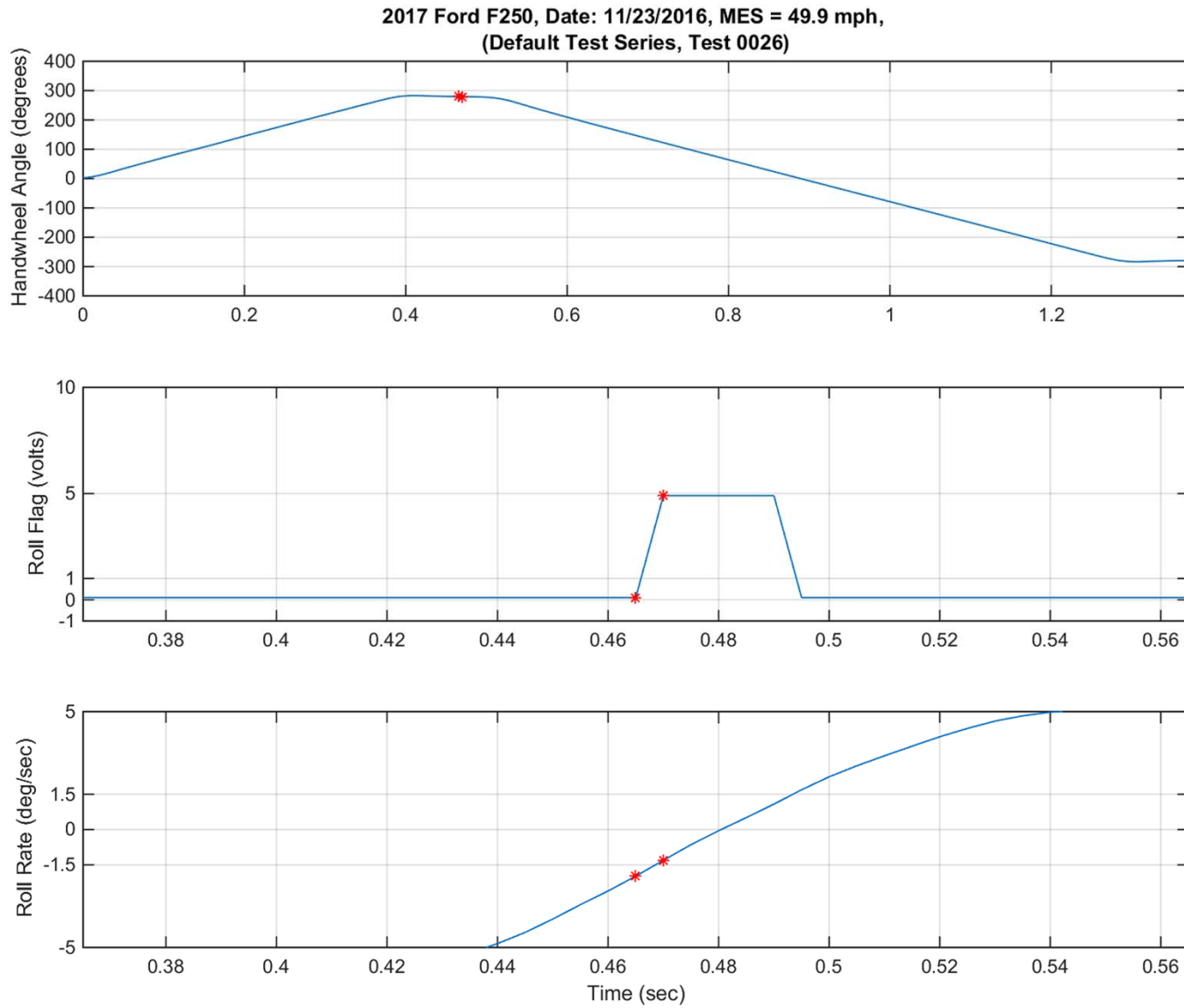

Figure D14. Steering Machine Operation Time History Plots for Supplemental 2 Test Series, R-L, 50 mph



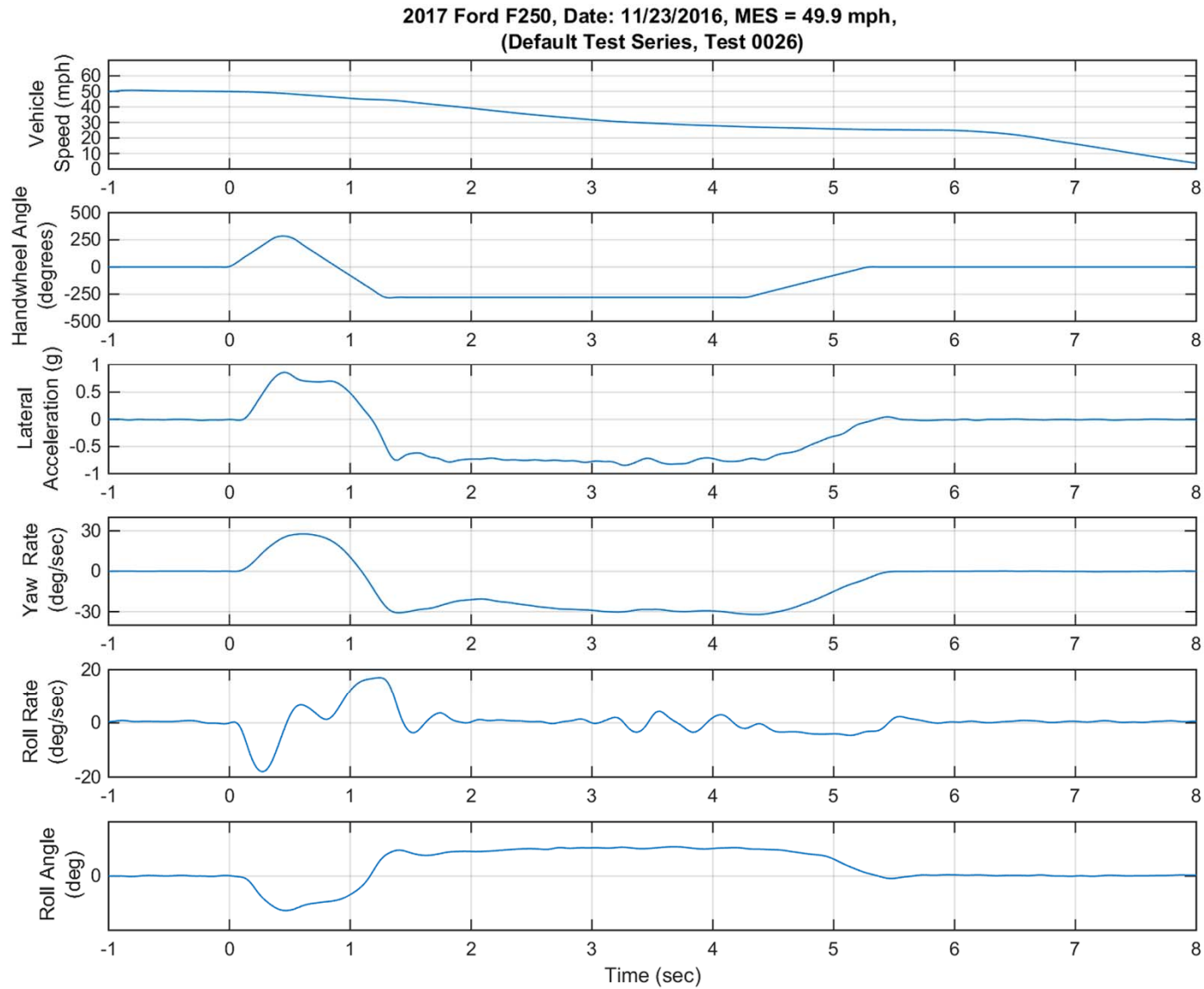

Figure D15. Yaw Rate, Roll Rate, and Lateral Acceleration Time History Plots for Supplemental 2 Test Series, R-L, 50 mph

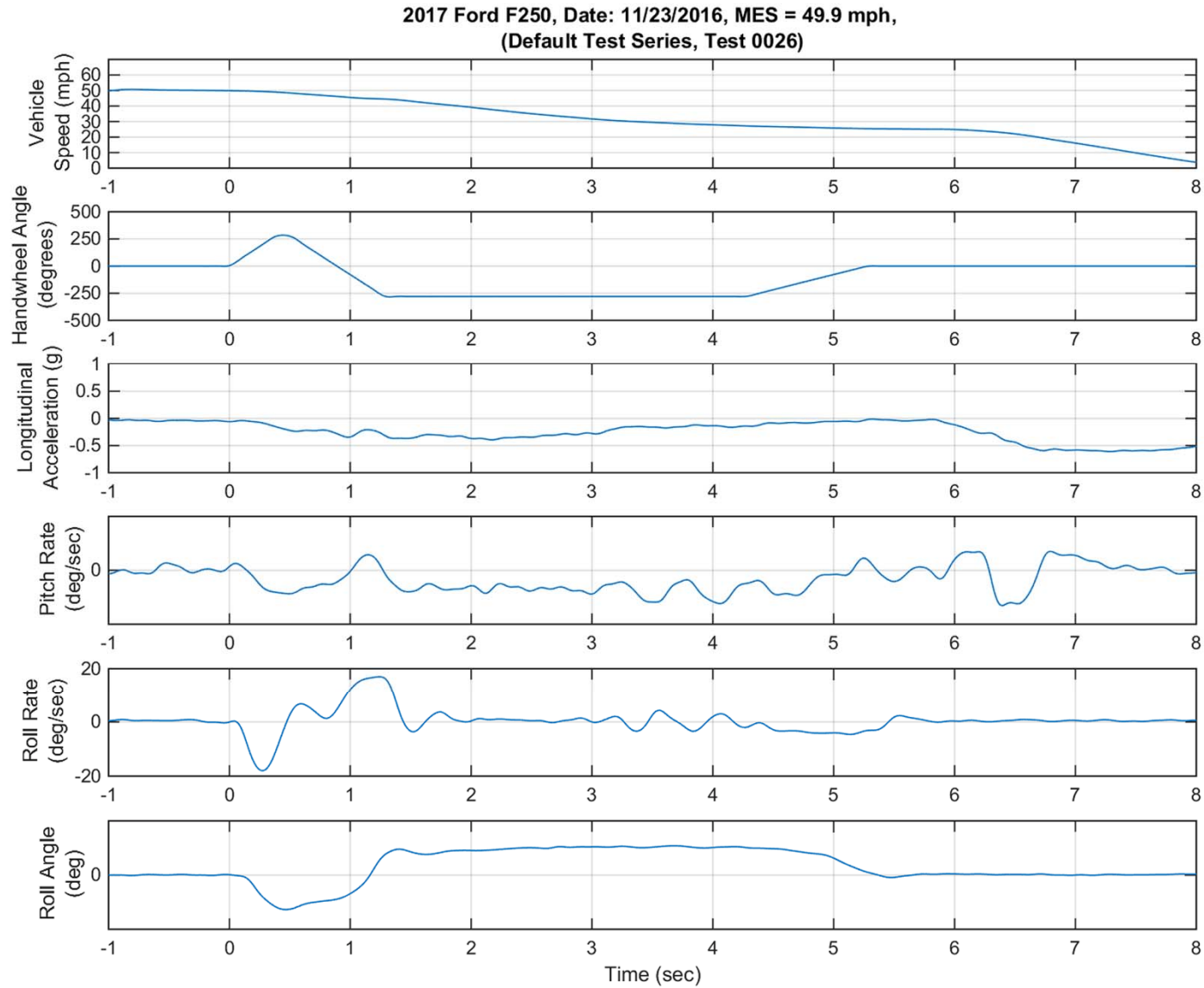

Figure D16. Pitch Rate and Longitudinal Acceleration Time History Plots for Supplemental 2 Test Series, R-L, 50 mph