

**NEW CAR ASSESSMENT PROGRAM (NCAP)
DYNAMIC ROLLOVER RESISTANCE TEST**

Honda Manufacturing of Alabama

2017 Honda Ridgeline AWD

TEST NUMBER: 17-06

Final Report
17 January 2017



Prepared by:

Dynamic Research, Inc
355 Van Ness Ave. #200
Torrance, CA 90501

Prepared for:

National Highway Traffic Safety Administration
Office of Crash Avoidance Standards
1200 New Jersey Avenue S.E.
Washington, DC 20590

The United States Government assumes no liability for the contents of this report or use thereof. If trade or manufacturers' names or products are mentioned, it is only because they are considered essential to the object of the publication and should not be construed as an endorsement. The United States Government does not endorse products or manufacturers.

Dynamic Research, Inc. does not endorse or certify products of manufacturers. The manufacturer's name appears solely to identify the test article. Dynamic Research, Inc. assumes no liability for the report or use thereof. It is responsible for the facts and the accuracy of the data presented herein. This report does not constitute a standard, specification, or regulation.

Report Prepared by:



John Lenkeit, Program Manager

Date: 17 January 2017

Report Approved by:



Peter Broen, Principal Engineer

Date: 17 January 2017

1. Report No. 17-06	2. Government Accession No.	3. Recipient's Catalog No.	
4. Title and Subtitle NCAP Dynamic Rollover Resistance Maneuver (Fishhook) Test of a 2017 Honda Ridgeline AWD Pickup		5. Report Date 17 January 2017	6. Performing Organization Code DRI
		8. Performing Organization Report No. DRI- TM-16-202	
7. Author(s) John Lenkeit, Program Manager Peter Broen, Project Engineer		10. Work Unit No. (TRAIS)	
9. Performing Organization Name and Address Dynamic Research, Inc. 355 Van Ness Ave. #200 Torrance, CA 90501		11. Contract or Grant No. DTNH22-14-D-00332	
		13. Type of Report and Period Covered Final Report November 2016 to December 2016	
12. Sponsoring Agency Name and Address National Highway Traffic Safety Administration Office of Crash Avoidance Standards 1200 New Jersey Avenue S.E. Washington, DC 20590		14. Sponsoring Agency Code	
		15. Supplemental Notes	
16. Abstract An NCAP Dynamic Rollover Maneuver (Fishhook) Test was conducted on a 2017 Honda Ridgeline AWD at Dynamic Research, Inc. on November 18, 2016. The vehicle did not experience two-wheel lift. The vehicle's steering angle at 0.3g lateral acceleration at 50 mph was 35.1 degrees.			
17. Key Words NCAP Rollover Resistance Ratings Fishhook Test		18. Distribution Statement Copies of this report are available from: National Highway Traffic Safety Admin. Office of Crash Avoidance Standards 1200 New Jersey Ave., S.E. Washington, DC 20590	
19. Security Classif. (of this report) Unclassified	20. Security Classif. (of this page) Unclassified	21. Number of Pages 50	22. Price

TABLE OF CONTENTS

	Page
I. INTRODUCTION.....	1
II. VEHICLE PREPARATION	2
A. Test Vehicle	2
B. Tires	2
C. Vehicle Loading.....	2
D. Steering Controller	5
E. Instrumentation and Data Collection	5
F. Other Vehicle Preparation	5
III. TEST PROCEDURES.....	8
A. Test Procedure Overview.....	8
B. Test Conditions	9
IV. RESULTS.....	12
APPENDIX A Photographs	A-1
APPENDIX B Test Run Log.....	B-1
APPENDIX C Slowly Increasing Steer Test Worksheet.....	C-1
APPENDIX D Time History Plots	D-1

LIST OF FIGURES

	Page
1. Nominal Position of Video Cameras for Fishhook Tests	8
2. DRI-Minter Vehicle Dynamics Area	12

LIST OF TABLES

	Page
1. Test Vehicle Data	3
2. Tire Information	4
3. Vehicle Loading	4
4. Sensors	7
5. Surface Friction	10
6. Handwheel Angles	11
7. Weather Conditions	11

Section I
INTRODUCTION

Beginning with the 2006 fiscal year, the National Highway Traffic Safety Administration (NHTSA) has engaged Dynamic Research, Inc. (DRI) of Torrance, CA to conduct dynamic rollover testing and gather data from that testing as part of NHTSA's New Car Assessment Program (NCAP).

The purpose of the testing reported herein was to determine if a typical 2017 Honda Ridgeline AWD would experience tip-up, defined as simultaneous two-wheel lift of two inches or more at an entry speed of 50 mph or less in the Fishhook Procedure developed by NHTSA. This procedure may be found at www.regulations.gov, docket item NHTSA-2006-26555-0136.

The testing reported herein was accomplished under contract DTNH22-14-D-00332. The task order is entitled, "New Car Assessment Program (NCAP) Non-Destructive Vehicle Testing and Data Gathering."

Section II VEHICLE PREPARATION

A. TEST VEHICLE

The test vehicle was new or in as-new condition, meaning the vehicle had been driven no more than 500 miles prior to the start of dynamic rollover testing. It was acquired through a commercial rental/leasing company. Details of the test vehicle are given in Table 1.

B. TIRES

All tires used were new, and of the same make, model, size, and DOT specification of those installed on the vehicle when purchased new. Tire inflation pressures were in accordance with the recommendations indicated on each vehicle's identification placard. To reduce the possibility of tire debanding during Fishhook testing, an appropriately sized inner tube was installed in each tire. To further reduce the possibility of tire debanding, the tires were mounted to the rims without the use of tire mounting lubricant. Tire specifications are listed in Table 2.

C. VEHICLE LOADING

The multi-passenger load, described in the Fishhook Procedure, was used for all tests. The load and positioning of the load in the vehicle are listed in Table 3.

In addition to water dummies, the loading included instrumentation, a steering machine, and outriggers. Test vehicle bumper assemblies were removed for outrigger installation. The reduction in vehicle weight due to the removal of the bumpers was offset by the additional weight of the outriggers and their mounting system. The outrigger system typically outweighs the bumper assemblies.

Table 1. Test Vehicle Data

General Data					
Model year, make, model	2017 Honda Ridgeline AWD				
VIN	5FPYK3F77HB01xxxx				
Body style	Pickup				
Number of doors	4				
Trim level	AWD RTL-E				
Seating positions	Front:	2 nd row	3 rd row	4 th row	5 th row
	2	3			
Electronic stability control	Yes				
4-Wheel ABS (Yes/No)	Yes				
Power steering (Yes/No)	Yes				
Major optional equipment					
Odometer at start of testing	22 miles				
Drivetrain					
Engine cylinder arrangement	V-6				
Engine displacement	3.5 L				
Transmission type	Automatic				
Drive arrangement	AWD				
Chassis					
Track width	F: 66.2 in (1681.5 mm) , R: 66.2 in (1681.5 mm)				
Wheelbase	125.2 in (3180.1 mm)				
Curb weight	4520 lb (2050.2 kg)				
Certification Data from Vehicle's Label					
Vehicle manufactured by	Honda Manufacturing of Alabama				
Date of manufacture	10/16				
GVWR	6019 lb (2730 kg)				
GAWR Front	3131 lb (1420 kg)				
GAWR Rear	3219 lb (1460 kg)				

Table 2. Tire Information

Tire Manufacturer	Firestone
Tire Model	Destination LT2
Tire Size	Front: 245/60R18 Rear: 245/60R18
Load rating	Front: 105 Rear: 105
Speed rating	Front: H Rear: H
Treadwear grade	Front: 520 Rear: 520
Traction grade	Front: A Rear: A
Temperature grade	Front: A Rear: A
Location of "Recommended Tire Pressure" label	Driver's door jamb
Recommended cold tire pressure	Front: 35 psi, (240 kPa) Rear: 35 psi, (245 kPa)
First 8 digits of DOT code	Front: 8X83 DE3 Rear: 8X83 DE3

Table 3. Vehicle Loading

Water dummy and other loading	3 water dummies in second row
Water dummy weight	175 lb (79.4 kg)
Fuel level	Full
Weight as Tested	
Left front	1571 lb (712.6 kg)
Right front	1500 lb (680.4 kg)
Left rear	1251 lb (567.4 kg)
Right rear	1210 lb (548.8 kg)

D. STEERING CONTROLLER

A programmable steering machine was installed which generates handwheel steering inputs for all test maneuvers. The machine provides at least 35 lb-ft of torque at a handwheel rate of 720 deg/sec, is capable of actuating the vehicle's steering system through its full range, and accepts angular rate sensor feedback input for roll rate-induced steering reversals.

E. INSTRUMENTATION AND DATA COLLECTION

The test vehicle was instrumented with an angle encoder, located in the steering controller; a 3-axis inertial measurement unit to measure roll, pitch, and yaw rates, and longitudinal, lateral, and vertical acceleration; two ultrasonic distance measuring sensors to measure vehicle roll angle; and a radar speed sensor to measure vehicle speed. The brake light circuit was monitored to verify that there was no brake pedal application during any test.

A list of the sensors is given in Table 4. A 3B signal conditioning and power rack was used to provide any necessary sensor power, excitation, gain, and offset. Two pole Butterworth anti-alias filters were used for all analog data channels, using a corner frequency of 20 Hz. Data were collected at 200 samples/sec, using a Measurement Computing Corp. PCI-DAS6402/16 A/D board.

Two video cameras were used to record the Fishhook runs. They were positioned nominally as shown in Figure 1. The recorded videotapes were reviewed after the Fishhook runs to check for any two wheel lift. If any two wheel lift was observed, eight infrared distance measuring sensors for measurement of wheel lift (two sensors at each wheel) were then mounted for use in subsequent confirmation Fishhook tests.

F. OTHER VEHICLE PREPARATION

In addition to installation and preparation discussed above, the test vehicle was prepared as follows:

- Front and rear bumpers were removed
- Outrigger mounts were installed in the bumper locations and titanium outriggers were fastened to these mounts
- A five point safety harness was installed.
- Airbags were removed or otherwise disabled

Photographs of the vehicle tested are given in Appendix A.

Table 4. Sensors

Data Measured	Type	Range	Manufacturer	Model Number
Handwheel angle	Encoder	Infinite	Heitz Automotive Testing, Inc.	Angle encoder integral with steering controller
Brake pedal actuation	Tape Switch	On/Off	Vericom Computers	VC3000
Longitudinal, lateral, and vertical acceleration	Multi-axis inertial sensing system	± 2 g	BEI Technologies, Inc., Systron Donner Inertial Division	MP-1
Roll, pitch, and yaw rate		± 100 deg/s		
Left and right side vehicle ride height (to measure roll angle)	Ultrasonic distance measuring system	50 – 400 mm	Texense	RH550-400
Vehicle speed	Radar speed sensor	0 - 100 mph	Racelogic VBox	VBSS100-V3
Wheel lift (via resolution of two measured distances spaced a known distance apart), used for confirmation tests only	Analog displacement measuring system (Infrared; 880 mm)	13.8 - 33.5 in	Wenglor Sensors, Ltd.	HT 66MGV80

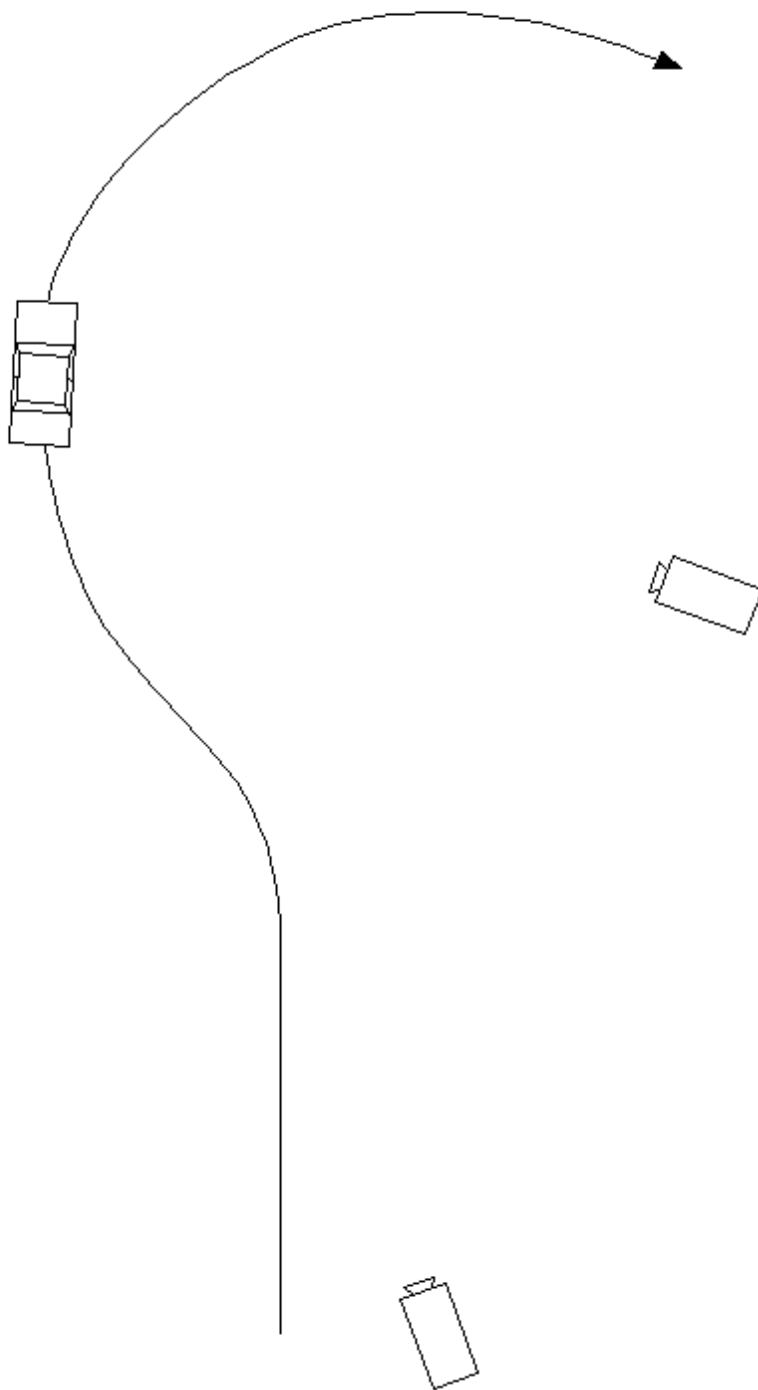

Figure 1. Nominal Position of Video Cameras for Fishhook Tests

Section III TEST PROCEDURES

This section includes a general overview of the test procedures and details of the particular test.

A. TEST PROCEDURE OVERVIEW

This test was conducted in accordance with NHTSA's NCAP Rollover Resistance Test Procedure (Fishhook) as described in the Federal Register (68 FR 59250). Detailed descriptions of the test procedure, pass/fail criteria, and data acquisition specifications may be found at docket NHTSA-2001-9663.

There are two major components of the test procedure, the Slowly Increasing Steer (SIS) pre-test and the Fishhook test.

The Slowly Increasing Steer (SIS) maneuver was used to characterize the steady state lateral dynamics of each vehicle, and is based on the "Constant Speed, Variable Steer" test defined in SAE J266. The maneuver is used to determine the handwheel angle that produces a lateral acceleration of 0.3 g at 50 mph. This handwheel angle is then used to determine the magnitude of steering to be used for the NHTSA Fishhook maneuver.

SIS tests were performed at a constant speed of 50 mph. Handwheel angle was input at a rate of 13.5 deg/sec, from 0 to an angle that provided at least 0.55 g. Three tests were conducted in each direction, and the data for the six runs were averaged to obtain the handwheel angle that produced 0.3 g at 50 mph.

The Fishhook test is a programmed steering maneuver that is implemented via the steering controller. The vehicle was initially steered in one direction and then the steering was reversed. The timing, magnitude and rate of the steering were prescribed by the Fishhook Procedure.

To begin the maneuver, the vehicle was driven in a straight line at a speed slightly greater than the desired entrance speed. The driver then released the throttle. When the vehicle was at the target speed, the steering controller automatically initiated the steering maneuver. Following completion of the steering reversal the handwheel position was maintained for three seconds, and then returned to zero angle in 1 second.

The tests were conducted in both left-right and right-left directions. The “Default” test series used a handwheel angle equal to 6.5 times the handwheel angle that produced 0.3 g at 50 mph in the SIS tests, and initial vehicle speeds beginning at 35 mph and concluding up to 50 mph (if no two-wheel lift occurs). Supplemental tests were also done, as specified in the Fishhook Procedure.

B. TEST CONDITIONS

1. Test Surface

The tests were conducted on the Vehicle Dynamics Area at DRI’s Minter Field facility, located near Bakersfield, California, on 11/18/2016. The VDA has a smooth, flat (slope less than 0.5% throughout) asphaltic concrete surface. Its dimensions are as shown in Figure 2. It was built in the spring of 2005.

VDA surface friction measurements were accomplished using the DRI Mobile Tire Tester. Three runs were done, one at each of three previously determined locations. Each run provided for a minimum of 3 seconds of tire friction at constant normal load, slip angle, and speed in a free rolling condition. The test was accomplished using an ASTM E1136 tire with an inflation pressure of 35 (± 0.5) psi at a test speed of 40 (± 0.5) mph. The net slip angle of the test tire for each test run was 7.5 deg. The test tire was no older than 6 months from the date of manufacture. The surface friction measurement results are shown in Table 5.

Table 5. Surface Friction

Date of surface friction measurements	11/18/2016
Average normalized lateral force	0.903

2. Fishhook Handwheel Angles

The 0.3g handwheel angle obtained from the SIS tests and the handwheel angles used in the Fishhook tests are shown in Table 6.

Table 6. Handwheel Angles

0.3g handwheel angle (from SIS tests at 50 mph)	35.1 °
5.5 scalar handwheel angle for Fishhook Test	193°
6.5 scalar handwheel angle for Fishhook Test	228 °

3. Weather Conditions

The weather conditions, recorded at the end of testing, are shown in Table 7.

Table 7. Weather Conditions

Ambient temperature	60 °F (15.6 °C)
Wind Speed	0 mph (0 m/s)
Wind Direction	S

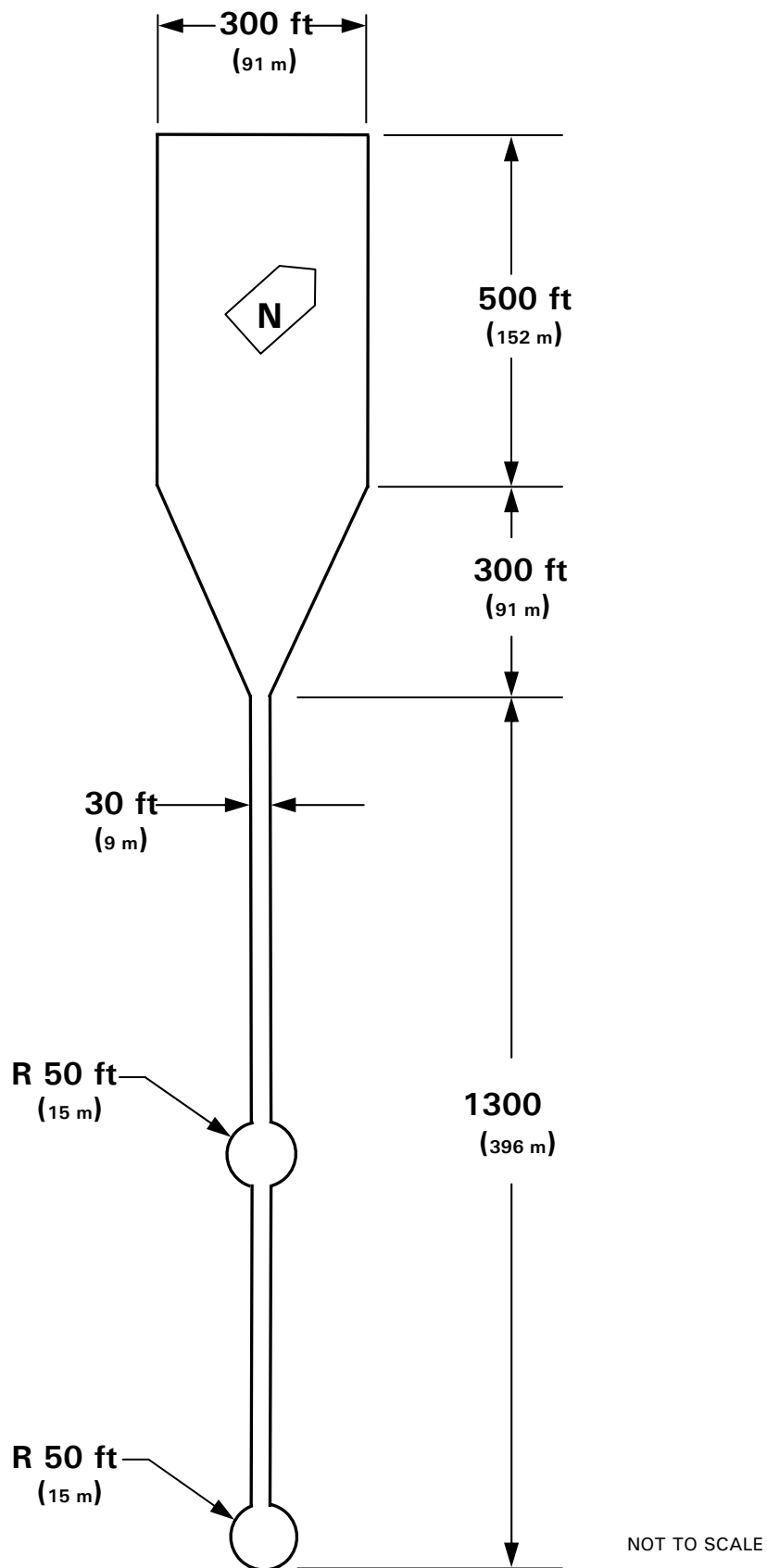

Figure 2. DRI-Minter Vehicle Dynamics Area

Section IV RESULTS

The test run log is given in Appendix B. The Slowly Increasing Steer Test Worksheet is given in Appendix C. Appendix D contains time history plots for the 50 mph runs and any runs which resulted in two-wheel lift. For the 2017 Honda Ridgeline AWD, there was no two-wheel lift at any test condition.

APPENDIX A

Photographs

LIST OF FIGURES

	Page
A1. Window Sticker.....	A-3
A2. Front View, Test Vehicle as Delivered	A-4
A3. Rear View, Test Vehicle as Delivered	A-5
A4. Front View, Test Vehicle in Test Condition.....	A-6
A5. Rear View, Test Vehicle in Test Condition	A-7
A6. Instrumentation in Test Vehicle	A-8
A7. Ballast Condition.....	A-9

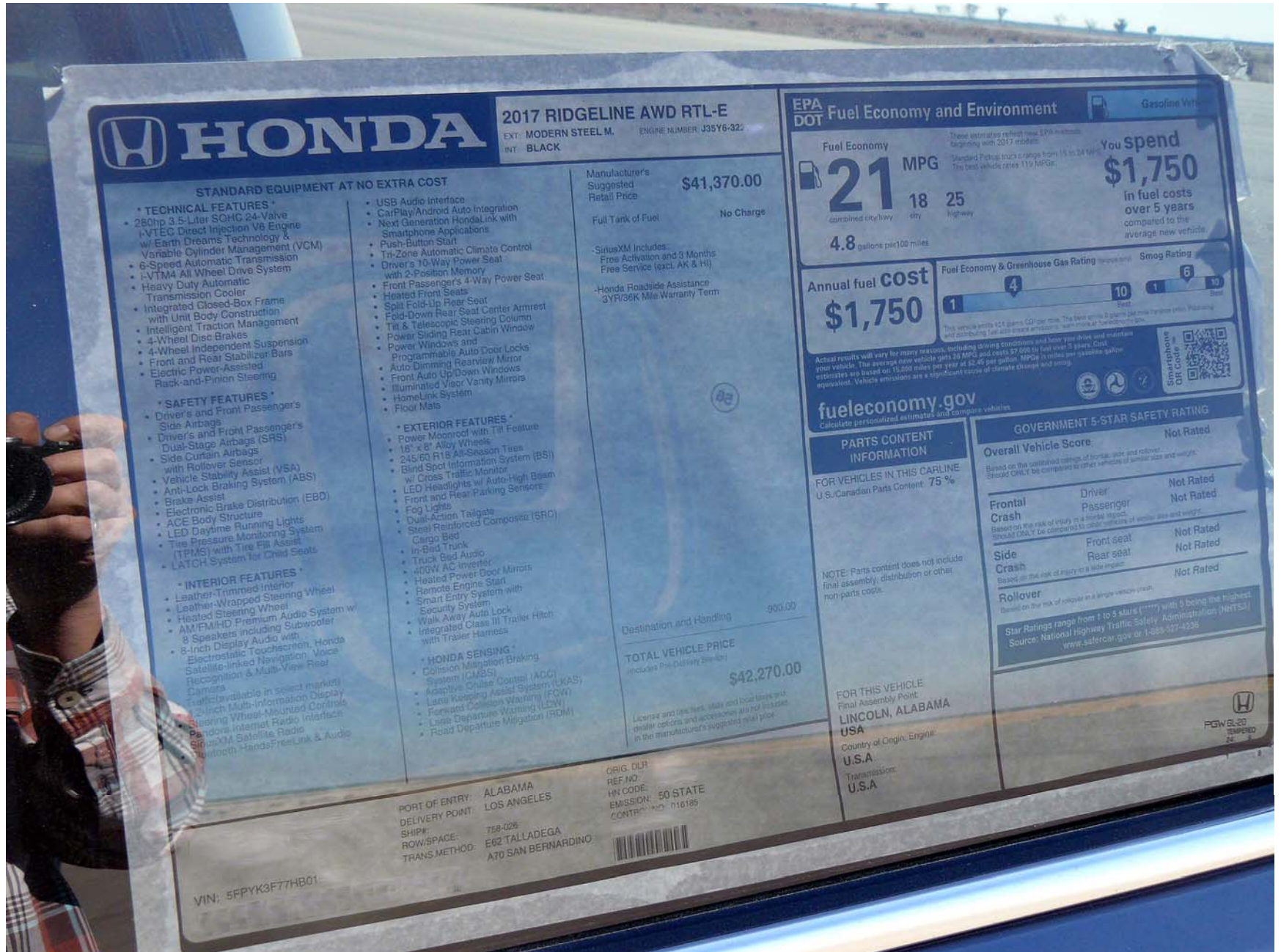

HONDA 2017 RIDGELINE AWD RTL-E
 EXT. MODERN STEEL M. ENGINE NUMBER J35Y6-32Z
 INT. BLACK

- STANDARD EQUIPMENT AT NO EXTRA COST**
- TECHNICAL FEATURES***
 - 280hp 3.5-Liter SOHC 24-Valve i-VTEC Direct Injection V6 Engine w/ Earth Dreams Technology & Variable Cylinder Management (VCM)
 - 6-Speed Automatic Transmission
 - i-VTM4 All Wheel Drive System
 - Heavy Duty Automatic Transmission Cooler
 - Integrated Closed-Box Frame with Unit Body Construction
 - Intelligent Traction Management
 - 4-Wheel Disc Brakes
 - 4-Wheel Independent Suspension
 - Front and Rear Stabilizer Bars
 - Electric Power-Assisted Rack-and-Pinion Steering
 - SAFETY FEATURES***
 - Driver's and Front Passenger's Side Airbags
 - Driver's and Front Passenger's Dual-Stage Airbags (SRS)
 - Side Curtain Airbags with Rollover Sensor
 - Vehicle Stability Assist (VSA)
 - Anti-Lock Braking System (ABS)
 - Brake Assist
 - Electronic Brake Distribution (EBD)
 - ACE Body Structure
 - LED Daytime Running Lights
 - Tire Pressure Monitoring System (TPMS) with Tire Fill Assist
 - LATCH System for Child Seats
 - INTERIOR FEATURES***
 - Leather-Trimmed Interior
 - Leather-Wrapped Steering Wheel
 - Heated Steering Wheel
 - AM/FM/HD Premium Audio System w/ 8 Speakers including Subwoofer
 - 8-Speaker Display Audio with Electrostatic Touchscreen, Honda Satellite-Linked Navigation, Voice Recognition & Multi-View Rear Camera
 - 2.2-Inch Multi-Information Display
 - Steering Wheel-Mounted Controls
 - Pandora Internet Radio Interface
 - Bluetooth Satellite Radio
 - Bluetooth HandsFreeLink & Audio
 - EXTERIOR FEATURES***
 - Power Moonroof with Tilt Feature
 - 18" x 8" Alloy Wheels
 - 245/60 R18 All-Season Tires
 - Blind Spot Information System (BSI) w/ Cross Traffic Monitor
 - LED Headlights w/ Auto-High Beam
 - Front and Rear Parking Sensors
 - Fog Lights
 - Dual-Action Tailgate
 - Steel Reinforced Composite (SRC) Cargo Bed
 - In-Bed Truck
 - Truck Bed Audio
 - 400W AC Inverter
 - Heated Power Door Mirrors
 - Remote Engine Start
 - Smart Entry System with Security System
 - Walk Away Auto Lock
 - Integrated Class III Trailer Hitch with Trailer Harness
 - HONDA SENSING***
 - Collision Mitigation Braking System (CMBS)
 - Adaptive Cruise Control (ACC)
 - Lane Keeping Assist System (LKAS)
 - Lane Departure Warning (LDW)
 - Lane Departure Mitigation (LDM)

Manufacturer's Suggested Retail Price **\$41,370.00**

Full Tank of Fuel **No Charge**

SitrusXM Includes: Free Activation and 3 Months Free Service (excl. AK & HI)

Honda Roadside Assistance 3YR/36K Mile Warranty Term

Destination and Handling **900.00**

TOTAL VEHICLE PRICE (includes Pre-Delivery Fee) **\$42,270.00**

License and title fees, state and local taxes and dealer options and accessories are not included in the manufacturer's suggested retail price.

EPA DOT Fuel Economy and Environment Gasoline Vehicle

Fuel Economy
21 MPG combined city/hwy
 18 city 25 highway
 4.8 gallons per 100 miles

You spend \$1,750 in fuel costs over 5 years compared to the average new vehicle.

Annual fuel cost \$1,750

Fuel Economy & Greenhouse Gas Rating 4 (Best) 10 (Worst)

Smog Rating 6 (Best) 10 (Worst)

Actual results will vary for many reasons, including driving conditions and how you drive and maintain your vehicle. The average new vehicle gets 20 MPG and costs \$7,000 to fuel over 5 years. EPA estimates are based on 15,000 miles per year at \$2.45 per gallon. MPGe is miles per gasoline gallon equivalent. Vehicle emissions are a significant source of climate change and smog.

fuelconomy.gov Calculate personalized estimates and compare vehicles.

PARTS CONTENT INFORMATION

FOR VEHICLES IN THIS COUNTRY
 U.S./Canadian Parts Content: **75%**

NOTE: Parts content does not include final assembly, distribution or other non-parts costs.

GOVERNMENT 5-STAR SAFETY RATING

Overall Vehicle Score: **Not Rated**

Based on the combined ratings of frontal, side and rollover. Should ONLY be compared to other vehicles of similar size and weight.

Frontal Crash	Driver Passenger	Not Rated
Side Crash	Front seat Rear seat	Not Rated
Rollover		Not Rated

Star Ratings range from 1 to 5 stars (*****) with 5 being the highest. Source: National Highway Traffic Safety Administration (NHTSA) www.safercar.gov or 1-888-327-4236

FOR THIS VEHICLE
 Final Assembly Point: **LINCOLN, ALABAMA USA**
 Country of Origin, Engine: **USA**
 Transmission: **USA**

PORT OF ENTRY: ALABAMA
 DELIVERY POINT: LOS ANGELES
 SHIP#: 758-026
 ROW/SPACE: E62 TALLADEGA
 TRANS.METHOD: A70 SAN BERNARDINO

ORIG. DLR REF. NO.
 VIN CODE
 EMISSION: 50 STATE
 CONTR. NO. 116185

VIN: 5FPYK3F77HB01





Figure A2. Front View, Test Vehicle as Delivered



Figure A3. Rear View, Test Vehicle as Delivered



Figure A4. Front View, Test Vehicle in Test Condition



Figure A5. Rear View, Test Vehicle in Test Condition



Figure A6. Instrumentation in Test Vehicle



Figure A7. Ballast Condition

APPENDIX B

Test Run Log

Vehicle: **2017 Honda Ridgeline AWD**Driver: **Peter Broen**Date: **11/18/2016**

Run Number	Test Type	Speed (mph)	Handwheel Angle (deg)	Dir. of First Steer	2 Wheel Lift	Notes
1	Tire Warm-Up	35	80		NA	
2	Tire Warm-Up	35	80		NA	
3	Tire Warm-Up	35	80		NA	
4						2x SWA last cycle
5	Static	0	0		NA	
6	Steady State	50	0		NA	
7	SIS	50	50	Left	NA	Resulted in $a_y = 0.60g$
8	SIS	50	50	Left	NA	
9	SIS	50	50	Left	NA	ng
10	SIS	50	50	Right	NA	
11	SIS	50	50	Right	NA	
12	SIS	50	50	Right	NA	
13	Fishhook	35	228	Left	No	6.5x scalar
14	Fishhook	40	228	Left	No	
15	Fishhook	45	228	Left	No	
16	Fishhook	47.5	228	Left	No	
17	Fishhook	50	228	Left	No	
18	Fishhook	35	228	Right	No	
19	Fishhook	40	228	Right	No	
20	Fishhook	45	228	Right	No	
21	Fishhook	47.5	228	Right	No	
22	Fishhook	50	228	Right	No	
23	Fishhook	45	193	Right	No	5.5x scalar
24	Fishhook	47.5	193	Right	No	

Vehicle: **2017 Honda Ridgeline AWD**Driver: **Peter Broen**Date: **11/18/2016**

Run Number	Test Type	Speed (mph)	Handwheel Angle (deg)	Dir. of First Steer	2 Wheel Lift	Notes
25	Fishhook	50	193	Right	No	
26	Fishhook	45	193	Left	No	
27	Fishhook	47.5	193	Left	No	
28	Fishhook	50	193	Left	No	

APPENDIX C

Slowly Increasing Steer Test Worksheet

NCAP, 2017 Honda Ridgeline AWD , Multi-Passenger Load, Test Date: 11/18/2016

SIS_out_v2

Run	Dir of Steer	Start Speed (mph)	End Speed (mph)	Speed Red. (%)	Index of ay @ 0.3g	HW Angle (deg) at 0.3g	ay (g) @ 0.3g index	6.5x HW Angle (deg)	Ramp Time (sec) at 6.5x	5.5x HW Angle (deg)	Ramp Time (sec) at 5.5x	R2	Zero Begin Index	Zero End Index
7	1	49.3	7.1	85.5	1017	-34.8	-0.297	-226.2	-0.3141	-191.4	-0.2658	0.9945	301	500
8	1	49.8	2.6	94.8	1020	-35	-0.296	-227.5	-0.3160	-192.5	-0.2674	0.9952	301	500
9	1	49.2	7.1	85.6	1022	-35.1	-0.306	-228.2	-0.3170	-193.1	-0.2682	0.9873	301	500
10	0	49.5	6.1	87.7	1023	35.1	0.306	228.4	0.3172	193.3	0.2684	0.9904	300	500
11	0	49.5	9.8	80.3	1025	35.3	0.302	229.4	0.3187	194.1	0.2696	0.9912	300	500
12	0	49.5	5.1	89.7	1025	35.3	0.297	229.4	0.3186	194.1	0.2696	0.9931	300	500

Mean: 35.1 0.301 228 0.317 193 0.268

Steering Controller Input Values

Scalar 6.5 values:

Initial HW angle: 228 deg
Initial time: 0.317 s
Reversal HW angle: -228 deg
Reversal time: 0.634 s

Scalar 5.5 values:

Initial HW angle: 193 deg
Initial time: 0.268 s
Reversal HW angle: -193 deg
Reversal time: 0.536 s

APPENDIX D

Time History Plots

LIST OF FIGURES

	Page
D1. Vehicle Speed, Handwheel Angle, and Roll Angle Time History Plots for Default Test Series, L-R, 50 mph	D-3
D2. Steering Machine Operation Time History Plots for Default Test Series, L-R, 50 mph.....	D-4
D3. Yaw Rate, Roll Rate, and Lateral Acceleration Time History Plots for Default Test Series, L-R, 50 mph	D-5
D4. Pitch Rate and Longitudinal Acceleration Time History Plots for Default Test Series, L-R, 50 mph	D-6
D5. Vehicle Speed, Handwheel Angle, and Roll Angle Time History Plots for Default Test Series, R-L, 50 mph	D-7
D6. Steering Machine Operation Time History Plots for Default Test Series, R-L, 50 mph	D-8
D7. Yaw Rate, Roll Rate, and Lateral Acceleration Time History Plots for Default Test Series, R-L, 50 mph	D-9
D8. Pitch Rate and Longitudinal Acceleration Time History Plots for Default Test Series, R-L, 50 mph	D-10
D9. Vehicle Speed, Handwheel Angle, and Roll Angle Time History Plots for Supplemental 2 Test Series, L-R, 50 mph.....	D-11
D10. Steering Machine Operation Time History Plots for Supplemental 2 Test Series, L-R, 50 mph.....	D-12
D11. Yaw Rate, Roll Rate, and Lateral Acceleration Time History Plots for Supplemental 2 Test Series, L-R, 50 mph.....	D-13
D12. Pitch Rate and Longitudinal Acceleration Time History Plots for Supplemental 2 Test Series, L-R, 50 mph.....	D-14
D13. Vehicle Speed, Handwheel Angle, and Roll Angle Time History Plots for Supplemental 2 Test Series, R-L, 50 mph.....	D-15
D14. Steering Machine Operation Time History Plots for Supplemental 2 Test Series, R-L, 50 mph.....	D-16
D15. Yaw Rate, Roll Rate, and Lateral Acceleration Time History Plots for Supplemental 2 Test Series, R-L, 50 mph.....	D-17
D16. Pitch Rate and Longitudinal Acceleration Time History Plots for Supplemental 2 Test Series, R-L, 50 mph.....	D-18

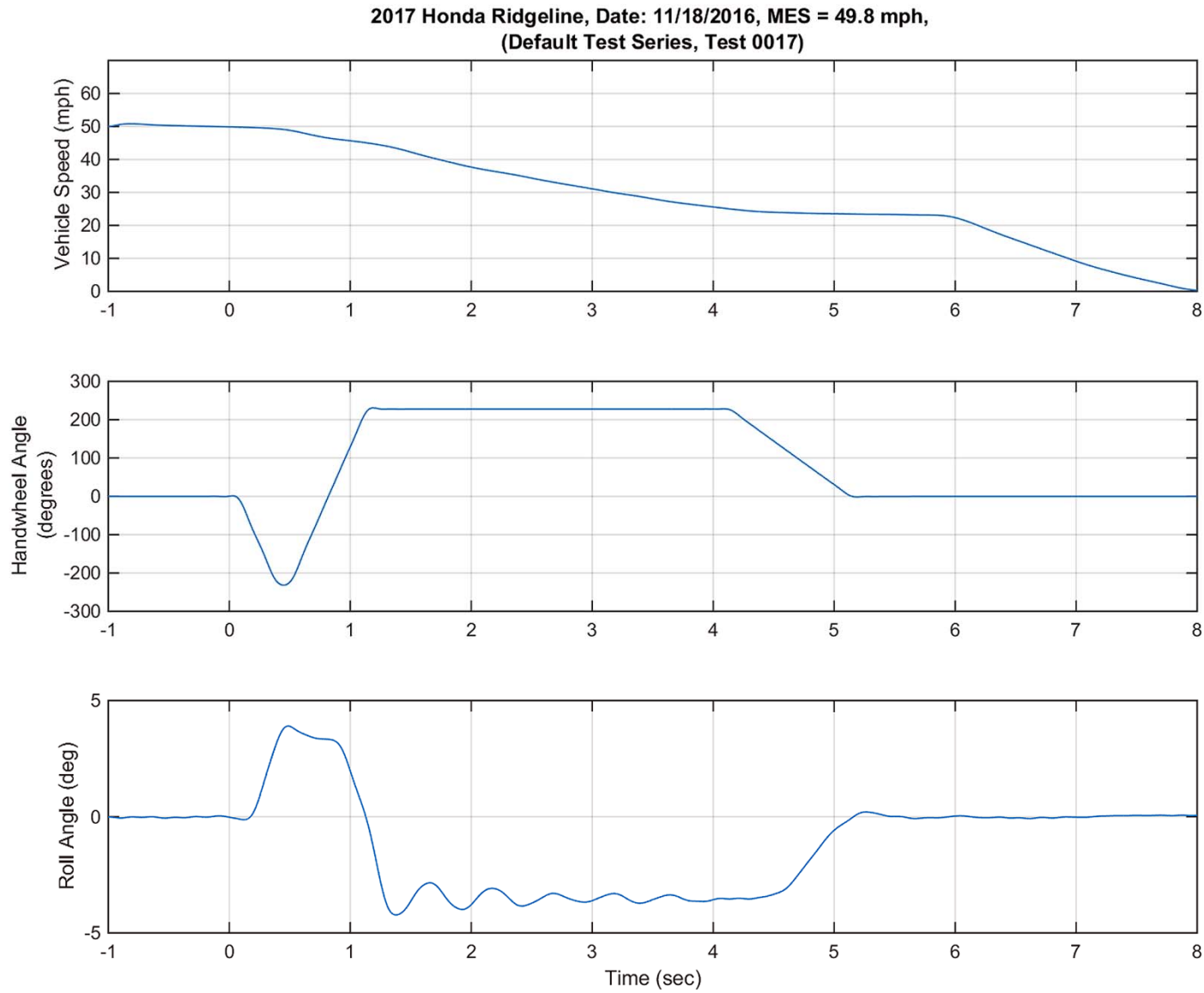

Figure D1. Vehicle Speed, Handwheel Angle, and Roll Angle Time History Plots for Default Test Series, L-R, 50 mph

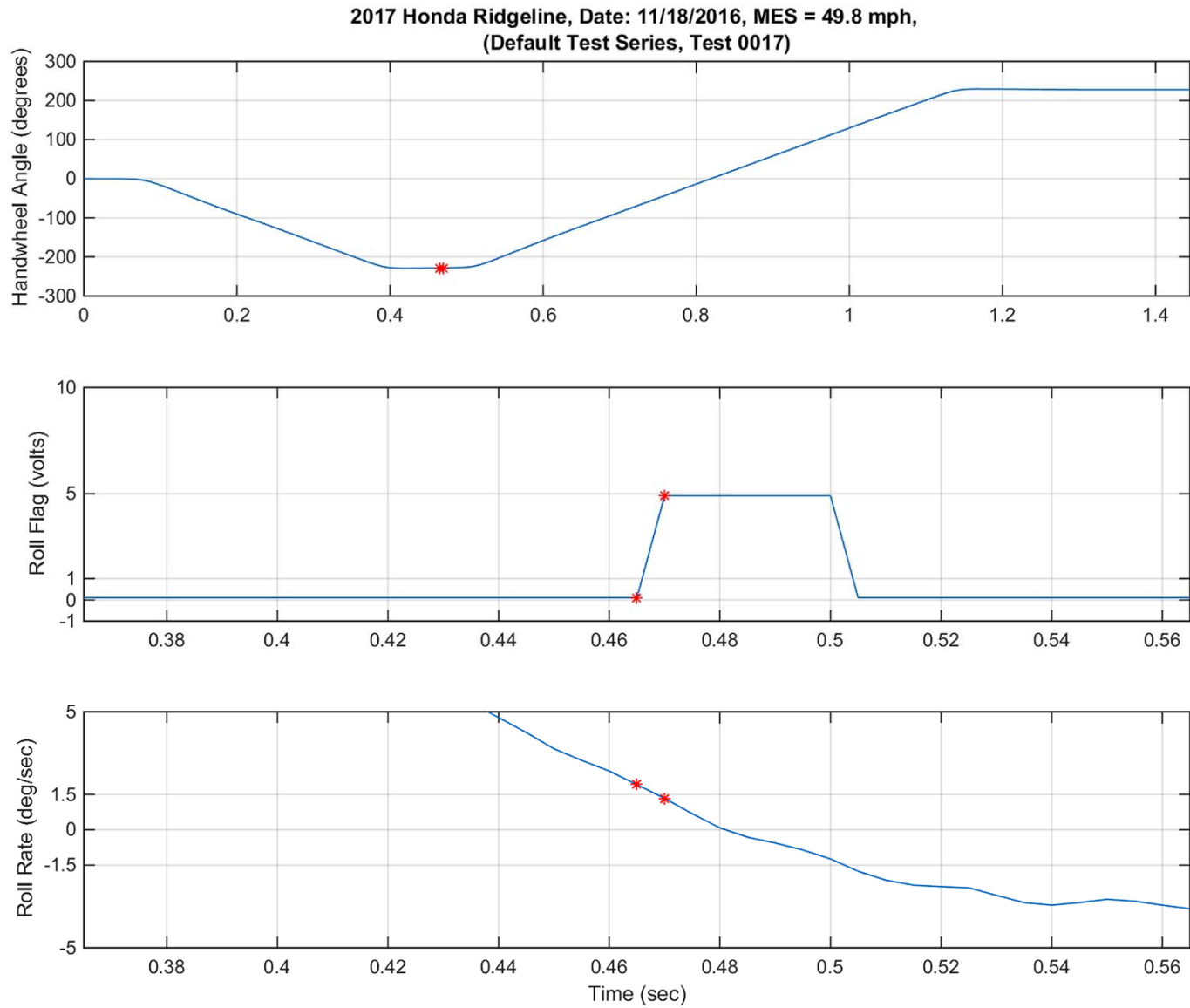

Figure D2. Steering Machine Operation Time History Plots for Default Test Series, L-R, 50 mph

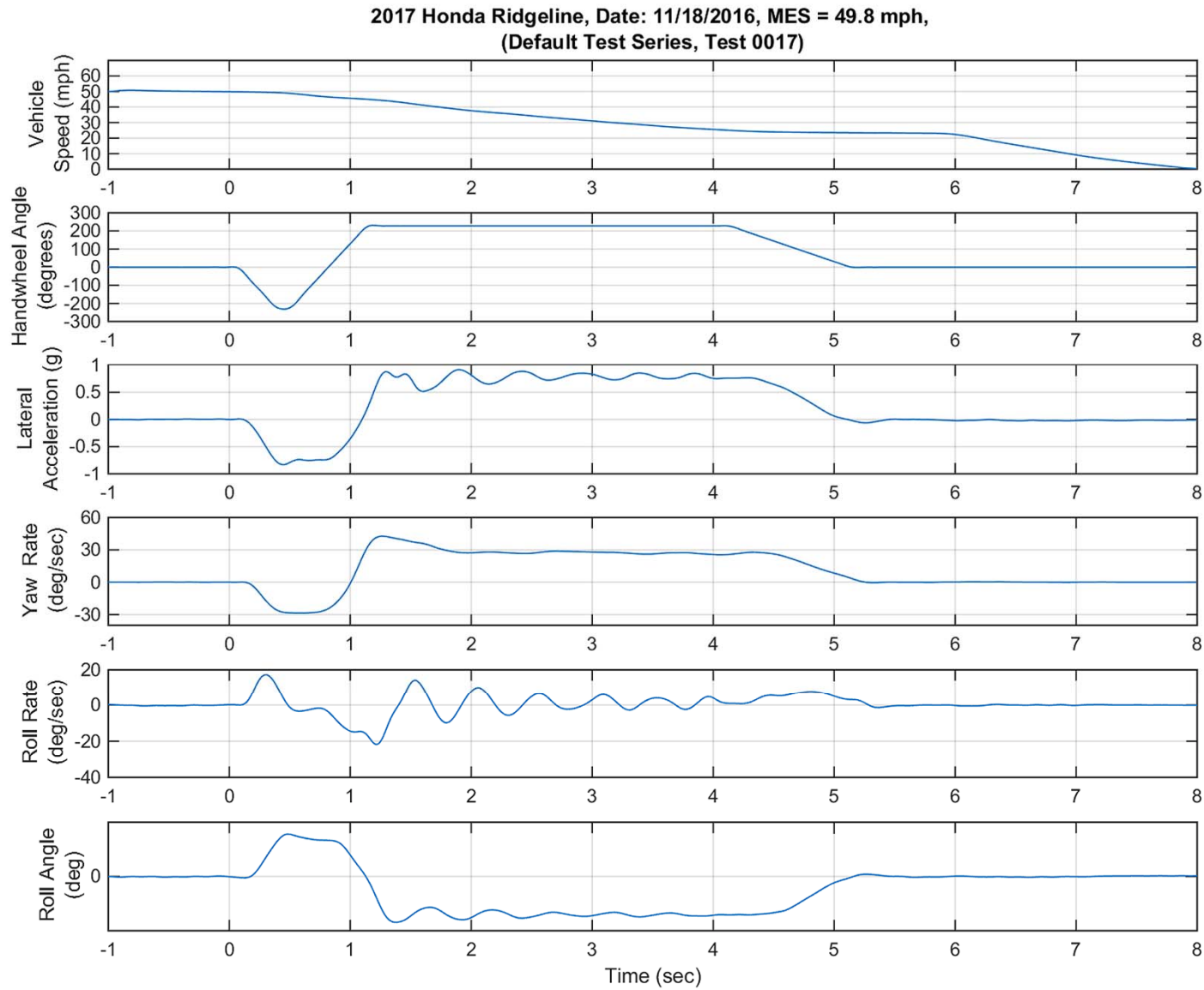

Figure D3. Yaw Rate, Roll Rate, and Lateral Acceleration Time History Plots For Default Test Series, L-R, 50 mph

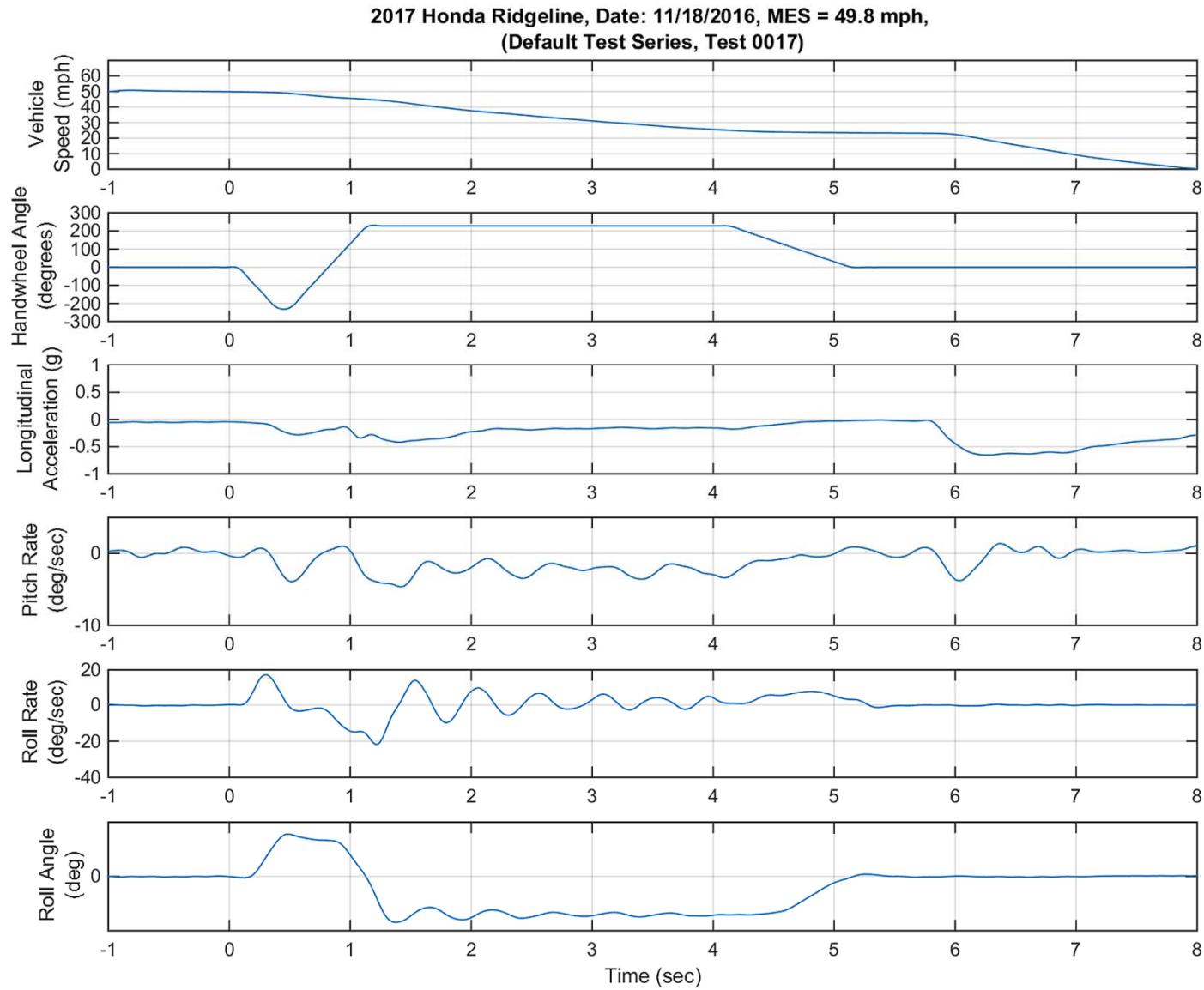

Figure D4. Pitch Rate and Longitudinal Acceleration Time History Plots for Default Test Series, L-R, 50 mph

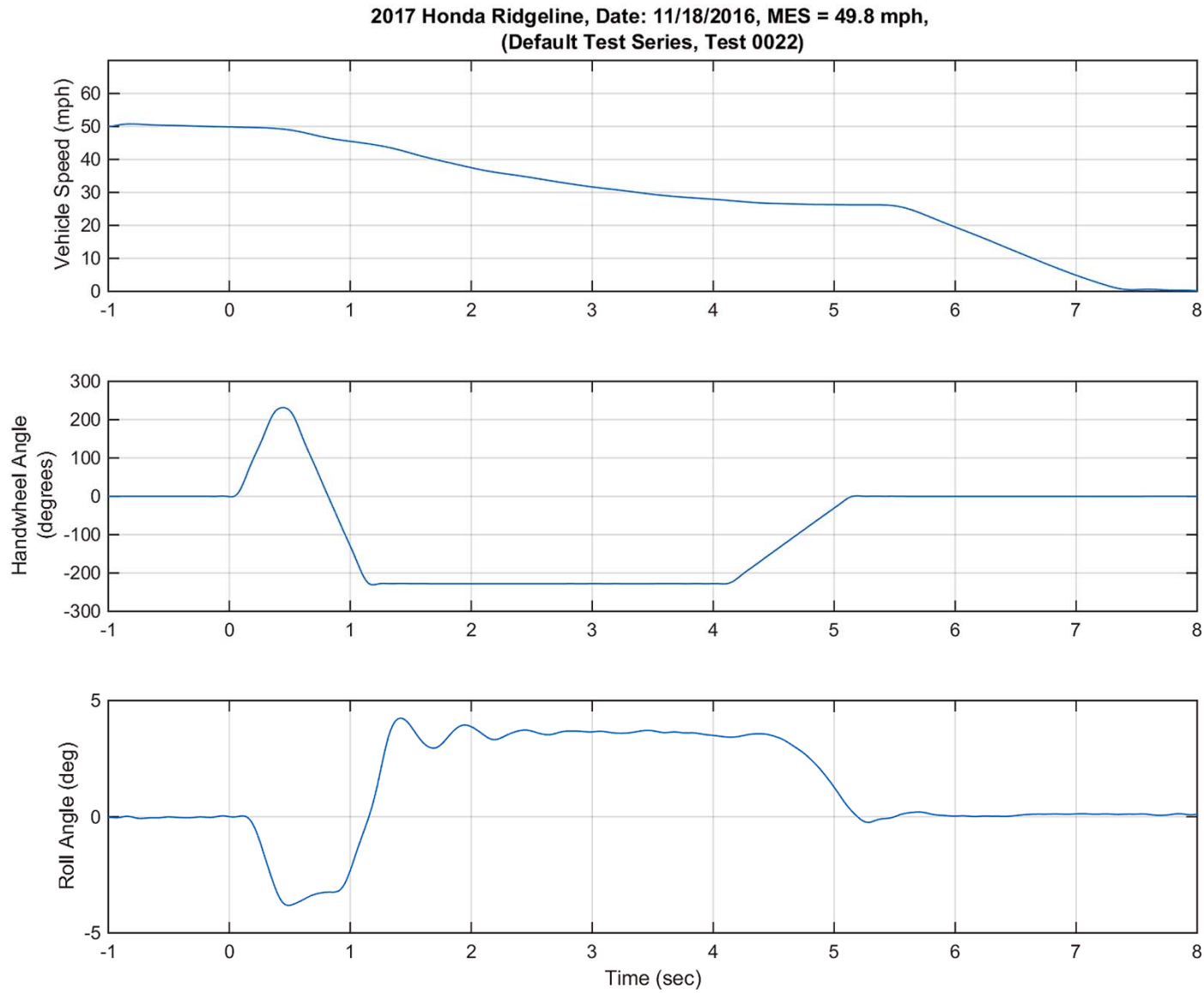

Figure D5. Vehicle Speed, Handwheel Angle, and Roll Angle Time History Plots for Default Test Series, R-L, 50 mph

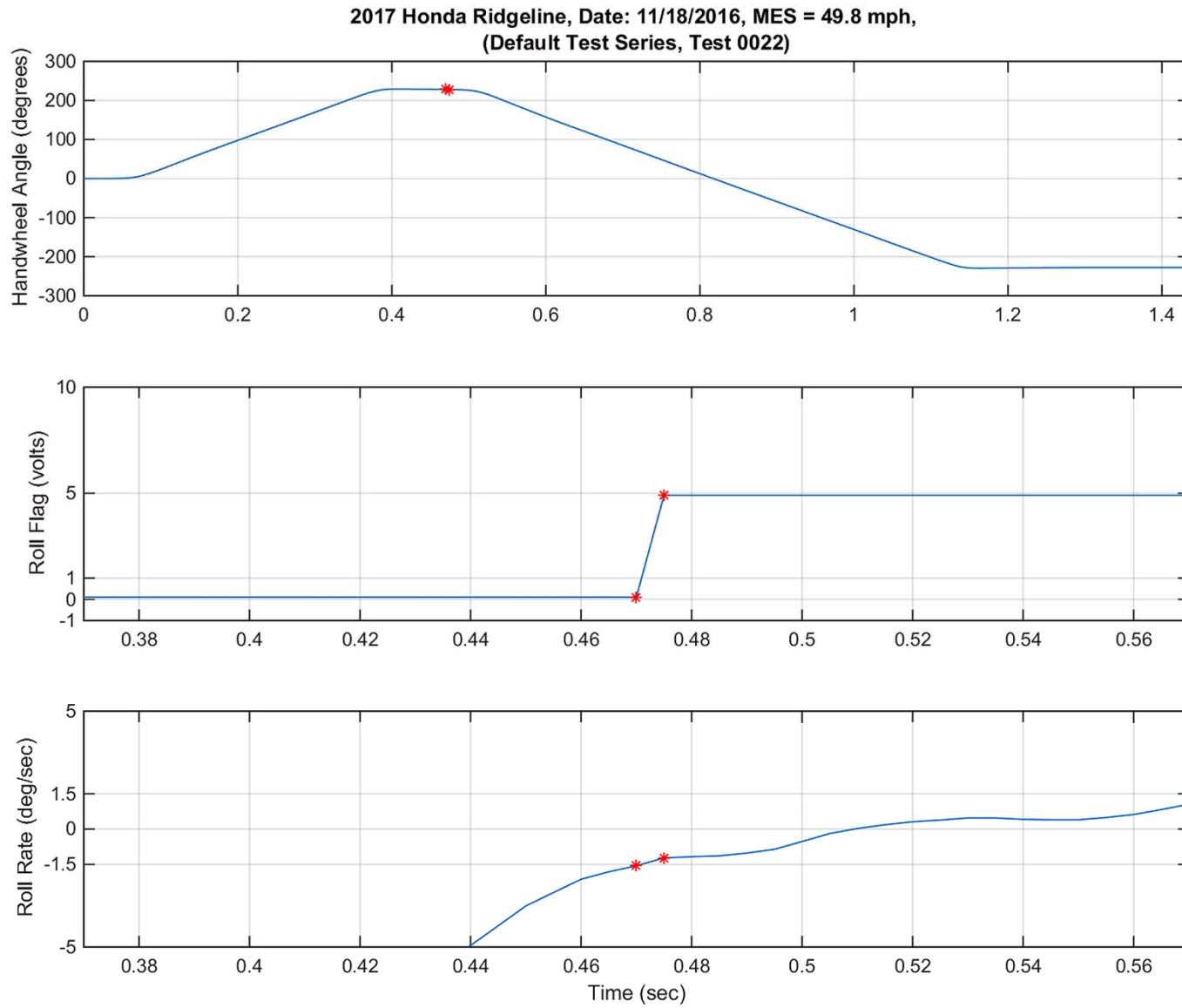

Figure D6. Steering Machine Operation Time History Plots for Default Test Series, R-L, 50 mph

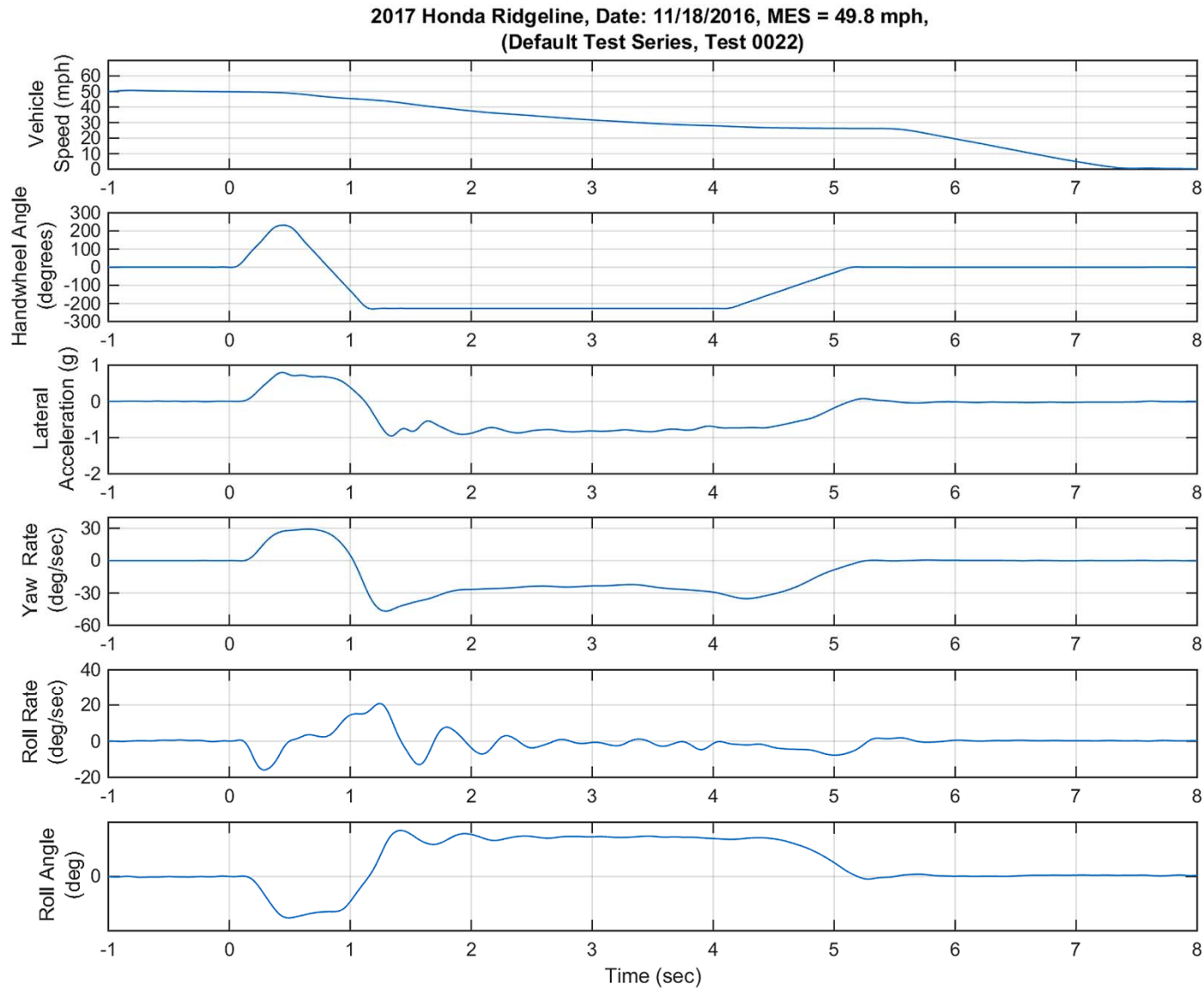

Figure D7. Yaw Rate, Roll Rate, and Lateral Acceleration Time History Plots for Default Test Series, R-L, 50 mph

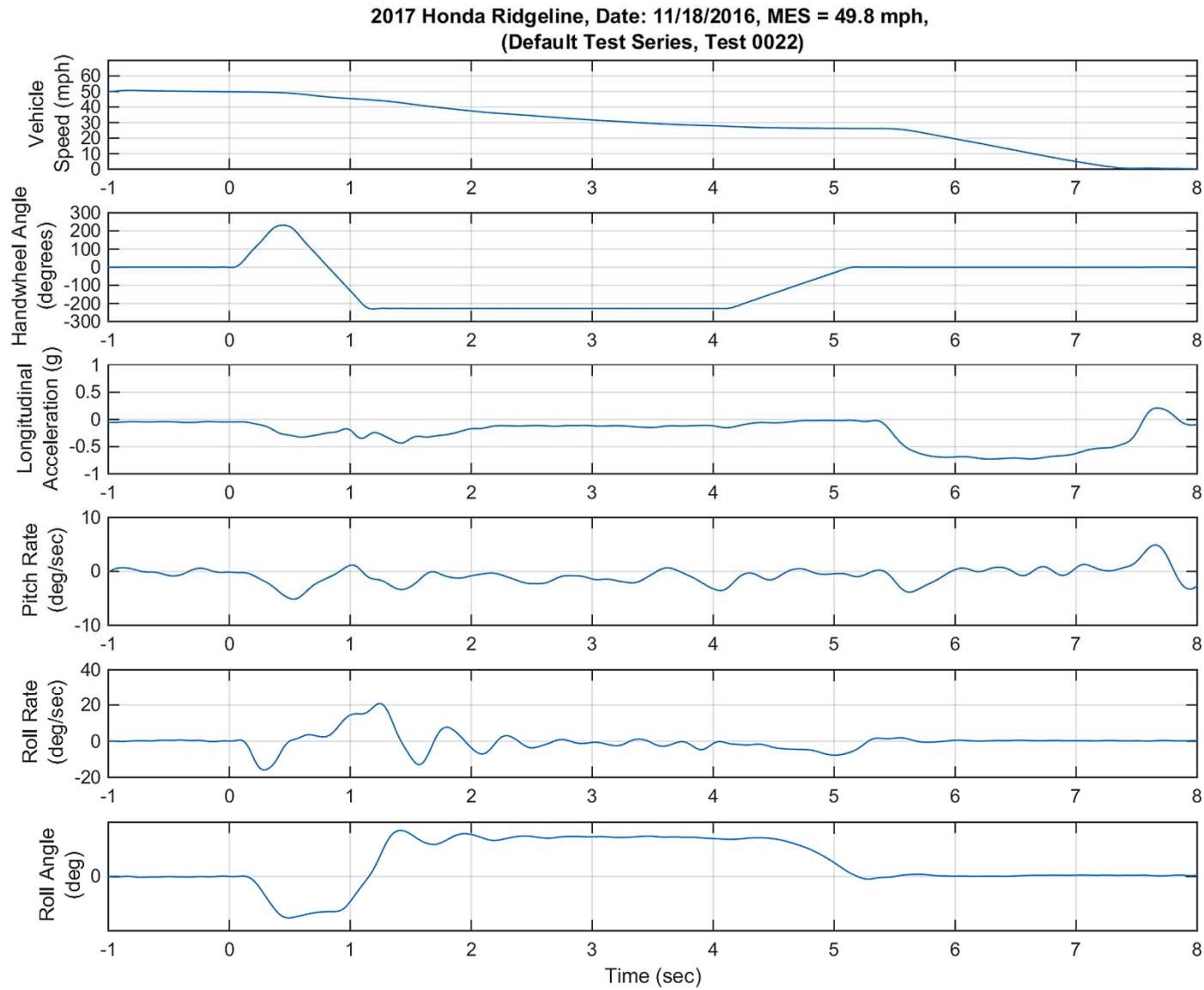

Figure D8. Pitch Rate and Longitudinal Acceleration Time History Plots or Default Test Series, R-L, 50 mph

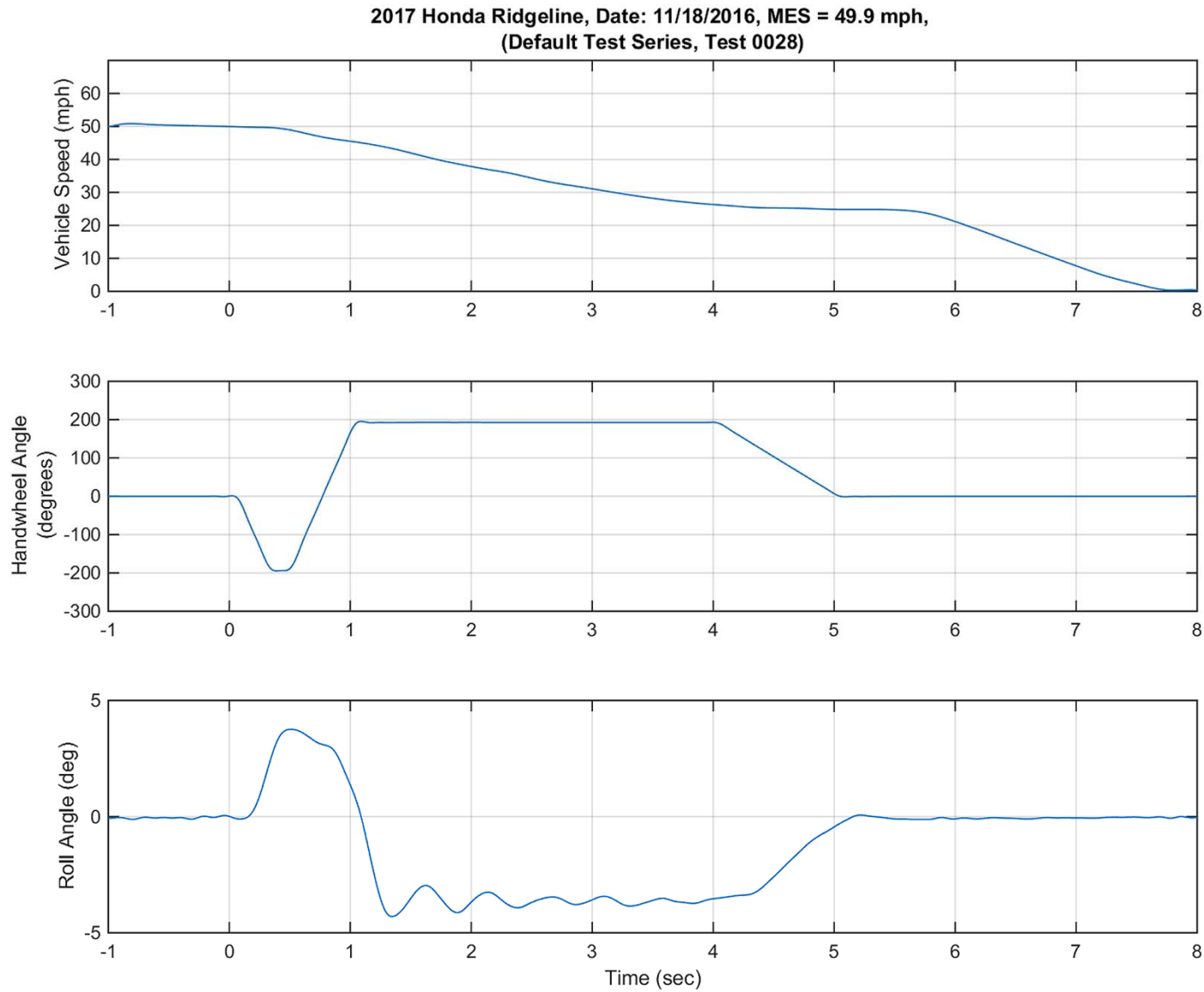

Figure D9. Vehicle Speed, Handwheel Angle, and Roll Angle Time History Plots for Supplemental 2 Test Series, L-R, 50 mph

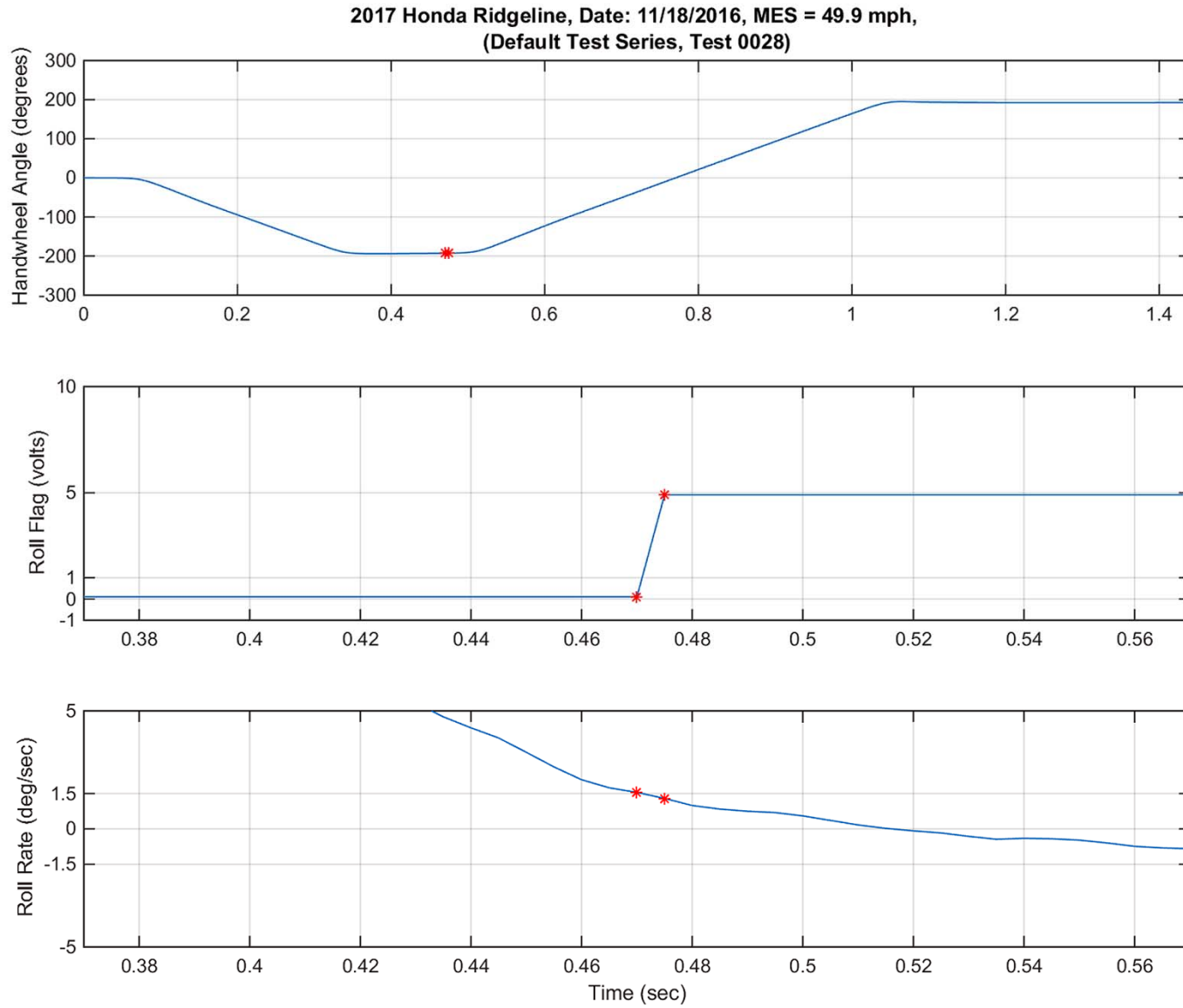

Figure D10. Steering Machine Operation Time History Plots for Supplemental 2 Test Series, L-R, 50 mph

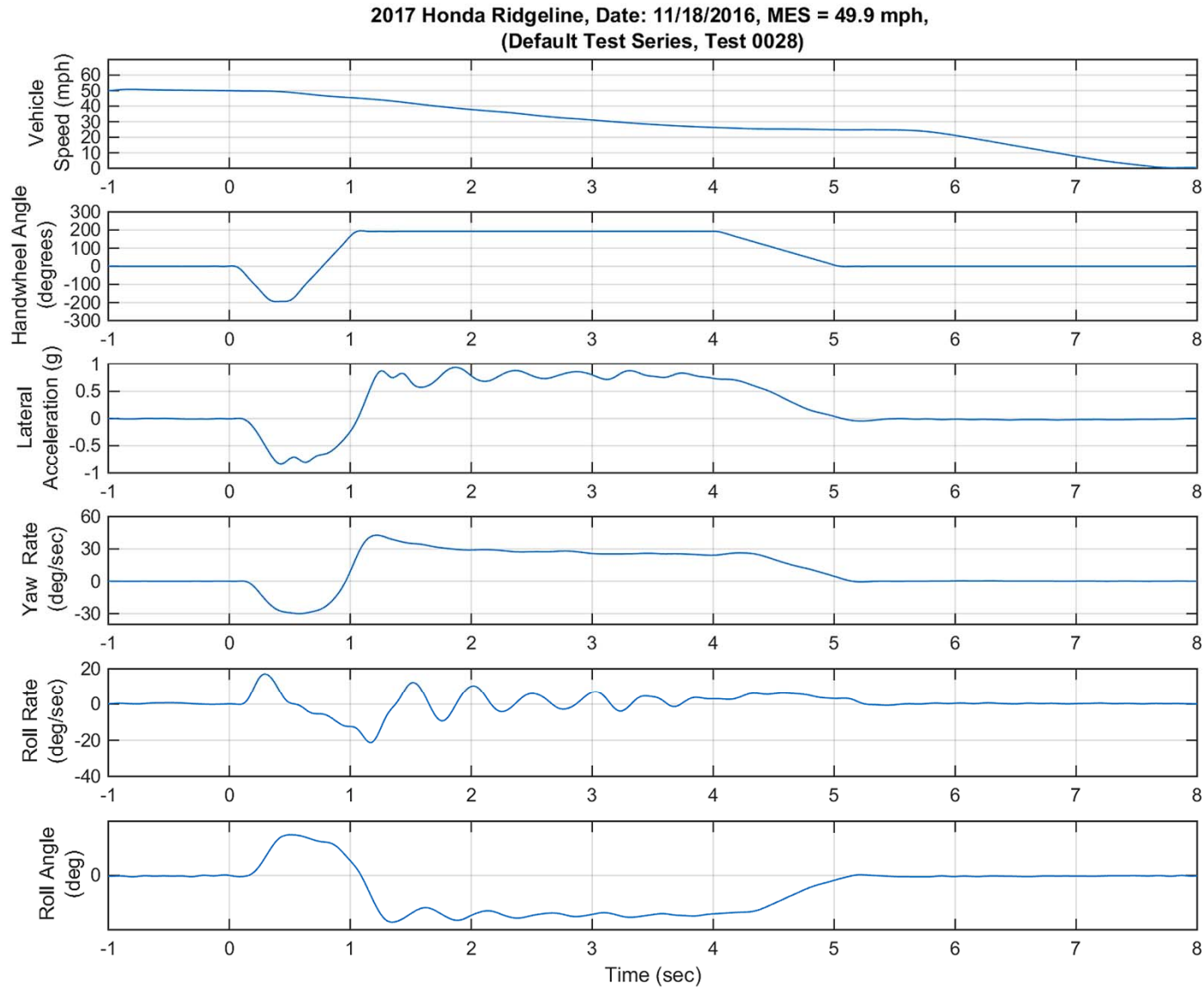

Figure D11. Yaw Rate, Roll Rate, and Lateral Acceleration Time History Plots for Supplemental 2 Test Series, L-R, 50 mph

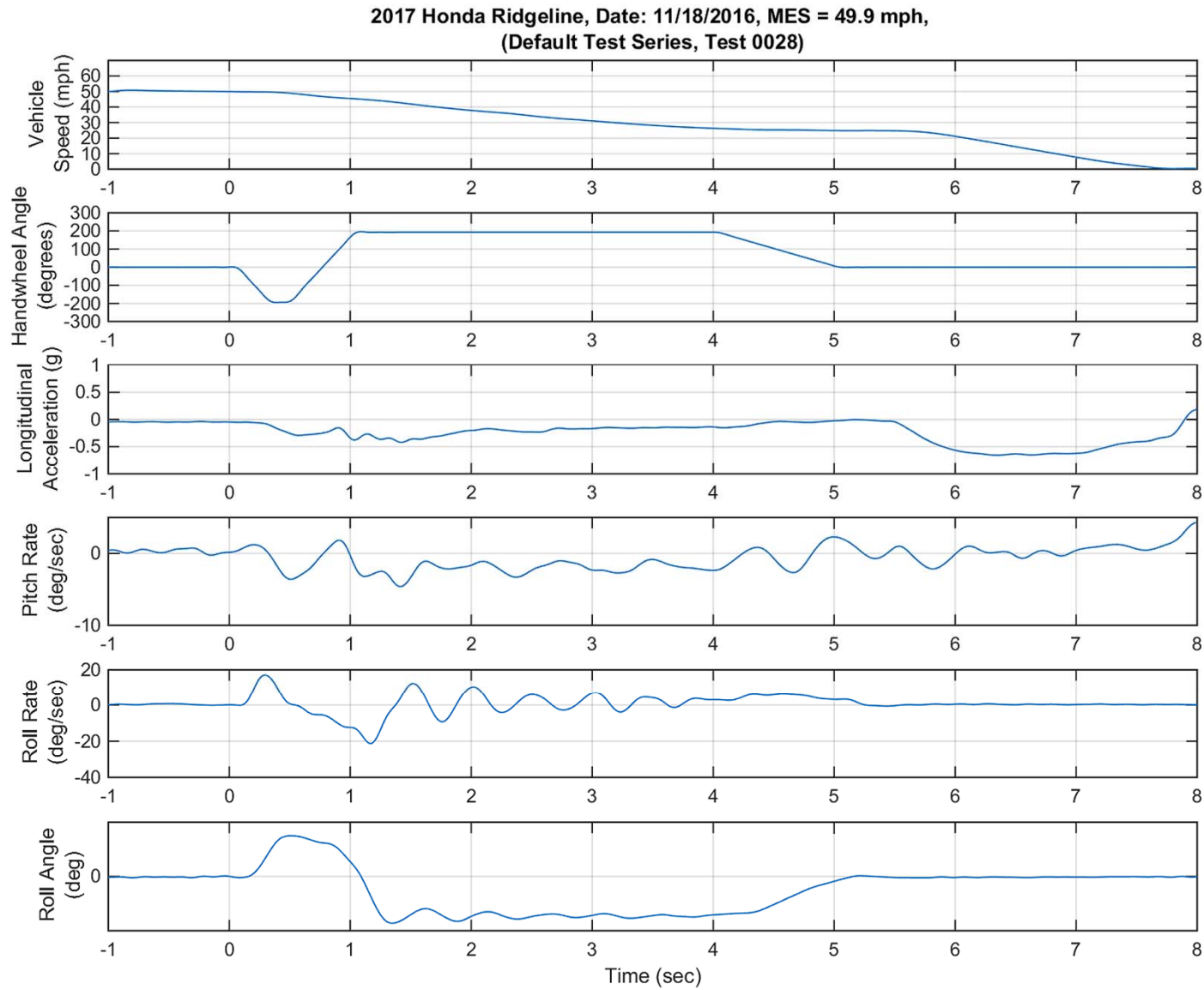

Figure D12. Pitch Rate and Longitudinal Acceleration Time History Plots for Supplemental 2 Test Series, L-R, 50 mph

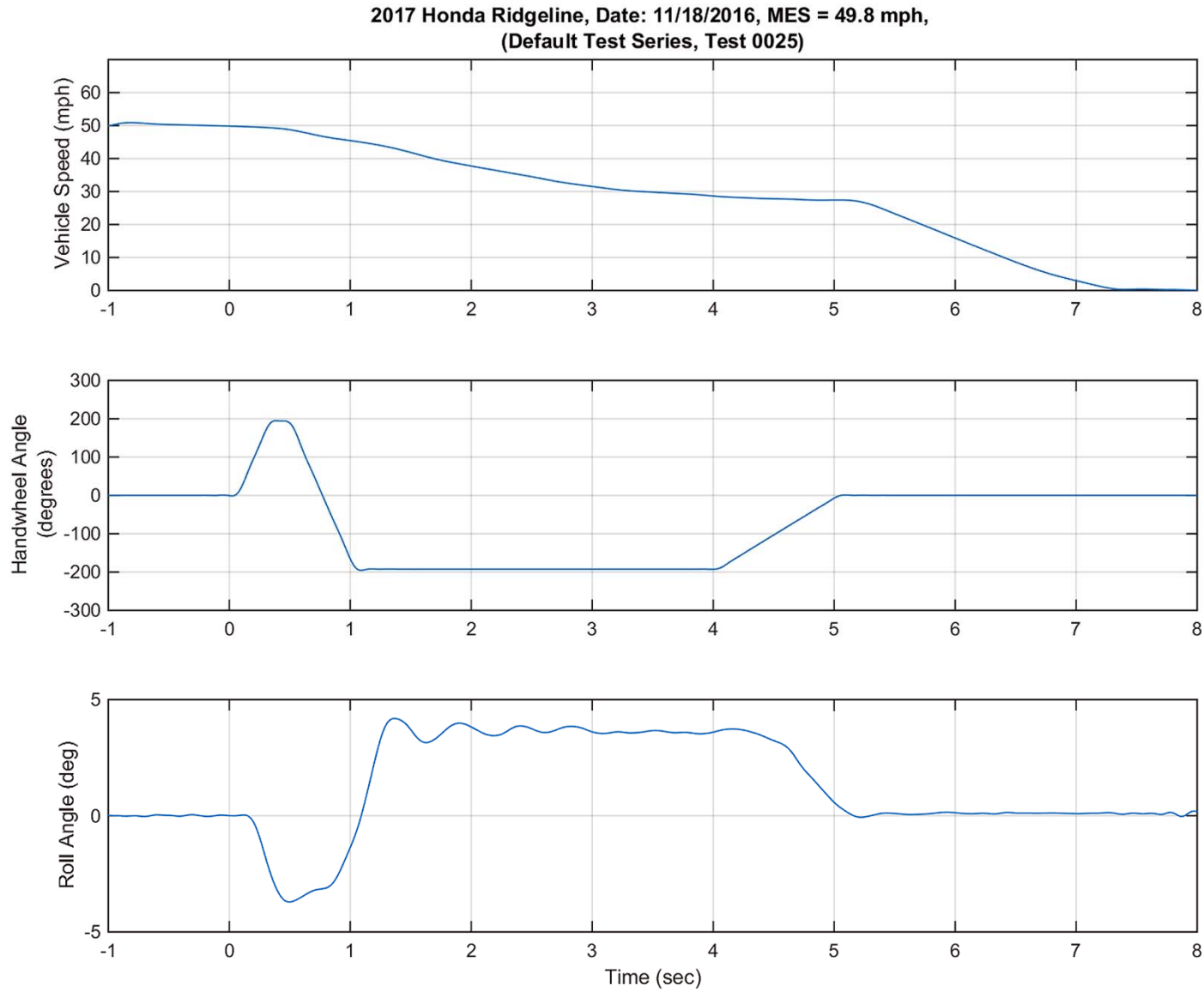

Figure D13. Vehicle Speed, Handwheel Angle, and Roll Angle Time History Plots for Supplemental 2 Test Series, R-L, 50 mph

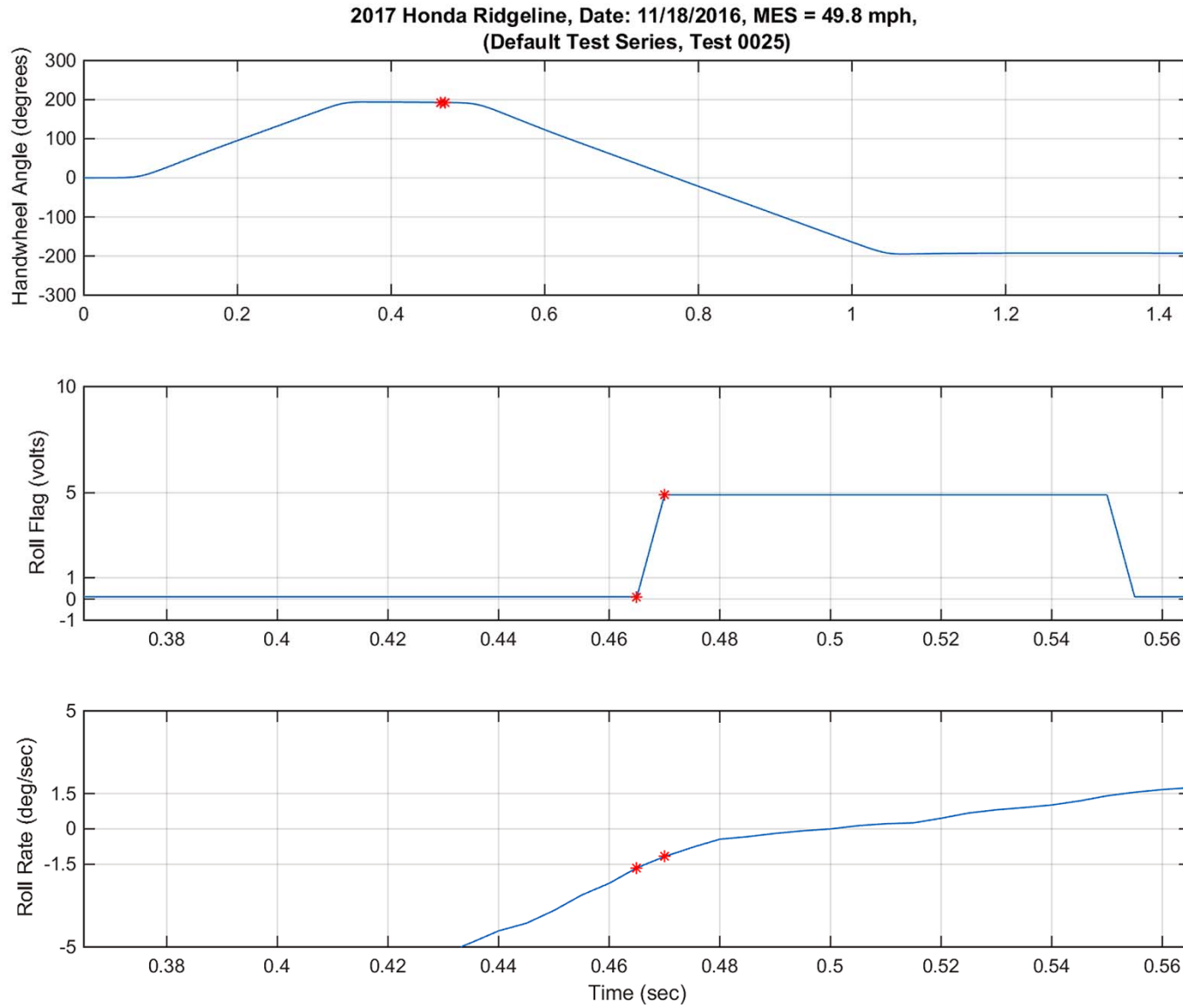

Figure D14. Steering Machine Operation Time History Plots for Supplemental 2 Test Series, R-L, 50 mph

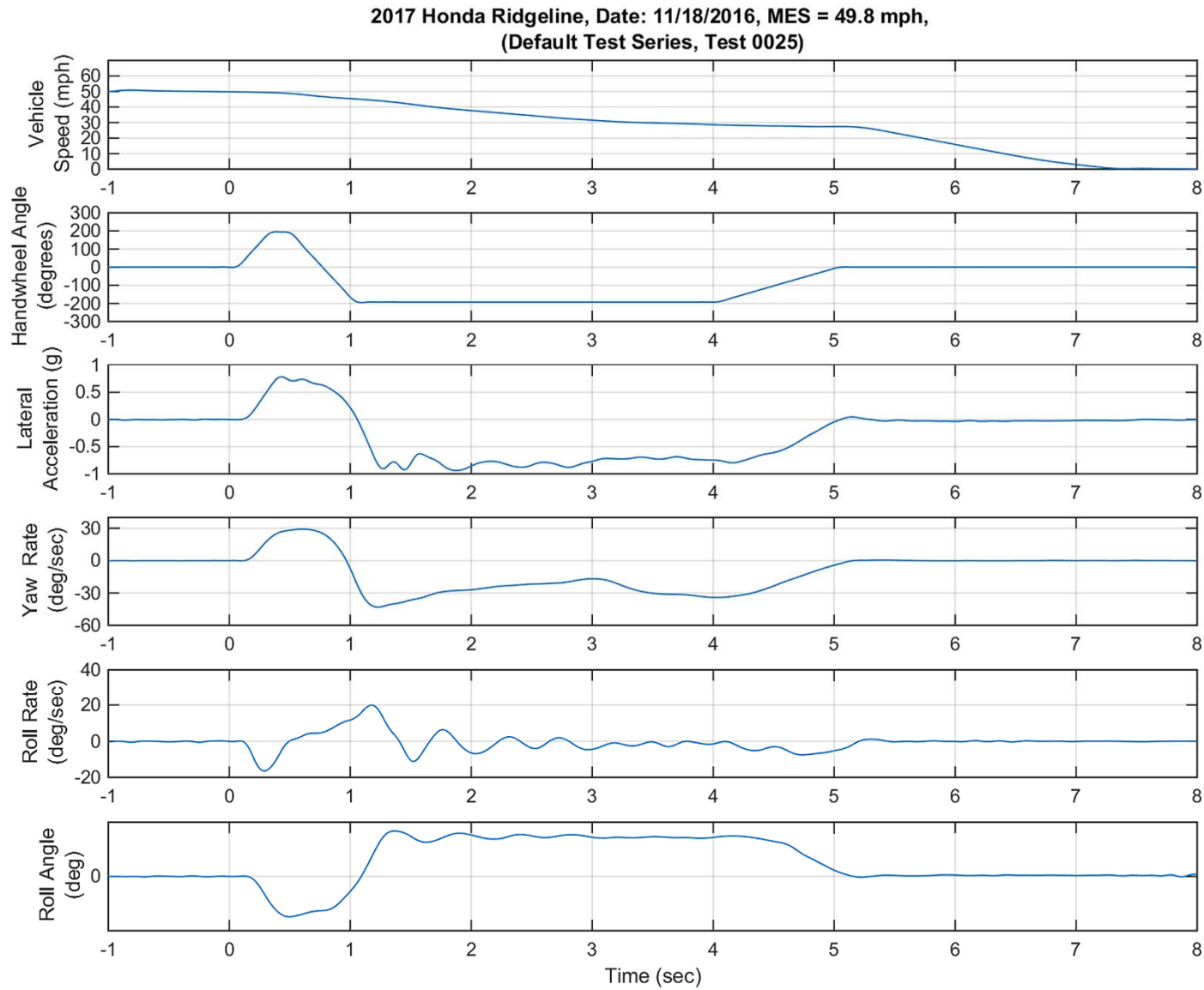

Figure D15. Yaw Rate, Roll Rate, and Lateral Acceleration Time History Plots for Supplemental 2 Test Series, R-L, 50 mph

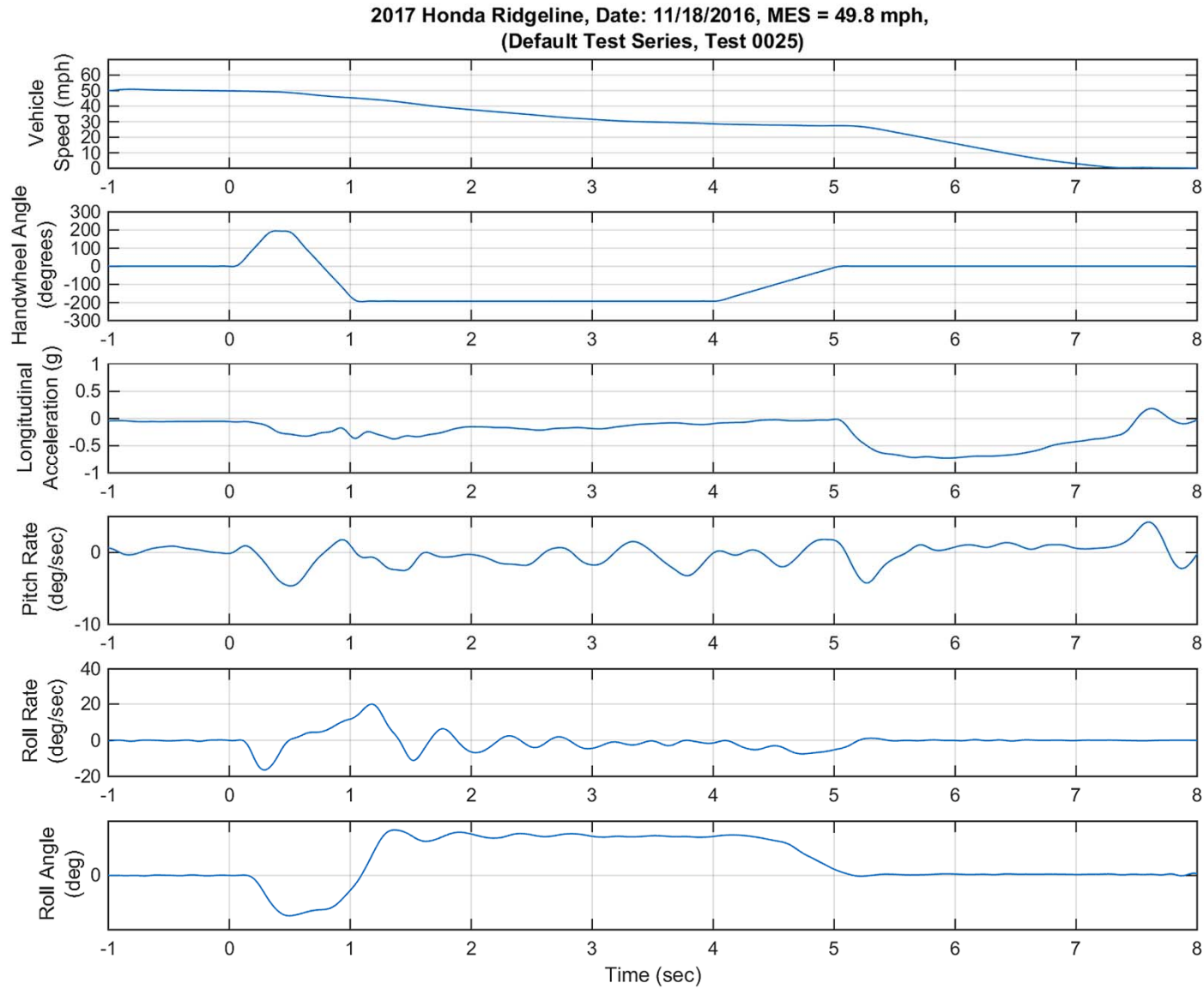

Figure D16. Pitch Rate and Longitudinal Acceleration Time History Plots for Supplemental 2 Test Series, R-L, 50 mph