

**NEW CAR ASSESSMENT PROGRAM (NCAP)
DYNAMIC ROLLOVER RESISTANCE TEST**

FCA US LLC

2018 Jeep Compass FWD

TEST NUMBER: 18-16

Final Report
21 November 2017



Prepared by:

Dynamic Research, Inc
355 Van Ness Ave. #200
Torrance, CA 90501

Prepared for:

National Highway Traffic Safety Administration
Office of Crash Avoidance Standards
1200 New Jersey Avenue S.E.
Washington, DC 20590

The United States Government assumes no liability for the contents of this report or use thereof. If trade or manufacturers' names or products are mentioned, it is only because they are considered essential to the object of the publication and should not be construed as an endorsement. The United States Government does not endorse products or manufacturers.

Dynamic Research, Inc. does not endorse or certify products of manufacturers. The manufacturer's name appears solely to identify the test article. Dynamic Research, Inc. assumes no liability for the report or use thereof. It is responsible for the facts and the accuracy of the data presented herein. This report does not constitute a standard, specification, or regulation.

Report Prepared by:

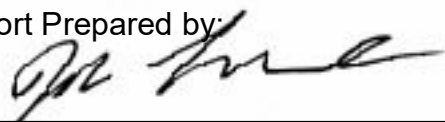

John Lenkeit, Program Manager

Date: 21 November 2017

Report Approved by:



Peter Broen, Principal Engineer

Date: 21 November 2017

1. Report No. 18-16	2. Government Accession No.	3. Recipient's Catalog No.	
4. Title and Subtitle NCAP Dynamic Rollover Resistance Maneuver (Fishhook) Test of a 2018 Jeep Compass FWD SUV		5. Report Date 21 November 2017	
		6. Performing Organization Code DRI	
7. Author(s) John Lenkeit, Program Manager Peter Broen, Project Engineer		8. Performing Organization Report No. DRI- TM-17-196	
9. Performing Organization Name and Address Dynamic Research, Inc. 355 Van Ness Ave. #200 Torrance, CA 90501		10. Work Unit No. (TRAIS)	
		11. Contract or Grant No. DTNH22-14-D-00332	
12. Sponsoring Agency Name and Address National Highway Traffic Safety Administration Office of Crash Avoidance Standards 1200 New Jersey Avenue S.E. Washington, DC 20590		13. Type of Report and Period Covered Final Report October to November 2017	
		14. Sponsoring Agency Code	
15. Supplemental Notes			
16. Abstract An NCAP Dynamic Rollover Maneuver (Fishhook) Test was conducted on a 2018 Jeep Compass FWD at Dynamic Research, Inc. on November 2, 2017. The vehicle did not experience two-wheel lift. The vehicle's steering angle at 0.3 g lateral acceleration at 50 mph was 28.1 degrees.			
17. Key Words NCAP Rollover Resistance Ratings Fishhook Test		18. Distribution Statement Copies of this report are available from: National Highway Traffic Safety Admin. Office of Crash Avoidance Standards 1200 New Jersey Ave., S.E. Washington, DC 20590	
19. Security Classif. (of this report) Unclassified	20. Security Classif. (of this page) Unclassified	21. Number of Pages 53	22. Price

TABLE OF CONTENTS

	Page
I. INTRODUCTION.....	1
II. VEHICLE PREPARATION	2
A. Test Vehicle	2
B. Tires	2
C. Vehicle Loading.....	2
D. Steering Controller	5
E. Instrumentation and Data Collection	5
F. Other Vehicle Preparation	5
III. TEST PROCEDURES.....	9
A. Test Procedure Overview.....	9
B. Test Conditions	10
IV. RESULTS.....	13
APPENDIX A Photographs	A-1
APPENDIX B Test Run Log.....	B-1
APPENDIX C Slowly Increasing Steer Test Worksheet.....	C-1
APPENDIX D Time History Plots	D-1

LIST OF FIGURES

	Page
1. Nominal Position of Video Cameras for Fishhook Tests	8
2. DRI-Minter Vehicle Dynamics Area	12

LIST OF TABLES

	Page
1. Test Vehicle Data	3
2. Tire Information	4
3. Vehicle Loading	4
4. Sensors	7
5. Surface Friction	10
6. Handwheel Angles	10
7. Weather Conditions	11

Section I
INTRODUCTION

Beginning with the 2006 fiscal year, the National Highway Traffic Safety Administration (NHTSA) has engaged Dynamic Research, Inc. (DRI) of Torrance, CA to conduct dynamic rollover testing and gather data from that testing as part of NHTSA's New Car Assessment Program (NCAP).

The purpose of the testing reported herein was to determine if a typical 2018 Jeep Compass FWD would experience tip-up, defined as simultaneous two-wheel lift of two inches or more at an entry speed of 50 mph or less in the Fishhook Procedure developed by NHTSA. This procedure may be found at www.regulations.gov, docket item NHTSA-2006-26555-0136.

The testing reported herein was accomplished under contract DTNH22-14-D-00332. The task order is entitled, "New Car Assessment Program (NCAP) Non-Destructive Vehicle Testing and Data Gathering."

Section II VEHICLE PREPARATION

A. TEST VEHICLE

The test vehicle was new or in as-new condition, meaning the vehicle had been driven no more than 500 miles prior to the start of dynamic rollover testing. It was acquired through a commercial rental/leasing company. Details of the test vehicle are given in Table 1.

B. TIRES

All tires used were new, and of the same make, model, size, and DOT specification of those installed on the vehicle when purchased new. Tire inflation pressures were in accordance with the recommendations indicated on each vehicle's identification placard. To reduce the possibility of tire debanding during Fishhook testing, an appropriately sized inner tube was installed in each tire. To further reduce the possibility of tire debanding, the tires were mounted to the rims without the use of tire mounting lubricant. Tire specifications are listed in Table 2.

C. VEHICLE LOADING

The multi-passenger load, described in the Fishhook Procedure, was used for all tests. The load and positioning of the load in the vehicle are listed in Table 3.

In addition to water dummies, the loading included instrumentation, a steering machine, and outriggers. Test vehicle bumper assemblies were removed for outrigger installation. The reduction in vehicle weight due to the removal of the bumpers was offset by the additional weight of the outriggers and their mounting system. The outrigger system typically outweighs the bumper assemblies.

Table 1. Test Vehicle Data

General Data					
Model year, make, model	2018 Jeep Compass FWD				
VIN	3C4NJCBB5JT12xxxx				
Body style	SUV				
Number of doors	4				
Trim level	LATITUDE				
Seating positions	Front:	2 nd row	3 rd row	4 th row	5 th row
	2	3			
Electronic stability control	Yes				
4-Wheel ABS (Yes/No)	Yes				
Power steering (Yes/No)	Yes				
Major optional equipment	CUSTOMER PREFERRED PACKAGE 28J				
Odometer at start of testing	49 miles				
Drivetrain					
Engine cylinder arrangement	Inline 4				
Engine displacement	2.4 L				
Transmission type	Automatic				
Drive arrangement	FWD				
Chassis					
Track width	F: 60.7 in (1541.8 mm) , R: 60.3 in (1531.6 mm)				
Wheelbase	103.8 in (2636.5 mm)				
Curb weight	3311 lb (1501.8 kg)				
Certification Data from Vehicle's Label					
Vehicle manufactured by	FCA US LLC				
Date of manufacture	07/17				
GVWR	4400 lb (1996 kg)				
GAWR Front	2370 lb (1076 kg)				
GAWR Rear	2045 lb (928 kg)				

Table 2. Tire Information

Tire Manufacturer	FIRESTONE
Tire Model	DESTINATION LE2
Tire Size	Front: 225/60R17 Rear: 225/60R17
Load rating	Front: 99 Rear: 99
Speed rating	Front: T Rear: T
Treadwear grade	Front: 520 Rear: 520
Traction grade	Front: A Rear: A
Temperature grade	Front: B Rear: B
Location of "Recommended Tire Pressure" label	Driver's door jamb
Recommended cold tire pressure	Front: 35 psi, (240 kPa) Rear: 32 psi, (220 kPa)
First 8 digits of DOT code	Front: V641 DE3 Rear: V641 DE3

Table 3. Vehicle Loading

Water dummy and other loading	3 water dummies in second row
Water dummy weight	175 lb (79.4 kg)
Fuel level	Full
Weight as Tested	
Left front	1231 lb (558.4 kg)
Right front	1149 lb (521.2 kg)
Left rear	979 lb (444.1 kg)
Right rear	969 lb (439.5 kg)

D. STEERING CONTROLLER

Precise controlled steering is accomplished using a steering machine designed and constructed by DRI. DRI has used its Automated Vehicle Controller (AVC) steering machine for many vehicle tests including FMVSS 126 tests. It can provide up to 65 ft-lb torque and rates over 1300 deg/sec. The integrated angle encoder has an unlimited range with a resolution of 0.045 degrees and an accuracy of ± 0.045 degrees. The steering motor is controlled by a MicroAutoBox II from dSPACE which also acts as the data acquisition system.

E. REAL-TIME CONTROLLER AND DATA ACQUISITION

Data acquisition is achieved using a MicroAutoBox II from dSPACE which also serves as the real-time system for the steering controller. Data from the Oxford IMU, including Longitudinal, Lateral, and Vertical Acceleration, Roll, Yaw, and Pitch Rate, Forward and Lateral Velocity, Roll and Pitch Angle are sent over Ethernet to the Micro AutoBox. The Oxford IMUs are calibrated per the manufacturer's recommended schedule (Table 4). The MicroAutoBox II specifications are:

Model: D-Space Micro-Autobox II 1401/1513
Base Board SN 549068
I/O Board SN 588523

A list of the sensors is given in Table 4.

Two video cameras were used to record the Fishhook runs. They were positioned nominally as shown in Figure 1. The recorded videotapes were reviewed after the Fishhook runs to check for any two wheel lift. If any two wheel lift was observed, eight infrared distance measuring sensors for measurement of wheel lift (two sensors at each wheel) were then mounted for use in subsequent confirmation Fishhook tests.

F. OTHER VEHICLE PREPARATION

In addition to installation and preparation discussed above, the test vehicle was prepared as follows:

- Front and rear bumpers were removed
- Outrigger mounts were installed in the bumper locations and titanium outriggers were fastened to these mounts
- A five point safety harness was installed.
- Airbags were removed or otherwise disabled

Photographs of the vehicle tested are given in Appendix A.

Table 4. Sensors

Measured Variable	Sensor	Range	Resolution	Accuracy	Specifics	Serial Number	Calibration
Vehicle Tire Pressure	Tire Pressure Gauge	0-100 psi 0-690 kPa	0.01 psi 6.89 kPa	< 1% error between 20 and 100 psi	Omega DPG8001	17042707002	By: DRI Date: 6/8/2017 Due: 6/8/2018
Vehicle Total, Wheel, and Axle Load	Platform Scales (Minter)	1200 lb/platform 5338 N/platform	1 lb 4.4 N	0.5% of applied load	Intercomp SWI	1110M206352	By: DRI Date: 12/13/2016 Due: 12/13/2017
	Platform Scales (Torrance)	7000 lb 31.1 kN 31.1 kN	0.5 lb 2.2 N 2.2 N	±0.1% of applied load	Proform 67644	VS800W16- 00455	By: DRI Date: 6/1/2017 Due: 6/1/2018
Handwheel Angle	Steering Angle Encoder (Automated Steering Controller)	±800 deg	0.25 deg	±0.25 deg	DRI Automatic Vehicle Controller using D-Space Micro- Autobox II	NA	Verified by DRI at installation ¹
Longitudinal, Lateral, and Vertical Acceleration Roll, Yaw, and Pitch Rate, Forward and Lateral Velocity, Roll and Pitch Angle	Multi-Axis Inertial Sensing System	Accels ± 10g, Angular Rate ±100 deg/s, Angle >45 deg, Velocity >200 km/h	Accels ± 10g, Angular Rate ±100 deg/s, Angle >45 deg, Velocity >200 km/h	Accels ± 10g, Angular Rate ±100 deg/s, Angle >45 deg, Velocity >200 km/h	Oxford Inertial +	2258	By: Oxford Technical Solutions Date: 3/8/2017 Due: 3/8/2019

1 . The steering encoder is checked prior to beginning tests to verify that there are no faults. The steering controller is installed in the vehicle and the steering wheel is turned through two complete revolutions while recording data. The data are then reviewed for any dropouts or other nonlinearities that would indicate dust intrusion or faulty sectors.

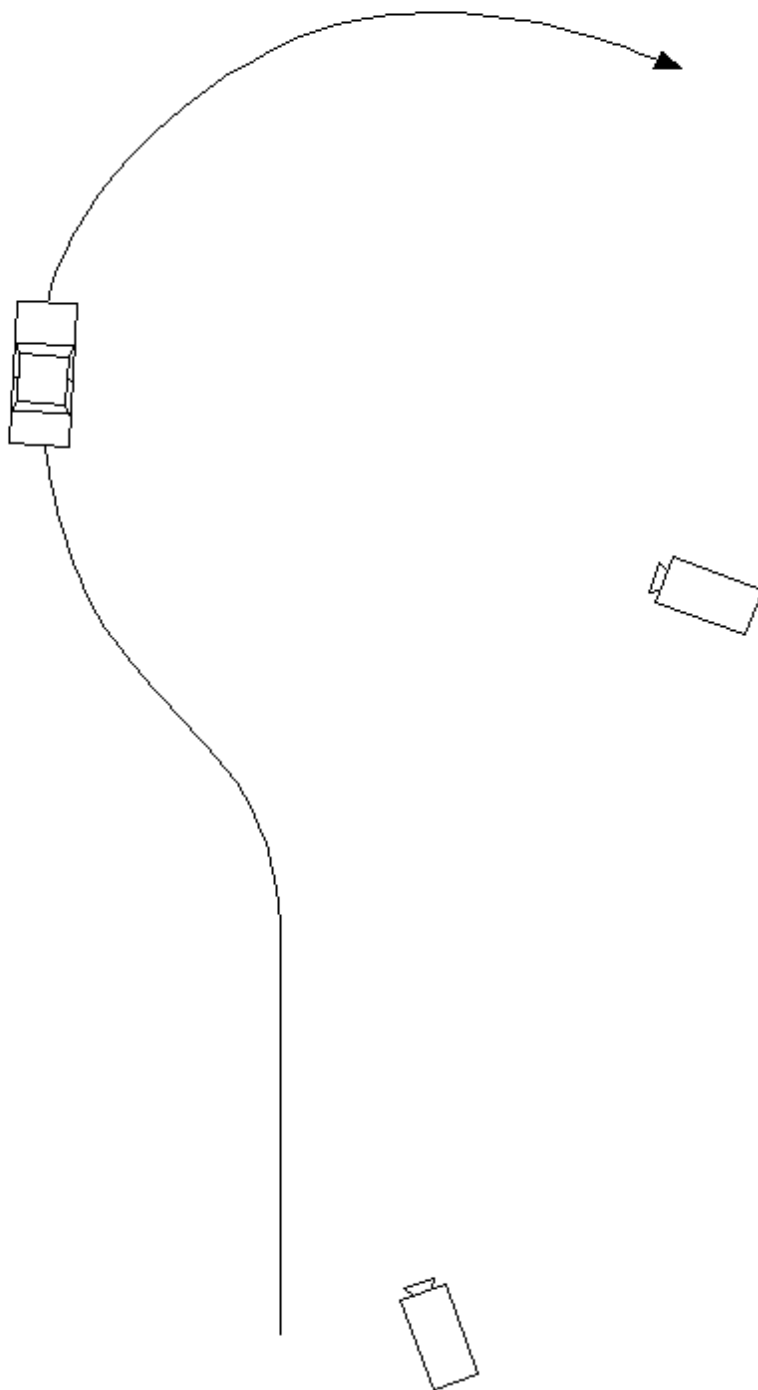

Figure 1. Nominal Position of Video Cameras for Fishhook Tests

Section III TEST PROCEDURES

This section includes a general overview of the test procedures and details of the particular test.

A. TEST PROCEDURE OVERVIEW

This test was conducted in accordance with NHTSA's NCAP Rollover Resistance Test Procedure (Fishhook) as described in the Federal Register (68 FR 59250). Detailed descriptions of the test procedure, pass/fail criteria, and data acquisition specifications may be found at docket NHTSA-2001-9663.

There are two major components of the test procedure, the Slowly Increasing Steer (SIS) pre-test and the Fishhook test.

The Slowly Increasing Steer (SIS) maneuver was used to characterize the steady state lateral dynamics of each vehicle, and is based on the "Constant Speed, Variable Steer" test defined in SAE J266. The maneuver is used to determine the handwheel angle that produces a lateral acceleration of 0.3 g at 50 mph. This handwheel angle is then used to determine the magnitude of steering to be used for the NHTSA Fishhook maneuver.

SIS tests were performed at a constant speed of 50 mph. Handwheel angle was input at a rate of 13.5 deg/sec, from 0 to an angle that provided at least 0.55 g. Three tests were conducted in each direction, and the data for the six runs were averaged to obtain the handwheel angle that produced 0.3 g at 50 mph.

The Fishhook test is a programmed steering maneuver that is implemented via the steering controller. The vehicle was initially steered in one direction and then the steering was reversed. The timing, magnitude and rate of the steering were prescribed by the Fishhook Procedure.

To begin the maneuver, the vehicle was driven in a straight line at a speed slightly greater than the desired entrance speed. The driver then released the throttle. When the vehicle was at the target speed, the steering controller automatically initiated the steering maneuver. Following completion of the steering reversal the handwheel position was maintained for three seconds, and then returned to zero angle in 1 second.

The tests were conducted in both left-right and right-left directions. The “Default” test series used a handwheel angle equal to 6.5 times the handwheel angle that produced 0.3 g at 50 mph in the SIS tests, and initial vehicle speeds beginning at 35 mph and concluding up to 50 mph (if no two-wheel lift occurs). Supplemental tests were also done, as specified in the Fishhook Procedure.

B. TEST CONDITIONS

1. Test Surface

The tests were conducted on the Vehicle Dynamics Area at DRI’s Minter Field facility, located near Bakersfield, California, on 11/2/2017. The VDA has a smooth, flat (slope less than 0.5% throughout) asphaltic concrete surface. Its dimensions are as shown in Figure 2. It was built in the spring of 2005.

VDA surface friction measurements were accomplished using the DRI Mobile Tire Tester. Three runs were done, one at each of three previously determined locations. Each run provided for a minimum of 3 seconds of tire friction at constant normal load, slip angle, and speed in a free rolling condition. The test was accomplished using an ASTM E1136 tire with an inflation pressure of 35 (± 0.5) psi at a test speed of 40 (± 0.5) mph. The net slip angle of the test tire for each test run was 7.5 deg. The test tire was no older than 6 months from the date of manufacture. The surface friction measurement results are shown in Table 5.

Table 5. Surface Friction

Date of surface friction measurements	11/2/2017
Average normalized lateral force	0.871

2. Fishhook Handwheel Angles

The 0.3 g handwheel angle obtained from the SIS tests and the handwheel angles used in the Fishhook tests are shown in Table 6.

Table 6. Handwheel Angles

0.3 g handwheel angle (from SIS tests at 50 mph)	28.1 °
5.5 scalar handwheel angle for Fishhook Test	155°
6.5 scalar handwheel angle for Fishhook Test	183 °

3. Weather Conditions

The weather conditions, recorded at the end of testing, are shown in Table 7.

Table 7. Weather Conditions

Ambient temperature	57 °F (13.9 °C)
Wind Speed	0 mph (0 m/s)
Wind Direction	N

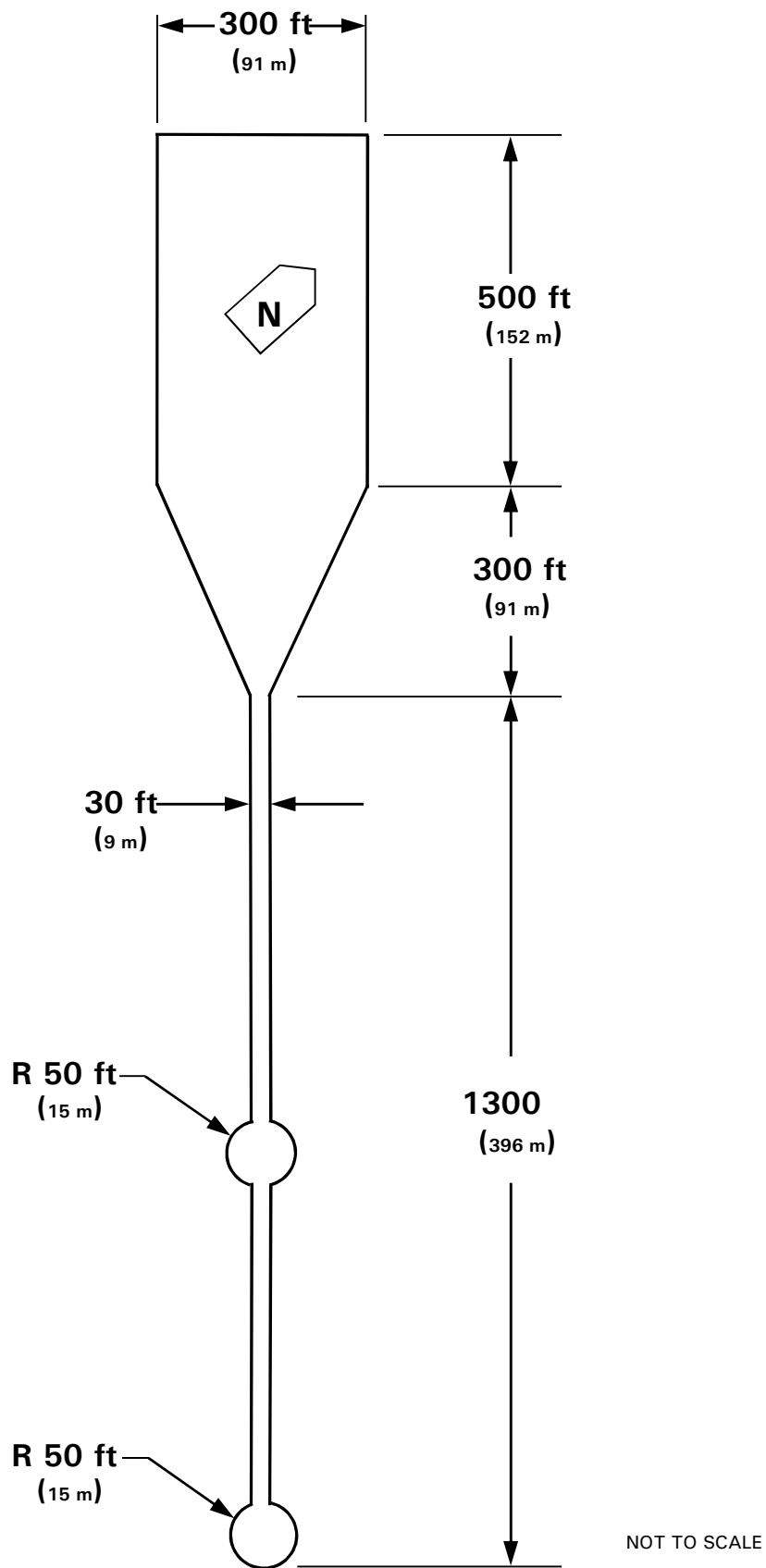

Figure 2. DRI-Minter Vehicle Dynamics Area

Section IV RESULTS

The test run log is given in Appendix B. The Slowly Increasing Steer Test Worksheet is given in Appendix C. Appendix D contains time history plots for the 50 mph runs and any runs which resulted in two-wheel lift. For the 2018 Jeep Compass FWD, there was no two-wheel lift at any test condition.

APPENDIX A

Photographs

LIST OF FIGURES

	Page
A1. Window Sticker	A-3
A2. Front View, Test Vehicle as Delivered	A-4
A3. Rear View, Test Vehicle as Delivered	A-5
A4. Front View, Test Vehicle in Test Condition	A-6
A5. Rear View, Test Vehicle in Test Condition	A-7
A6. Instrumentation in Test Vehicle	A-8
A7. Steering Controller and Computer	A-9
A8. Ballast Condition.....	A-10

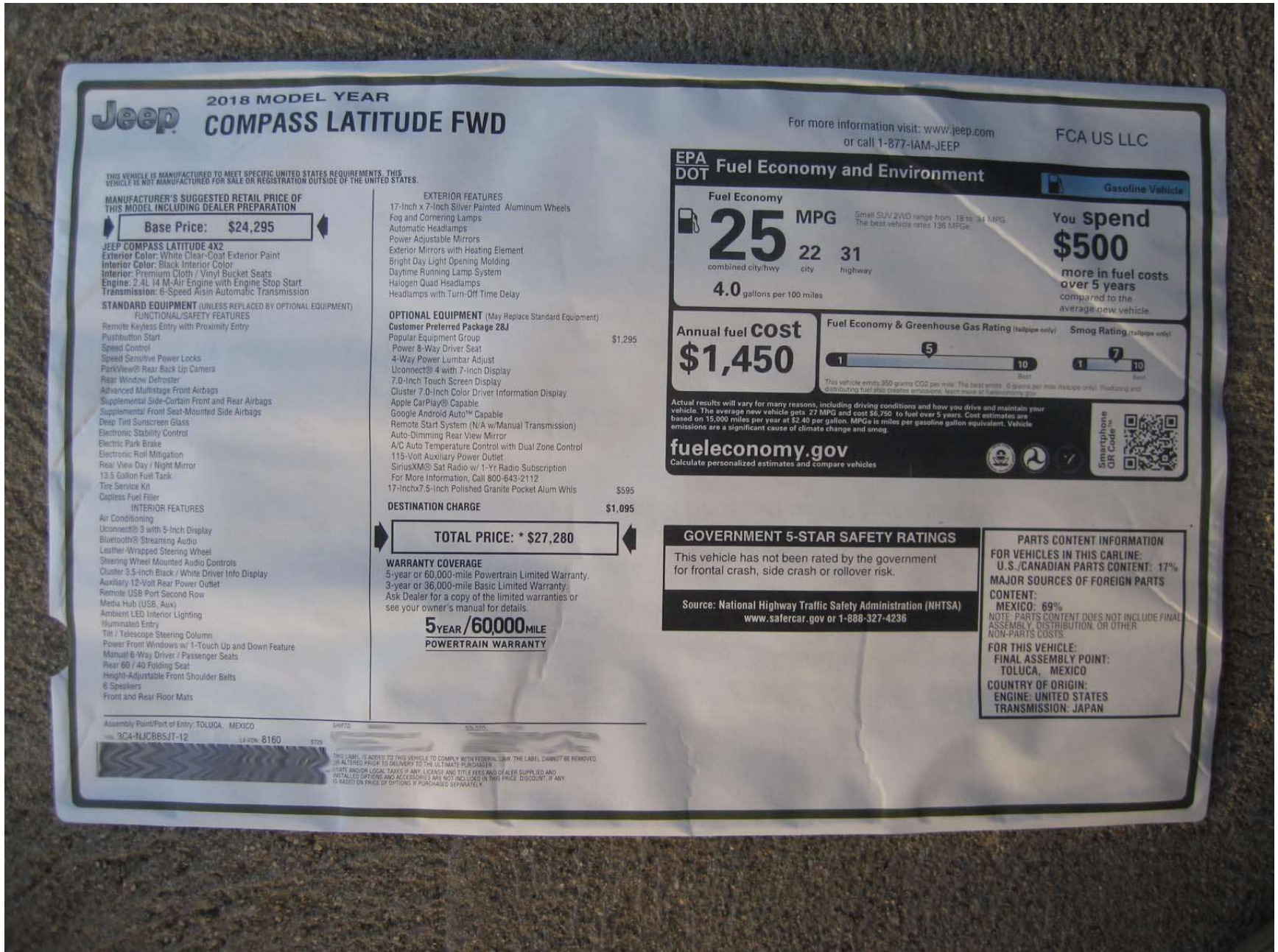

Jeep 2018 MODEL YEAR
COMPASS LATITUDE FWD

THIS VEHICLE IS MANUFACTURED TO MEET SPECIFIC UNITED STATES REQUIREMENTS. THIS VEHICLE IS NOT MANUFACTURED FOR SALE OR REGISTRATION OUTSIDE OF THE UNITED STATES.

MANUFACTURER'S SUGGESTED RETAIL PRICE OF THIS MODEL INCLUDING DEALER PREPARATION

Base Price: \$24,295

JEEP COMPASS LATITUDE 4X2
 Exterior Color: White Clear-Coat Exterior Paint
 Interior Color: Black Interior Color
 Interior: Premium Cloth / Vinyl Bucket Seats
 Engine: 2.4L I4 M-Air Engine with Engine Stop Start
 Transmission: 6-Speed Aisin Automatic Transmission

STANDARD EQUIPMENT (UNLESS REPLACED BY OPTIONAL EQUIPMENT)
 FUNCTIONAL/SAFETY FEATURES

- Remote Keyless Entry with Proximity Entry
- Pushbutton Start
- Speed Control
- Speed Sensitive Power Locks
- ParkView® Rear Back Up Camera
- Rear Window Defroster
- Advanced Multistage Front Airbags
- Supplemental Side-Curtain Front and Rear Airbags
- Supplemental Front Seat-Mounted Side Airbags
- Deep Tint Sunscreen Glass
- Electronic Stability Control
- Electric Park Brake
- Electronic Roll Mitigation
- Rear View Day / Night Mirror
- 13.5 Gallon Fuel Tank
- Tire Service Kit
- Capless Fuel Filler

INTERIOR FEATURES

- Air Conditioning
- Uconnect® 3 with 5-Inch Display
- Bluetooth® Streaming Audio
- Leather-Wrapped Steering Wheel
- Steering Wheel Mounted Audio Controls
- Cluster 3.5-Inch Black / White Driver Info Display
- Auxiliary 12-Volt Rear Power Outlet
- Remote USB Port Second Row Media Hub (USB, Aux)
- Ambient LED Interior Lighting
- Illuminated Entry
- Tilt / Telescope Steering Column
- Power Front Windows w/ 1-Touch Up and Down Feature
- Manual 6-Way Driver / Passenger Seats
- Rear 60 / 40 Folding Seat
- Height-Adjustable Front Shoulder Belts
- 6 Speakers
- Front and Rear Floor Mats

EXTERIOR FEATURES

- 17-Inch x 7-Inch Silver Painted Aluminum Wheels
- Fog and Cornering Lamps
- Automatic Headlamps
- Power Adjustable Mirrors
- Exterior Mirrors with Heating Element
- Bright Day Light Opening Molding
- Daytime Running Lamp System
- Halogen Quad Headlamps
- Headlamps with Turn-Off Time Delay

OPTIONAL EQUIPMENT (May Replace Standard Equipment)

- Customer Preferred Package 28J** \$1,295
 - Popular Equipment Group
 - Power 8-Way Driver Seat
 - 4-Way Power Lumbar Adjust
 - Uconnect® 4 with 7-Inch Display
 - 7.0-Inch Touch Screen Display
 - Cluster 7.0-Inch Color Driver Information Display
 - Apple CarPlay® Capable
 - Google Android Auto™ Capable
 - Remote Start System (N/A w/Manual Transmission)
 - Auto-Dimming Rear View Mirror
 - A/C Auto Temperature Control with Dual Zone Control
 - 115-Volt Auxiliary Power Outlet
 - SiriusXM® Sat Radio w/ 1-Yr Radio Subscription
 - For More Information, Call 800-643-2112
 - 17-Inch x 7.5-Inch Polished Granite Pocket Alum Whis \$595

DESTINATION CHARGE \$1,095

TOTAL PRICE: * \$27,280

WARRANTY COVERAGE

- 5-year or 60,000-mile Powertrain Limited Warranty.
- 3-year or 36,000-mile Basic Limited Warranty.
- Ask Dealer for a copy of the limited warranties or see your owner's manual for details.

**5 YEAR / 60,000 MILE
POWERTRAIN WARRANTY**

Assembly Plant/Port of Entry: TOLUCA, MEXICO
 VIN: 3C4AJCB85JT-12 LEAD: 8160 6759

THIS LABEL IS ADDED TO THIS VEHICLE TO COMPLY WITH FEDERAL LAW. THE LABEL CANNOT BE REMOVED OR ALTERED PRIOR TO DELIVERY TO THE ULTIMATE PURCHASER.
 *TAXES AND/OR LOCAL TAXES IF ANY, LICENSE AND TITLE FEES AND DEALER SUPPLIED AND INSTALLED OPTIONS AND ACCESSORIES ARE NOT INCLUDED IN THIS PRICE. DISCOUNT, IF ANY, IS BASED ON PRICE OF OPTIONS IF PURCHASED SEPARATELY.

For more information visit: www.jeep.com
 or call 1-877-IAM-JEEP

FCA US LLC

EPA DOT Fuel Economy and Environment

Fuel Economy
25 MPG
combined city/hwy
22 MPG
city
31 MPG
highway
4.0 gallons per 100 miles

Small SUV 2WD range from 18 to 34 MPG. The best vehicle rates 156 MPGe.

Gasoline Vehicle

You spend \$500 more in fuel costs over 5 years
compared to the average new vehicle.

Annual fuel cost \$1,450

Fuel Economy & Greenhouse Gas Rating (multiple only)



Smog Rating (multiple only)

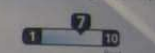

This vehicle emits 350 grams CO2 per mile. The best emits 0 grams per mile (multiple only). Producing and distributing fuel also creates emissions. Learn more at www.epa.gov

Actual results will vary for many reasons, including driving conditions and how you drive and maintain your vehicle. The average new vehicle gets 27 MPG and cost \$8,750 to fuel over 5 years. Cost estimates are based on 15,000 miles per year at \$2.40 per gallon. MPGe is miles per gasoline gallon equivalent. Vehicle emissions are a significant cause of climate change and smog.

fuel economy.gov
 Calculate personalized estimates and compare vehicles



GOVERNMENT 5-STAR SAFETY RATINGS

This vehicle has not been rated by the government for frontal crash, side crash or rollover risk.

Source: National Highway Traffic Safety Administration (NHTSA)
www.safercar.gov or 1-888-327-4236

PARTS CONTENT INFORMATION

FOR VEHICLES IN THIS CARLINE:
 U.S./CANADIAN PARTS CONTENT: 17%
MAJOR SOURCES OF FOREIGN PARTS CONTENT:

MEXICO: 69%
NOTE: PARTS CONTENT DOES NOT INCLUDE FINAL ASSEMBLY, DISTRIBUTION, OR OTHER NON-PARTS COSTS.

FOR THIS VEHICLE:
 FINAL ASSEMBLY POINT:
 TOLUCA, MEXICO
 COUNTRY OF ORIGIN:
 ENGINE: UNITED STATES
 TRANSMISSION: JAPAN



Figure A2. Front View, Test Vehicle as Delivered



Figure A3. Rear View, Test Vehicle as Delivered



Figure A4. Front View, Test Vehicle in Test Condition



Figure A5. Rear View, Test Vehicle in Test Condition



Figure A6. Instrumentation in Test Vehicle



Figure A7. Steering Controller and Computer



Figure A8. Ballast Condition

APPENDIX B

Test Run Log

Vehicle: **2018 Jeep Compass FWD**Driver: **John Partridge**Date: **11/2/2017**

Run Number	Test Type	Speed (mph)	Handwheel Angle (deg)	Dir. of First Steer	2 Wheel Lift	Notes
1	Tire Warm-Up	35	80	Right	5P	
2			80			Resulted in ay = 0.61g
3						
4						2x SWA last cycle
5	Slowly Increasing Steer	50	50	Left		Resulted in ay = 0.56g
6				Left		
7				Left		
8				Right		
9				Right		
10				Right		
11	Static					
12	Steady State					
13	Fishhook 6.5 scalar	35	183	Left	No	
14		40			No	
15		45			No	
16		47.5			No	
17		50			No	
18	Fishhook 5.5 scalar	45	155	Left	No	
19		47.5			No	
20		50			No	
21	Fishhook 6.5 scalar	35	183	Right	No	
22		40			No	
23		45			No	

Vehicle: **2018 Jeep Compass FWD**Driver: **John Partridge**Date: **11/2/2017**

Run Number	Test Type	Speed (mph)	Handwheel Angle (deg)	Dir. of First Steer	2 Wheel Lift	Notes
24		47.5			No	
25		50			No	
26	Fishhook 5.5 scalar	45	155	Right	No	
27		47.5			No	
28		50			No	

APPENDIX C

Slowly Increasing Steer Test Worksheet

NCAP, 2018 Jeep Compass FWD , Multi-Passenger Load, Test Date: 11/2/2017

SIS_out_v2

Run	Dir of Steer	Start Speed (mph)	End Speed (mph)	Speed Red. (%)	Index of ay @ 0.3g	HW Angle (deg) at 0.3g	ay (g) @ 0.3g index	6.5x HW Angle (deg)	Ramp Time (sec) at 6.5x	5.5x HW Angle (deg)	Ramp Time (sec) at 5.5x	R2	Zero Begin Index	Zero End Index
5	1	50.1	0.6	98.9	1218	-27.7	-0.291	-180.1	-0.2502	-152.4	-0.2117	0.9941	600	800
6	1	49.4	4.9	90.0	1223	-28.0	-0.303	-182.3	-0.2531	-154.2	-0.2142	0.9964	600	800
7	1	50.4	5.1	89.8	1213	-27.5	-0.306	-178.6	-0.2480	-151.1	-0.2099	0.9938	600	800
8	0	50.5	3.3	93.4	1223	28.1	0.301	182.7	0.2537	154.6	0.2147	0.9954	600	800
9	0	49.4	1.1	97.8	1230	28.5	0.31	185.4	0.2575	156.9	0.2179	0.9948	600	800
10	0	50.1	2.5	95.1	1233	28.7	0.292	186.5	0.259	157.8	0.2192	0.9942	600	800

Mean: 28.1 0.3 183 0.254 154 0.215

Steering Controller Input Values

Scalar 6.5 values:

Initial HW angle: 183 deg
Initial time: 0.254 s
Reversal HW angle: -183 deg
Reversal time: 0.507 s

Scalar 5.5 values:

Initial HW angle: 154 deg
Initial time: 0.215 s
Reversal HW angle: -154 deg
Reversal time: 0.429 s

APPENDIX D

Time History Plots

LIST OF FIGURES

	Page
D1. Vehicle Speed, Handwheel Angle, and Roll Angle Time History Plots for Default Test Series, L-R, 50 mph	D-3
D2. Steering Machine Operation Time History Plots for Default Test Series, L-R, 50 mph.....	D-4
D3. Yaw Rate, Roll Rate, and Lateral Acceleration Time History Plots for Default Test Series, L-R, 50 mph	D-5
D4. Pitch Rate and Longitudinal Acceleration Time History Plots for Default Test Series, L-R, 50 mph	D-6
D5. Vehicle Speed, Handwheel Angle, and Roll Angle Time History Plots for Default Test Series, R-L, 50 mph	D-7
D6. Steering Machine Operation Time History Plots for Default Test Series, R-L, 50 mph	D-8
D7. Yaw Rate, Roll Rate, and Lateral Acceleration Time History Plots for Default Test Series, R-L, 50 mph	D-9
D8. Pitch Rate and Longitudinal Acceleration Time History Plots for Default Test Series, R-L, 50 mph	D-10
D9. Vehicle Speed, Handwheel Angle, and Roll Angle Time History Plots for Supplemental 2 Test Series, L-R, 50 mph.....	D-11
D10. Steering Machine Operation Time History Plots for Supplemental 2 Test Series, L-R, 50 mph.....	D-12
D11. Yaw Rate, Roll Rate, and Lateral Acceleration Time History Plots for Supplemental 2 Test Series, L-R, 50 mph.....	D-13
D12. Pitch Rate and Longitudinal Acceleration Time History Plots for Supplemental 2 Test Series, L-R, 50 mph.....	D-14
D13. Vehicle Speed, Handwheel Angle, and Roll Angle Time History Plots for Supplemental 2 Test Series, R-L, 50 mph.....	D-15
D14. Steering Machine Operation Time History Plots for Supplemental 2 Test Series, R-L, 50 mph.....	D-16
D15. Yaw Rate, Roll Rate, and Lateral Acceleration Time History Plots for Supplemental 2 Test Series, R-L, 50 mph.....	D-17
D16. Pitch Rate and Longitudinal Acceleration Time History Plots for Supplemental 2 Test Series, R-L, 50 mph.....	D-18

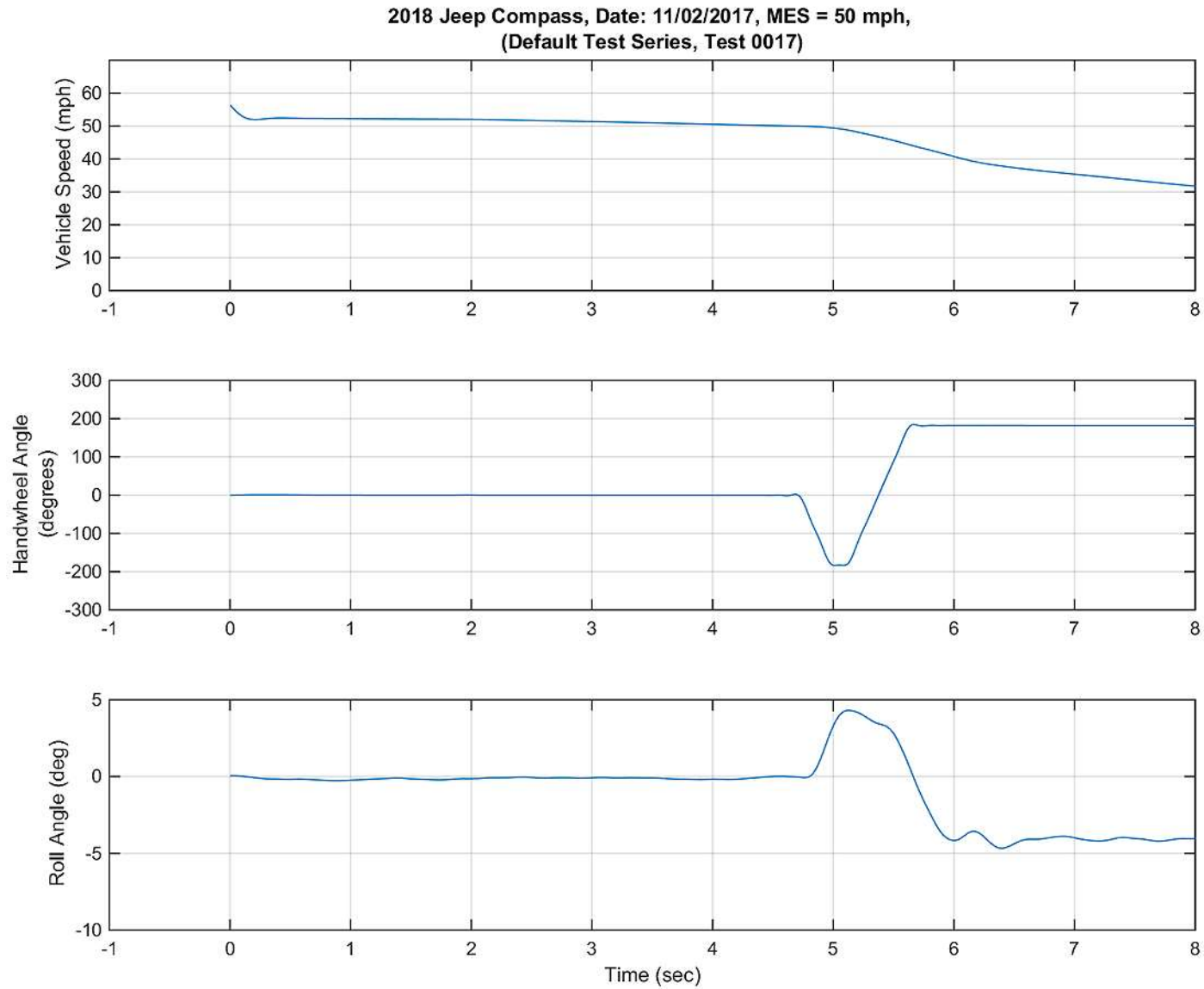

Figure D1. Vehicle Speed, Handwheel Angle, and Roll Angle Time History Plots for Default Test Series, L-R, 50 mph

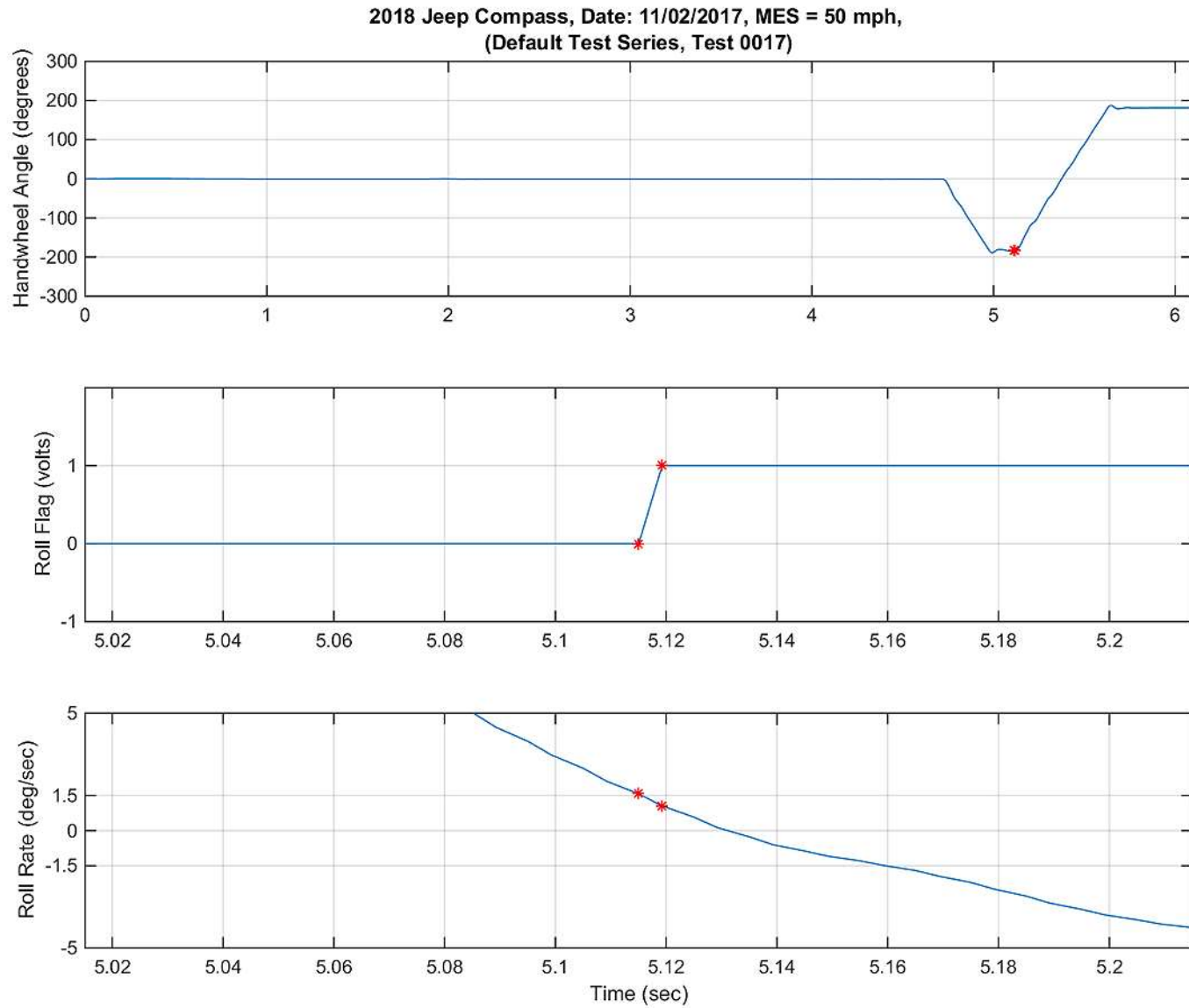

Figure D2. Steering Machine Operation Time History Plots for Default Test Series, L-R, 50 mph

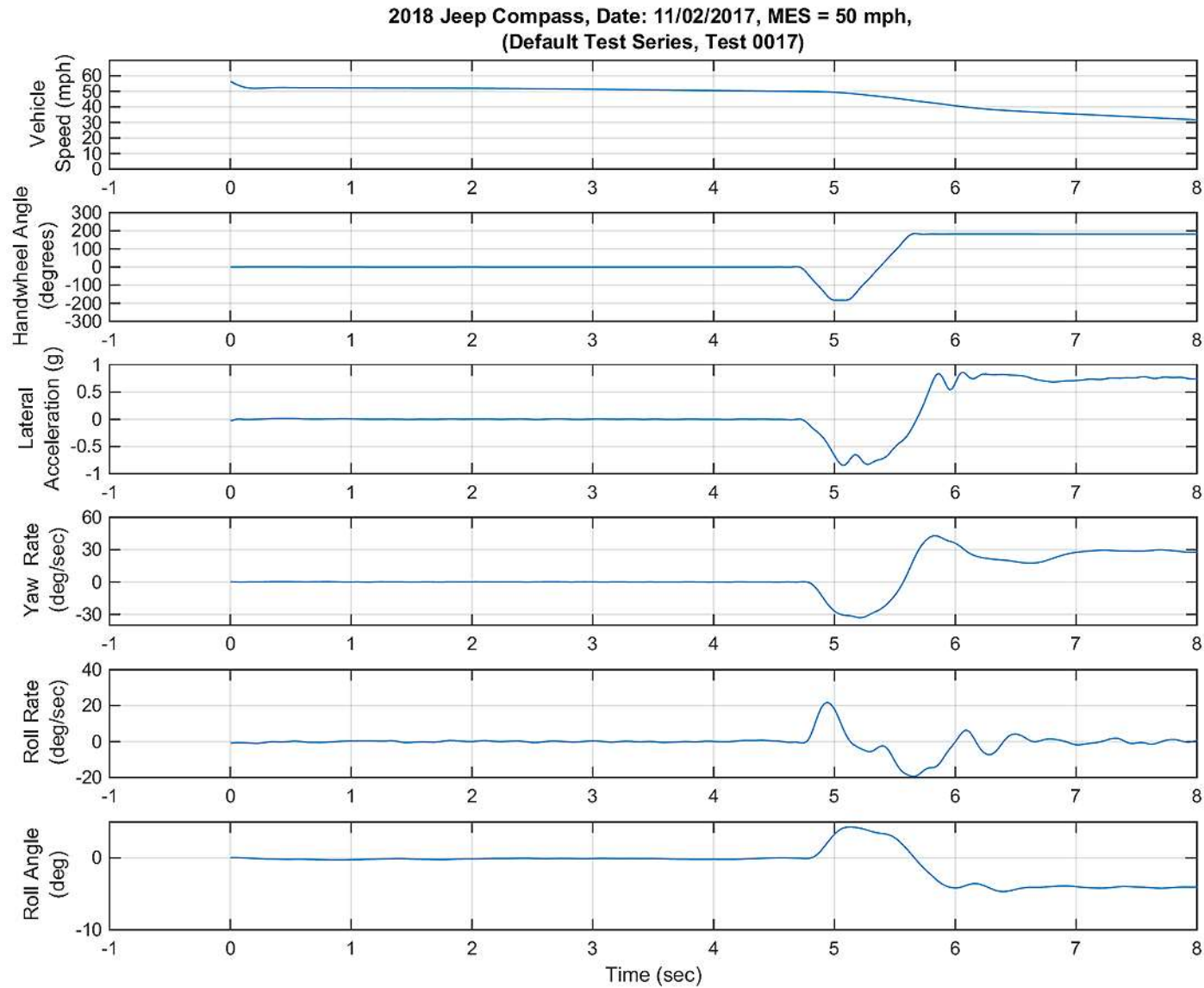

Figure D3. Yaw Rate, Roll Rate, and Lateral Acceleration Time History Plots For Default Test Series, L-R, 50 mph

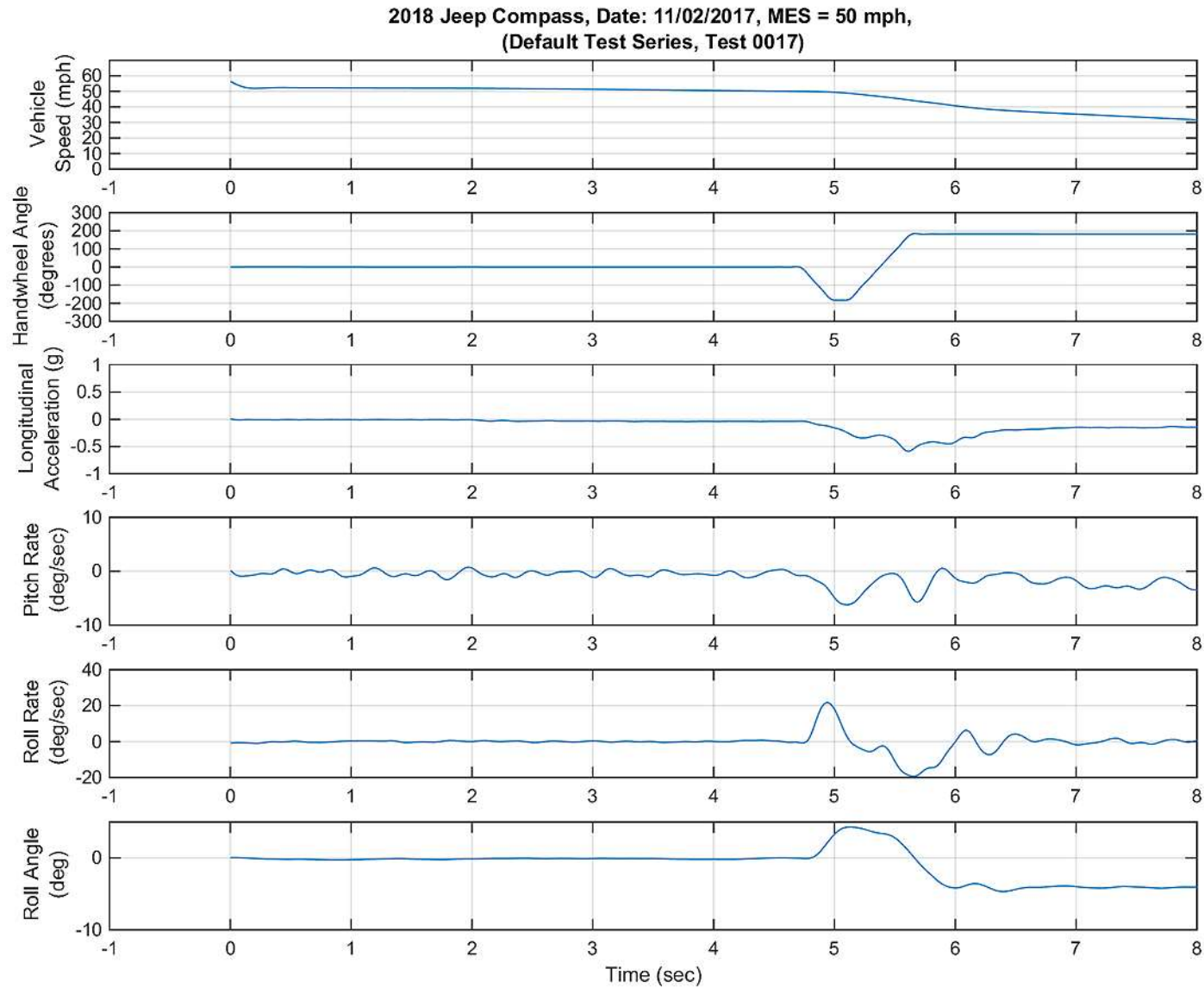

Figure D4. Pitch Rate and Longitudinal Acceleration Time History Plots for Default Test Series, L-R, 50 mph

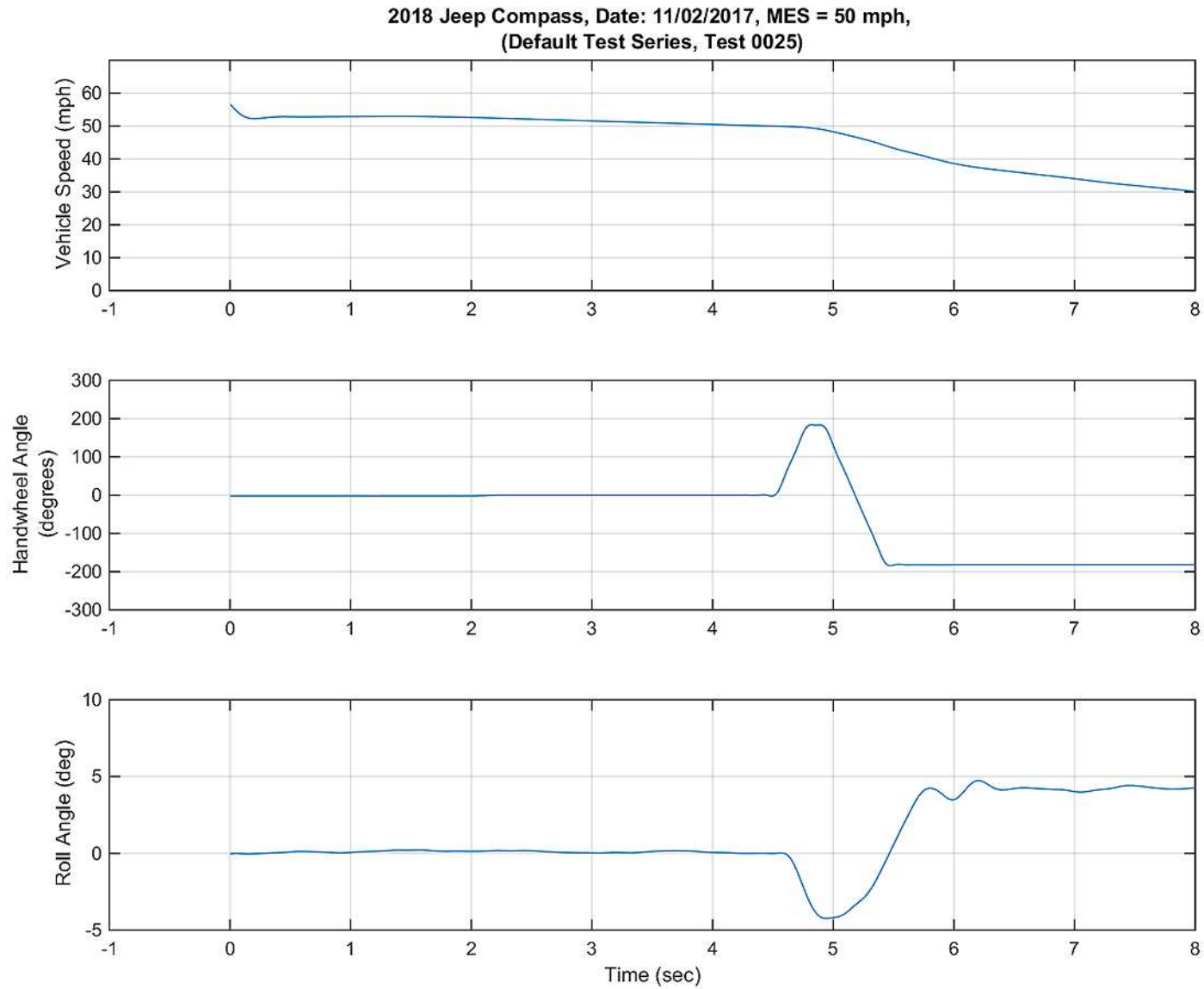

Figure D5. Vehicle Speed, Handwheel Angle, and Roll Angle Time History Plots for Default Test Series, R-L, 50 mph

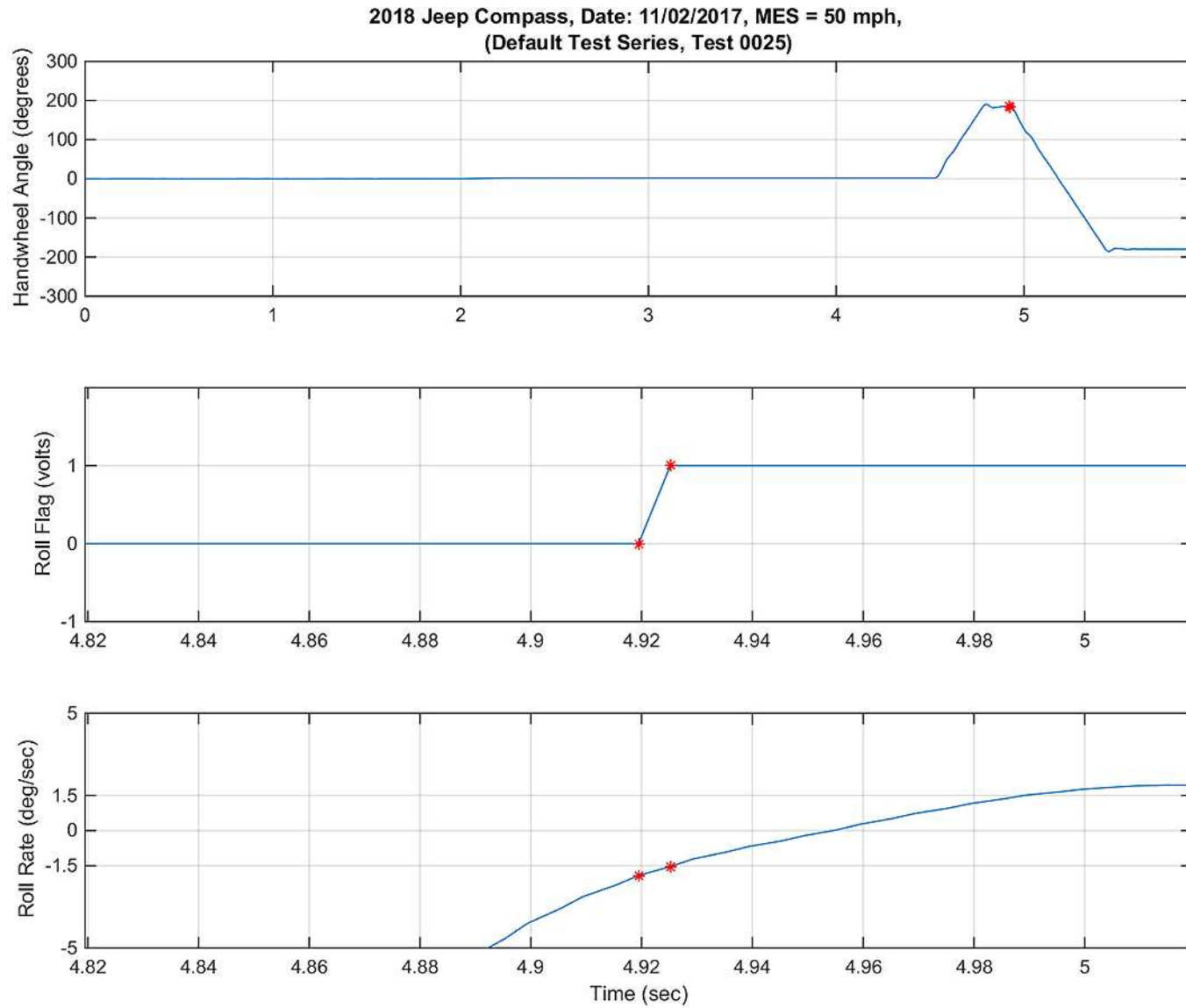

Figure D6. Steering Machine Operation Time History Plots for Default Test Series, R-L, 50 mph

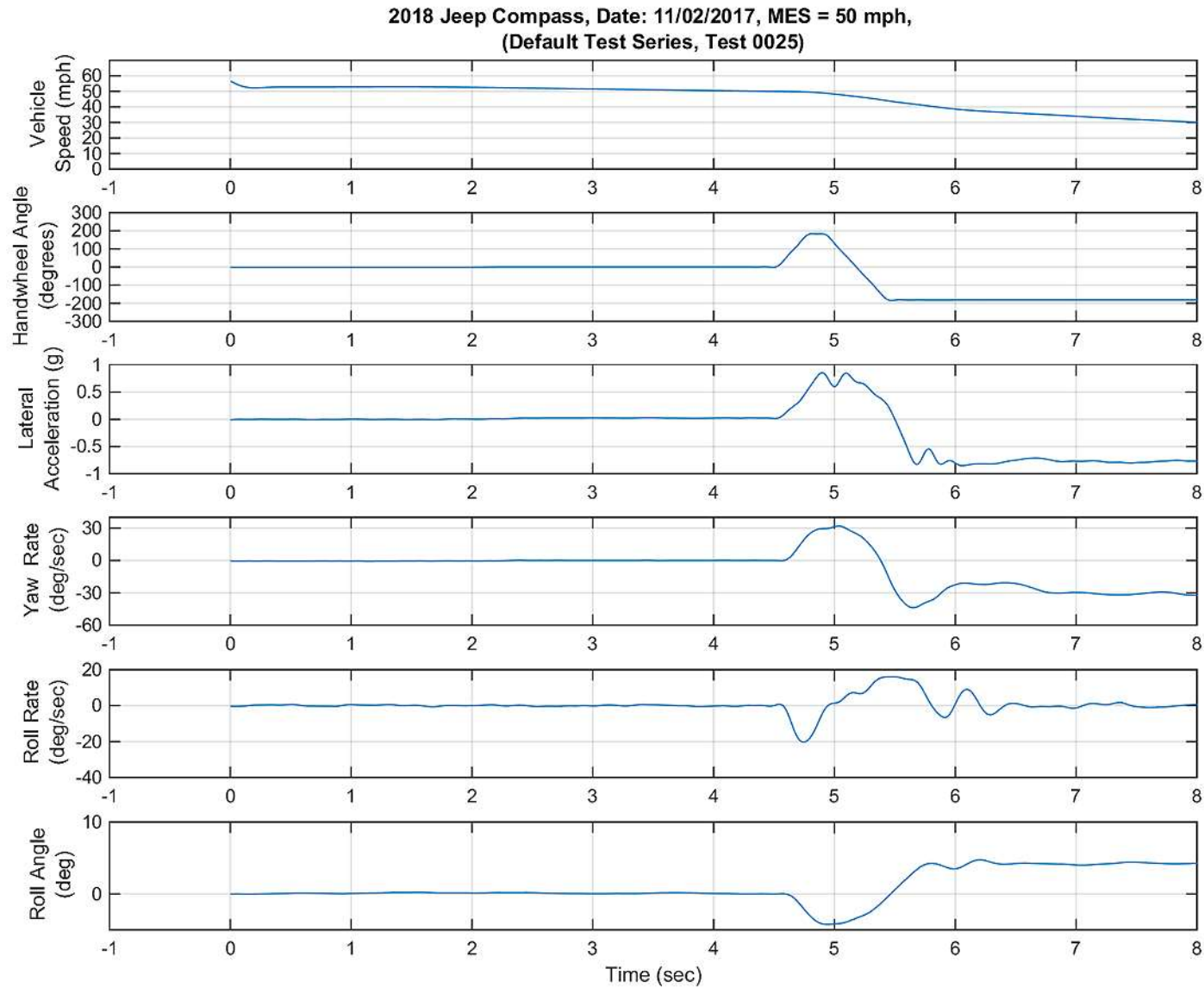

Figure D7. Yaw Rate, Roll Rate, and Lateral Acceleration Time History Plots for Default Test Series, R-L, 50 mph

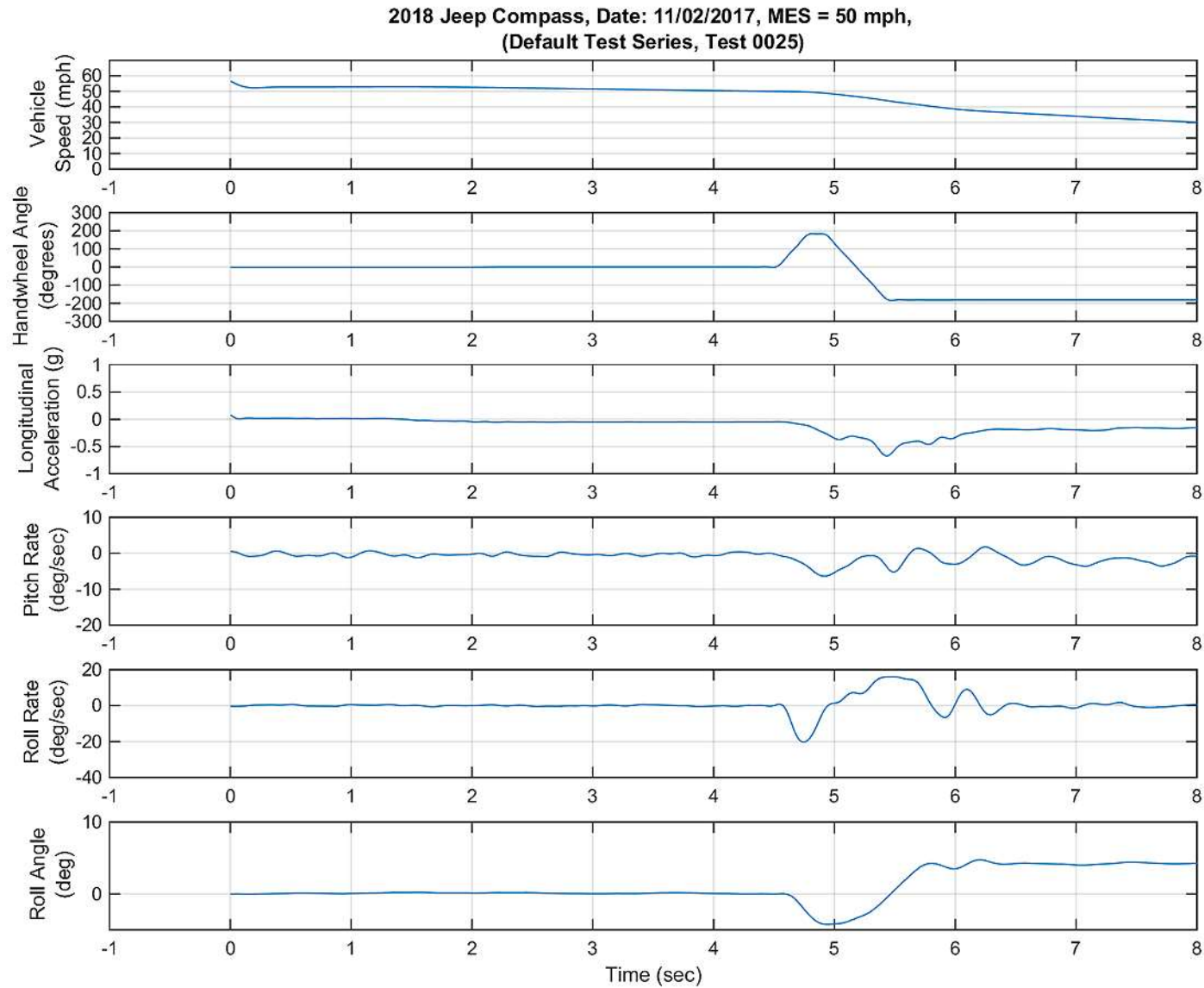

Figure D8. Pitch Rate and Longitudinal Acceleration Time History Plots or Default Test Series, R-L, 50 mph

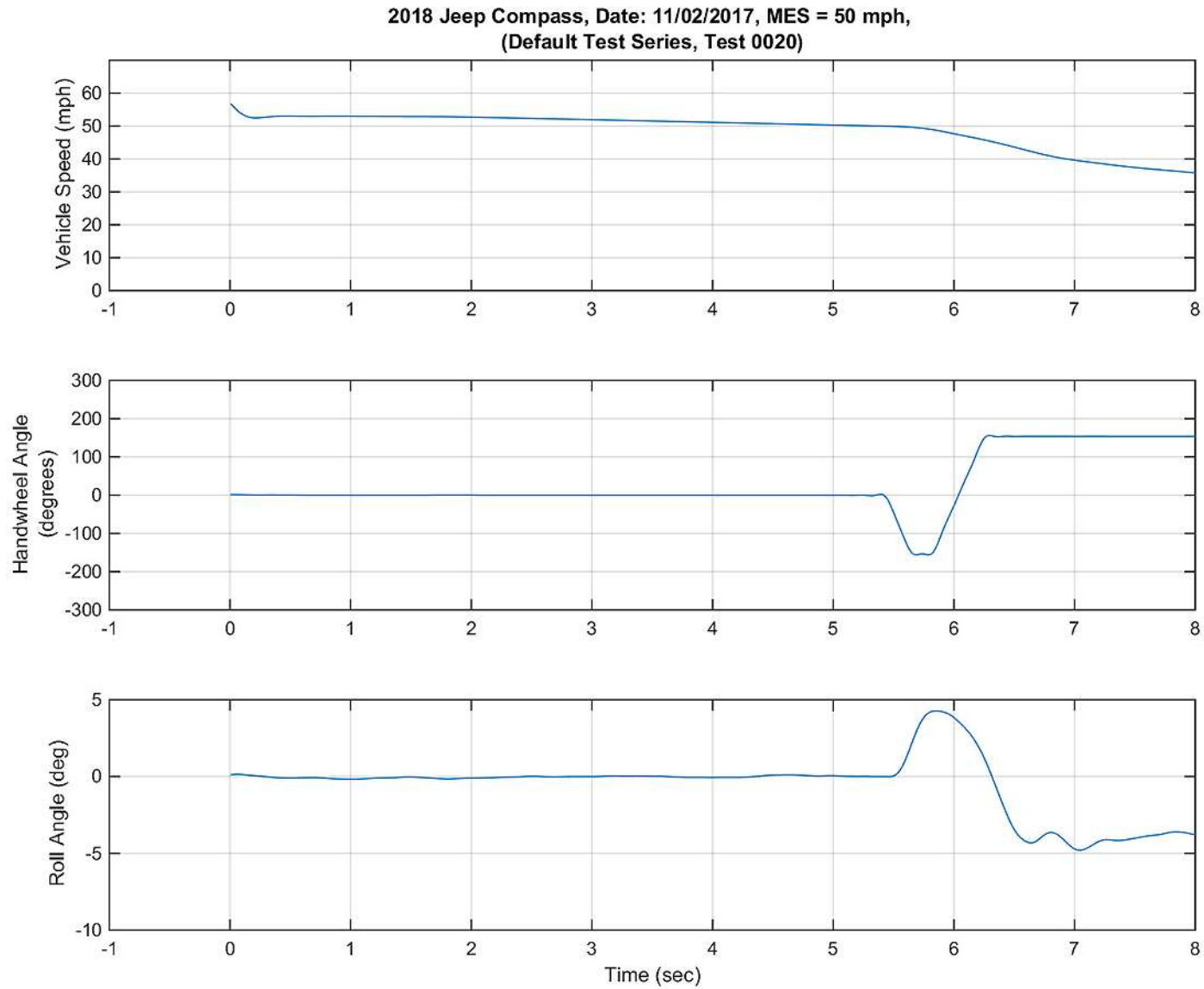

Figure D9. Vehicle Speed, Handwheel Angle, and Roll Angle Time History Plots for Supplemental 2 Test Series, L-R, 50 mph

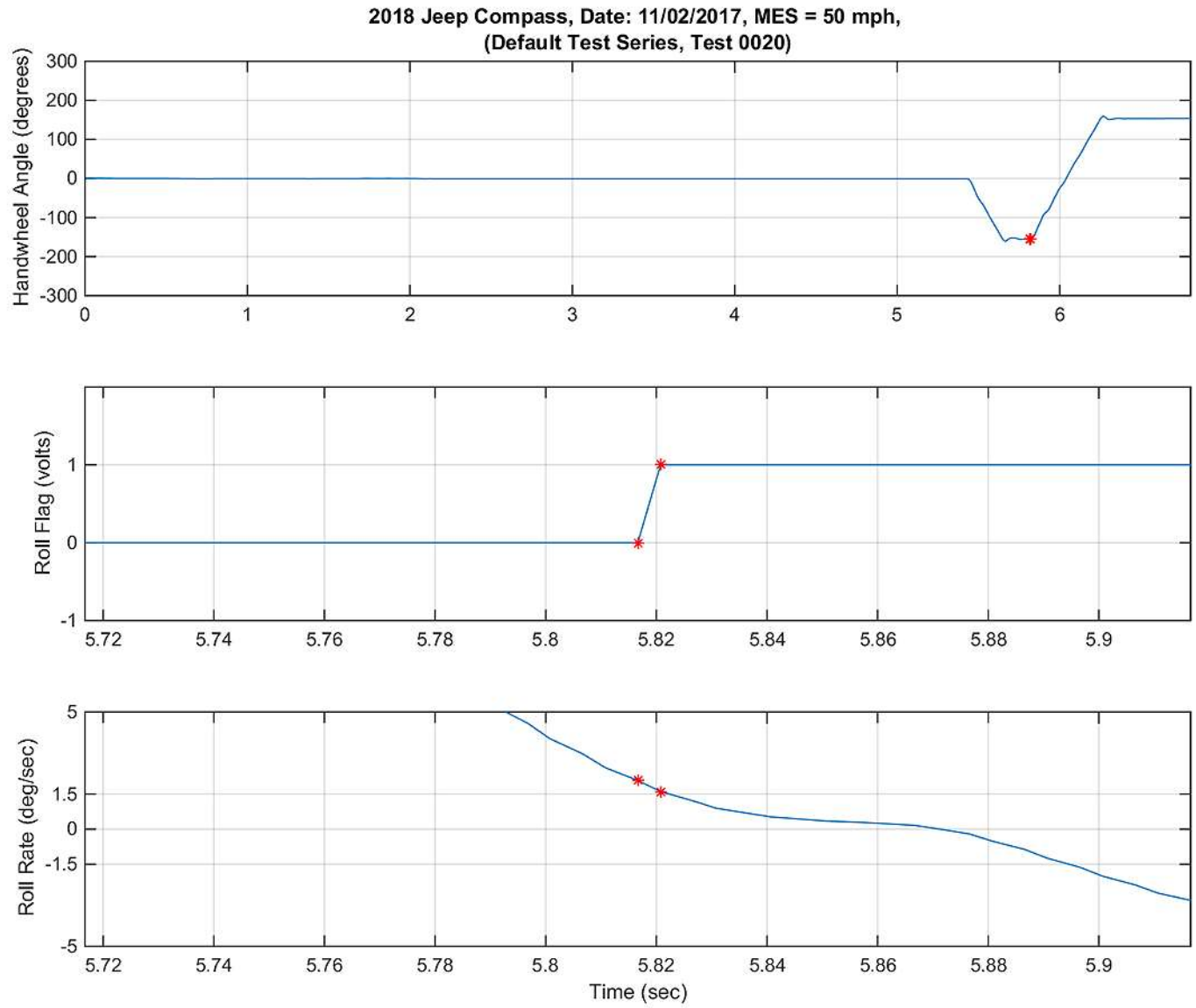

Figure D10. Steering Machine Operation Time History Plots for Supplemental 2 Test Series, L-R, 50 mph

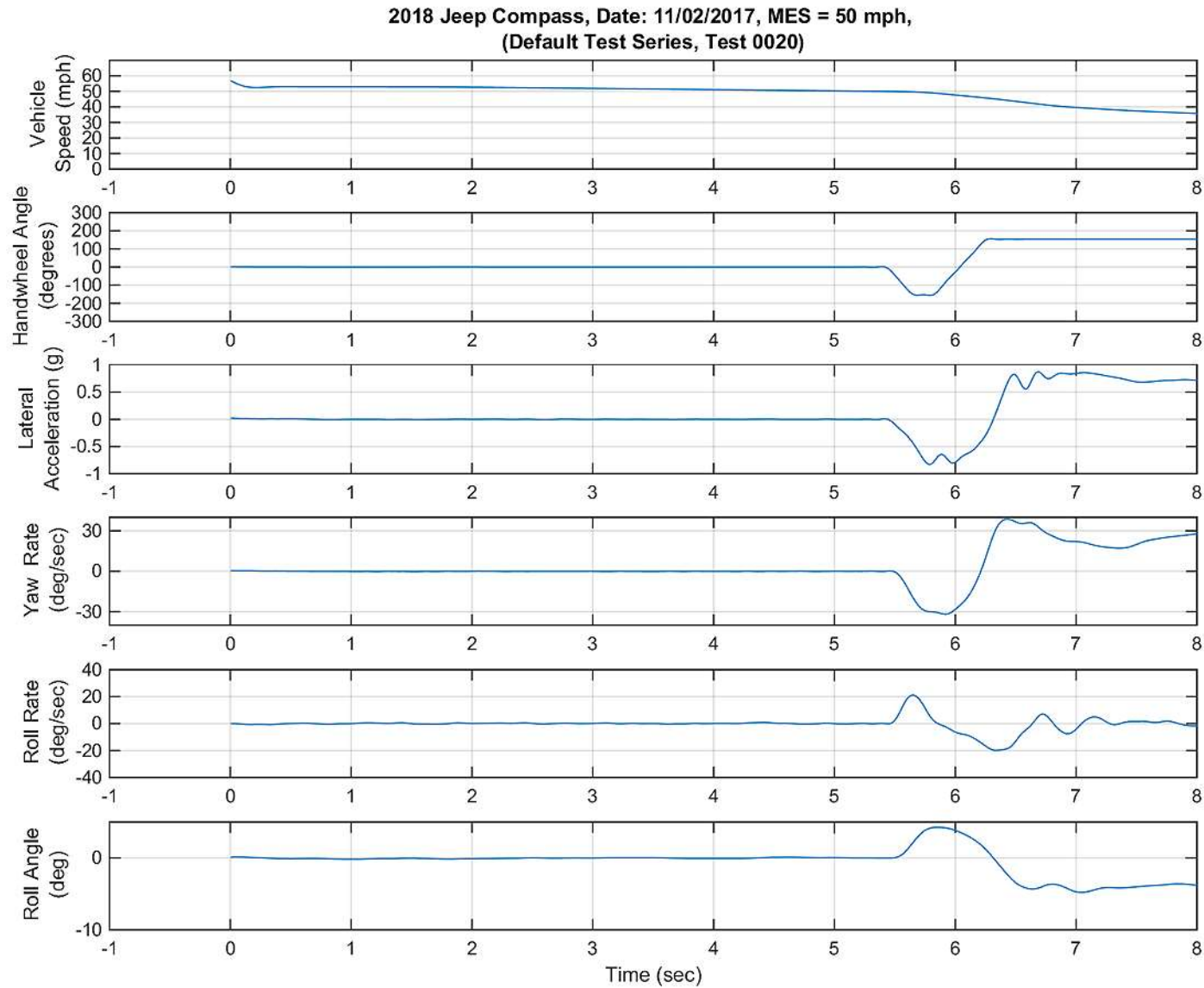

Figure D11. Yaw Rate, Roll Rate, and Lateral Acceleration Time History Plots for Supplemental 2 Test Series, L-R, 50 mph

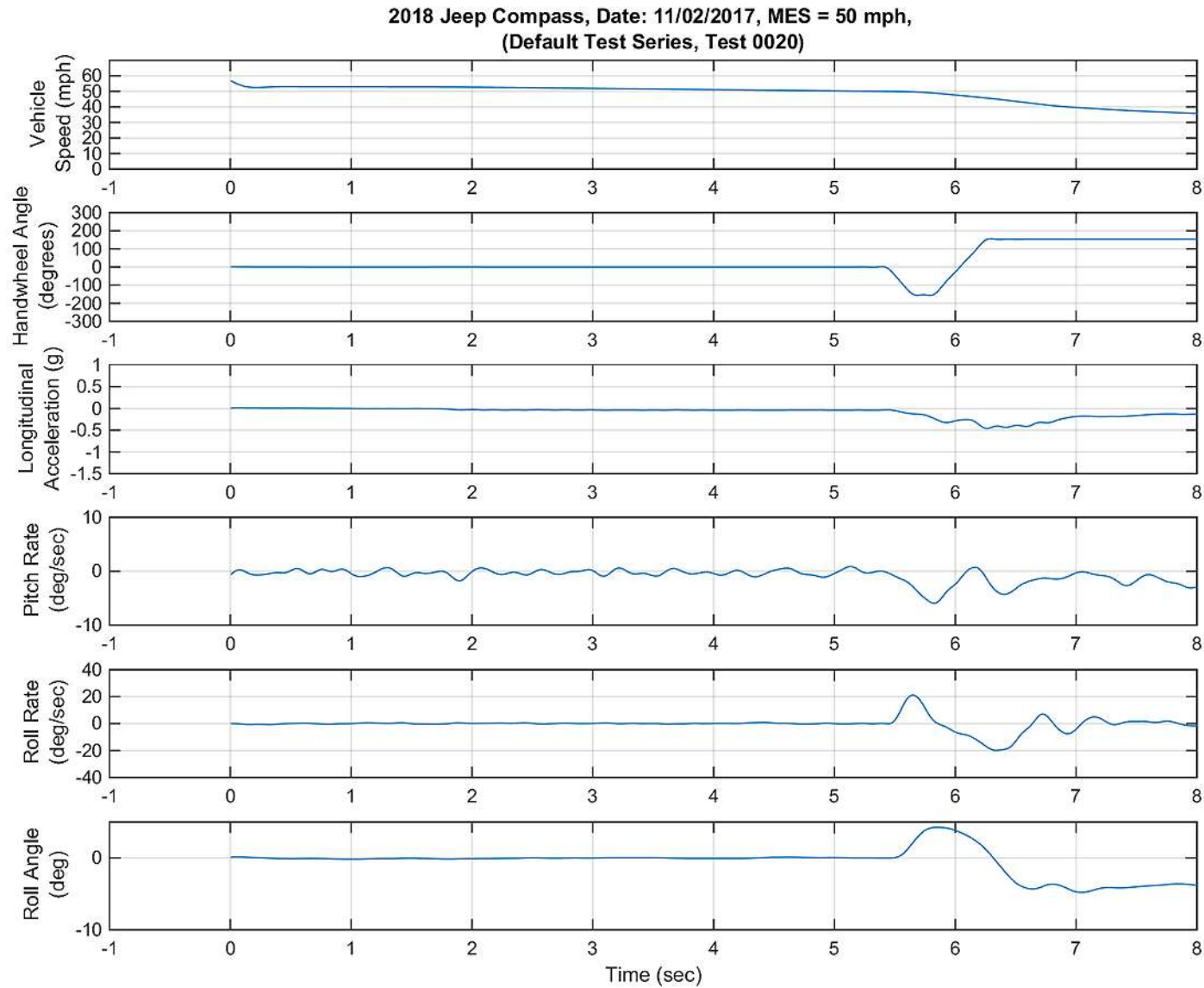

Figure D12. Pitch Rate and Longitudinal Acceleration Time History Plots for Supplemental 2 Test Series, L-R, 50 mph

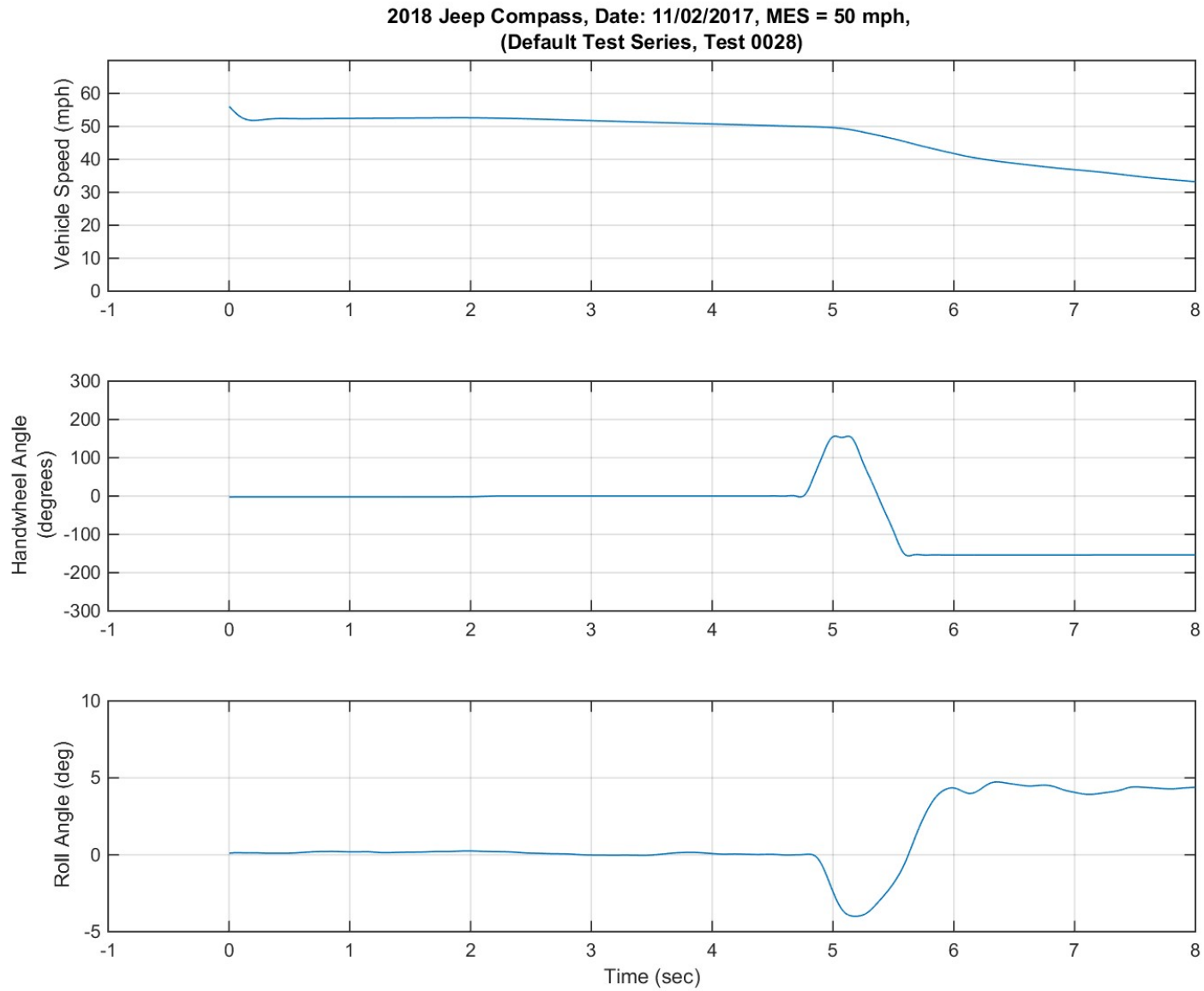

Figure D13. Vehicle Speed, Handwheel Angle, and Roll Angle Time History Plots for Supplemental 2 Test Series, R-L, 50 mph

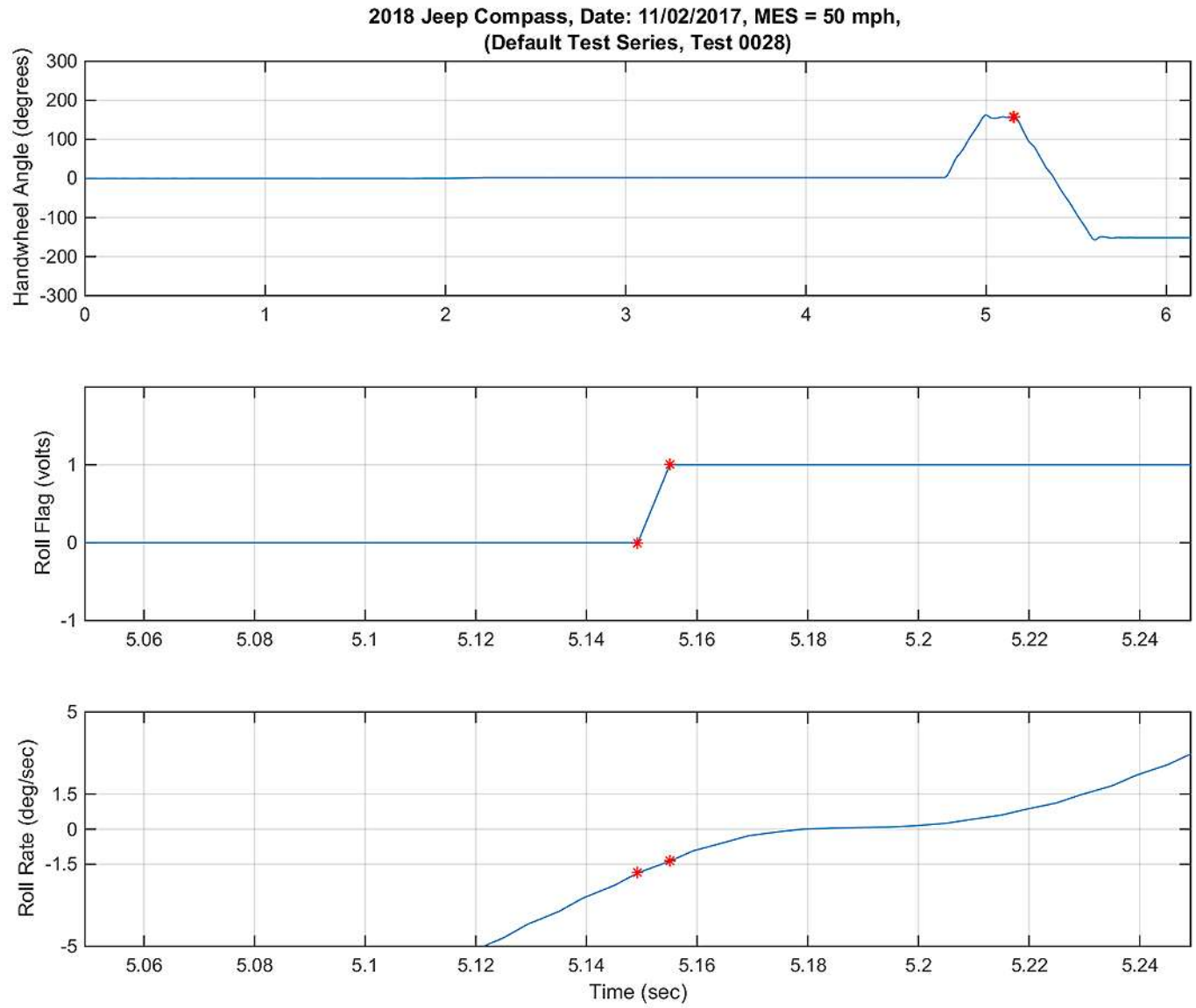

Figure D14. Steering Machine Operation Time History Plots for Supplemental 2 Test Series, R-L, 50 mph

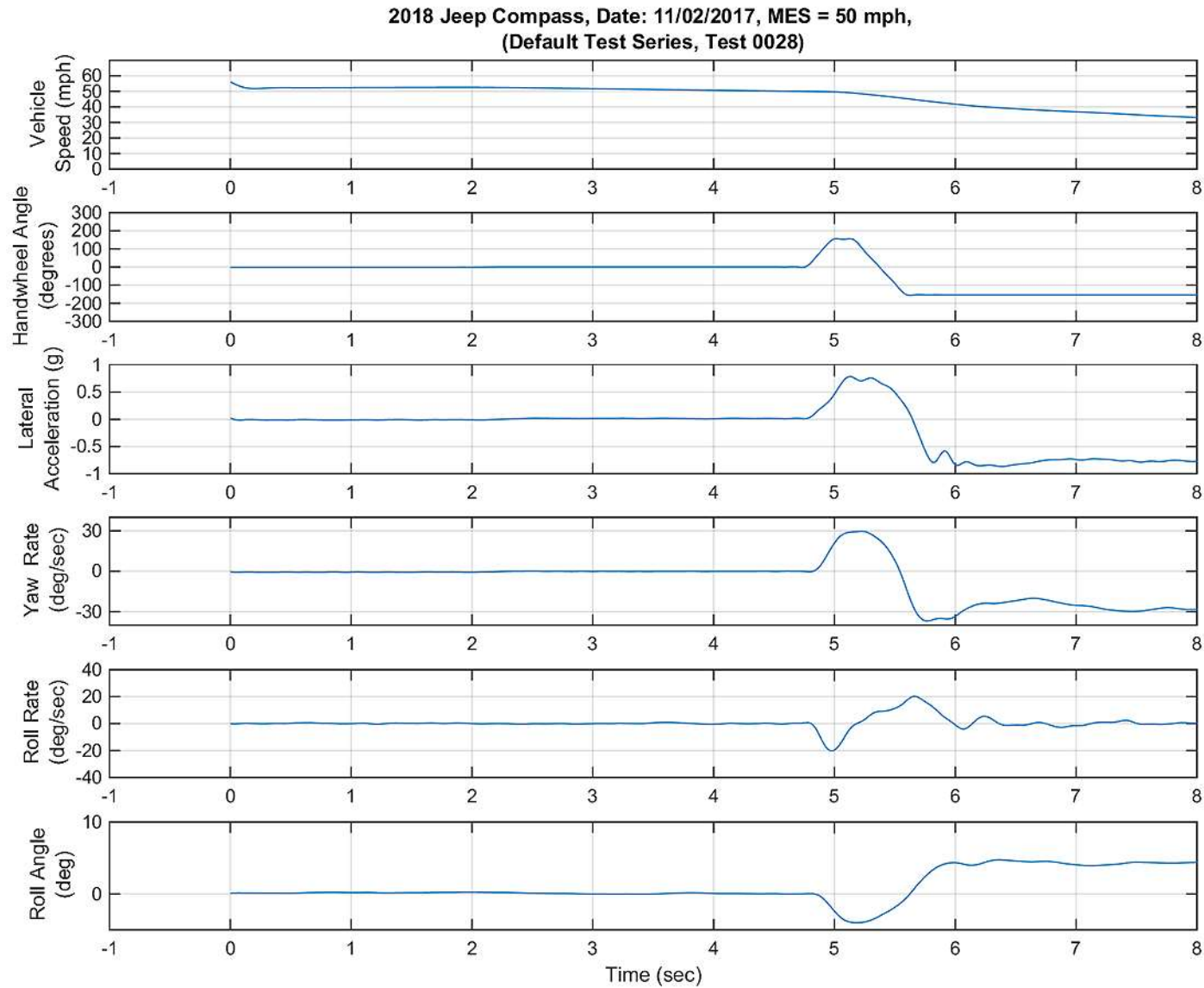

Figure D15. Yaw Rate, Roll Rate, and Lateral Acceleration Time History Plots for Supplemental 2 Test Series, R-L, 50 mph

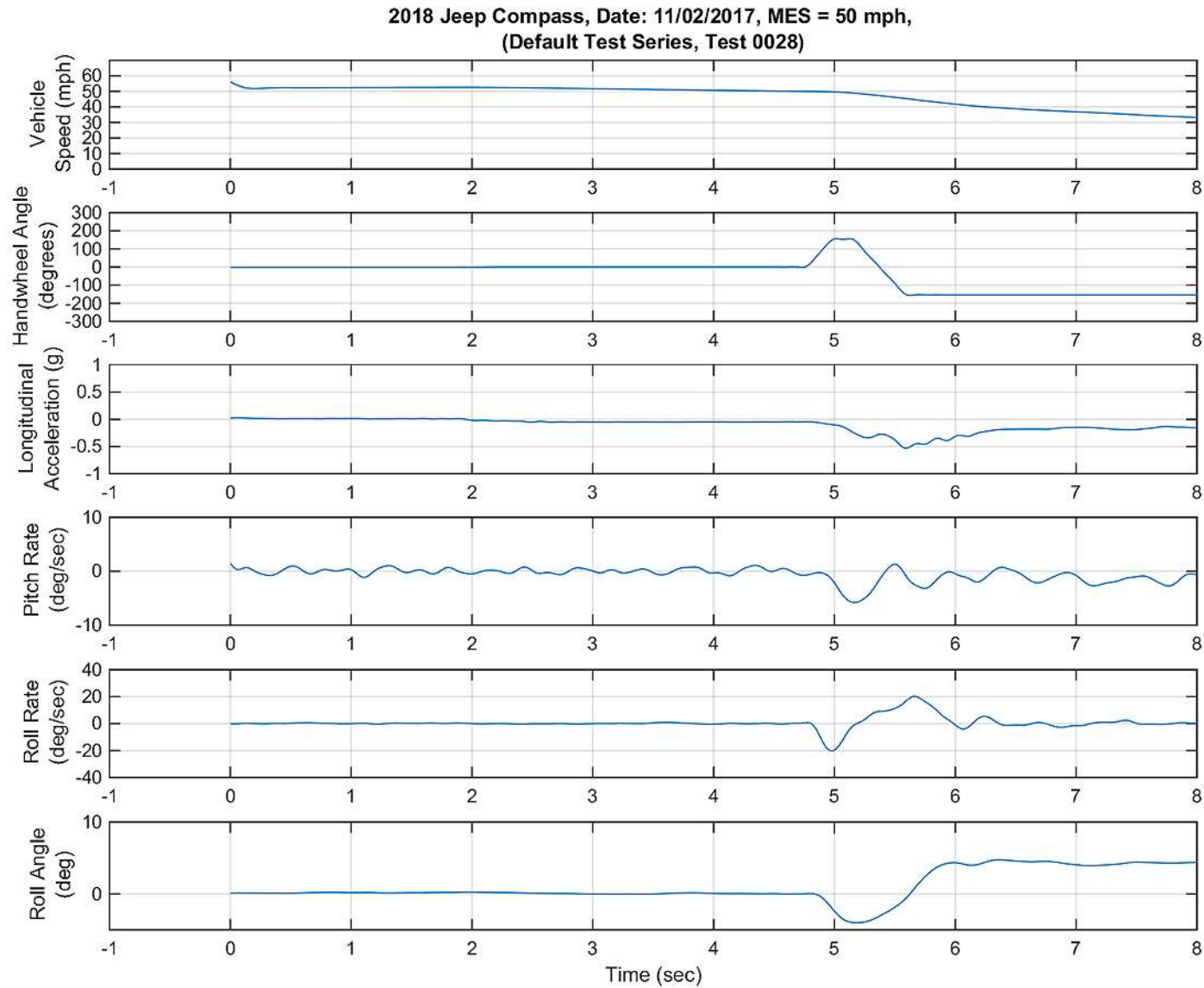

Figure D16. Pitch Rate and Longitudinal Acceleration Time History Plots for Supplemental 2 Test Series, R-L, 50 mph