

**NEW CAR ASSESSMENT PROGRAM (NCAP)  
DYNAMIC ROLLOVER RESISTANCE TEST**

Toyota Motor Corporation

2019 Toyota RAV4 FWD

TEST NUMBER: OCAS-DRI-RR-19-19

Final Report  
15 August 2019



Prepared by:

Dynamic Research, Inc  
355 Van Ness Ave. #200  
Torrance, CA 90501

Prepared for:

National Highway Traffic Safety Administration  
Office of Crash Avoidance Standards  
1200 New Jersey Avenue S.E.  
Washington, DC 20590

The United States Government assumes no liability for the contents of this report or use thereof. If trade or manufacturers' names or products are mentioned, it is only because they are considered essential to the object of the publication and should not be construed as an endorsement. The United States Government does not endorse products or manufacturers.

Dynamic Research, Inc. does not endorse or certify products of manufacturers. The manufacturer's name appears solely to identify the test article. Dynamic Research, Inc. assumes no liability for the report or use thereof. It is responsible for the facts and the accuracy of the data presented herein. This report does not constitute a standard, specification, or regulation.

Report Prepared by:

John Lenkeit, Program Manager

Date: 15 August 2019

1. Report No. <b>OCAS-DRI-RR-19-19</b>	2. Government Accession No.	3. Recipient's Catalog No.	
4. Title and Subtitle <b>NCAP Dynamic Rollover Resistance Maneuver (Fishhook) Test of a 2019 Toyota RAV4 FWD SUV</b>		5. Report Date <b>15 August 2019</b>	6. Performing Organization Code <b>DRI</b>
		8. Performing Organization Report No. <b>DRI- TM-18-87</b>	
7. Author(s) <b>John Lenkeit, Program Manager Peter Broen, Project Engineer</b>		10. Work Unit No. (TRAIS)	
9. Performing Organization Name and Address <b>Dynamic Research, Inc. 355 Van Ness Ave. #200 Torrance, CA 90501</b>		11. Contract or Grant No. <b>DTNH22-14-D-00332</b>	
		13. Type of Report and Period Covered <b>Final Report March 2019 to August 2019</b>	
12. Sponsoring Agency Name and Address  <b>National Highway Traffic Safety Administration Office of Crash Avoidance Standards 1200 New Jersey Avenue S.E. Washington, DC 20590</b>		14. Sponsoring Agency Code	
		15. Supplemental Notes	
16. Abstract  An NCAP Dynamic Rollover Maneuver (Fishhook) Test was conducted on a 2019 Toyota RAV4 FWD at Dynamic Research, Inc. on March 1, 2019. The vehicle did not experience two-wheel lift. The vehicle's steering angle at 0.3 g lateral acceleration at 50 mph was 27.5 degrees.			
17. Key Words <b>NCAP Rollover Resistance Ratings Fishhook Test</b>		18. Distribution Statement Copies of this report are available from: National Highway Traffic Safety Admin. Office of Crash Avoidance Standards 1200 New Jersey Ave., S.E. Washington, DC 20590	
19. Security Classif. (of this report) <b>Unclassified</b>	20. Security Classif. (of this page) <b>Unclassified</b>	21. Number of Pages <b>55</b>	22. Price

## TABLE OF CONTENTS

	Page
I. INTRODUCTION.....	1
II. VEHICLE PREPARATION .....	2
A. Test Vehicle .....	2
B. Tires .....	2
C. Vehicle Loading.....	2
D. Steering Controller .....	5
E. Real-Time Controller and Data Acquisition .....	5
F. Equipment Weight.....	6
G. Sensors.....	6
H. Other Vehicle Preparation .....	7
III. TEST PROCEDURES.....	10
A. Test Procedure Overview.....	10
B. Test Conditions .....	11
IV. RESULTS.....	14
APPENDIX A Photographs .....	A-1
APPENDIX B Test Run Log.....	B-1
APPENDIX C Slowly Increasing Steer Test Worksheet.....	C-1
APPENDIX D Time History Plots .....	D-1

## LIST OF FIGURES

	Page
1. Nominal Position of Video Cameras for Fishhook Tests .....	9
2. DRI-Minter Vehicle Dynamics Area .....	13

## LIST OF TABLES

	Page
1. Test Vehicle Data .....	3
2. Tire Information .....	4
3. Vehicle Loading .....	4
4. Weight of In-Cab Test equipment.....	6
5. Sensor Specifications .....	8
6. Surface Friction .....	11
7. Handwheel Angles .....	11
8. Weather Conditions.....	12

## Section I INTRODUCTION

Beginning with the 2006 fiscal year, the National Highway Traffic Safety Administration (NHTSA) has engaged Dynamic Research, Inc. (DRI) of Torrance, CA to conduct dynamic rollover testing and gather data from that testing as part of NHTSA's New Car Assessment Program (NCAP).

The purpose of the testing reported herein was to determine if a typical 2019 Toyota RAV4 FWD would experience tip-up, defined as simultaneous two-wheel lift of two inches or more at an entry speed of 50 mph or less in the Fishhook Procedure developed by NHTSA. This procedure may be found at [www.regulations.gov](http://www.regulations.gov), docket item NHTSA-2006-26555-0136.

The testing reported herein was accomplished under contract DTNH22-14-D-00332. The task order is entitled, "NCAP Dynamic Rollover Testing."

## Section II VEHICLE PREPARATION

### A. TEST VEHICLE

The test vehicle was new or in as-new condition, meaning the vehicle had been driven no more than 500 miles prior to the start of dynamic rollover testing. It was acquired through a commercial rental/leasing company. Details of the test vehicle are given in Table 1.

### B. TIRES

All tires used were new, and of the same make, model, size, and DOT specification of those installed on the vehicle when purchased new. Tire inflation pressures were in accordance with the recommendations indicated on each vehicle's identification placard. To further reduce the possibility of tire debanding, the tires were mounted to the rims without the use of tire mounting lubricant. Tire specifications are listed in Table 2.

### C. VEHICLE LOADING

The multi-passenger load, described in the Fishhook Procedure, was used for all tests. The load and positioning of the load in the vehicle are listed in Table 3.

In addition to water dummies, the loading included instrumentation, a steering machine, and outriggers. Test vehicle bumper assemblies were removed for outrigger installation. The reduction in vehicle weight due to the removal of the bumpers was offset by the additional weight of the outriggers and their mounting system. The outrigger system typically outweighs the bumper assemblies.



Table 1. Test Vehicle Data

<b>General Data</b>					
Model year, make, model	2019 Toyota RAV4 FWD				
VIN	JTMK1RFV7KD00xxxx				
Body style	SUV				
Number of doors	4				
Trim level	LE				
Seating positions	Front:	2 <sup>nd</sup> row	3 <sup>rd</sup> row	4 <sup>th</sup> row	5 <sup>th</sup> row
	2	3	0	0	0
Electronic stability control	Yes				
4-Wheel ABS (Yes/No)	Yes				
Power steering (Yes/No)	Yes				
Major optional equipment	Blind Spot Monitor with Rear Cross-Traffic Alert				
Odometer at start of testing	12 miles				
<b>Drivetrain</b>					
Engine cylinder arrangement	Inline 4				
Engine displacement	2.5 L				
Transmission type	Automatic				
Drive arrangement	FWD				
<b>Chassis</b>					
Track width	F: 63.5 in (1612.9 mm) , R: 64 in (1625.6 mm)				
Wheelbase	106 in (2692.4 mm)				
Curb weight	3365 lb (1526.3 kg)				
<b>Certification Data from Vehicle's Label</b>					
Vehicle manufactured by	Toyota Motor Corporation				
Date of manufacture	11/18				
GVWR	4608 lb (2090 kg)				
GAWR Front	2535 lb (1150 kg)				
GAWR Rear	2535 lb (1150 kg)				

Table 2. Tire Information

Tire Manufacturer	Firestone
Tire Model	Destination LE2
Tire Size	Front: 225/65R17 Rear: 225/65R17
Load rating	Front: 102 Rear: 102
Speed rating	Front: H Rear: H
Treadwear grade	Front: 520 Rear: 520
Traction grade	Front: A Rear: A
Temperature grade	Front: B Rear: B
Location of "Recommended Tire Pressure" label	Driver's door jamb
Recommended cold tire pressure	Front: 35 psi, (240 kPa) Rear: 35 psi, (240 kPa)
First 8 digits of DOT code	Front: EL F5 DHH Rear: EL F5 DHH

Table 3. Vehicle Loading

Water dummy and other loading	3 water dummies in second row
Water dummy weight	175 lb (79.4 kg)
Fuel level	Full
<b>Weight as Tested</b>	
Left front	1185 lb (537.5 kg)
Right front	1167 lb (529.3 kg)
Left rear	1040 lb (471.7 kg)
Right rear	998 lb (452.7 kg)

#### D. STEERING CONTROLLER

Precise controlled steering is accomplished using a steering machine designed and constructed by DRI. DRI has used its Automated Vehicle Controller (AVC) steering machine for many vehicle tests including FMVSS 126 tests. It can provide up to 65 ft-lb torque and rates over 1300 deg/sec. The integrated angle encoder has an unlimited range with a resolution of 0.045 degrees and an accuracy of  $\pm 0.045$  degrees. The steering motor is controlled by a MicroAutoBox II from dSPACE, which also acts as the data acquisition system.

#### E. REAL-TIME CONTROLLER AND DATA ACQUISITION

Data acquisition is achieved using a MicroAutoBox II from dSPACE, which also serves as the real-time system for the steering controller. Data from the Oxford IMU, including Longitudinal, Lateral, and Vertical Acceleration, Roll, Yaw, and Pitch Rate, Forward and Lateral Velocity, Roll and Pitch Angle, are sent over Ethernet to the Micro AutoBox. The Oxford IMUs are calibrated per the manufacturer's recommended schedule (Table 5). The MicroAutoBox II specifications are:

Model: D-Space Micro-Autobox II 1401/1513  
Base Board SN 549068  
I/O Board SN 588523

Two video cameras were used to record the Fishhook runs. They were positioned nominally as shown in Figure 1. The recorded videotapes were reviewed after the Fishhook runs to check for any two-wheel lift. If any two-wheel lift was observed, eight infrared distance-measuring sensors for measurement of wheel lift (two sensors at each wheel) were then mounted for use in subsequent confirmation Fishhook tests.

## F. EQUIPMENT WEIGHT

Table 4 lists the equipment and associated weights outlined in the NHTSA Laboratory Test Procedure for Dynamic Rollover and the equipment at DRI used for this specific test program. The equipment used at DRI for this test program differs slightly from the equipment that was previously used by NHTSA for rollover testing. Because DRI's equipment is lighter than NHTSA's equipment, DRI uses ballast to maintain a consistent weight and weight distribution in the vehicle.

Table 4. Weight of In-Cab Test Equipment

Equipment	Location	Equipment Weight (lb)	
		NHTSA*	DRI
Data Acquisition System	Front passenger seat	58	
Steering Machine	Handwheel	31	31
Steering Machine Electronics Box	Passenger row foot well behind the front passenger seat. If vehicle does not have a rear passenger row foot well, the Electronics Box should be placed in the front passenger seat foot well.	39	
MABX, and laptop	Front passenger seat		21
Motor control and power supply	Front passenger footwell		26
Ballast	Front passenger footwell		50
<b>Total</b>		<b>128</b>	<b>128</b>

\* Table A.1 from US DOT NHTSA - Laboratory Test Procedure for Dynamic Rollover - The Fishhook Maneuver Test Procedure - New Car Assessment Program (NCAP) - March 2013

## G. SENSORS

A list of the sensors is given in Table 5.

## H. OTHER VEHICLE PREPARATION

In addition to installation and preparation discussed above, the test vehicle was prepared as follows:

- Front and rear bumpers were removed
- Outrigger mounts were installed in the bumper locations and titanium outriggers were fastened to these mounts
- Airbags were removed or otherwise disabled

Photographs of the vehicle tested are given in Appendix A.

Table 5. Sensors

Measured Variable	Sensor	Range	Resolution	Accuracy	Specifics	Serial Number	Calibration
Vehicle Tire Pressure	Tire Pressure Gauge	0-100 psi 0-690 kPa	0.01 psi 6.89 kPa	< 1% error between 20 and 100 psi	Omega DPG8001	17042707002	By: DRI Date: 6/21/2018 Due: 6/21/2019
Vehicle Total, Wheel, and Axle Load	Platform Scales (Minter)	1200 lb/platform 5338 N/platform	1 lb 4.4 N	0.5% of applied load	Intercomp SWI	1110M206352	By: DRI Date: 1/3/2019 Due: 1/3/2020
	Platform Scales (Torrance)	1500 lb/platform 6672 N/platform	1 lb 4.4 N	0.5% of applied load	Intercomp SW I	24032361	By: DRI Date: 12/11/2018 Due: 12/11/2019
Handwheel Angle	Steering Angle Encoder (Automated Steering Controller)	±800 deg	0.045 deg	±0.045 deg	DRI Automatic Vehicle Controller using D-Space Micro- Autobox II	NA	Verified by DRI at installation <sup>1</sup>
Longitudinal, Lateral, and Vertical Acceleration Roll, Yaw, and Pitch Rate, Forward and Lateral Velocity, Roll and Pitch Angle	Multi-Axis Inertial Sensing System	Accels ± 5 g, Angular Rate ±300 deg/s, Angle >45 deg, Velocity >200 km/h	Accels .001 g, Angular Rate 0.01 deg/s, Angle 0.05 deg, Velocity 0.1 km/h	Accels .001g, Angular Rate 0.01 deg/s, Angle 0.05 deg, Velocity 0.1 km/h	Oxford xNav 550	015360	By: Oxford Technical Solutions Date: 6/21/2017 Due: 6/21/2019

1 . The steering encoder is checked prior to beginning tests to verify that there are no faults. The steering controller is installed in the vehicle and the steering wheel is turned through two complete revolutions while recording data. The data are then reviewed for any dropouts or other nonlinearities that would indicate dust intrusion or faulty sectors.

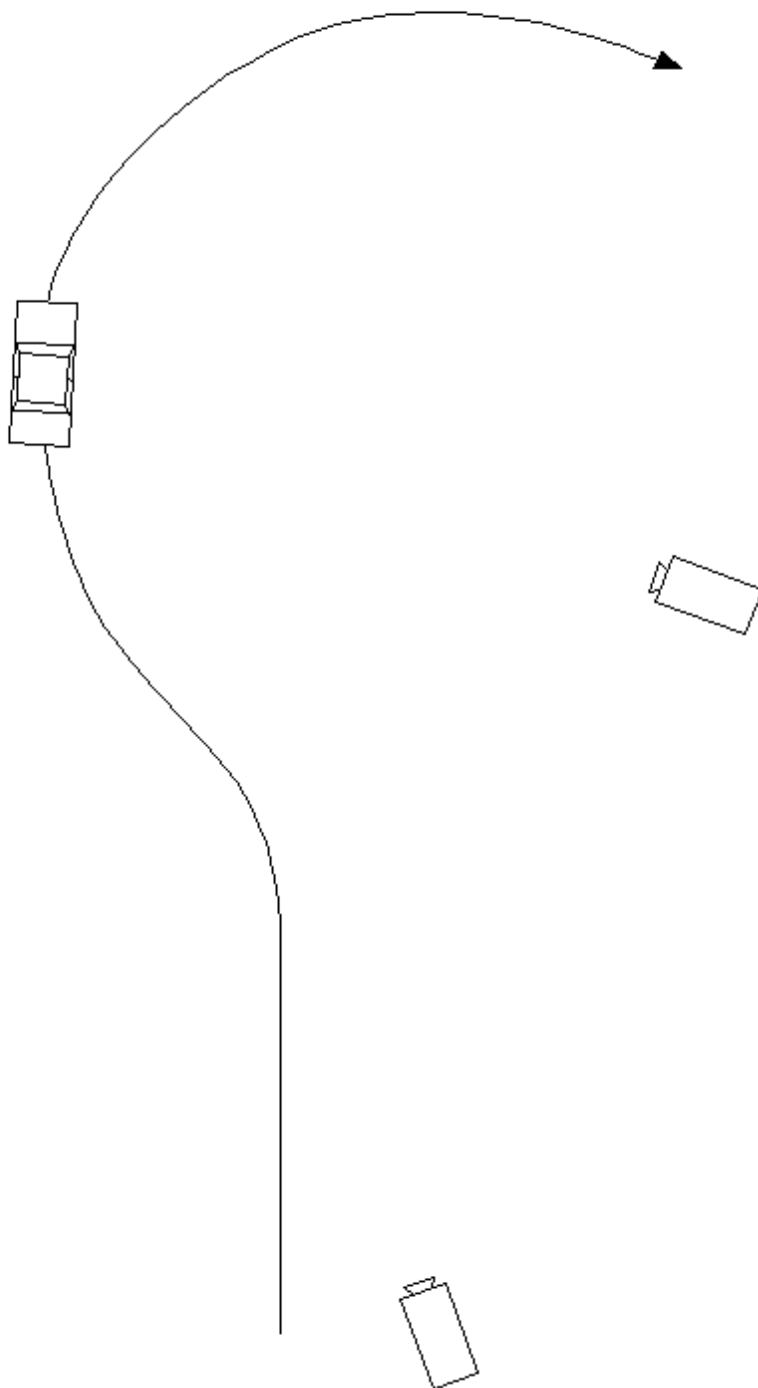

Figure 1. Nominal Position of Video Cameras for Fishhook Tests

### Section III TEST PROCEDURES

This section includes a general overview of the test procedures and details of the particular test.

#### A. TEST PROCEDURE OVERVIEW

This test was conducted in accordance with NHTSA's NCAP Rollover Resistance Test Procedure (Fishhook) as described in the Federal Register (68 FR 59250). Detailed descriptions of the test procedure, pass/fail criteria, and data acquisition specifications may be found at docket NHTSA-2001-9663.

There are two major components of the test procedure, the Slowly Increasing Steer (SIS) pre-test and the Fishhook test.

The Slowly Increasing Steer (SIS) maneuver was used to characterize the steady state lateral dynamics of each vehicle, and is based on the "Constant Speed, Variable Steer" test defined in SAE J266. The maneuver is used to determine the handwheel angle that produces a lateral acceleration of 0.3 g at 50 mph. This handwheel angle is then used to determine the magnitude of steering to be used for the NHTSA Fishhook maneuver.

SIS tests were performed at a constant speed of 50 mph. Handwheel angle was input at a rate of 13.5 deg/sec, from 0 to an angle that provided at least 0.55 g. Three tests were conducted in each direction, and the data for the six runs were averaged to obtain the handwheel angle that produced 0.3 g at 50 mph.

The Fishhook test is a programmed steering maneuver that is implemented via the steering controller. The vehicle was initially steered in one direction and then the steering was reversed. The timing, magnitude, and rate of the steering were prescribed by the Fishhook Procedure.

To begin the maneuver, the vehicle was driven in a straight line at a speed slightly greater than the desired entrance speed. The driver then released the throttle. When the vehicle was at the target speed, the steering controller automatically initiated the steering maneuver. Following completion of the steering reversal, the handwheel position was maintained for three seconds and then returned to zero angle in 1 second.



The tests were conducted in both left-right and right-left directions. The “Default” test series used a handwheel angle equal to 6.5 times the handwheel angle that produced 0.3 g at 50 mph in the SIS tests, and initial vehicle speeds beginning at 35 mph and concluding up to 50 mph (if no two-wheel lift occurs). Supplemental tests were also done, as specified in the Fishhook Procedure.

## B. TEST CONDITIONS

### 1. Test Surface

The tests were conducted on the Vehicle Dynamics Area at DRI’s Minter Field facility, located near Bakersfield, California, on 3/1/2019. The VDA has a smooth, flat (slope less than 0.5% throughout) asphaltic concrete surface. Its dimensions are as shown in Figure 2. It was built in the spring of 2005.

VDA surface friction measurements were accomplished using the DRI Mobile Tire Tester. Three runs were done, one at each of three previously determined locations. Each run provided for a minimum of 3 seconds of tire friction at constant normal load, slip angle, and speed in a free rolling condition. The test was accomplished using an ASTM E1136 tire with an inflation pressure of 35 ( $\pm 0.5$ ) psi at a test speed of 40 ( $\pm 0.5$ ) mph. The net slip angle of the test tire for each test run was 7.5 deg. The test tire was no older than 6 months from the date of manufacture. The surface friction measurement results are shown in Table 6.

Table 6. Surface Friction

Date of surface friction measurements	3/5/2019
Average normalized lateral force	0.821

### 2. Fishhook Handwheel Angles

The 0.3 g handwheel angle obtained from the SIS tests and the handwheel angles used in the Fishhook tests are shown in Table 7.

Table 7. Handwheel Angles

0.3 g handwheel angle (from SIS tests at 50 mph)	27.5°
5.5 scalar handwheel angle for Fishhook Test	151°
6.5 scalar handwheel angle for Fishhook Test	179°

### 3. Weather Conditions

The weather conditions, recorded at the end of testing, are shown in Table 8.

Table 8. Weather Conditions

Ambient temperature	15° F ( -9.4° C)
Wind Speed	4 mph (1.8 m/s)
Wind Direction	34

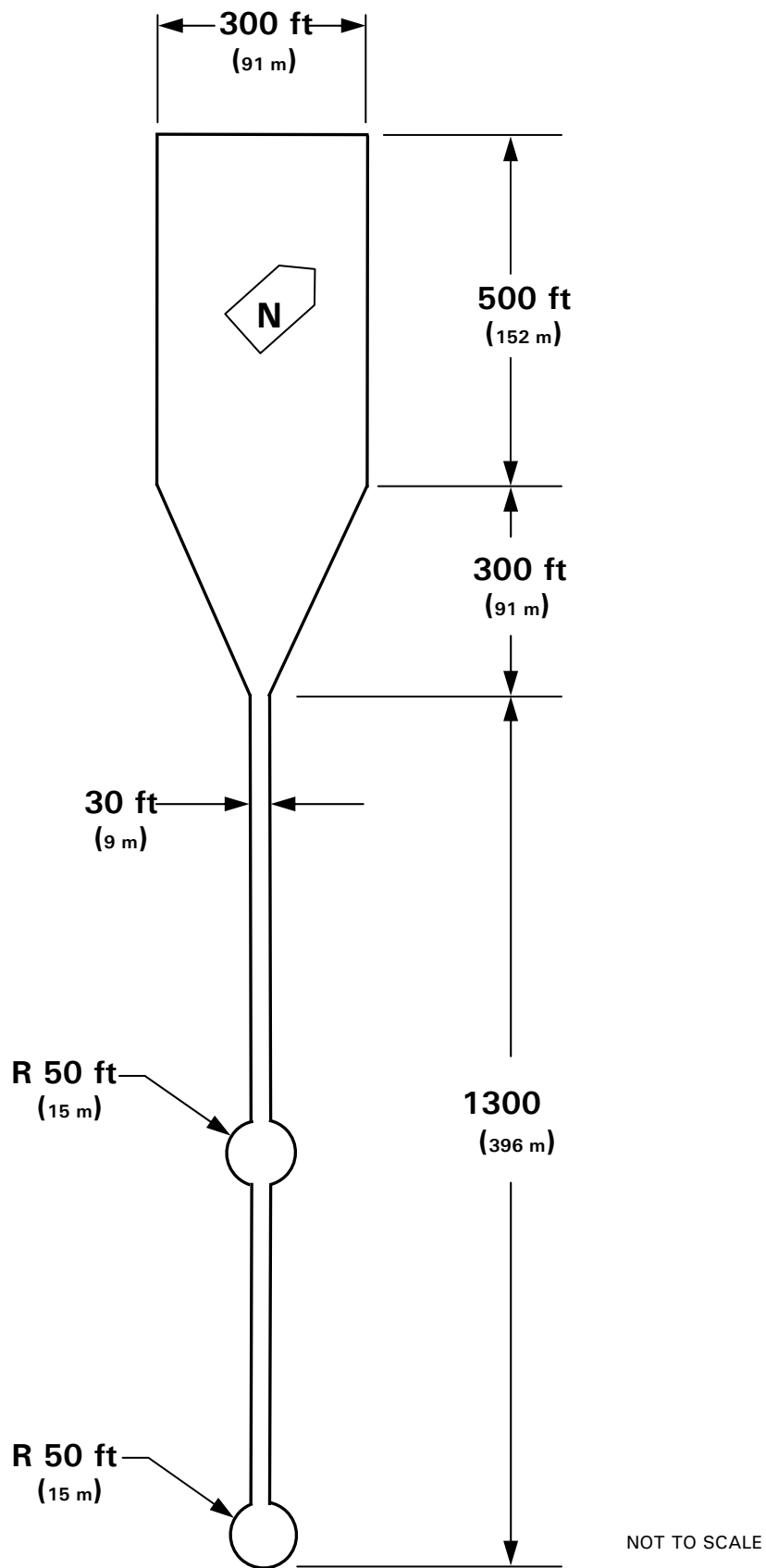

Figure 2. DRI-Minter Vehicle Dynamics Area

## Section IV RESULTS

The test run log is given in Appendix B. The Slowly Increasing Steer Test Worksheet is given in Appendix C. Appendix D contains time history plots for the 50 mph runs and any runs which resulted in two-wheel lift. For the 2019 Toyota RAV4 FWD, there was no two-wheel lift at any test condition.

APPENDIX A

Photographs

## LIST OF FIGURES

	Page
A1. Window Sticker.....	A-3
A2. Front View, Test Vehicle as Delivered .....	A-4
A3. Rear View, Test Vehicle as Delivered .....	A-5
A4. Front View, Test Vehicle in Test Condition .....	A-6
A5. Rear View, Test Vehicle in Test Condition .....	A-7
A6. Certification Label.....	A-8
A7. Tire Placard .....	A-9
A8. Instrumentation in Test Vehicle .....	A-10
A9. Steering Controller and Computer .....	A-11
A10. Ballast Condition.....	A-12



**TOYOTA**  
Let's Go Places

DESC: **RAV4 LE FWD SUV**  
VIN: **JTMK1RFV7KD00**  
YR/MDL: 2019/4430A  
CLR: SUPER WHITE/FB20 (0040/20)  
FINAL ASSEMBLY POINT: TOYOTA, AICHI, JAPAN

**STANDARD EQUIPMENT**

**MECHANICAL & PERFORMANCE**

- 2.5L DOHC 4-cylinder Engine w/Dual VVT-I
- 203 hp @ 6600 rpm / 184 lb-ft @ 5000 rpm
- Direct Shift 8-spd Auto Transmission
- Front Wheel Drive (FWD)
- Eco, Sport and Normal Modes

**SAFETY & CONVENIENCE**

- Toyota Safety Sense 2.0: Pre-Collision Sys w/Pedestrian Detection, Full-Speed Range Dynamic Radar Cruise Control, Lane Departure Alert w/Steering Assist, Lane Tracing Assist, Automatic High Beams, Road Sign Assist
- Star Safety System: VSC, TRAC, ABS, Elect Brake-Force Distribution, Brake Assist(BA) & Smart Stop Technology (SST)
- Eight Airbags
- Integrated Back-Up Camera
- LATCH-Lower Anchor & Tether for Children

**EXTERIOR**

- 17-in. Steel Wheels with Covers
- LED Headlights/Daytime Running Lights
- Power Outside Mirrors
- Low Profile Roof Rails
- Privacy Glass

**INTERIOR**

- Entune 3.0 Audio
- 7.0" Touch Screen, 8 Speakers, HandsFree Bluetooth Phone/Music, USB Media Port, Two 12V Power Outlets
- Siri Eyes Free, Apple CarPlay Compatible
- 4.2" Color Multi-Information Display
- Remote Keyless Entry
- Fabric Seats
- Electronic Parking Brake
- \*\*\*Full Tank of Gas\*\*\*

**MANUFACTURER'S SUGGESTED RETAIL PRICE \$25,500.00**

**OPTIONAL EQUIPMENT**

FE	50 State Emissions	
BD	Blind Spot Monitor (BSM) with Rear Cross-Traffic Alert (RCTA) - Includes Color-Keyed Heated Power Outside Mirrors with Turn Signal and Blind Spot Warning Indicators	590.00
TC	Rear Cargo Area Cover	90.00
ZT	All Weather Floor Liners and Cargo Tray	269.00
DS	Door Edge Guard	140.00
MF	Mudguard	129.00

**GOVERNMENT 5-STAR SAFETY RATINGS**

This vehicle has not been rated by the government for overall vehicle score, frontal crash, side crash or rollover risk.

Star ratings range from 1 to 5 stars (★★★★★) with 5 being the highest.  
Source: National Highway Traffic Safety Administration (NHTSA)  
www.safercar.gov or 1-888-327-4236

**EPA DOT Fuel Economy and Environment** Gasoline Vehicle

**Fuel Economy**

**30** MPG  
combined city/hwy

26 35  
city highway

3.3 gallons per 100 miles

**You save \$500**  
in fuel costs over 5 years compared to the average new vehicle.

**Annual fuel cost \$1,300**

**Fuel Economy & Greenhouse Gas Rating (tailpipe only)** 7

**Smog Rating (tailpipe only)** 6

[fuelconomy.gov](http://fuelconomy.gov)  
Calculate personalized estimates and compare vehicles

**DELIVERY PROCESSING AND HANDLING FEE** 1,095.00

**TOTAL \$27,813.00**

The New Vehicle Limited Warranty provides 3-year/35,000-mile basic coverage, 5-year/60,000-mile powertrain coverage, plus 5-year/unlimited-mile corrosion perforation coverage. See Warranty and Maintenance Guide for details. An extended service contract may be available for the vehicle. Manufacturer's suggested retail price includes manufacturer's recommended pre-delivery service, gasoline, license and title fees, applicable federal, state and local taxes and dealer and distributor installed options and accessories are not included in the manufacturer's suggested retail price.

ToyotaCare, which covers normal factory scheduled maintenance for two years or 25,000 miles, whichever occurs first, is included as part of the base price of the vehicle for qualifying buyers. See participating dealer for eligibility and coverage details.

Figure A1. Window Sticker



Figure A2. Front View, Test Vehicle as Delivered





Figure A3. Rear View, Test Vehicle as Delivered



Figure A4. Front View, Test Vehicle in Test Condition



Figure A5. Rear View, Test Vehicle in Test Condition

MFD. BY: TOYOTA MOTOR CORPORATION 11/18  
 GVWR: 2090KG (4610LB)  
 GAWR: FRT. 1150KG (2535LB) WITH 225/65R17 TIRES.  
                   17X7J RIMS.  
                   RR. 1150KG (2535LB) WITH 225/65R17 TIRES.  
                   17X7J RIMS.  
 THIS VEHICLE CONFORMS TO ALL APPLICABLE FEDERAL MOTOR  
 VEHICLE SAFETY AND THEFT PREVENTION STANDARDS IN EFFECT ON  
 THE DATE OF MANUFACTURE SHOWN ABOVE.  
 JTMK1RFV7KD00 MPV



C/TR: 040/FB20 AXAA52L - ANZXBA 083  
 A/TM: -01A/UB80E MADE IN JAPAN E

Figure A6. Certification Label

**TIRE AND LOADING INFORMATION**      **RENSEIGNEMENTS SUR LES PNEUS ET LE CHARGEMENT**

**SEATING CAPACITY: TOTAL 5**  
 FRONT 2: REAR 3  
 The combined weight of occupants and cargo should never exceed 410 kg or 900 lbs.

**NOMBRE DE PLACES: TOTAL 5**  
 AVANT 2: ARRIÈRE 3  
 Le poids total des occupants et du chargement ne doit jamais dépasser 410 kg ou 900 lb.

TIRE	SIZE	COLD TIRE PRESSURE	PNEU	DIMENSIONS	PRESSION DES PNEUS À FROID
FRONT	225/65R17	240kPa, 35PSI	AVANT	225/65R17	240kPa, 35PSI
REAR	225/65R17	240kPa, 35PSI	ARRIÈRE	225/65R17	240kPa, 35PSI
SPARE	T165/80R17	420kPa, 60PSI	DE SECOURS	T165/80R17	420kPa, 60PSI

**SEE OWNER'S MANUAL FOR ADDITIONAL INFORMATION.**

**VOIR LE MANUEL DE L'USAGER POUR PLUS DE RENSEIGNEMENTS.**

**QE 42A10**

Figure A7. Tire Placard

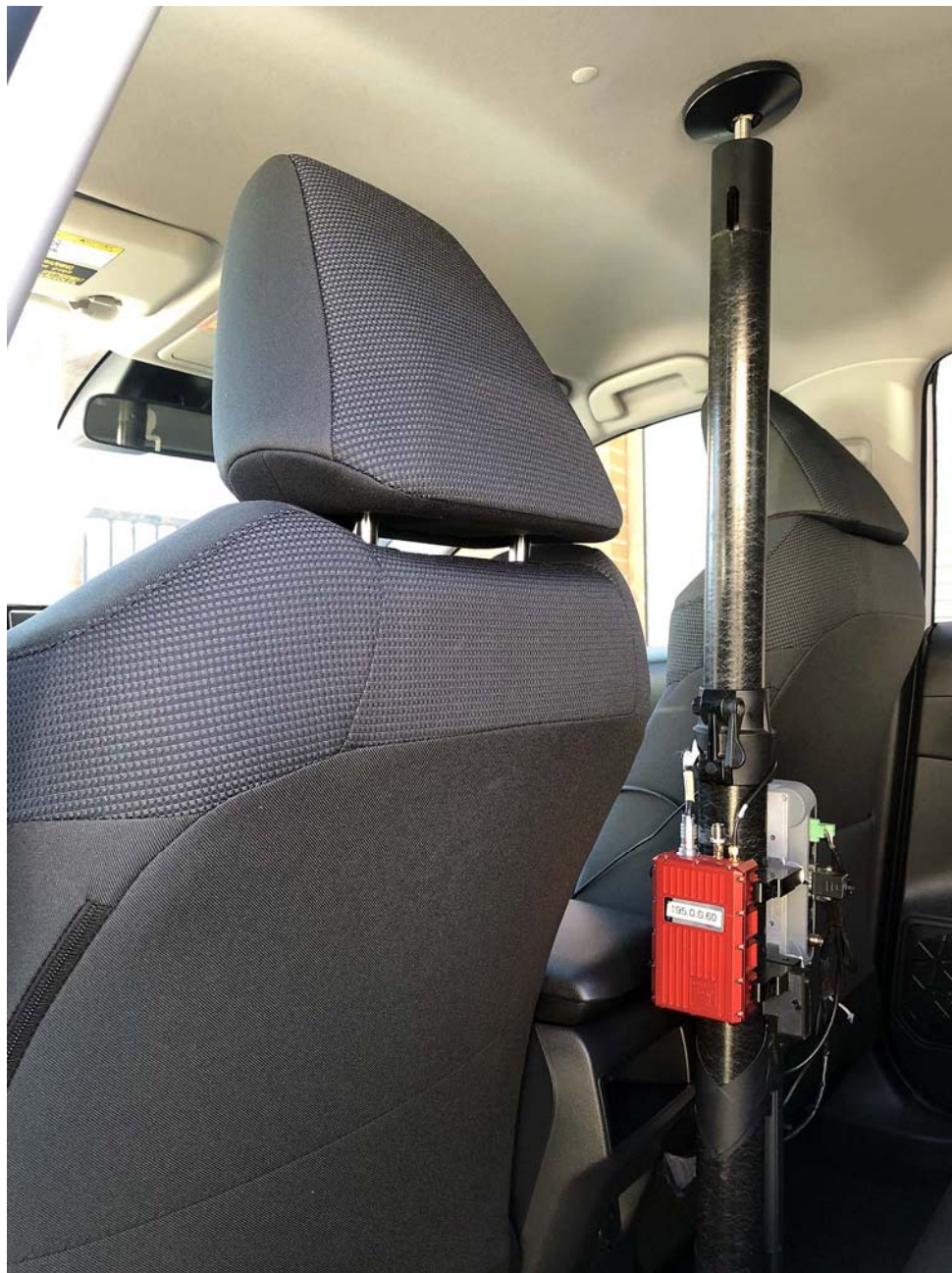

Figure A8. Instrumentation in Test Vehicle



Figure A9. Steering Controller and Computer



Figure A10. Ballast Condition



APPENDIX B

Test Run Log

Vehicle: **2019 Toyota RAV4 FWD**Driver: **Jonathan Robel**Test Date: **3/1/2019**

Run Number	Test Type	Speed (mph)	Handwheel Angle (deg)	Dir. of First Steer	2 Wheel Lift	Notes
1	Tire Warm-Up	35	60	Right		
2	"	"	"	"		
3	"	"	"	"		
4	"	"	"	"		
5	2x SWA last cycle	"	"	"		
6	Static	0	0			
7	Steady State	50	0			
8	<b>Slowly Increasing Steer</b>	50	50	Left		
9	"	"	"	Left		
10	"	"	"	Left		
11	"	"	"	Right		
12	"	"	"	Right		
13	"	"	"	Right		
14	<b>Fishhook 6.5 Scalar</b>	35	179	Left	No	
15	"	40	"	"	"	
16	"	45	"	"	"	
17	"	47.5	"	"	"	
18	"	50	"	"	"	
19	<b>Fishhook 5.5 Scalar</b>	45	151	Left	No	
20	"	47.5			"	
21	"	50			"	

Vehicle: **2019 Toyota RAV4 FWD**Driver: **Jonathan Robel**Test Date: **3/1/2019**

Run Number	Test Type	Speed (mph)	Handwheel Angle (deg)	Dir. of First Steer	2 Wheel Lift	Notes
22	<b>Fishhook 6.5 Scalar</b>	35	179	Right	No	
23	"	40	"	"	"	
24	"	45	"	"	"	
25	"	47.5	"	"	"	
26	"	50	"	"	"	
27	<b>Fishhook 5.5 Scalar</b>	45	151	Right	No	
28	"	47.5	"	"	"	
29	"	50	"	"	"	

APPENDIX C

Slowly Increasing Steer Test Worksheet

## NCAP, 2019 Toyota RAV4 FWD , Multi-Passenger Load, Test Date: 3/1/2019

SIS\_out\_v2

Run	Dir of Steer	Start Speed (mph)	End Speed (mph)	Speed Red. (%)	Index of ay @ 0.3g	HW Angle (deg) at 0.3g	ay (g) @ 0.3g index	6.5x HW Angle (deg)	Ramp Time (sec) at 6.5x	5.5x HW Angle (deg)	Ramp Time (sec) at 5.5x	R2	Zero Begin Index	Zero End Index
8	L	49.8	-0.1	100.2	1217	-27.7	-0.295	-180.3	-0.2505	-152.6	-0.2119	0.9953	600	800
9	L	49.8	1.1	97.7	1212	-27.4	-0.303	-178.1	-0.2474	-150.7	-0.2094	0.9980	600	800
10	L	50.5	5.7	88.7	1212	-27.4	-0.293	-178.0	-0.2473	-150.6	-0.2092	0.9954	600	800
11	R	50.2	0.4	99.3	1212	27.5	0.292	178.5	0.2479	151.0	0.2098	0.9921	601	800
12	R	49.8	0.1	99.7	1210	27.3	0.298	177.6	0.2467	150.3	0.2087	0.9952	600	800
13	R	50.9	0.0	99.9	1217	27.8	0.295	180.7	0.2509	152.9	0.2123	0.9975	600	800

Mean: 27.5 0.296 179 0.248 151 0.21

## Steering Controller Input Values

## Scalar 6.5 values:

Initial HW angle: 179 deg  
 Initial time: 0.248 s  
 Reversal HW angle: -179 deg  
 Reversal time: 0.497 s

## Scalar 5.5 values:

Initial HW angle: 151 deg  
 Initial time: 0.21 s  
 Reversal HW angle: -151 deg  
 Reversal time: 0.42 s

## APPENDIX D

### Time History Plots

## LIST OF FIGURES

	Page
D1. Vehicle Speed, Handwheel Angle, and Roll Angle Time History Plots for Default Test Series, L-R, 50 mph .....	D-3
D2. Steering Machine Operation Time History Plots for Default Test Series, L-R, 50 mph.....	D-4
D3. Yaw Rate, Roll Rate, and Lateral Acceleration Time History Plots for Default Test Series, L-R, 50 mph .....	D-5
D4. Pitch Rate and Longitudinal Acceleration Time History Plots for Default Test Series, L-R, 50 mph .....	D-6
D5. Vehicle Speed, Handwheel Angle, and Roll Angle Time History Plots for Default Test Series, R-L, 50 mph .....	D-7
D6. Steering Machine Operation Time History Plots for Default Test Series, R-L, 50 mph .....	D-8
D7. Yaw Rate, Roll Rate, and Lateral Acceleration Time History Plots for Default Test Series, R-L, 50 mph .....	D-9
D8. Pitch Rate and Longitudinal Acceleration Time History Plots for Default Test Series, R-L, 50 mph .....	D-10
D9. Vehicle Speed, Handwheel Angle, and Roll Angle Time History Plots for Supplemental 2 Test Series, L-R, 50 mph.....	D-11
D10. Steering Machine Operation Time History Plots for Supplemental 2 Test Series, L-R, 50 mph .....	D-12
D11. Yaw Rate, Roll Rate, and Lateral Acceleration Time History Plots for Supplemental 2 Test Series, L-R, 50 mph .....	D-13
D12. Pitch Rate and Longitudinal Acceleration Time History Plots for Supplemental 2 Test Series, L-R, 50 mph .....	D-14
D13. Vehicle Speed, Handwheel Angle, and Roll Angle Time History Plots for Supplemental 2 Test Series, R-L, 50 mph.....	D-15
D14. Steering Machine Operation Time History Plots for Supplemental 2 Test Series, R-L, 50 mph .....	D-16
D15. Yaw Rate, Roll Rate, and Lateral Acceleration Time History Plots for Supplemental 2 Test Series, R-L, 50 mph .....	D-17
D16. Pitch Rate and Longitudinal Acceleration Time History Plots for Supplemental 2 Test Series, R-L, 50 mph .....	D-18

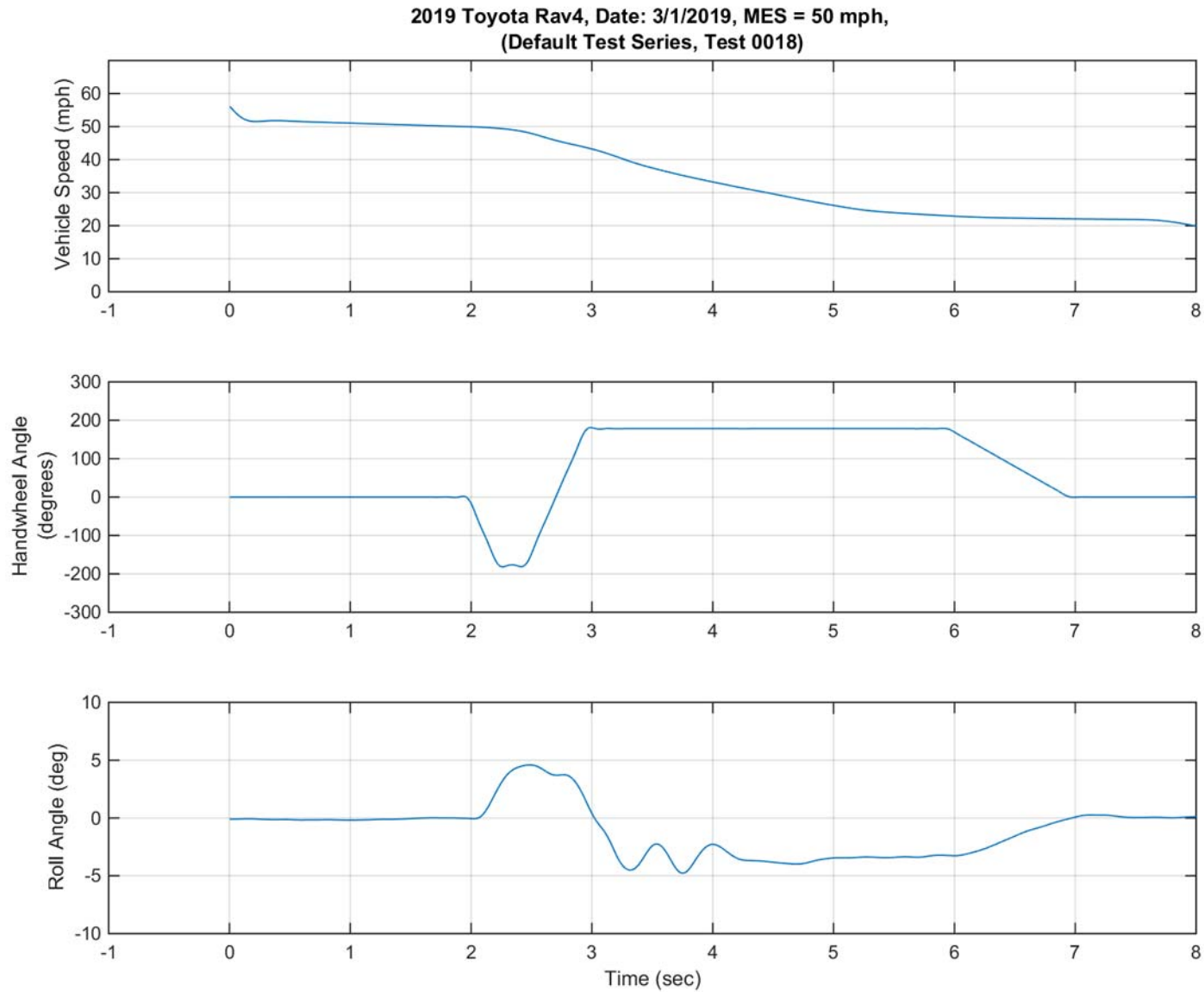

Figure D1. Vehicle Speed, Handwheel Angle, and Roll Angle Time History Plots for Default Test Series, L-R, 50 mph



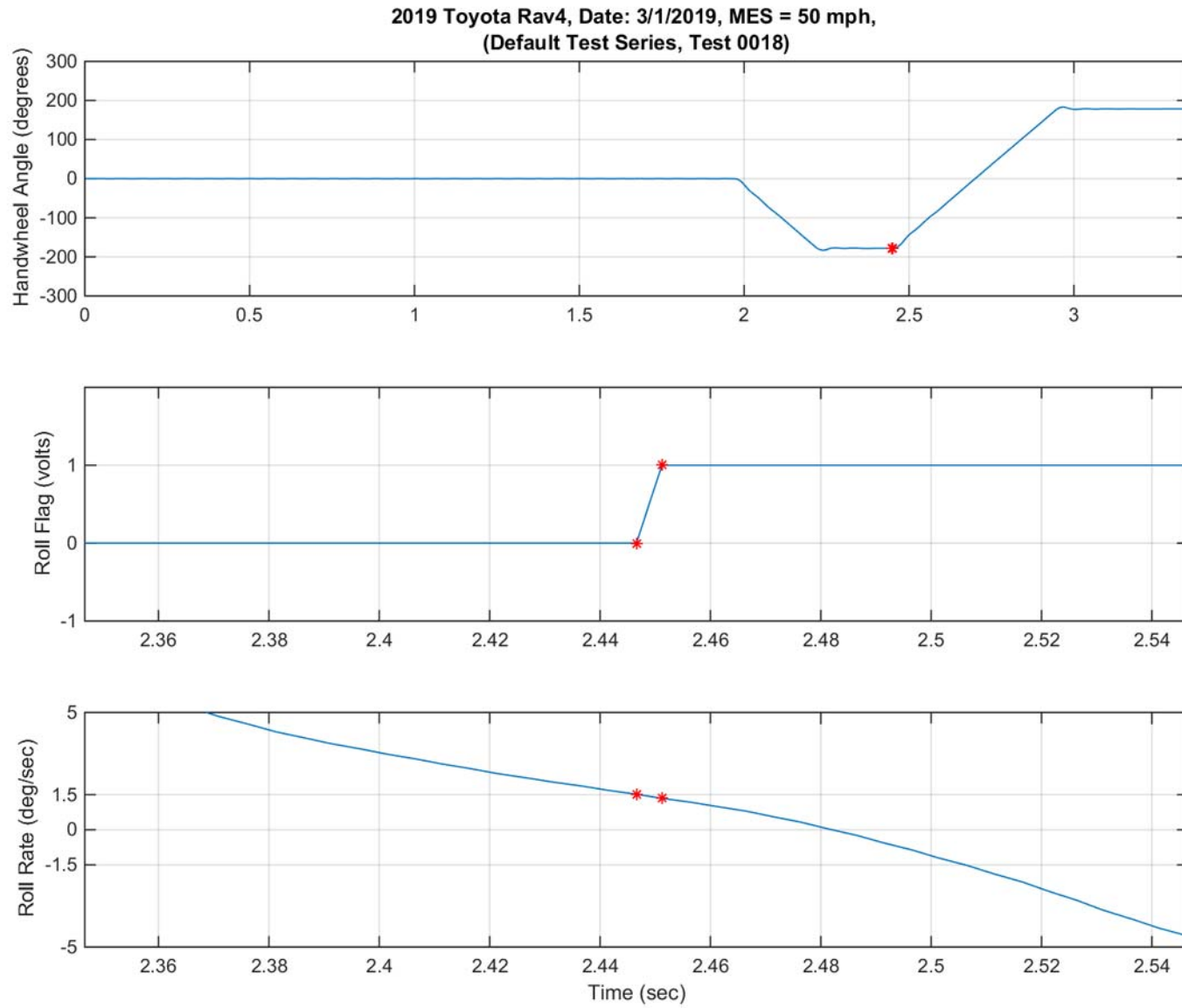

Figure D2. Steering Machine Operation Time History Plots for Default Test Series, L-R, 50 mph

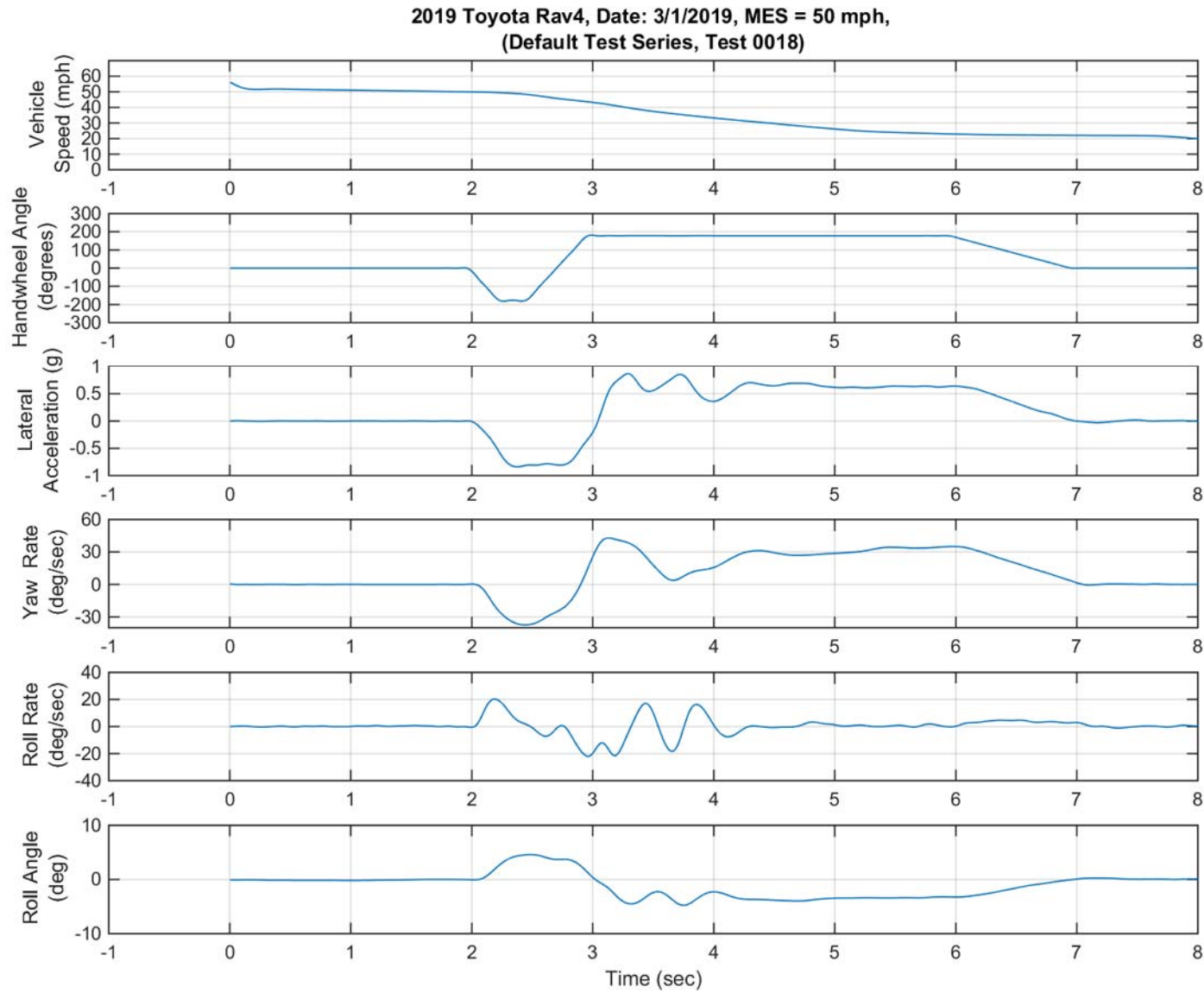

Figure D3. Yaw Rate, Roll Rate, and Lateral Acceleration Time History Plots For Default Test Series, L-R, 50 mph

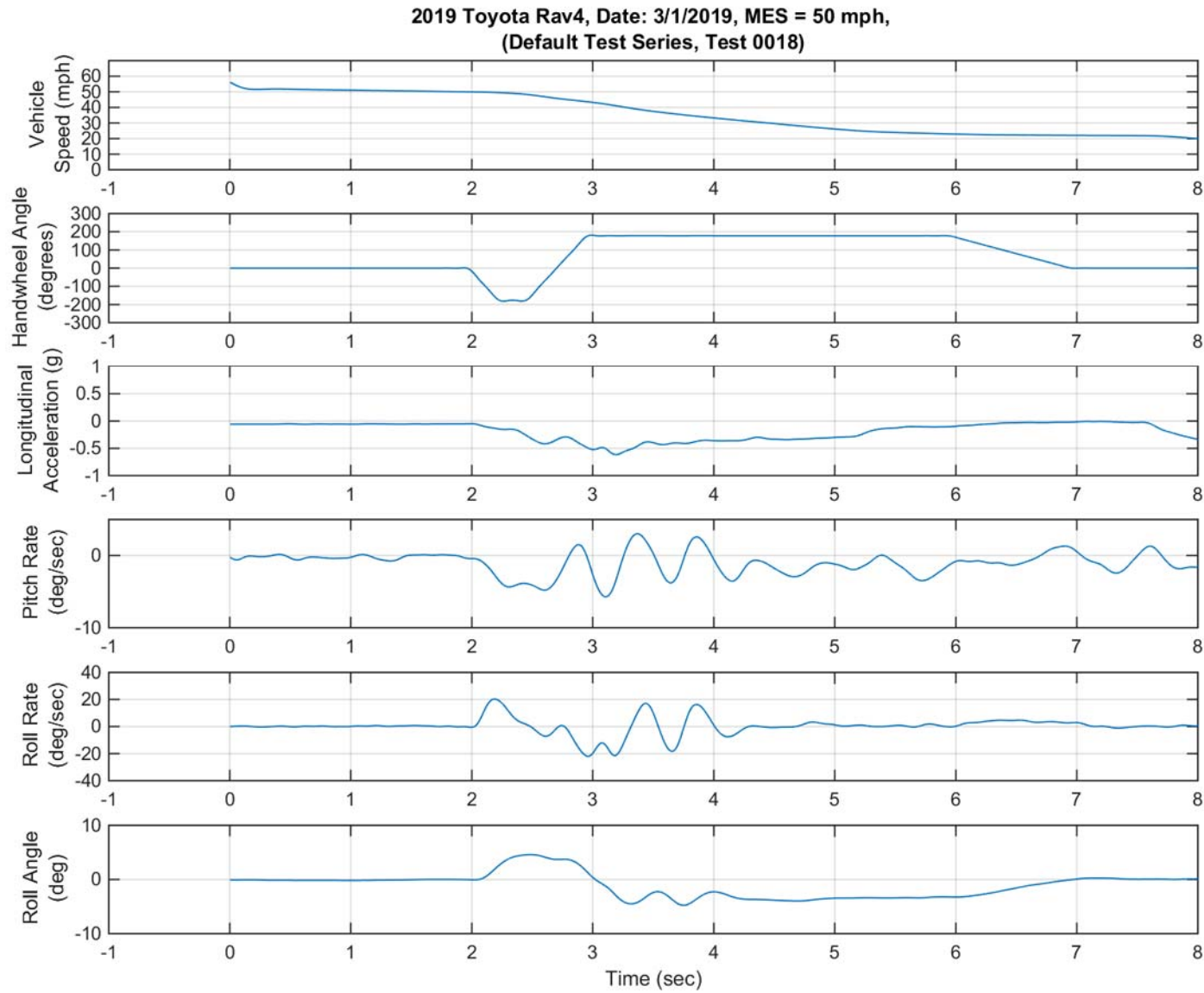

Figure D4. Pitch Rate and Longitudinal Acceleration Time History Plots for Default Test Series, L-R, 50 mph

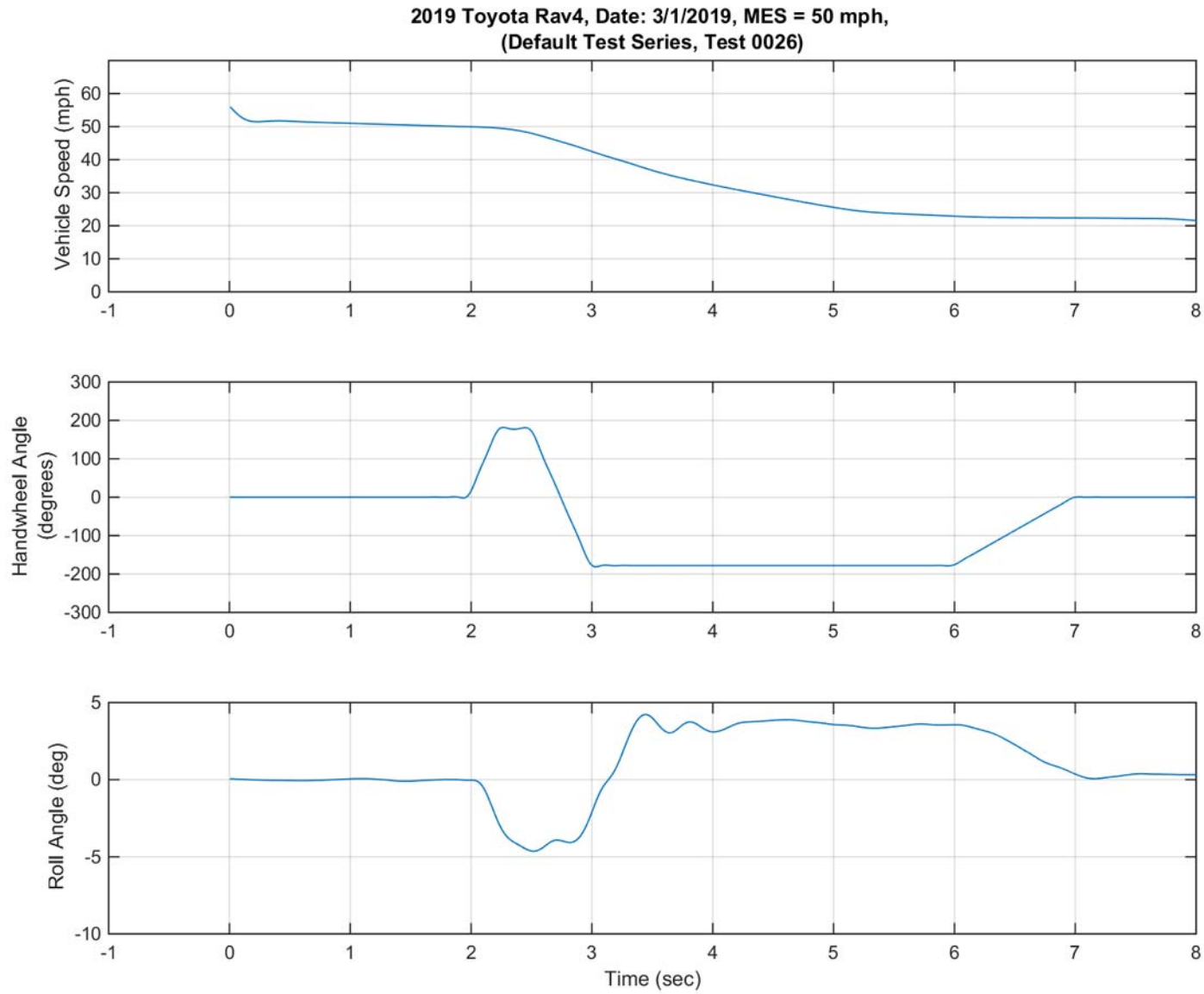

Figure D5. Vehicle Speed, Handwheel Angle, and Roll Angle Time History Plots for Default Test Series, R-L, 50 mph

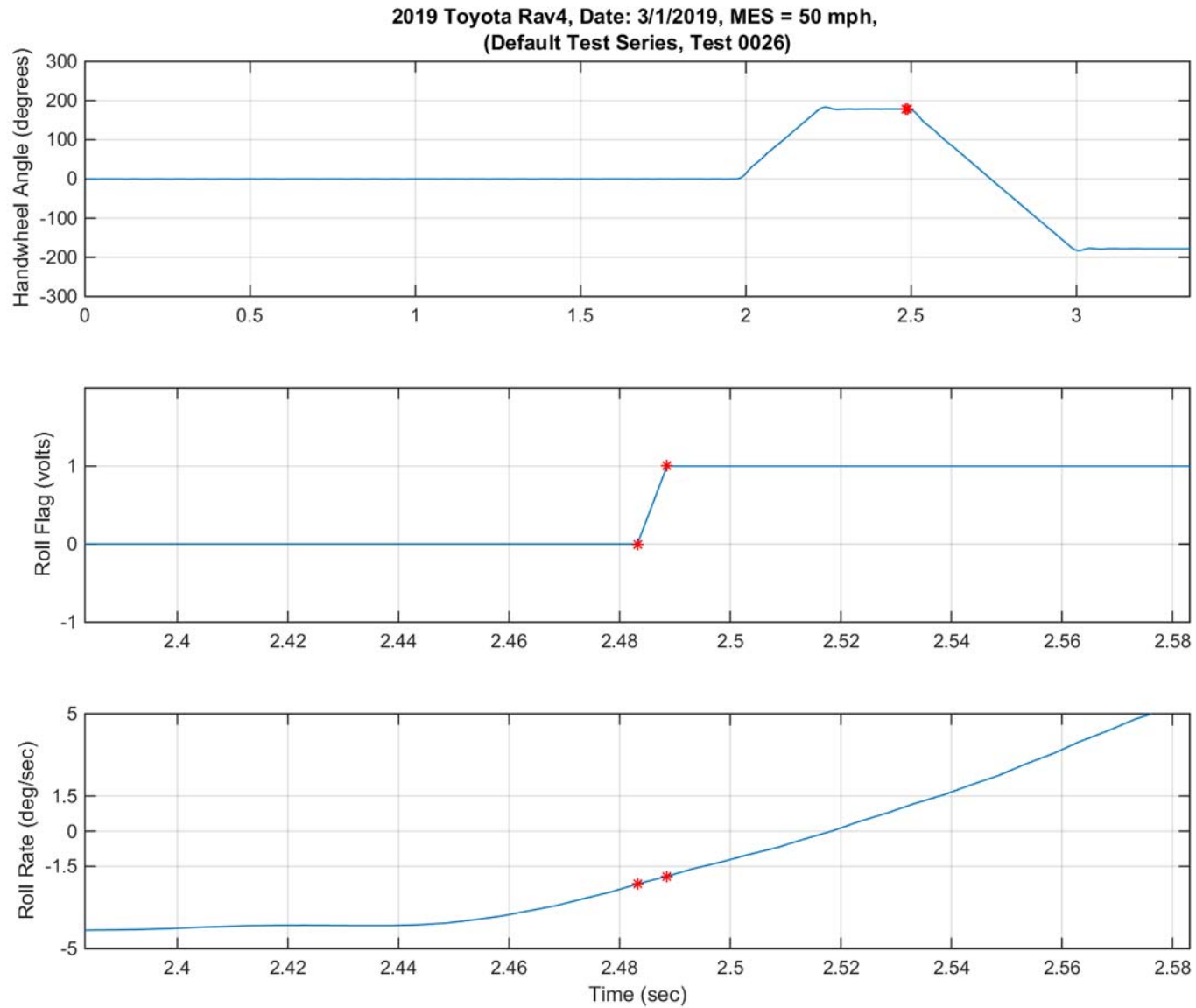

Figure D6. Steering Machine Operation Time History Plots for Default Test Series, R-L, 50 mph

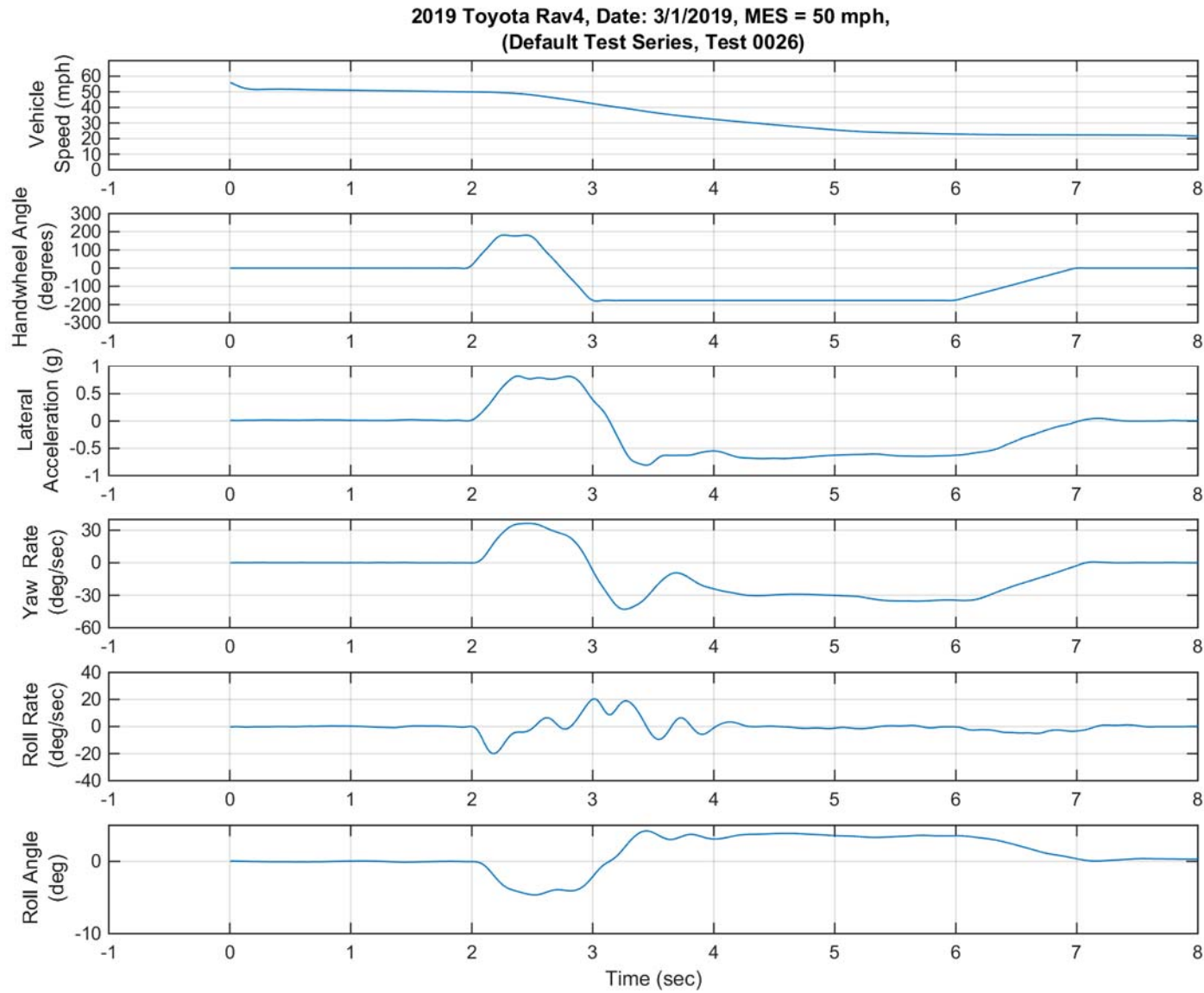

Figure D7. Yaw Rate, Roll Rate, and Lateral Acceleration Time History Plots for Default Test Series, R-L, 50 mph

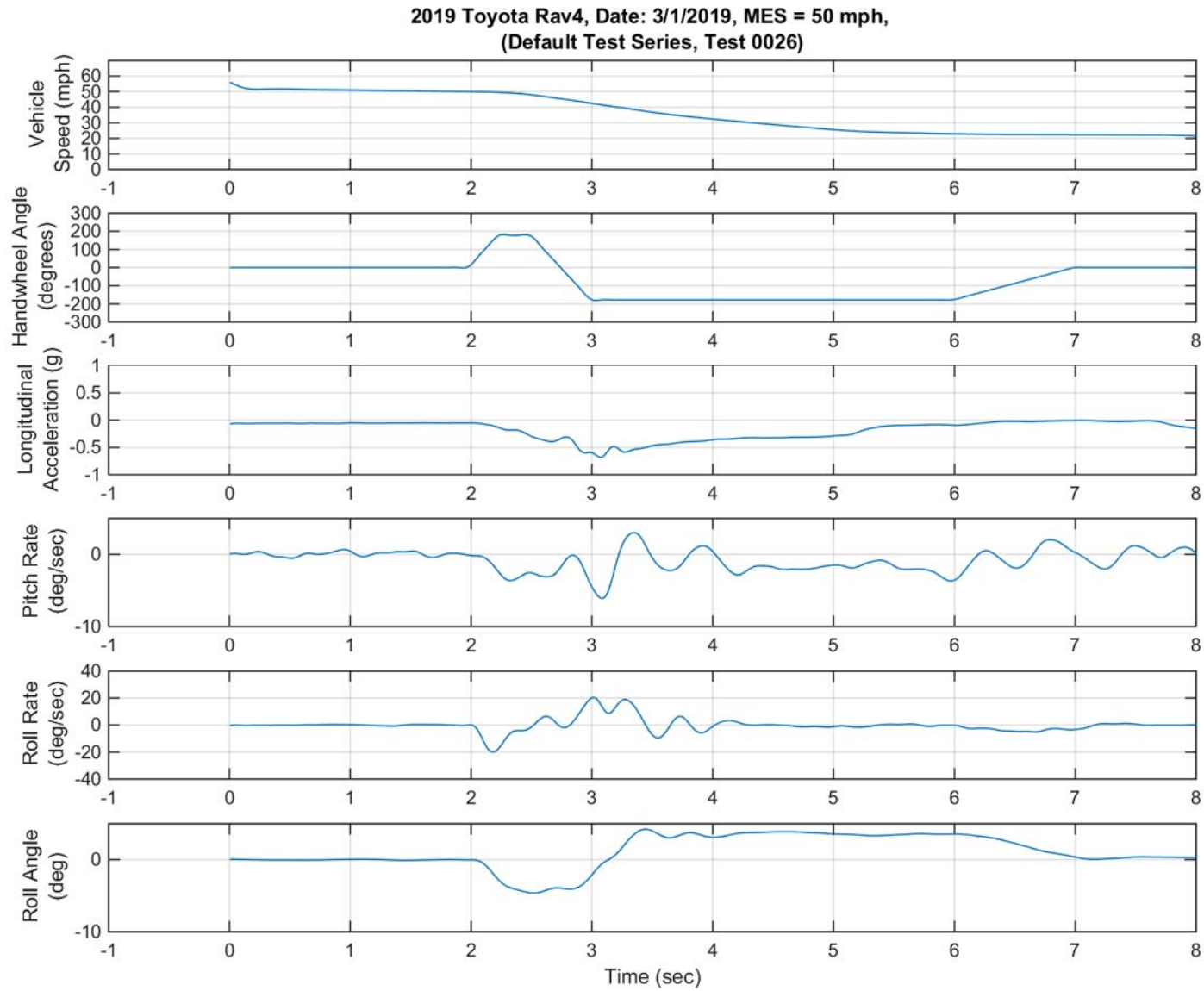

Figure D8. Pitch Rate and Longitudinal Acceleration Time History Plots or Default Test Series, R-L, 50 mph

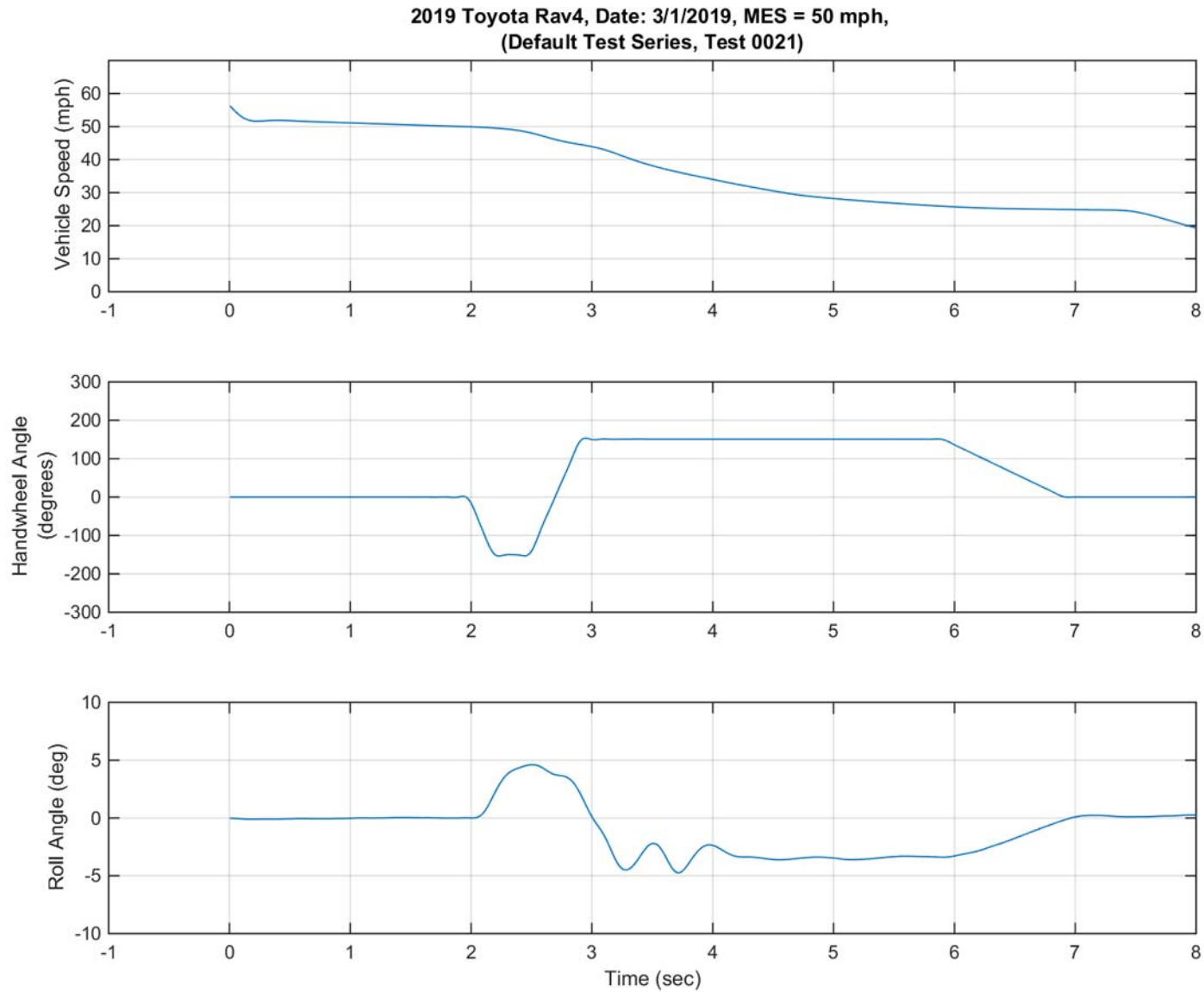

Figure D9. Vehicle Speed, Handwheel Angle, and Roll Angle Time History Plots for Supplemental 2 Test Series, L-R, 50 mph



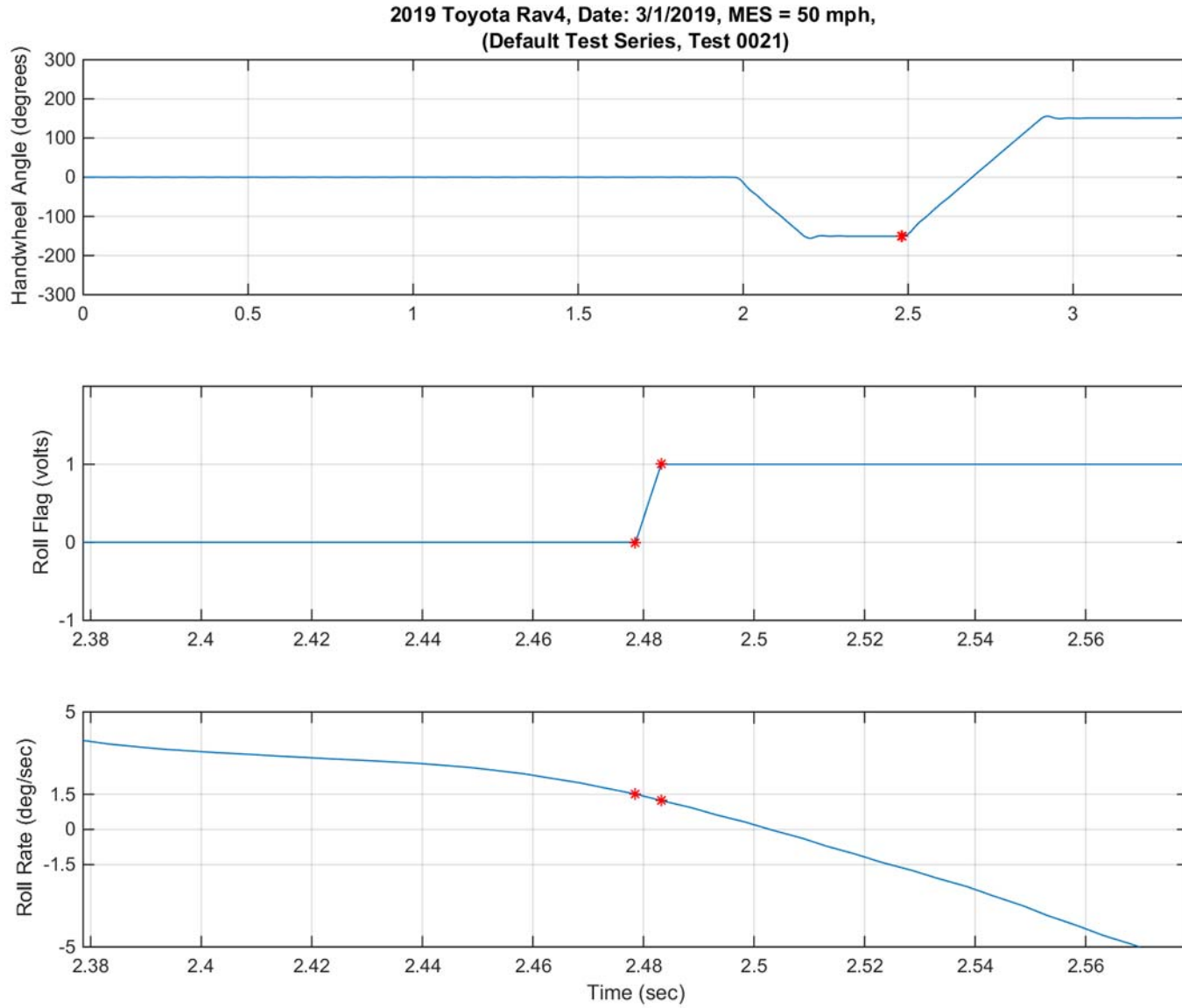

Figure D10. Steering Machine Operation Time History Plots for Supplemental 2 Test Series, L-R, 50 mph

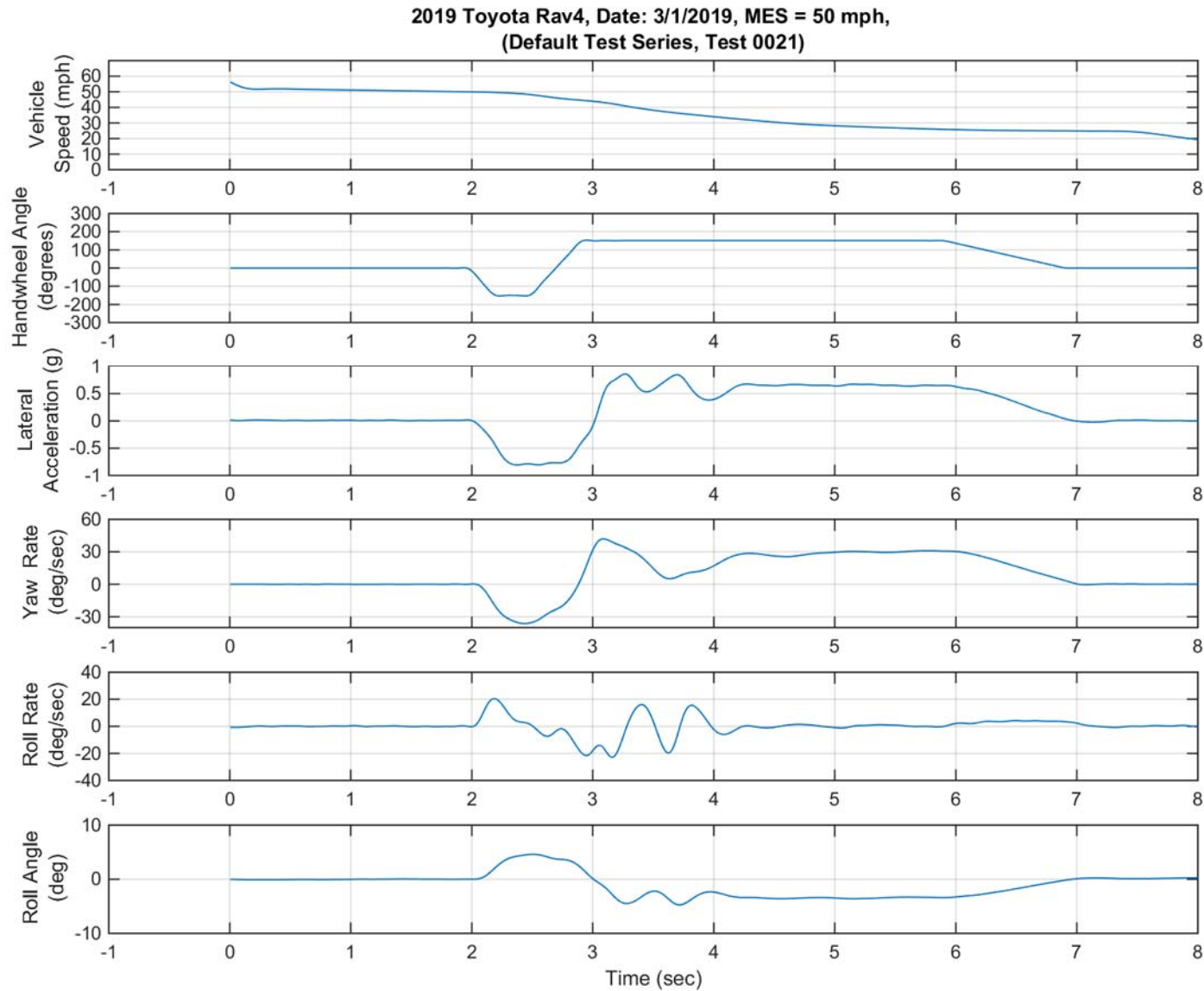

Figure D11. Yaw Rate, Roll Rate, and Lateral Acceleration Time History Plots for Supplemental 2 Test Series, L-R, 50 mph

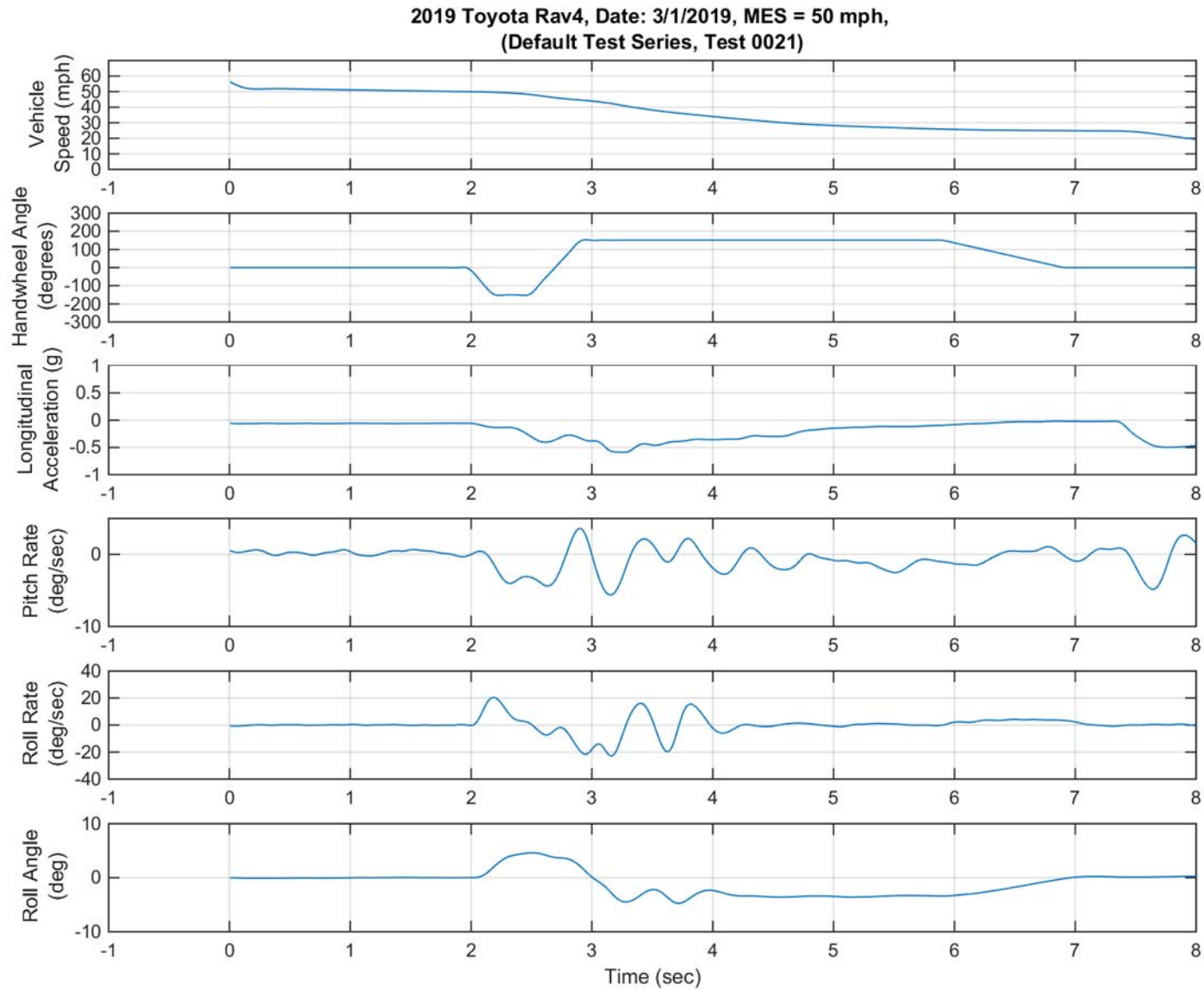

Figure D12. Pitch Rate and Longitudinal Acceleration Time History Plots for Supplemental 2 Test Series, L-R, 50 mph

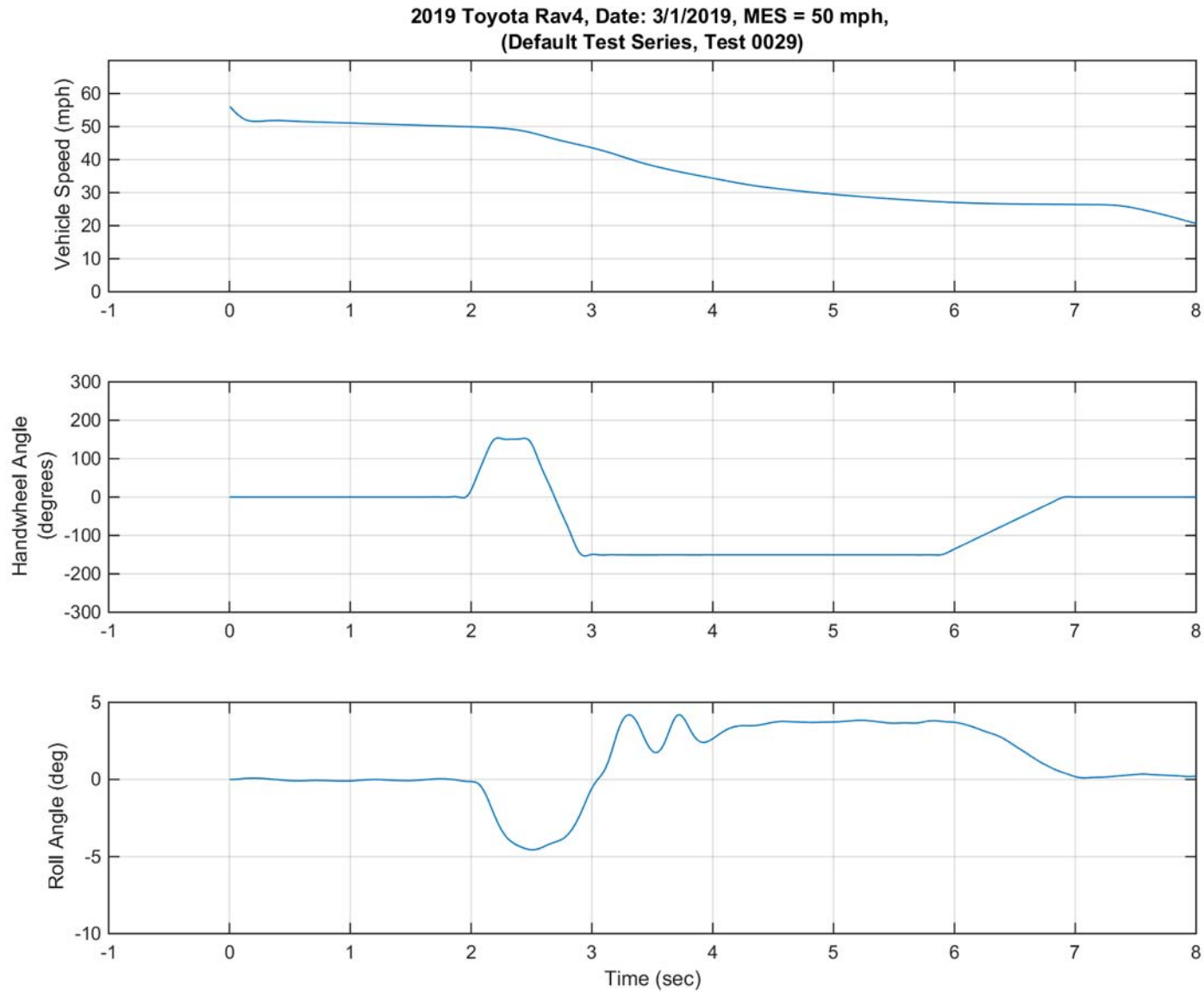

Figure D13. Vehicle Speed, Handwheel Angle, and Roll Angle Time History Plots for Supplemental 2 Test Series, R-L, 50 mph

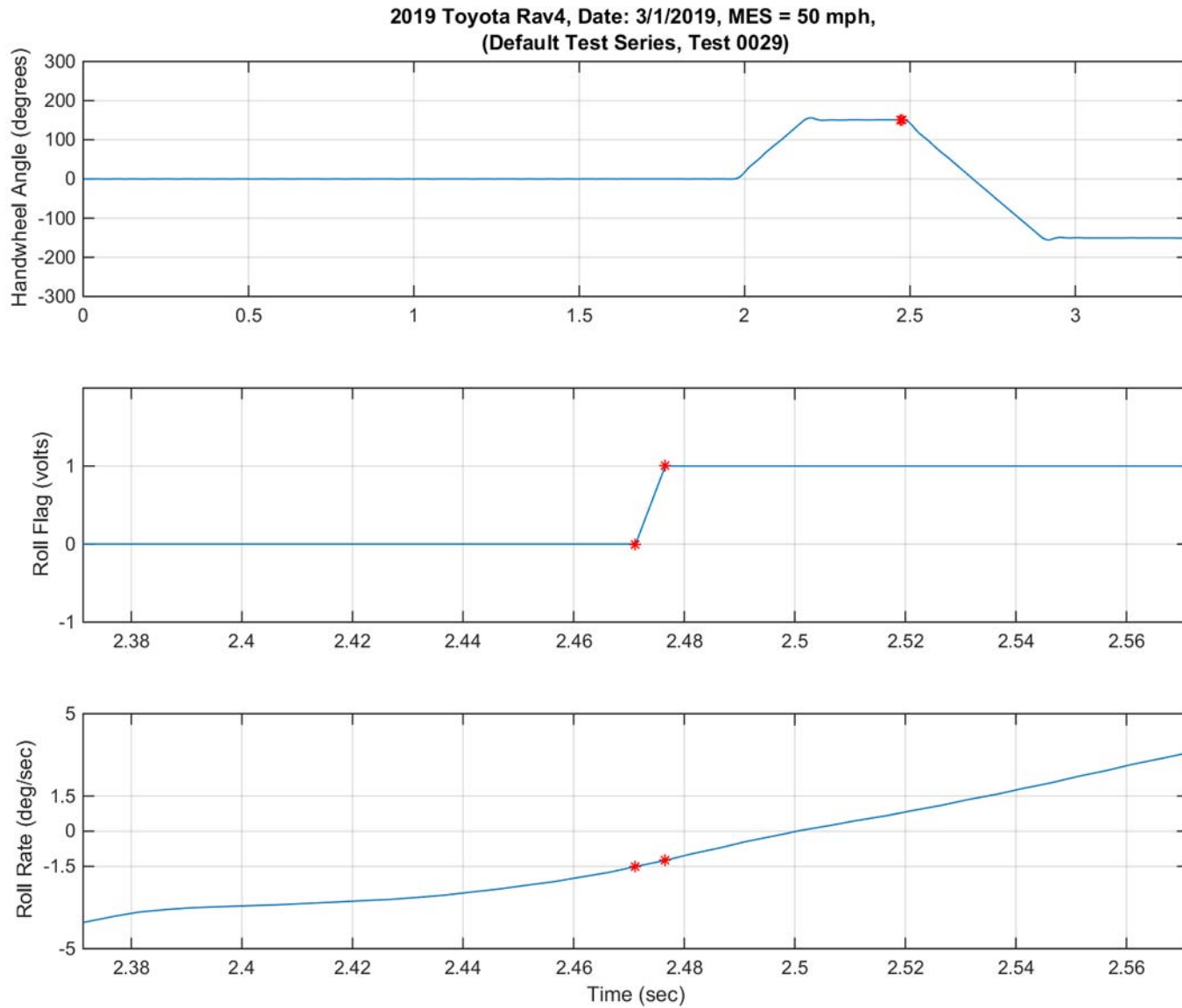

Figure D14. Steering Machine Operation Time History Plots for Supplemental 2 Test Series, R-L, 50 mph

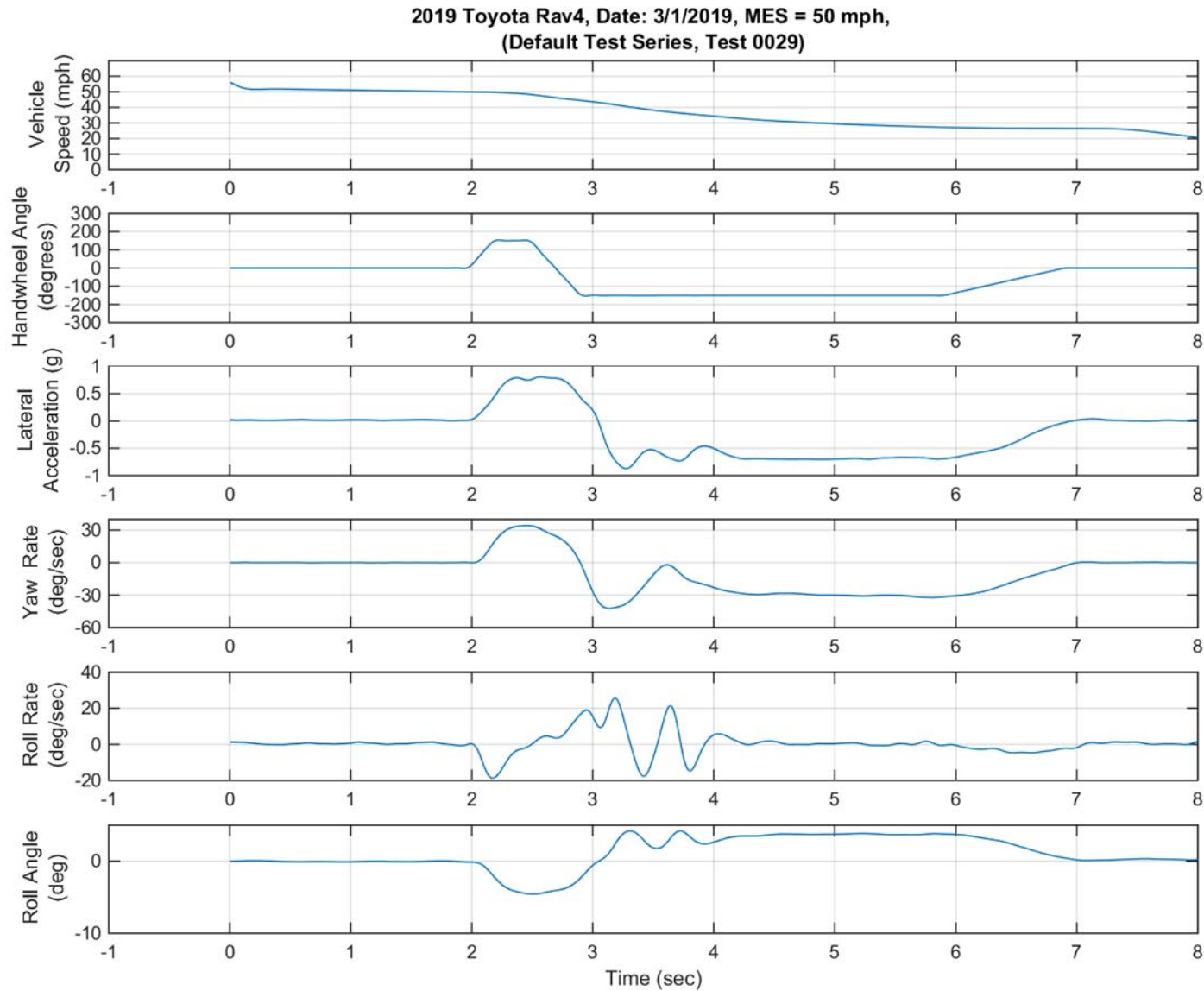

Figure D15. Yaw Rate, Roll Rate, and Lateral Acceleration Time History Plots for Supplemental 2 Test Series, R-L, 50 mph

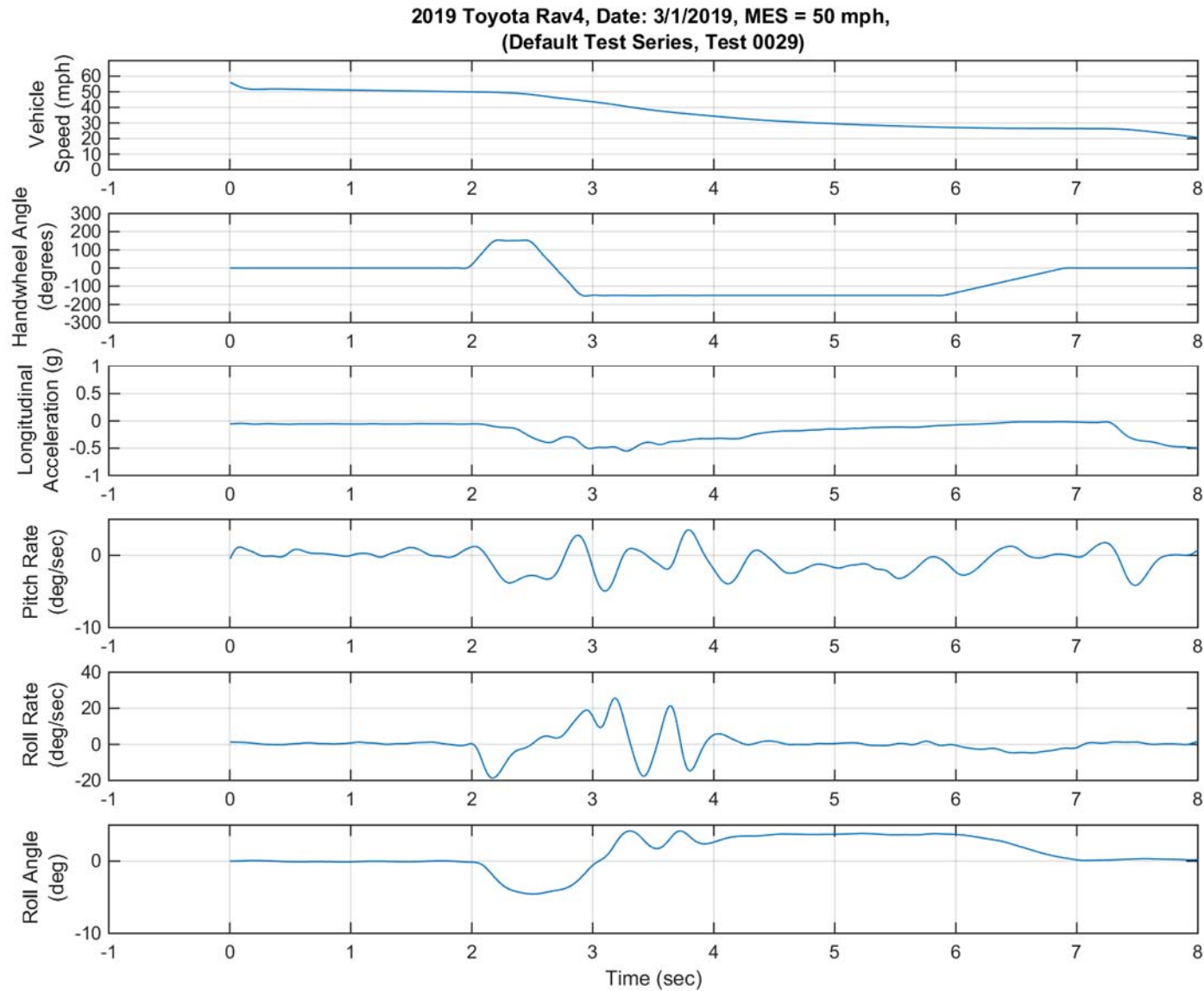

Figure D16. Pitch Rate and Longitudinal Acceleration Time History Plots for Supplemental 2 Test Series, R-L, 50 mph