

REPORT NUMBER: NCAP-KAR-19-019

**NEW CAR ASSESSMENT PROGRAM (NCAP)
FRONTAL BARRIER IMPACT TEST**

**NISSAN MOTOR CO., LTD.
2019 NISSAN KICKS S 5-DOOR SUV**

NHTSA NUMBER: M20195206

**PREPARED BY:
APPLUS IDIADA KARCO ENGINEERING, LLC.
9270 HOLLY ROAD
ADELANTO, CA 92301**

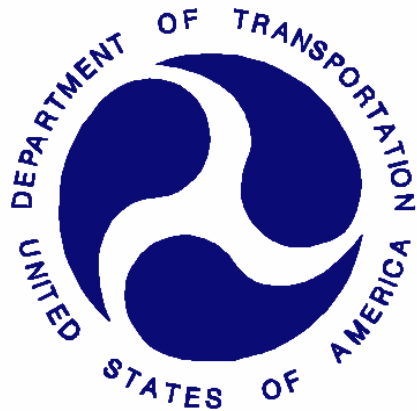

MARCH 25, 2019

FINAL REPORT

**U.S. DEPARTMENT OF TRANSPORTATION
NATIONAL HIGHWAY TRAFFIC SAFETY ADMINISTRATION
OFFICE OF CRASHWORTHINESS STANDARDS
1200 NEW JERSEY AVE, SE
ROOM W43-410
WASHINGTON, DC 20590**

This publication is distributed by the U.S. Department of Transportation, National Highway Traffic Safety Administration, in the interest of information exchange. The opinions, findings and conclusions expressed in this publication are those of the author(s) and not necessarily those of the Department of Transportation or the National Highway Traffic Safety Administration. The United States Government assumes no liability for its contents or use thereof. If trade or manufacturers' names or products are mentioned, it is only because they are considered essential to the object of the publication and should not be construed as an endorsement. The United States Government does not endorse products or manufacturers.

Prepared By:  _____

Mr. Malo L. Taua'ese, Engineering Technician
Applus IDIADA KARCO Engineering, LLC.

Reviewed By:  _____

Mr. Michael L. Dunlap, Director of Operations
Applus IDIADA KARCO Engineering, LLC.

Approved By:  _____

Mr. Steven D. Matsusaka, Engineering Manager
Applus IDIADA KARCO Engineering, LLC.

Approval Date: _____ March 25, 2019 _____

FINAL REPORT ACCEPTANCE BY OCWS:

Division Chief, New Car Assessment Program
NHTSA, Office of Crashworthiness Standards

Date: _____

COTR, New Car Assessment Program
NHTSA, Office of Crashworthiness Standards

Date: _____

TECHNICAL REPORT DOCUMENTATION PAGE

1. Report No. NCAP-KAR-19-019	2. Government Accession No.	3. Recipient's Catalog No.																																																					
4. Title and Subtitle Final Report of New Car Assessment Program Testing of a 2019 Nissan Kicks S 5-Door SUV NHTSA No. M20195206		5. Report Date March 25, 2019																																																					
		6. Performing Organization Code KAR																																																					
7. Authors Mr. Malo L. Taua'ese, Engineering Technician, Applus IDIADA KARCO Mr. Steven D. Matsusaka, Engineering Manager, Applus IDIADA KARCO		8. Performing Organization Report No. TR-P39033-01-NC																																																					
		10. Work Unit No.																																																					
9. Performing Organization Name and Address Applus IDIADA KARCO Engineering, LLC. 9270 Holly Rd. Adelanto, CA 92301		11. Contract or Grant No. DTNH22-12-D-00259																																																					
		13. Type of Report and Period Covered Final Test Report, March 11 - 25, 2019																																																					
12. Sponsoring Agency Name and Address U. S. Department of Transportation National Highway Traffic Safety Administration Office of Crashworthiness Standards 1200 New Jersey Ave., SE, Room W43-410 Washington, D.C. 20590		14. Sponsoring Agency Code NRM-110																																																					
		15. Supplementary Notes																																																					
16. Abstract A 56.3 km/h NCAP Frontal Impact Test was conducted on a 2019 Nissan Kicks S 5-door SUV in accordance with the specifications of the Office of Crashworthiness Standards Frontal NCAP Laboratory Test Procedure. This test was conducted to obtain data indicant of FMVSS 208, 212, 219 (partial), 301, and footwell intrusion performance. The test was conducted at the Applus IDIADA KARCO Engineering, LLC. facility in Adelanto, California on March 11, 2019. The impact velocity of the vehicle was 56.48 km/h and the ambient temperature at the barrier face at the time of impact was 13.9°C. The target vehicle's post-test maximum crush was 435 mm at DPD 4 right of the vehicle's centerline. The test vehicle's performance is as follows:																																																							
<table border="1" style="width: 100%; border-collapse: collapse;"> <thead> <tr> <th rowspan="2">Measurement Description</th> <th rowspan="2">Units</th> <th colspan="2">Driver ATD</th> <th colspan="2">Passenger ATD</th> </tr> <tr> <th>Threshold</th> <th>Result</th> <th>Threshold</th> <th>Result</th> </tr> </thead> <tbody> <tr> <td>Head Injury Criteria (HIC₁₅)</td> <td>N/A</td> <td>700</td> <td>224.3</td> <td>700</td> <td>197.7</td> </tr> <tr> <td>Maximum Chest Compression</td> <td>mm</td> <td>63</td> <td>-24</td> <td>52</td> <td>-11</td> </tr> <tr> <td>Nij</td> <td>N/A</td> <td>1</td> <td>0.29</td> <td>1</td> <td>0.59</td> </tr> <tr> <td>Neck Tension</td> <td>N</td> <td>4170</td> <td>1631.6</td> <td>2620</td> <td>1278.6</td> </tr> <tr> <td>Neck Compression</td> <td>N</td> <td>4000</td> <td>-335.6</td> <td>2520</td> <td>-871.3</td> </tr> <tr> <td>Left Femur Force</td> <td>N</td> <td>10000</td> <td>-856.8</td> <td>6800</td> <td>-1302.8</td> </tr> <tr> <td>Right Femur Force</td> <td>N</td> <td>10000</td> <td>-741.7</td> <td>6800</td> <td>-1753.8</td> </tr> </tbody> </table>				Measurement Description	Units	Driver ATD		Passenger ATD		Threshold	Result	Threshold	Result	Head Injury Criteria (HIC ₁₅)	N/A	700	224.3	700	197.7	Maximum Chest Compression	mm	63	-24	52	-11	Nij	N/A	1	0.29	1	0.59	Neck Tension	N	4170	1631.6	2620	1278.6	Neck Compression	N	4000	-335.6	2520	-871.3	Left Femur Force	N	10000	-856.8	6800	-1302.8	Right Femur Force	N	10000	-741.7	6800	-1753.8
Measurement Description	Units	Driver ATD				Passenger ATD																																																	
		Threshold	Result	Threshold	Result																																																		
Head Injury Criteria (HIC ₁₅)	N/A	700	224.3	700	197.7																																																		
Maximum Chest Compression	mm	63	-24	52	-11																																																		
Nij	N/A	1	0.29	1	0.59																																																		
Neck Tension	N	4170	1631.6	2620	1278.6																																																		
Neck Compression	N	4000	-335.6	2520	-871.3																																																		
Left Femur Force	N	10000	-856.8	6800	-1302.8																																																		
Right Femur Force	N	10000	-741.7	6800	-1753.8																																																		
17. Key Words 35 mph Frontal Barrier Impact Test New Car Assessment Program (NCAP)		18. Distribution Statement Copies of this report are available from: National Highway Traffic Safety Administration Technical Information Services Division, NPO-411 1200 New Jersey Ave., SE Washington, DC 20590 e-mail: tis@nhtsa.dot.gov FAX: 202-493-2833																																																					
19. Security Classification of this report UNCLASSIFIED	20. Security Classification of this page UNCLASSIFIED	21. No. of Pages 136	22. Price																																																				

TABLE OF CONTENTS

<u>Section</u>		<u>Page No.</u>
1	Purpose and Summary of Test	1
2	Occupant and Vehicle Information / Data Sheets	3
<u>Data Sheet No.</u>		<u>Page No.</u>
1	General Test and Vehicle Parameter Data	4
2	Seat Adjustment, Fuel System, and Steering Wheel Data	8
3	Dummy Longitudinal Clearance Dimensions	10
4	Dummy Lateral Clearance Dimensions	11
5	Seat Belt Positioning Data	12
6	High-Speed Camera Locations and Data	13
7	Vehicle Accelerometer Locations	15
8	Photographic Reference Target Locations	16
9	Load Cell Locations on Fixed Barrier	17
10	Test Vehicle Camera and Instrumentation Summary	18
11	Post-Test Observations	19
12	Vehicle Profile Measurements	20
13	Accident Investigation Division Data	22
14	Vehicle Intrusion Measurements	23
15	Summary of FMVSS 212, 219 (Partial), and 301 Data	25
16	FMVSS 301 Static Rollover Results	27
17	Dummy / Vehicle Temperature Stabilization Chart	28
<u>Appendix</u>		<u>Page No.</u>
A	Photographs	A
B	Dummy Response Data Traces	B
C	ATD Calibration and Performance Verification Data	C

SECTION 1

PURPOSE AND SUMMARY OF TEST

PURPOSE

This 56.3 km/h frontal barrier impact test is part of the Vehicle Barrier Impact Testing Program, sponsored by the National Highway Traffic Safety Administration (NHTSA) under contract number DTNH22-12-D-00259. The purpose of this test was to obtain vehicle crashworthiness and occupant restraint system performance data for consumer information purposes.

The 56.3 km/h frontal barrier impact test was conducted in accordance with the Office of Crashworthiness Standards Frontal NCAP Laboratory Test Procedure, dated October 2015.

SUMMARY

A load cell barrier consisting of 176 load cells was impacted by a 2019 Nissan Kicks S 5-door SUV at a velocity of 56.48 km/h. The test was performed at Applus IDIADA KARCO Engineering, LLC. on March 11, 2019. Pre- and post-test photographs of the vehicle and dummies can be found in Appendix A of this report.

Three (3) real-time cameras and sixteen (16) high-speed cameras were used to document the frontal barrier impact event. Camera locations and other pertinent camera information can be found in Data Sheet 6 of this report.

One Part 572E 50th percentile male anthropomorphic test device (ATD) was placed in the driver seating position and one Part 572O 5th percentile female ATD was placed in the right-front passenger seating position according to dummy placement instructions specified in the Frontal NCAP Laboratory Test Procedure.

Both ATDs were fully instrumented with head, chest and pelvis tri-axial accelerometers, chest displacement potentiometers, upper neck force transducers, right / left femur load cells, and lower leg instrumentation. The driver (position 1) ATD (Serial No. 360) and the right-front passenger (position 2) ATD (Serial No. 141) were calibrated prior to this test. Certification details, along with instrumentation calibration data, are found in Appendix C of this report.

The 102 channels of dummy and vehicle response data were recorded on an on-board data acquisition system. Appendix B contains the dummy response data traces.

There was 100% windshield retention and no intrusion into the protected zone of the windshield during the event.

The maximum static crush was 435 mm at DPD 4 right of the vehicle's centerline. Both the driver and passenger side doors remained closed during the impact event and were operable after the impact.

The driver's visible contact points were as follows: The driver ATD's head contacted the frontal airbag and headrest. The upper torso contacted the frontal airbag. The left knee contacted the knee bolster. The right knee contacted the steering column and knee bolster.

The passenger's visible contact points were as follows: The passenger ATD's head contacted the frontal airbag and headrest. The upper torso contacted the frontal airbag. Both left and right knees contacted the knee bolster.

The occupant data is summarized below:

ATD Position	HIC ₁₅	T ¹ (ms)	T ² (ms)	Chest Disp. (mm)	Nij	Neck Tension (N)	Neck Comp. (N)	Left Femur (N)	Right Femur (N)
Driver (50th)	224.3	71.8	86.8	-24	0.29	1631.6	-335.6	-856.8	-741.7
Passenger (5th)	197.7	64.5	79.5	-11	0.59	1278.6	-871.3	-1302.8	-1753.8

SECTION 2

OCCUPANT AND VEHICLE INFORMATION / DATA SHEETS

Test Vehicle: 2019 Nissan Kicks S 5-Door SUV NHTSA No.: M20195206

Test Program: 56.3 km/h Frontal Impact NCAP Test Test Date: 03/11/19

CONVERSION FACTORS

Quantity	Typical Application	Std Units	Metric Unit	Multiply By
Mass	Vehicle Weight	lb	kg	0.4536
Linear Velocity	Impact Velocity	miles/hr	km/hr	1.609344
Length or Distance	Measurements	in	mm	25.4
Volume	Fuel Systems	gal	liter	3.785
Volume	Small Fluids	oz	mL	29.574
Pressure	Tire Pressures	lb/in ²	kPa	6.895
Temperature	General Use	°F	°C	$=(T_f - 32)/1.8$
Force	Dynamic Forces	lbf	N	4.448
Moment	Torque	lbf-ft	N•m	1.355

DATA SHEET NO. 1

GENERAL TEST AND VEHICLE PARAMETER DATA

Test Vehicle: 2019 Nissan Kicks S 5-Door SUV NHTSA No.: M20195206
 Test Program: 56.3 km/h Frontal Impact NCAP Test Test Date: 03/11/19

TEST VEHICLE INFORMATION AND OPTIONS

NHTSA Number	M20195206
Model Year	2019
Make	Nissan
Model	Kicks S
Body Style	5-Door SUV
VIN	3N1CP5CU9KL481704
Body Color	Gun Metallic
Odometer Reading (km / mi)	37 / 23
Engine Displacement (L)	1.6
Type / No. of Cylinders	Straight 4 Cylinders
Engine Placement	Transverse
Transmission Type	Automatic
Transmission Speeds	CVT
Overdrive	No
Final Drive	FWD
Roof Rack	Yes
Sunroof / T-Top	No
Running Boards	No
Tilt Steering Wheel	Yes
Power Seats	No
Anti-Lock Brakes (ABS)	Yes
Automatic Door Locks (ADLs)	Yes

Traction Control System	Yes
Power Steering	Yes
Power Window Auto-Reverse	Yes
Driver Frontal Airbag	Yes
Driver Curtain Airbag	Yes
Driver Head/Torso Airbag	No
Driver Torso Airbag	No
Driver Torso/Pelvis Airbag	Yes
Driver Pelvis Airbag	No
Driver Knee Airbag	Yes
Front Pass. Frontal Airbag	Yes
Front Pass. Curtain Airbag	Yes
Front Pass. Head/Torso Airbag	No
Front Pass. Torso Airbag	No
Front Pass. Torso/Pelvis Airbag	Yes
Front Pass. Pelvis Airbag	No
Front Pass. Knee Airbag	No
Driver Seat Belt Pretensioner	Yes
Driver Load Limiter	Yes
Front Pass. Seat Belt Pretensioner	Yes
Front Pass. Load Limiter	Yes
Other Safety Restraint	No

Does Owner's Manual provide instructions to turn off automatic door locks?

No

DATA FROM CERTIFICATION LABEL

Manufactured By	Nissan Motor Co., LTD.
Date of Manufacture	Nov-18

GVWR (kg)	1633
GAWR Front (kg)	863
GAWR Rear (kg)	770

VEHICLE SEATING AND CAPACITY WEIGHT INFORMATION

Measured Parameter	Front	Rear	Third	Total
Type of Seats	Bucket	Split Bench		
Designated Seating Capacity	2	3		5
Capacity Weight (VCW) (kg)				385.0
DSC x 68.04 (kg)				340.2
Cargo Weight (RCLW) (kg)				44.8

A

B

A-B

DATA SHEET NO. 1 ... (CONTINUED)

GENERAL TEST AND VEHICLE PARAMETER DATA

Test Vehicle: 2019 Nissan Kicks S 5-Door SUV NHTSA No.: M20195206
 Test Program: 56.3 km/h Frontal Impact NCAP Test Test Date: 03/11/19

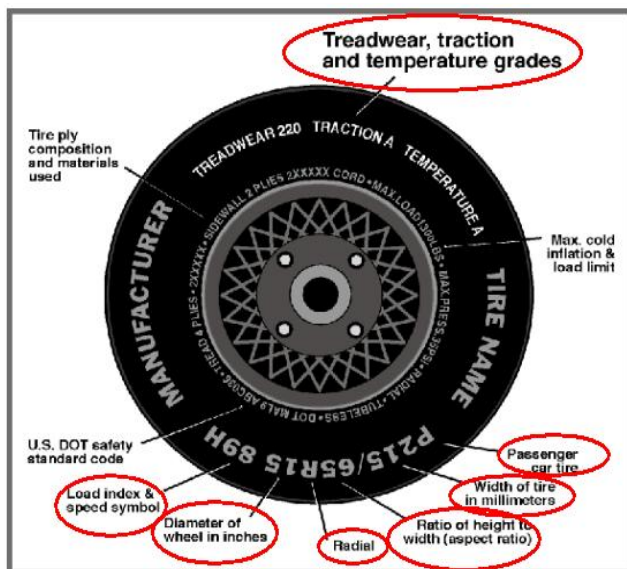

VEHICLE TIRE INFORMATION

Measured Parameter	Front	Rear
Max. Tire Pressure (kPa)	300	300
Cold Pressure (kPa)	220	220
Recommended Tire Size	P205/60R16	P205/60R16
Tire Size on Vehicle	P205/60R16	P205/60R16
Tire Manufacturer	Firestone	Firestone
Tire Model	FT140	FT140
Treadwear	500	500
Traction	A	A
Temperature Grades	A	A
Tire Plies Sidewall	1 Polyester	1 Polyester
Tire Plies Body	1 Polyester, 2 Steel, 1 Nylon	1 Polyester, 2 Steel, 1 Nylon
Load Index / Speed Symbol	92H	92H
Tire Material	Polyester, Steel, Nylon	Polyester, Steel, Nylon
DOT Safety Code Left	V6XW FTO 3318	V6XW FTO 3318
DOT Safety Code Right	V6XW FTO 3318	V6XW FTO 3318

DATA SHEET NO. 1 ... (CONTINUED)

GENERAL TEST AND VEHICLE PARAMETER DATA

Test Vehicle: 2019 Nissan Kicks S 5-Door SUV NHTSA No.: M20195206
 Test Program: 56.3 km/h Frontal Impact NCAP Test Test Date: 03/11/19

TEST VEHICLE WEIGHTS

	Units	As Delivered Weights (UWV)			As Tested Weights (ATW)		
		Front Axle	Rear Axle	Total	Front Axle	Rear Axle	Total
Left	kg	373.0	233.5		407.0	300.5	
Right	kg	356.0	229.0		386.5	276.5	
Ratio	%	61.2%	38.8%	100.0%	57.9%	42.1%	100.0%
Total	kg	729.0	462.5	1191.5	793.5	577.0	1370.5

TARGET TEST WEIGHT CALCULATION

Measured Parameter	Units	Value	
Total Delivered Weight (UWV)	kg	1191.5	A
Weight of 1 P572E ATD & 1 P572O ATD	kg	141.0	B
Rated Cargo/Luggage Weight (RCLW)	kg	44.8	C
Calculated Vehicle Target Weight (TVTW)	kg	1377.3	A+B+C

TEST VEHICLE ATTITUDES

Condition	Units	LF	RF	LR	RR	CG Aft of Front Axle
As Delivered	mm	804	809	820	835	1016
As Tested	mm	786	795	798	807	1102
Post-Test	mm	760	760	801	787	

GENERAL TEST VEHICLE DATA

Measurement Description	Units	Value
Total Vehicle Wheelbase	mm	2618
Total Vehicle Length at Left Side	mm	3661
Total Vehicle Length at Centerline	mm	4297
Total Vehicle Length at Right Side	mm	3660
Weight of Ballast in Cargo Area	kg	51.0
Weight of Vehicle Components Removed	kg	13.0
Amount of Stoddard Solvent in Fuel Tank	L	38.02

VEHICLE COMPONENTS REMOVED TO MEET TEST WEIGHT:

Rear Trim and tools (13.0 kg)

DATA SHEET NO. 1 ... (CONTINUED)

GENERAL TEST AND VEHICLE PARAMETER DATA

Test Vehicle: 2019 Nissan Kicks S 5-Door SUV NHTSA No.: M20195206
Test Program: 56.3 km/h Frontal Impact NCAP Test Test Date: 03/11/19

TARGET VEHICLE STRUCTURAL MEASUREMENTS

No.	Description	Pre-Test
1	Total Length	4297
2	Total Width	1760
3	Bumper Top Height	710
4	Bumper Bottom Height	328
5	Longitudinal Member Top Height	600
6	Distance Between Longitudinal Members	880
7	Longitudinal Member Width	50
8	Engine Top Height	798
9	Engine Bottom Height	196
10	Engine and Gearbox Width	380
11	Front Bumper to Engine Distance	457
12	Front Shock Absorber Fixing Height	901
13	Bonnet Leading Edge Height	849
14	Front Shock Absorber Fixing Width	1130
15	Front Bumper to Front Axle Distance	865
16	Front Axle to A-Pillar Distance	450
17	A-Pillar to B-Pillar Distance	971
18	B-Pillar to Rear Axle Distance	1102
19	B-Pillar to C-Pillar Distance	883
20	Roof Sill Bottom Height	1423
21	Roof Sill Top Height	1530
22	Floor Sill Bottom Height	344
23	Floor Sill Top Height	282

All measurements in millimeters.

DATA SHEET NO. 2

SEAT ADJUSTMENT, FUEL SYSTEM, AND STEERING WHEEL DATA

Test Vehicle: 2019 Nissan Kicks S 5-Door SUV NHTSA No.: M20195206
 Test Program: 56.3 km/h Frontal Impact NCAP Test Test Date: 03/11/19

NOMINAL DESIGN RIDING POSITION

The procedure for the driver is as follows: the seat back is set to the manufacturer’s designated angle. The procedure for the passenger is as follows: the seat back is set to position the transverse instrumentation platform of the dummy’s head at $0^\circ \pm 0.5^\circ$. Seat back angle is measured at the headrest post.

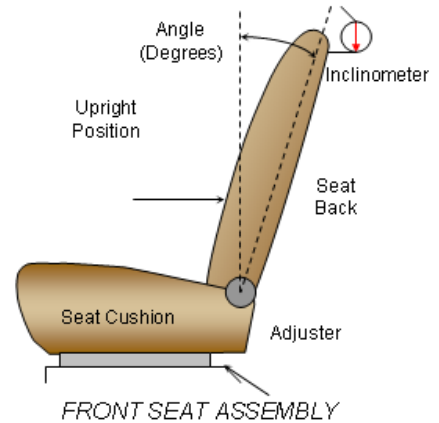

SEAT BACK ANGLE

Seating Position	Degrees
Driver Seat Back Angle	4.4
Passenger Seat Back Angle	1.7

SEAT FORE / AFT POSITIONING

The total seat travel is measured from the forward most possible position to the rear most possible position. The driver’s seat is set to the middle of the fore-aft travel. The passenger’s seat is set to the forward most position where the ATD will not contact any interior panels.

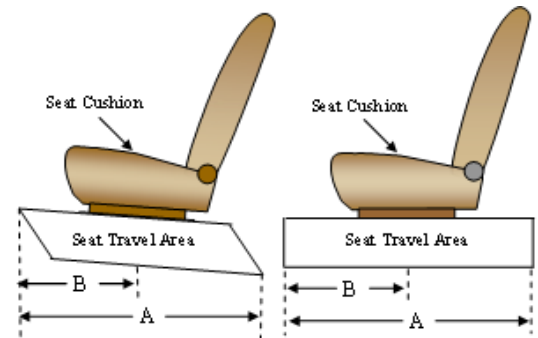

SEAT FORE/AFT POSITIONS

Seating Position	Total Fore-Aft Travel	Placed in Position
Driver Seat	275 mm	113 mm
Passenger Seat	240 mm	0 mm

SEAT BELT UPPER ANCHORAGE

The seat belt upper anchorage is positioned to the manufacturer’s design position for a 50th percentile adult male ATD for the driver, and a 5th percentile adult female ATD for the passenger. Position “H” is the uppermost position, followed by position “M”, and Position “L” is the lowermost position.

SEAT BELT UPPER ANCHORAGES

Seating Position	Total No. of Positions	Placed in Position
Driver Seat	4	H
Passenger Seat	4	H

DATA SHEET NO. 2 ... (CONTINUED)

SEAT ADJUSTMENT, FUEL SYSTEM, AND STEERING WHEEL DATA

Test Vehicle: 2019 Nissan Kicks S 5-Door SUV NHTSA No.: M20195206
 Test Program: 56.3 km/h Frontal Impact NCAP Test Test Date: 03/11/19

FUEL TANK CAPACITY

Description	Liters
Usable Capacity of "Standard Tank"	40.88
Usable Capacity of "Optional Tank"	
92 - 94% of Usable Capacity	37.61 to 38.43
Actual Amount of Stoddard Solvent Used	38.02
1/3 of Usable Capacity	13.63

FUEL PUMP

The vehicle is equipped with an electric fuel pump.
 The fuel pump starts when the ignition is on.

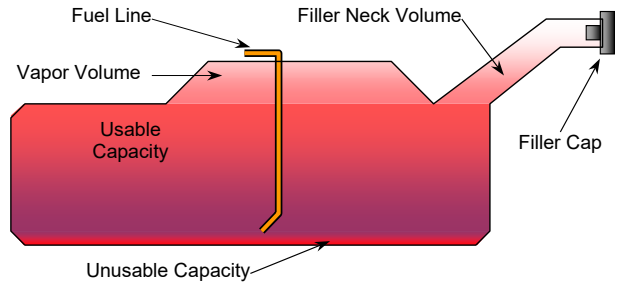

VEHICLE FUEL TANK ASSEMBLY

STEERING COLUMN ADJUSTMENT

Steering wheel and column adjustments are made so that the steering wheel hub is at the geometric center of the locus it describes when moved through its full range of motion. A digital inclinometer is used to measure a plate which is placed across the rim of the steering wheel for angular measurements.

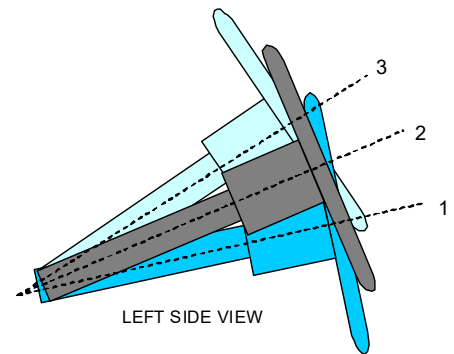

STEERING COLUMN ASSEMBLY

STEERING COLUMN POSITIONING

	Degrees	Fore-Aft Position (mm)
Lowermost Position, No. 1	22.9	89
Geometric Center Position, No. 2	25.2	107
Uppermost Position, No. 3	27.5	125
Telescoping Steering Wheel Travel		36
Test Position	25.2	107

DATA SHEET NO. 3

DUMMY LONGITUDINAL CLEARANCE DIMENSIONS

Test Vehicle: 2019 Nissan Kicks S 5-Door SUV NHTSA No.: M20195206

Test Program: 56.3 km/h Frontal Impact NCAP Test Test Date: 03/11/19

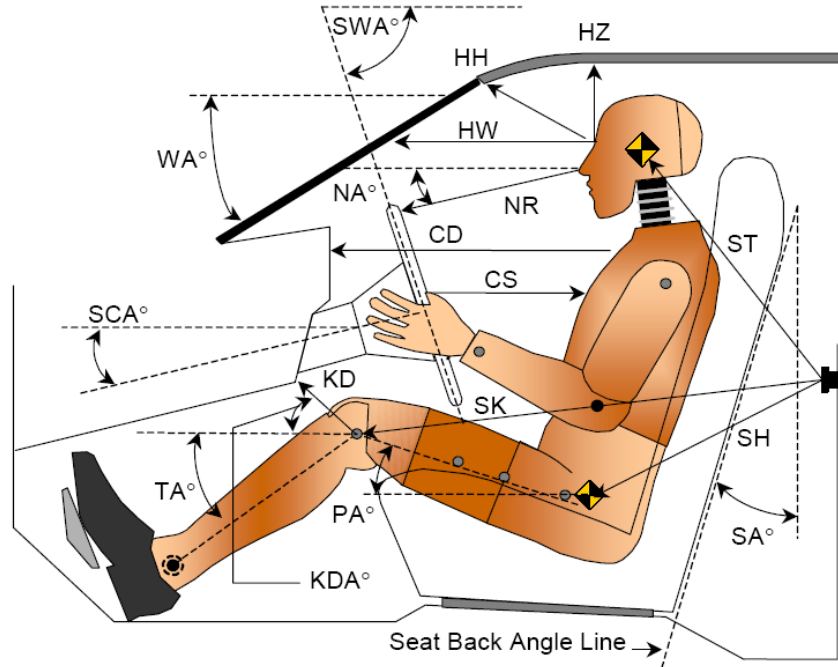

LEFT SIDE VIEW

Code	Measurement Description	Driver		Passenger	
		Length (mm)	Angle (°)	Length (mm)	Angle (°)
WA°	Windshield Angle		30.2		
SWA°	Steering Wheel Angle		64.8		
SCA°	Steering Column Angle		25.2		
SA°	Seat Back Angle (On Headrest Post)		4.4		1.7
HZ	Head to Roof	230	90.0	263	90.0
HH	Head to Header	364	27.8	310	25.2
HW	Head to Windshield	670	0.0	652	0.0
NR	Nose to Rim	420	12.6	477	26.5
CD	Chest to Dash	540	14.6	424	2.5
CS	Chest to Steering Hub	323	7.2		
RA	Rim to Abdomen	218	0.0		
KDL	Left Knee to Dash	145	38.1	78	37.0
KDR	Right Knee to Dash	130	26.8	107	33.6
PA°	Pelvic Angle		24.0		21.7
TA°	Tibia Angle		49.9		55.4
SK	Striker to Knee	555	6.1	645	2.2
ST	Striker to Head	570	87.7	506	70.2
SH	Striker to H-Point	193	29.2	409	41.9

DATA SHEET NO. 4

DUMMY LATERAL CLEARANCE DIMENSIONS

Test Vehicle: 2019 Nissan Kicks S 5-Door SUV NHTSA No.: M20195206

Test Program: 56.3 km/h Frontal Impact NCAP Test Test Date: 03/11/19

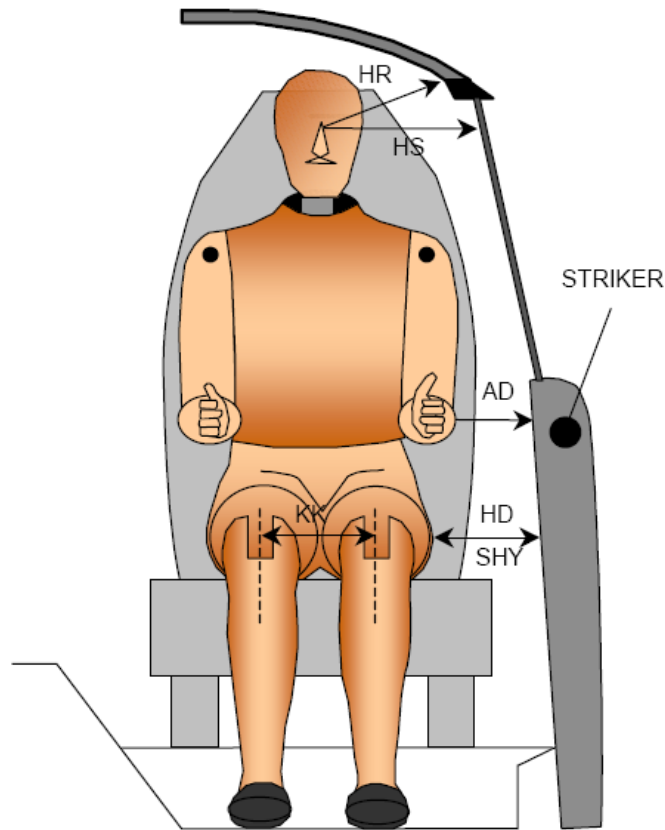

Code	Description	Driver (mm)	Passenger (mm)
AD	Arm to Door	99	60
HD	H-Point to Door	140	166
HR	Head to Side Header	236	273
HS	Head to Side Window	365	375
KK	Knee to Knee	300	170
SHY	Striker to H-Point (Y-Direction)	244	273
AA	Ankle to Ankle	245	180

DATA SHEET NO. 5
SEAT BELT POSITIONING DATA

Test Vehicle: 2019 Nissan Kicks S 5-Door SUV NHTSA No.: M20195206
 Test Program: 56.3 km/h Frontal Impact NCAP Test Test Date: 03/11/19

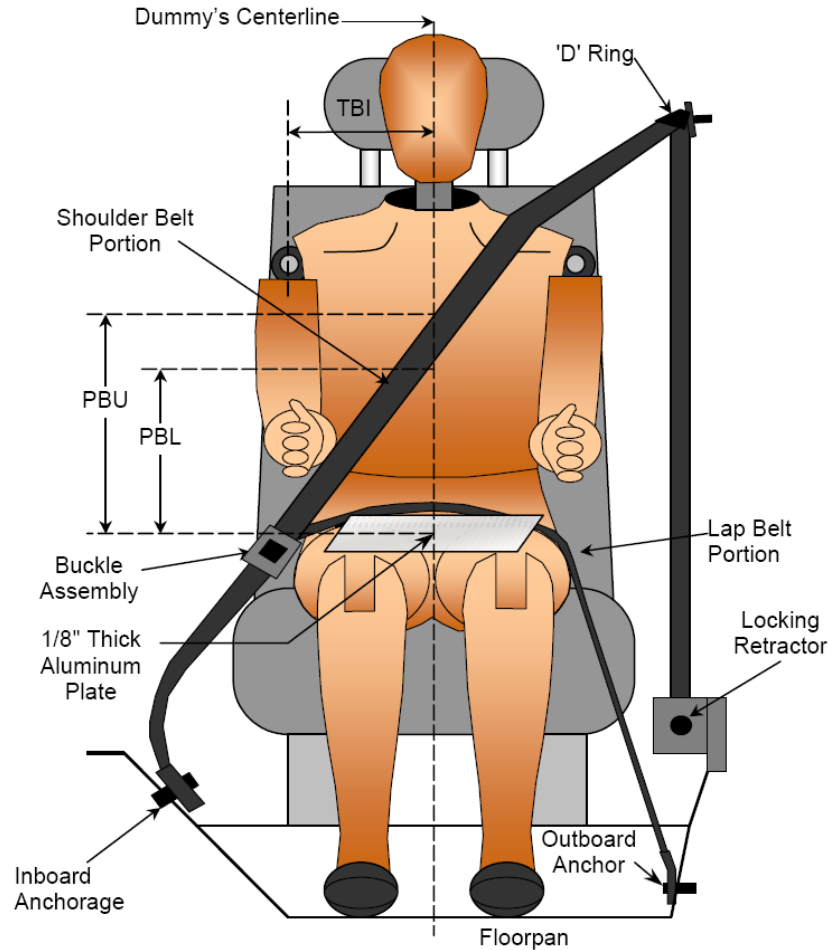

FRONT VIEW OF DUMMY

SEAT BELT POSITIONING MEASUREMENTS

Code	Measurement Description	Units	Driver	Passenger
PBU	Top Surface of Aluminum Plate to Belt Upper Edge	mm	305	305
PBL	Top Surface of Aluminum Plate to Belt Lower Edge	mm	385	225

BELT LENGTH DATA

Measurement Description	Units	Driver	Passenger
Shoulder Belt Length as Measured on ATD	mm	810	906
Lap Belt Length as Measured on ATD	mm	685	733
Remainder of Belt on Reel	mm	1180	750
Total Belt Length for Continuous Webbing Systems	mm	2675	2389

DATA SHEET NO. 6

HIGH-SPEED CAMERA LOCATIONS AND DATA

Test Vehicle: 2019 Nissan Kicks S 5-Door SUV NHTSA No.: M20195206

Test Program: 56.3 km/h Frontal Impact NCAP Test Test Date: 03/11/19

CAMERA POSITIONS FOR FRONTAL IMPACTS

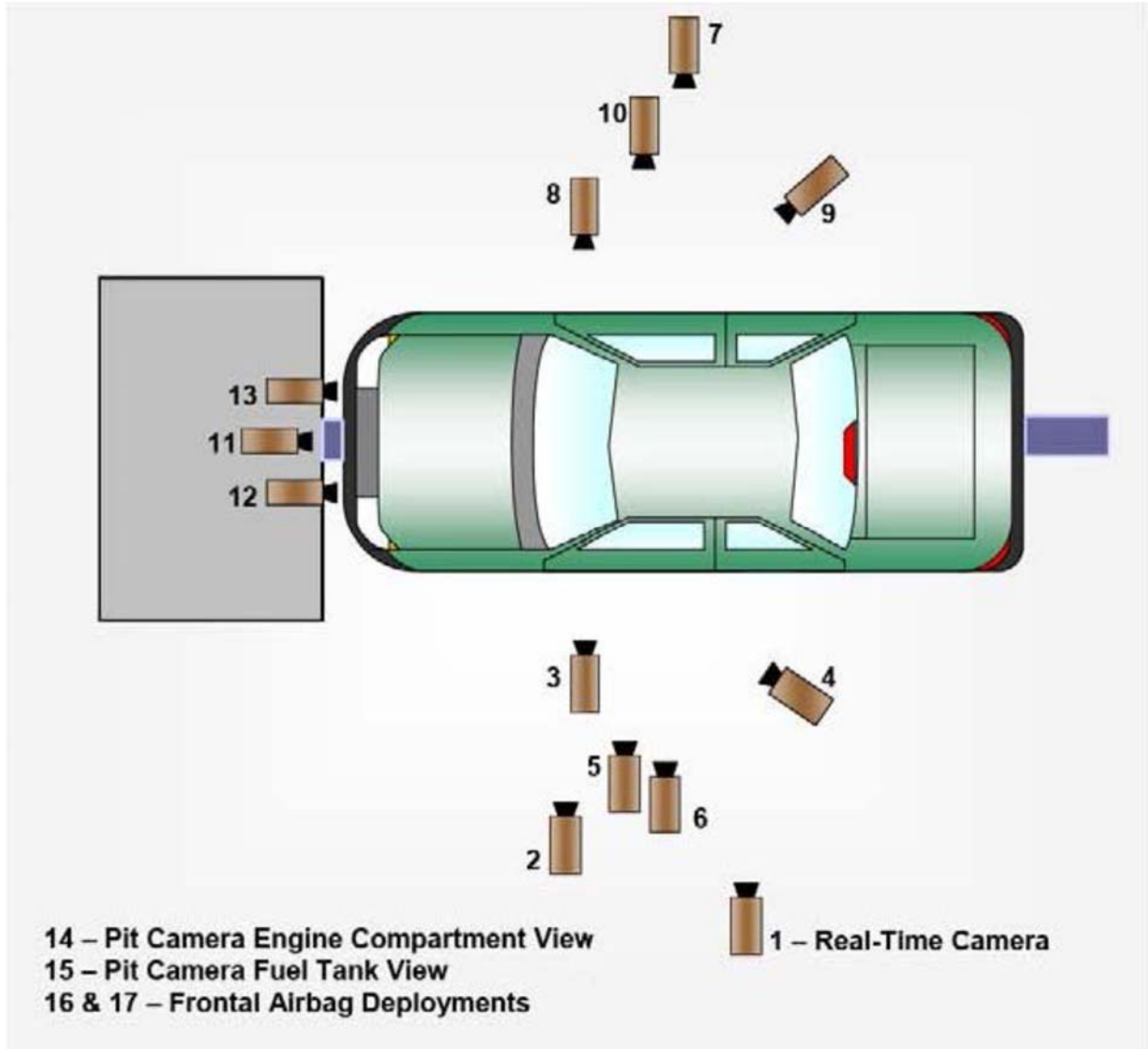

DATA SHEET NO. 6 ... (CONTINUED)

HIGH-SPEED CAMERA LOCATIONS AND DATA

Test Vehicle: 2019 Nissan Kicks S 5-Door SUV NHTSA No.: M20195206
 Test Program: 56.3 km/h Frontal Impact NCAP Test Test Date: 03/11/19

CAMERA LOCATIONS

No.	Description	Location (mm)			Lens (mm)	Speed (fps)
		X	Y	Z		
1	Real-Time Left Overall	-11412	-8150	-1484		30
2	Driver Close-Up	-2590	-7950	-1371	50	1000
3	Left Front Half	-1701	-6197	-1701	35	1000
4	Left Angle	-6696	-10308	-3211	105	1000
5	Steering Column - Top	-1966	-10412	-3688	35	1000
6	Steering Column - Bottom	-1972	-10412	-3379	35	1000
7	Right Overall	-2336	7569	-1012	20	1000
8	Passenger Close-Up	-1733	7581	-1408	50	1000
9	Right Front Half	-1600	8214	-1811	35	1000
10	Right Angle	-6217	9516	-4830	85	1000
11	Windshield	-354	0	-5749	28	1000
12	Driver Windshield	297	-366	-2460	24	1000
13	Passenger Windshield	297	366	-2460	24	1000
14	Pit Front	-756	0	1495	20	1000
15	Pit Rear	-3398	0	1495	20	1000
16	Onboard Driver Airbag (Optional)	-703	-133	-709	8	1000
17	Onboard Passenger Airbag (Optional)	-703	133	-709	8	1000
18	Real-Time Left View of Impact					
19	Real-Time Right View of Impact					

Coordinates: +X = forward impact plane
 +Y = right of monorail center
 +Z = into ground

DATA SHEET NO. 7

VEHICLE ACCELEROMETER LOCATIONS

Test Vehicle: 2019 Nissan Kicks S 5-Door SUV NHTSA No.: M20195206

Test Program: 56.3 km/h Frontal Impact NCAP Test Test Date: 03/11/19

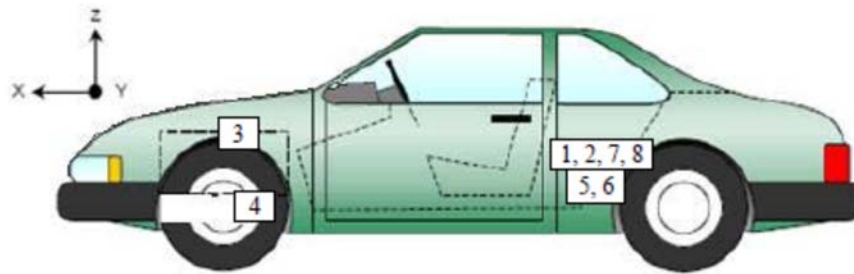
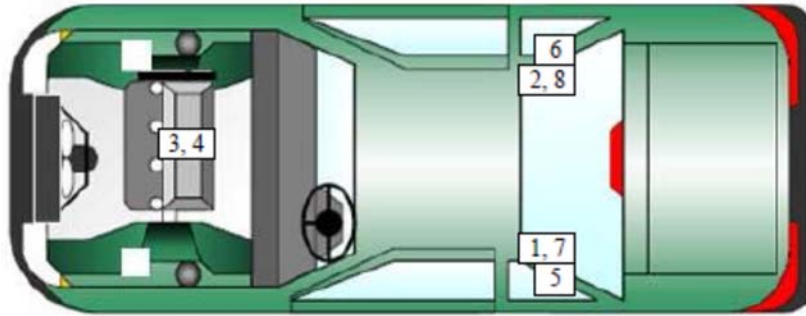

VEHICLE ACCELEROMETER PRE-TEST LOCATIONS

No.	Description	Location		
		X	Y	Z
1	Left Rear Accelerometer X-Direction	1620	-680	-400
2	Right Rear Accelerometer X-Direction	1620	680	-400
3	Engine Top X	3560	0	-770
4	Engine Bottom X	3420	220	-350
5	Left Rear Accelerometer Z-Direction	1620	-680	-400
6	Right Rear Accelerometer Z-Direction	1620	680	-400
7	Left Rear Accelerometer X-Direction Redundant	1620	-680	-400
8	Right Rear Accelerometer X-Direction Redundant	1620	680	-400

Reference Points: X – Rear Surface of Vehicle (+ forward)
 Y – Vehicle Centerline (+ to right)
 Z – Ground Plane (+ down)

DATA SHEET NO. 8

PHOTOGRAPHIC REFERENCE TARGET LOCATIONS

Test Vehicle: 2019 Nissan Kicks S 5-Door SUV NHTSA No.: M20195206

Test Program: 56.3 km/h Frontal Impact NCAP Test Test Date: 03/11/19

Item	Value
A	370
B	880
C	2006
D	610
E	1629
F	305
G	1590
H	771
I	1298
J	875
K	875
L	1250
M	773
N	1251
O	875
P	875
Q	1299

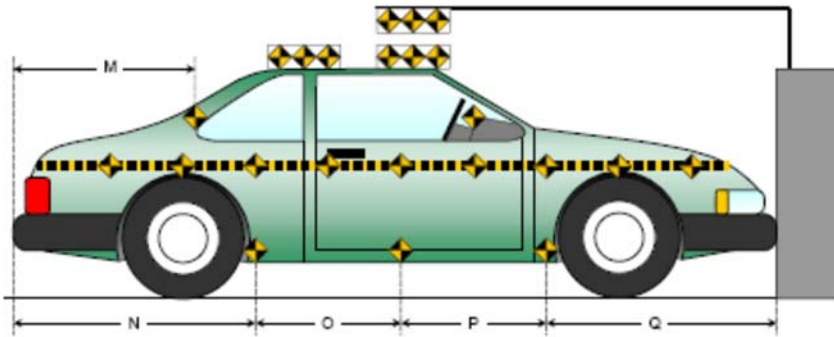
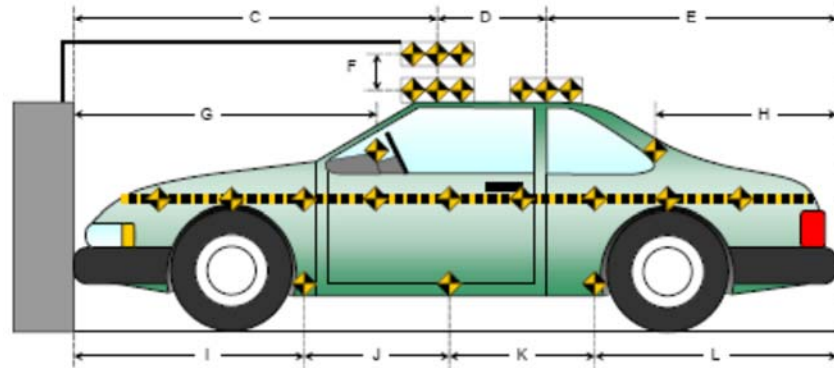
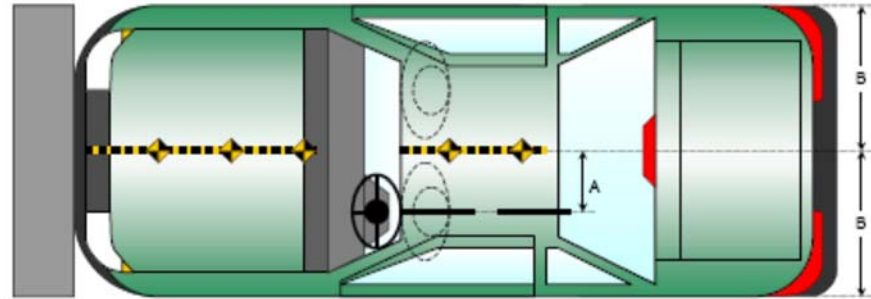

All measurements in millimeters.

DATA SHEET NO. 9

LOAD CELL LOCATIONS ON FIXED BARRIER

Test Vehicle: 2019 Nissan Kicks S 5-Door SUV NHTSA No.: M20195206

Test Program: 56.3 km/h Frontal Impact NCAP Test Test Date: 03/11/19

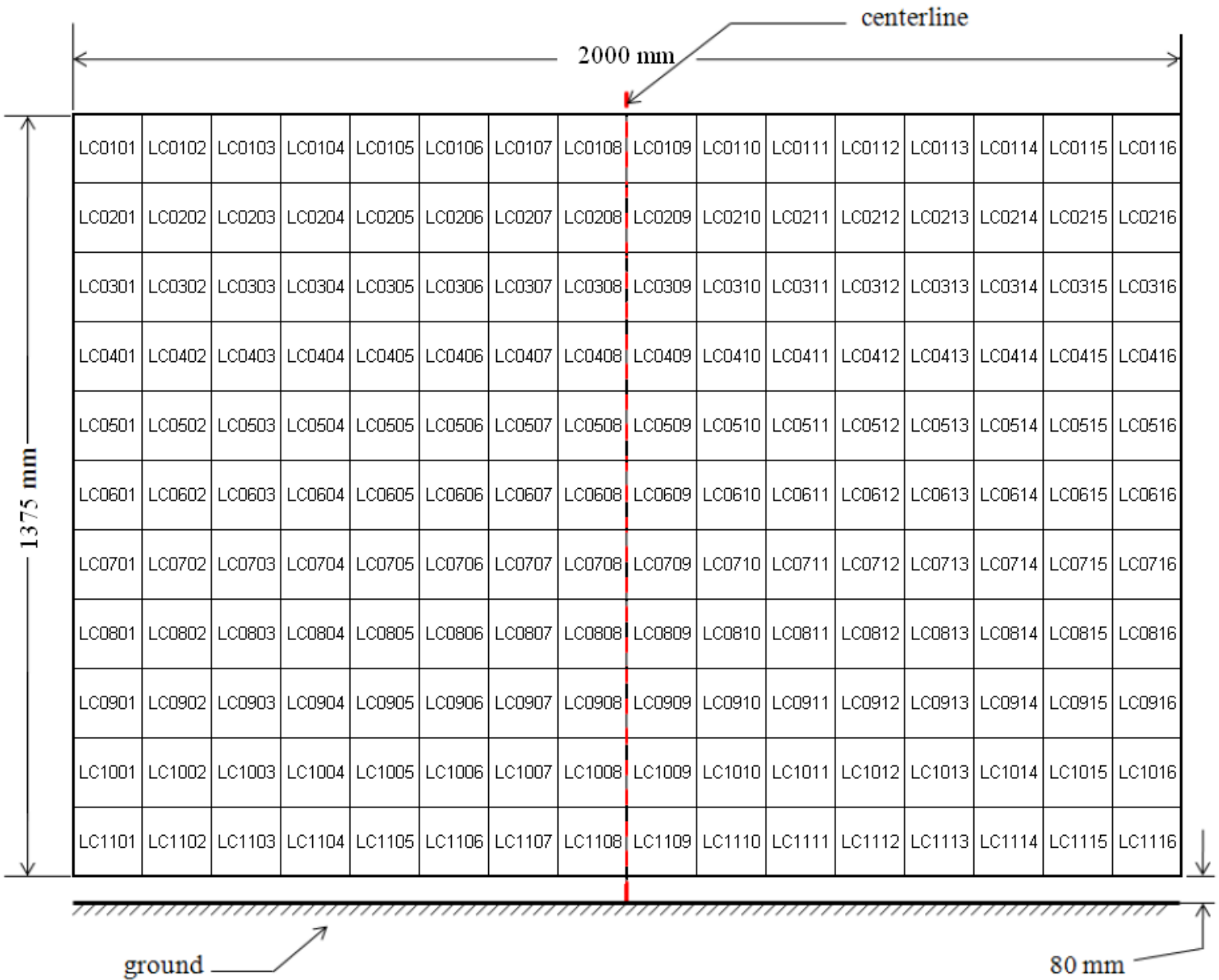

DATA SHEET NO. 10

TEST VEHICLE CAMERA AND INSTRUMENTATION SUMMARY

Test Vehicle: 2019 Nissan Kicks S 5-Door SUV NHTSA No.: M20195206

Test Program: 56.3 km/h Frontal Impact NCAP Test Test Date: 03/11/19

INSTRUMENTATION

Driver Dummy Accelerometers	47
Passenger Dummy Accelerometers	47
Vehicle Structure Accelerometers	8
Load Cell Barrier	528
Total	630

CAMERA COVERAGE

High-Speed Vehicle On Board	2
High-Speed Off Board	14
Real Time	3
Total	19

DATA SHEET NO. 11
POST-TEST OBSERVATIONS

Test Vehicle: 2019 Nissan Kicks S 5-Door SUV NHTSA No.: M20195206
 Test Program: 56.3 km/h Frontal Impact NCAP Test Test Date: 03/11/19

TEST DUMMY INFORMATION AND CONTACT

Description	Driver	Passenger
Dummy Type/Serial No.	P572E 50th Percentile Male ATD / 360	P572O 5th Percentile Female ATD / 141
Head Contact	Frontal Airbag, Headrest	Frontal Airbag, Headrest
Upper Torso Contact	Frontal Airbag	Frontal Airbag
Lower Torso Contact	None	None
Left Knee Contact	Knee Bolster	Knee Bolster
Right Knee Contact	Knee Bolster, Steering Column	Knee Bolster

DOOR OPENING AND SEAT TRACK INFORMATION

Description	Driver	Passenger
Locked / Unlocked Doors	Locked	Locked
Front Door Opening	Remained closed and latched, operational	Remained closed and latched, operational
Rear Door Opening	Remained closed and latched, operational	Remained closed and latched, operational
Seat Track Shift (mm)	0	0
Seat Back Failure	None	None
Glazing Damage	None	None

POST-TEST STRUCTURAL OBSERVATIONS

Critical Areas of Performance	Observations and Conclusions
Windshield Damage	Broken
Window Damage	None
Other Notable Effects	None

VEHICLE REBOUND FROM BARRIER

Measured Parameter	Units	Value
Left Side	mm	4590
Center	mm	4373
Right Side	mm	4367
Average	mm	4443

SUPPLEMENTAL RESTRAINT SYSTEM INFORMATION

Restraint Type	Driver		Passenger	
	Installed	Operated	Installed	Operated
Front Airbag	Yes	Yes	Yes	Yes
Side Airbag 1 (Curtain)	Yes	No	Yes	No
Side Airbag 2 (Torso/Pelvis)	Yes	No	Yes	No
Knee Airbag	Yes	Yes	No	
Seat Belt Pretensioner	Yes	Yes	Yes	Yes
Seat Belt Load Limiter	Yes	Yes	Yes	Yes

DATA SHEET NO. 12
VEHICLE PROFILE MEASUREMENTS

Test Vehicle: 2019 Nissan Kicks S 5-Door SUV NHTSA No.: M20195206
 Test Program: 56.3 km/h Frontal Impact NCAP Test Test Date: 03/11/19

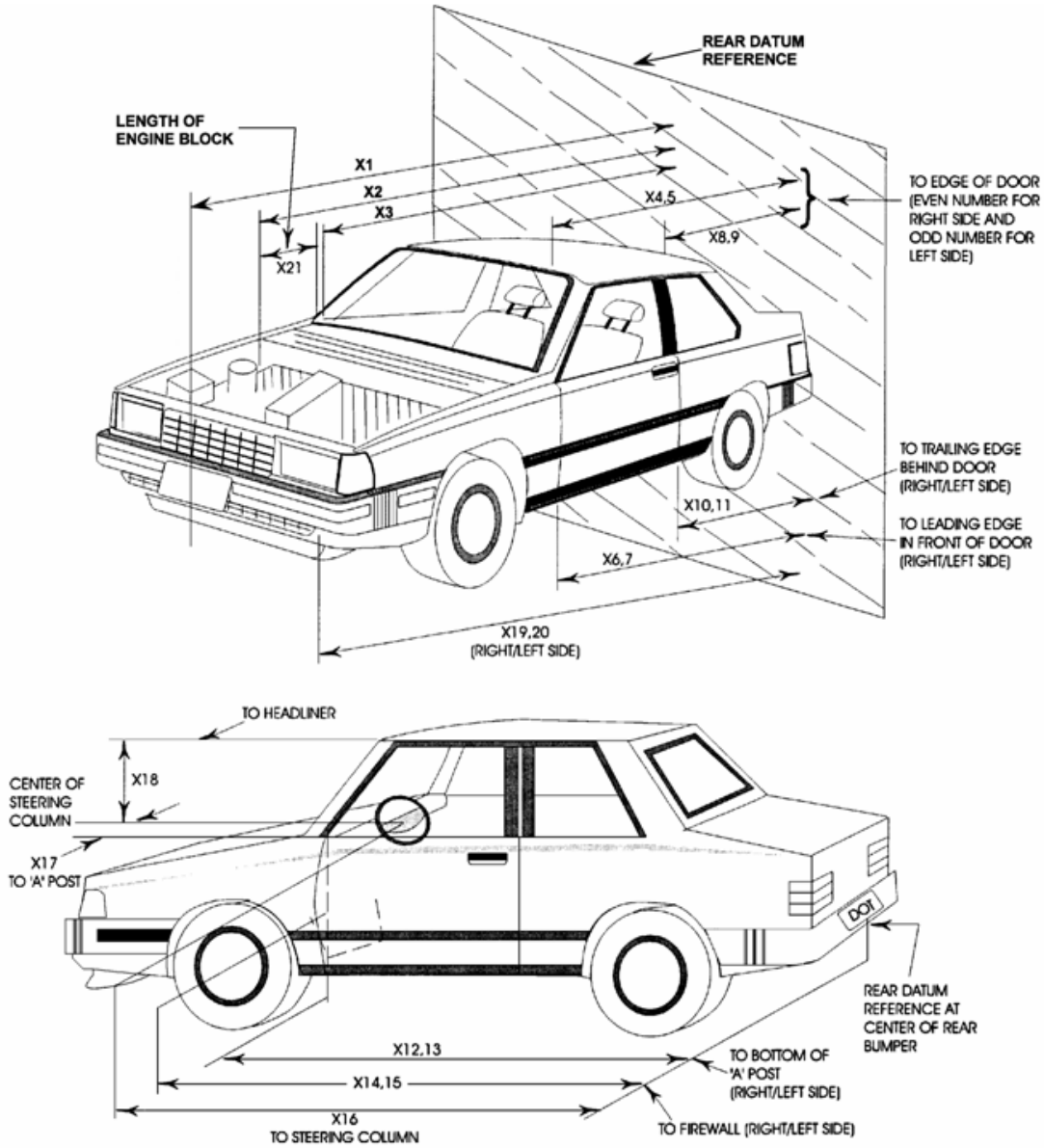

DATA SHEET NO. 12 ... (CONTINUED)

VEHICLE PROFILE MEASUREMENTS

Test Vehicle: 2019 Nissan Kicks S 5-Door SUV NHTSA No.: M20195206
 Test Program: 56.3 km/h Frontal Impact NCAP Test Test Date: 03/11/19

No.	Description	Pre-Test	Post-Test	Difference
1	Total Length of Vehicle at Centerline	4297	4224	-73
2	Rear Surface of Vehicle to Front of Engine	3831	3635	-196
3	RSOV to Firewall	3273	3294	21
4	RSOV to Upper Leading Edge of Right Door	3012	3017	5
5	RSOV to Upper Leading Edge of Left Door	3014	3011	-3
6	RSOV to Lower Leading Edge of Right Door	2978	2974	-4
7	RSOV to Lower Leading Edge of Left Door	2977	2977	0
8	RSOV to Upper Trailing Edge of Right Door	1895	1891	-4
9	RSOV to Upper Trailing Edge of Left Door	1894	1884	-10
10	RSOV to Lower Trailing Edge of Right Door	1930	1937	7
11	RSOV to Lower Trailing Edge of Left Door	1934	1935	1
12	RSOV to Bottom of A-Pillar, Right Side	2954	2952	-2
13	RSOV to Bottom of A-Pillar, Left Side	2951	2952	1
14	RSOV to Firewall, Right Side	3371	3315	-56
15	RSOV to Firewall, Left Side	3366	3360	-6
16	RSOV to Steering Column	2711	2554	-157
17	Center of Steering Column to A-Pillar	430	440	10
18	Center of Steering Column to Headliner	510	460	-50
19	RSOV to Right Side of Front Bumper	3660	3645	-15
20	RSOV to Left Side of Front Bumper	3661	3657	-4
21	Length of Engine Block	590	590	0
RD	RSOV to Right Side of Dash Panel	2720	2716	-4
CD	RSOV to Center of Dash Panel	2660	2662	2
LD	RSOV to Left Side of Dash Panel	2714	2710	-4

All measurements in millimeters.

DATA SHEET NO. 13

ACCIDENT INVESTIGATION DIVISION DATA

Test Vehicle: 2019 Nissan Kicks S 5-Door SUV NHTSA No.: M20195206
 Test Program: 56.3 km/h Frontal Impact NCAP Test Test Date: 03/11/19

VEHICLE INFORMATION

VIN: 3N1CP5CU9KL481704 Wheelbase (mm): 2618
 Vehicle Size Category: Passenger Car Test Weight (kg): 1370.5

ACCELEROMETER DATA

Accelerometer Locations: Left Rear Crossmember
 Cal. Procedure/Interval: Vibration Test / 6 months
 Integration Algorithm: NHTSA Standard
 Impact Velocity (km/h): 56.48
 Velocity Change (km/h): 69.4
 Time of Separation (msec): 65.1

Linearity: Good

CRUSH PROFILE

Collision Deformation Classification: 12FDEW2
 Midpoint of Damage: Vehicle Centerline
 Damage Region Length (mm): 1390
 Impact Mode: Full Frontal

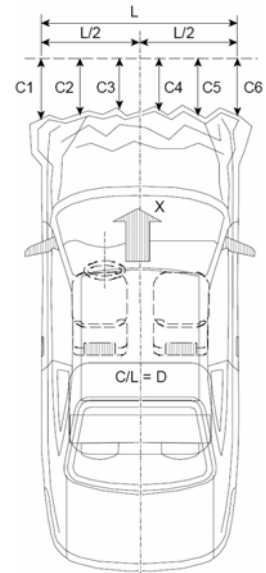

No.	Measurement Description	Units	Pre-Test	Post-Test	Difference
C1	Crush Zone 1 at Left Side	mm	208	520	312
C2	Crush Zone 2 at Left Side	mm	74	448	374
C3	Crush Zone 3 at Left Side	mm	23	448	425
C4	Crush Zone 4 at Right Side	mm	23	458	435
C5	Crush Zone 5 at Right Side	mm	74	474	400
C6	Crush Zone 6 at Right Side	mm	208	537	329
L	C1 to C6	mm	1390		

DATA SHEET NO. 14

VEHICLE INTRUSION MEASUREMENTS

Test Vehicle: 2019 Nissan Kicks S 5-Door SUV NHTSA No.: M20195206

Test Program: 56.3 km/h Frontal Impact NCAP Test Test Date: 03/11/19

DOOR OPENING WIDTH

Item	Description	Units	Pre-Test	Post-Test	Difference
A	Left Side Upper	mm	971	973	-2
B	Left Side Lower	mm	892	877	15
D	Right Side Upper	mm	980	972	8
E	Right Side Lower	mm	873	856	17

WHEELBASE MEASUREMENTS

Item	Description	Units	Pre-Test	Post-Test	Difference
C	Left Side Wheelbase	mm	2618	2590	28
F	Right Side Wheelbase	mm	2618	2583	35

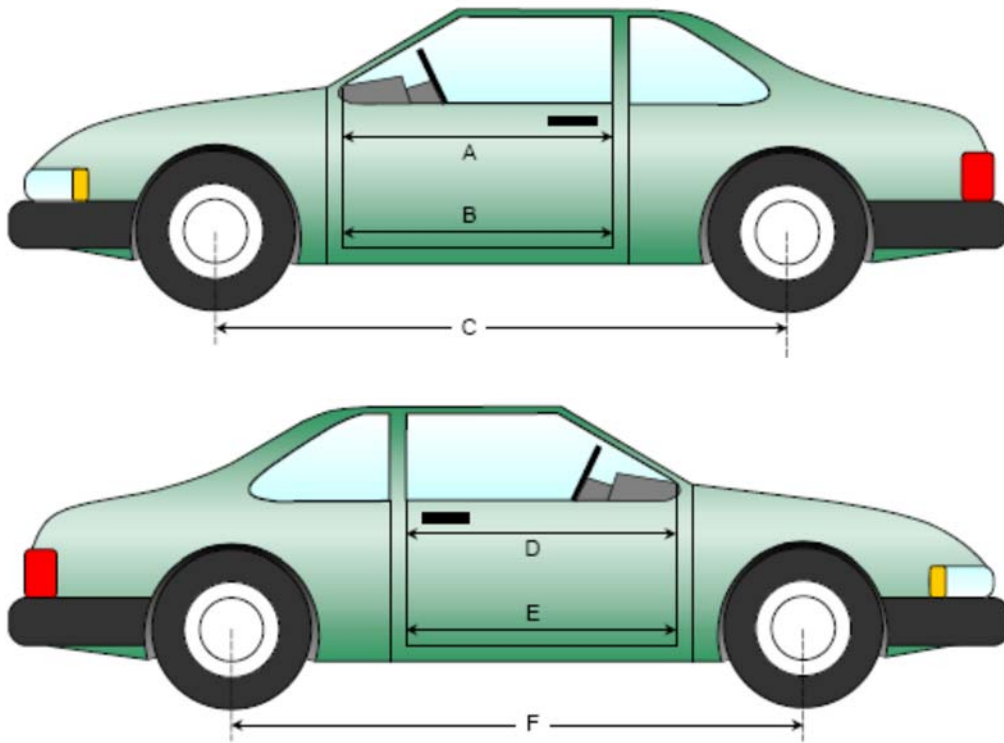

DATA SHEET NO. 14 ... (CONTINUED)
VEHICLE INTRUSION MEASUREMENTS

Test Vehicle: 2019 Nissan Kicks S 5-Door SUV NHTSA No.: M20195206
 Test Program: 56.3 km/h Frontal Impact NCAP Test Test Date: 03/11/19

DRIVER COMPARTMENT INTRUSION

Item	Description	Units	Pre-Test	Post-Test	Difference
AB	Door Opening (Inside Window Jam)	mm	910	900	10
CX	Left Knee Bolster to X	mm	340	335	5
DX	Right Knee Bolster to X	mm	340	330	10
EX	Brake Pedal to X	mm	520	510	10
FX	Foot Rest to X	mm	525	520	5
GX	Center of Steering Wheel Hub to X	mm	40	130	-90

X = Front of Seat Track (Stationary)

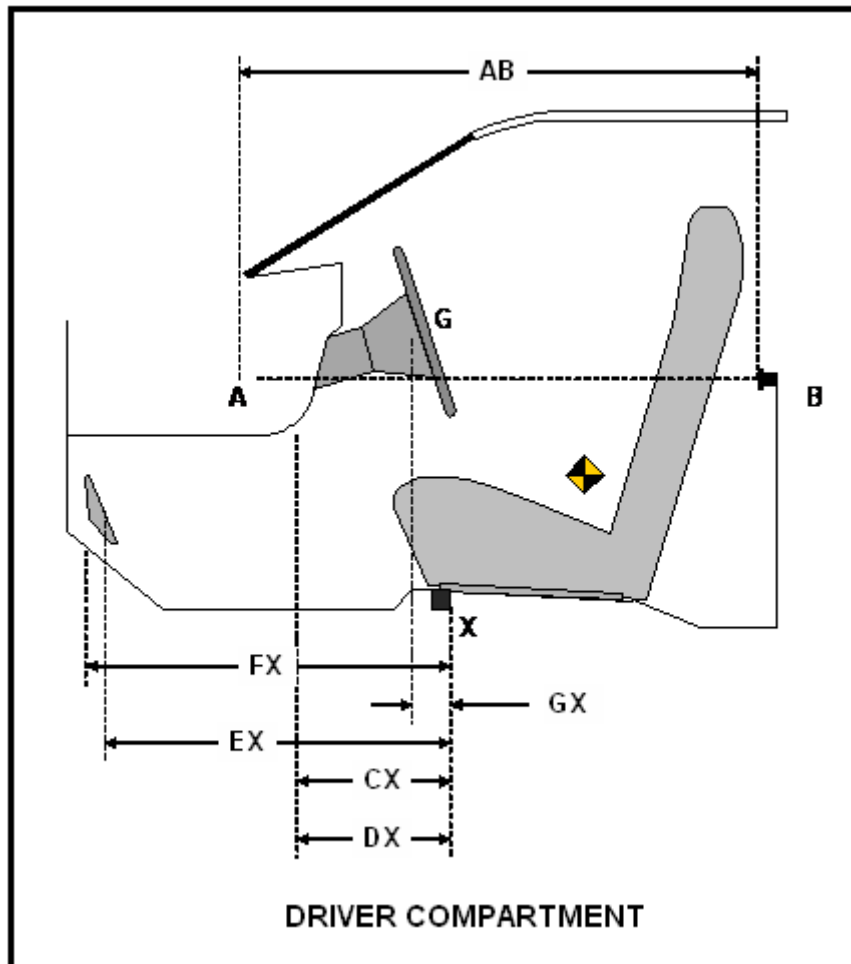

DATA SHEET NO. 15

SUMMARY OF FMVSS 212, 219 (PARTIAL), AND 301 DATA

Test Vehicle: 2019 Nissan Kicks S 5-Door SUV NHTSA No.: M20195206
 Test Program: 56.3 km/h Frontal Impact NCAP Test Test Date: 03/11/19

Windshield Mounting Details: Windshield glass is secured to the vehicle frame with rubber molding and rubber cement.

The standard requires that the post-test retention measurement be a minimum of 75% of the pre-test total periphery measurement for vehicles not equipped with occupant passive restraints and 50% for each side of the windshield for vehicles which are equipped with occupant passive restraints.

Temperature of windshield molding during test: 21.3° C

WINDSHIELD PERIPHERY MEASUREMENTS

Measurement	Pre-Test (mm)	Post-Test (mm)	% Retention
Left Side	2198	2198	100.0%
Right Side	2198	2198	100.0%
Total	4396	4396	100.0%

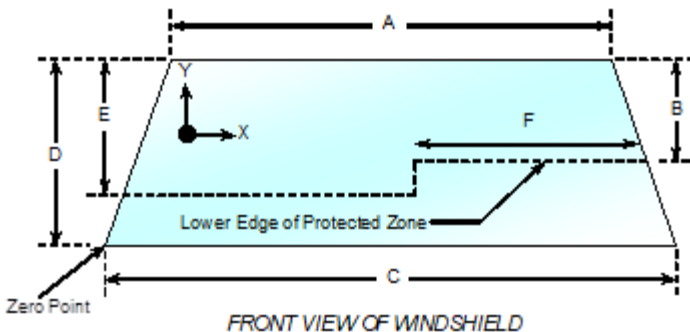

Item	Units	Value
A	mm	1150
B	mm	590
C	mm	1380
D	mm	933
E	mm	480
F	mm	529

AREAS OF PROTECTED ZONE FAILURES

A. Provide Coordinates of the area that the protected zone was penetrated more than 0.25 inches by a vehicle component other than one that is normally in contact with the windshield.

X	Y

B. Provide coordinates of the area beneath the protected zone that the inner surface of the windshield was penetrated by a vehicle component.

X	Y

DATA SHEET NO. 15 ... (CONTINUED)

SUMMARY OF FMVSS 212, 219 (PARTIAL), AND 301 DATA

Test Vehicle: 2019 Nissan Kicks S 5-Door SUV NHTSA No.: M20195206

Test Program: 56.3 km/h Frontal Impact NCAP Test Test Date: 03/11/19

FMVSS 301 FUEL SYSTEM INTEGRITY POST IMPACT DATA

Temperature at Time of Impact: 13.9° C Test Time: 1:04 PM

Stoddard Solvent Spillage Measurements

- A. From impact until vehicle motion ceases: 0 oz.
(Maximum allowable = 1 oz.)
- B. For the 5 minute period after motion ceases: 0 oz.
(Maximum allowable = 5 oz.)
- C. For the following 25 minutes: 0 oz.
(Maximum allowable = 1 oz./minute)
- D. Spillage: There was no Stoddard solvent spillage.

DATA SHEET NO. 16

FMVSS 301 STATIC ROLLOVER RESULTS

Test Vehicle: 2019 Nissan Kicks S 5-Door SUV NHTSA No.: M20195206
 Test Program: 56.3 km/h Frontal Impact NCAP Test Test Date: 03/11/19

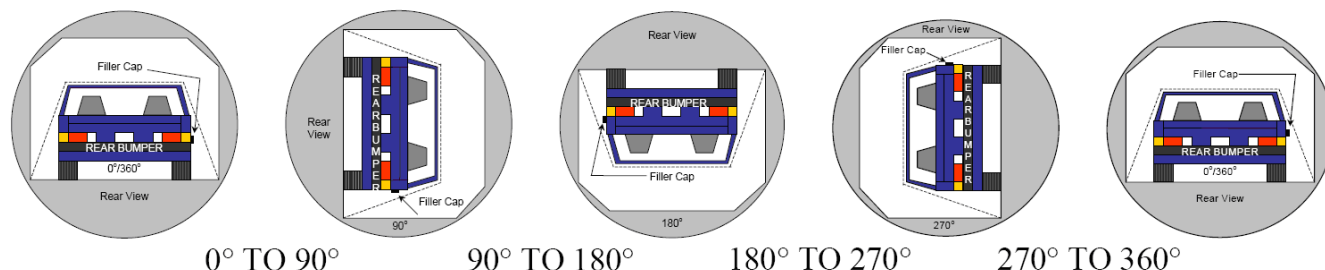

1. The specified fixture rollover rate for each 90° of rotation is 60 to 180 seconds.
2. The position hold time at each position is 300 seconds (minimum).
3. Details of Stoddard solvent spillage: There was no Stoddard solvent spillage.

SOLVENT COLLECTION TIME TABLE IN SECONDS

Test Phase	Rotation Time	Hold Time	Total Time
0° To 90°	83	300	383
90° To 180°	82	300	382
180° To 270°	78	300	378
270° To 360°	82	300	382

FMVSS 301 SPILLAGE TABLE

Test Phase	First 5 Minutes	Sixth Minute	Seventh Minute	Eighth Minute
0° To 90°	0			
90° To 180°	0			
180° To 270°	0			
270° To 360°	0			

SOLVENT SPILLAGE LOCATION TABLE

Test Phase	Spillage Location
0° To 90°	
90° To 180°	
180° To 270°	
270° To 360°	

DATA SHEET NO. 17

DUMMY / VEHICLE TEMPERATURE STABILIZATION CHART

Test Vehicle: 2019 Nissan Kicks S 5-Door SUV NHTSA No.: M20195206

Test Program: 56.3 km/h Frontal Impact NCAP Test Test Date: 03/11/19

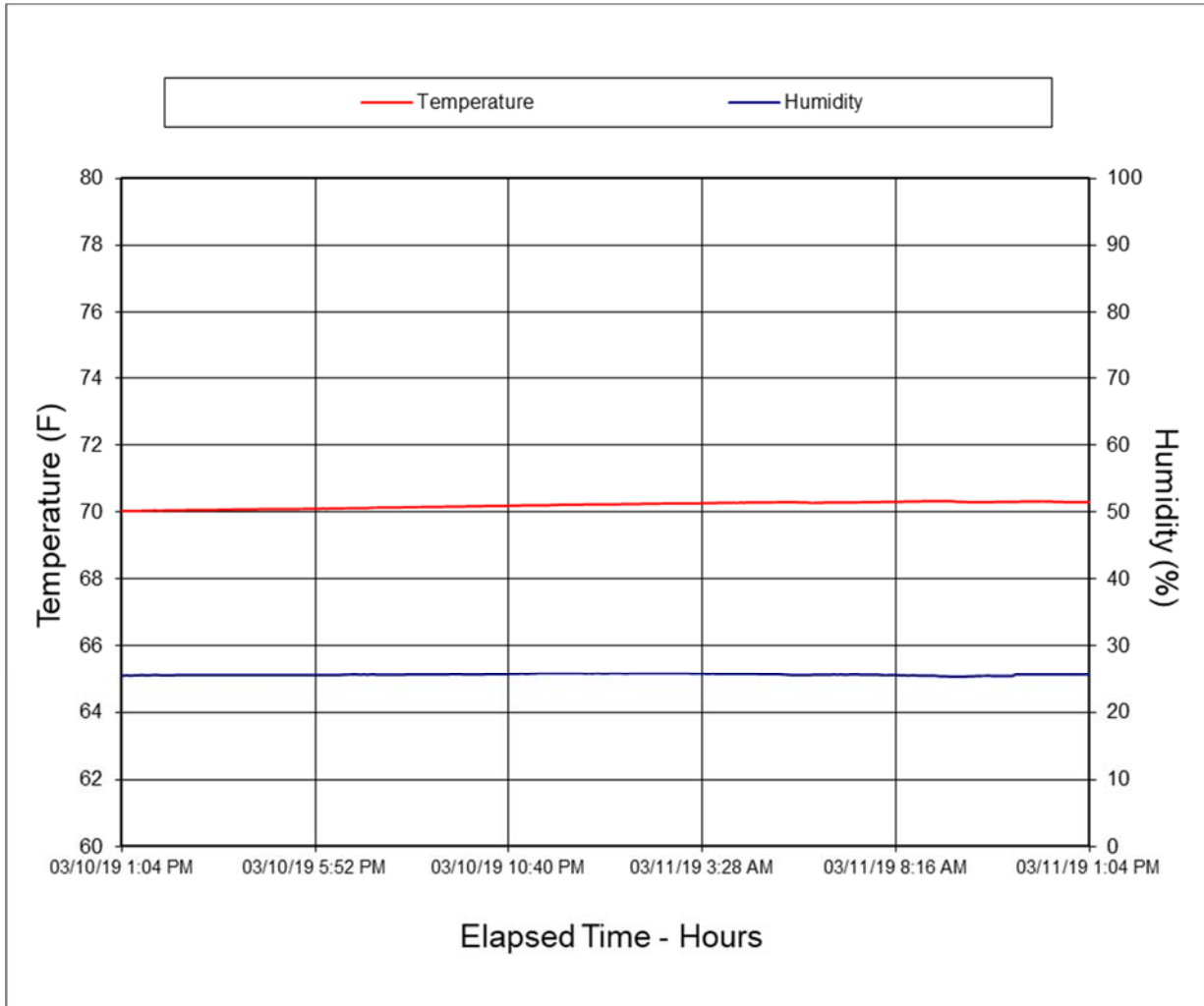

**APPENDIX A
PHOTOGRAPHS**

TABLE OF PHOTOGRAPHS

Figure		Page
1	Load Cell Location	A-1
2	Pre-Test Load Cell Wall	A-1
3	Post-Test Load Cell Wall	A-2
4	Manufacturer's Label	A-2
5	Tire Placard	A-3
6	2019 Nissan Kicks S Frontal as Delivered	A-3
7	Left Rear $\frac{3}{4}$ View, as Received	A-4
8	Pre-Test Front View of Test Vehicle	A-4
9	Post-Test Front View of Test Vehicle	A-5
10	Pre-Test Left View of Test Vehicle	A-5
11	Post-Test Left View of Test Vehicle	A-6
12	Pre-Test Right View of Test Vehicle	A-6
13	Post-Test Right View of Test Vehicle	A-7
14	Pre-Test Right Front $\frac{3}{4}$ View	A-7
15	Post-Test Right Front $\frac{3}{4}$ View	A-8
16	Pre-Test Left Rear $\frac{3}{4}$ View	A-8
17	Post-Test Left Rear $\frac{3}{4}$ View	A-9
18	Pre-Test Windshield View	A-9
19	Post-Test Windshield View	A-10
20	Pre-Test Engine Compartment View	A-10
21	Post-Test Engine Compartment View	A-11
22	Pre-Test Fuel Filler Cap View	A-11
23	Post-Test Fuel Filler Cap View	A-12
24	Pre-Test Front Underbody View	A-12
25	Post-Test Front Underbody View	A-13
26	Pre-Test Rear Underbody View	A-13
27	Post-Test Rear Underbody View	A-14
28	Pre-Test Dummy Cable Routing	A-14
29	Post-Test Dummy Cable Routing	A-15
30	Pre-Test Driver Dummy Front View	A-15
31	Post-Test Driver Dummy Front View	A-16
32	Pre-Test Driver Dummy Window View	A-16
33	Post-Test Driver Dummy Window View	A-17
34	Pre-Test Driver Dummy and Vehicle Interior View	A-17
35	Post-Test Driver Dummy and Vehicle Interior View	A-18
36	Pre-Test Driver's Seat Fore-Aft Markings	A-18

TABLE OF PHOTOGRAPHS ... (CONTINUED)

Figure		Page
37	Post-Test Driver's Seat Fore-Aft Markings	A-19
38	Pre-Test View of Belt Anchorage for Driver Dummy	A-19
39	Post-Test View of Belt Anchorage for Driver Dummy	A-20
40	Pre-Test Driver Dummy Feet	A-20
41	Post-Test Driver Dummy Feet	A-21
42	Pre-Test Driver's Side Knee Bolster	A-21
43	Post-Test Driver's Side Knee Bolster	A-22
44	Pre-Test Driver's Side Floorpan	A-22
45	Post-Test Driver's Side Floorpan	A-23
46	Post-Test Driver Dummy Face	A-23
47	Post-Test Driver Dummy Contact with Airbag	A-24
48	Post-Test Driver Dummy Contact with Headrest	A-24
48a	Post-Test Driver Dummy Contact with Knee Airbag	A-25
49	Pre-Test View of the Steering Wheel	A-25
50	Post-Test View of the Steering Wheel	A-26
51	Pre-Test Passenger Dummy Front View	A-26
52	Post-Test Passenger Dummy Front View	A-27
53	Pre-Test Passenger Dummy Window View	A-27
54	Post-Test Passenger Dummy Window View	A-28
55	Pre-Test Passenger Dummy and Vehicle Interior View	A-28
56	Post-Test Passenger Dummy and Vehicle Interior View	A-29
57	Pre-Test Passenger's Seat Fore-Aft Markings	A-29
58	Post-Test Passenger's Seat Fore-Aft Markings	A-30
59	Pre-Test View of Belt Anchorage for Passenger Dummy	A-30
60	Post-Test View of Belt Anchorage for Passenger Dummy	A-31
61	Pre-Test Passenger Dummy Feet	A-31
62	Post-Test Passenger Dummy Feet	A-32
63	Pre-Test Passenger's Side Knee Bolster	A-32
64	Post-Test Passenger's Side Knee Bolster	A-33
65	Pre-Test Passenger's Side Floorpan	A-33
66	Post-Test Passenger's Side Floorpan	A-34
67	Post-Test Passenger Dummy Face	A-34
68	Post-Test Passenger Dummy Contact with Airbag	A-35
69	Post-Test Passenger Dummy Contact with Headrest	A-35
69a	Post-Test Passenger Dummy Contact with Knee Airbag	A-36
70	Photograph of Ballast Installed in Vehicle	A-36

TABLE OF PHOTOGRAPHS ... (CONTINUED)

<u>Figure</u>		<u>Page</u>
71	Post-Test Stoddard Solvent Spillage Location View	A-37
72	Post-Test Speed Trap Read-Out	A-37
73	Vehicle at 0° on Static Rollover Device	A-38
74	Vehicle at 90° on Static Rollover Device	A-38
75	Vehicle at 180° on Static Rollover Device	A-39
76	Vehicle at 270° on Static Rollover Device	A-39
77	Vehicle at 360° on Static Rollover Device	A-40
78	2019 Nissan Kicks S Frontal Impact Event	A-40
79	Monronev Label Photograph	A-41



FIGURE 1. Load Cell Location

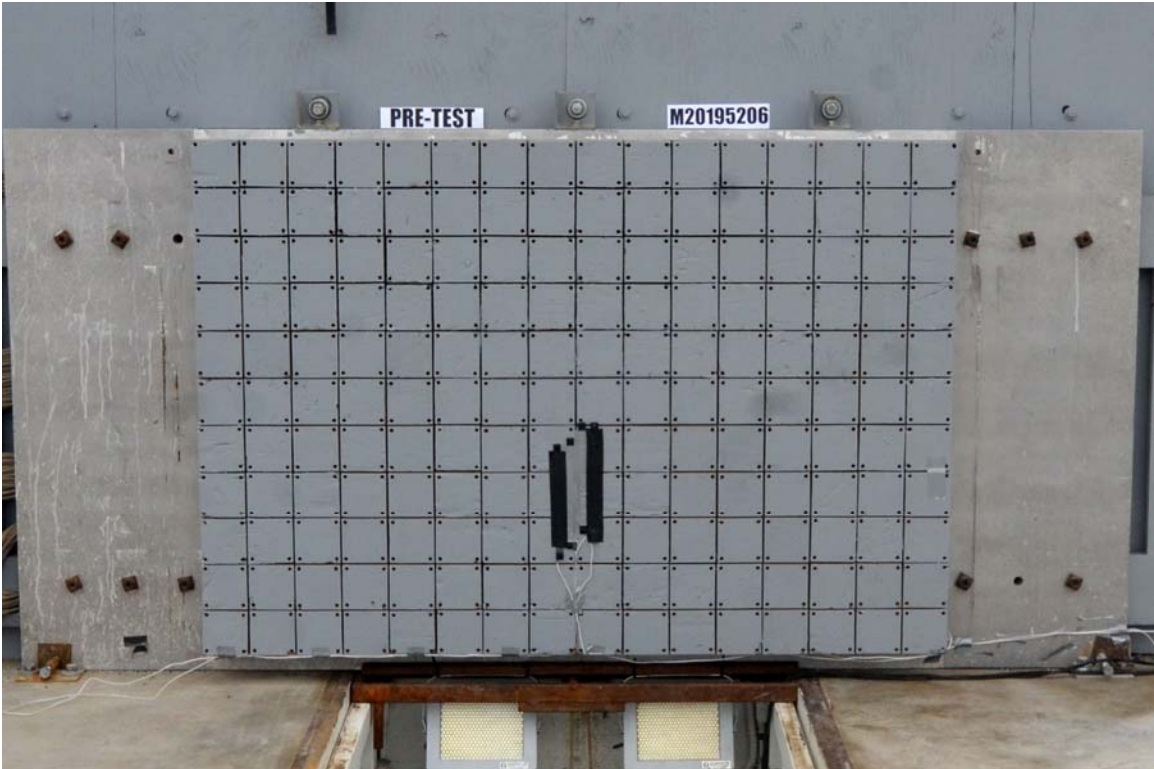

FIGURE 2. Pre-Test Load Cell Wall

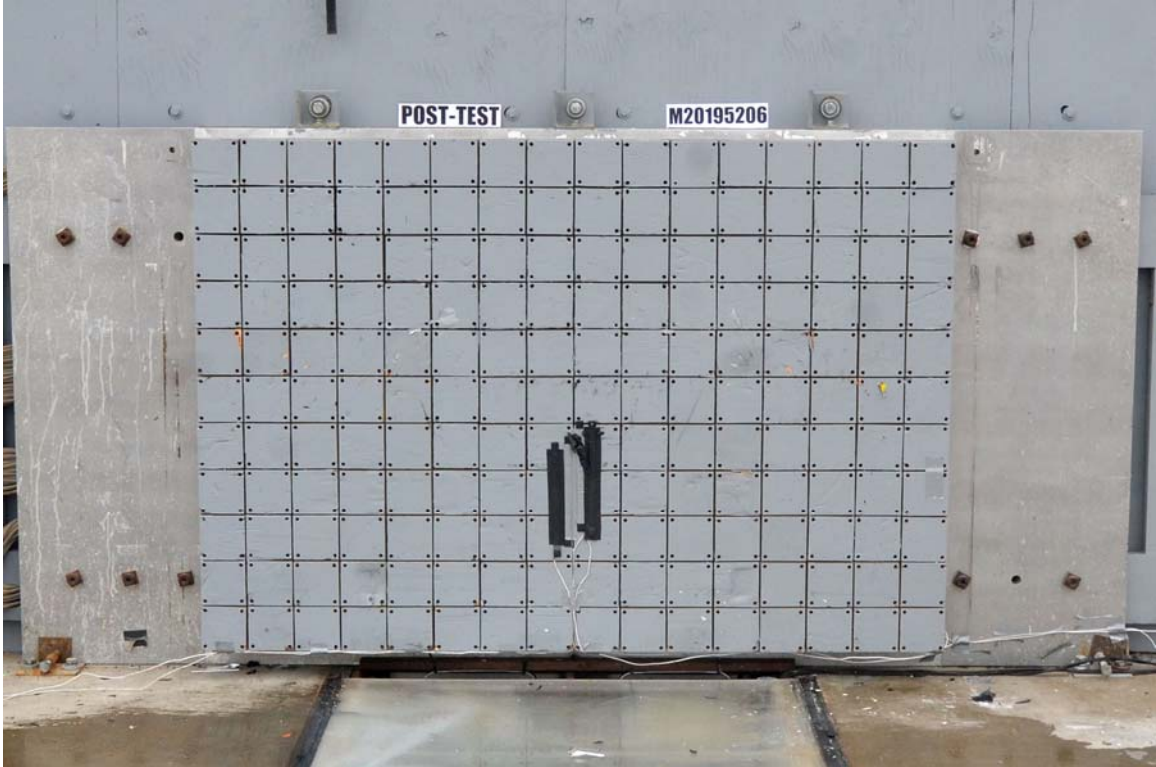

FIGURE 3. Post-Test Load Cell Wall

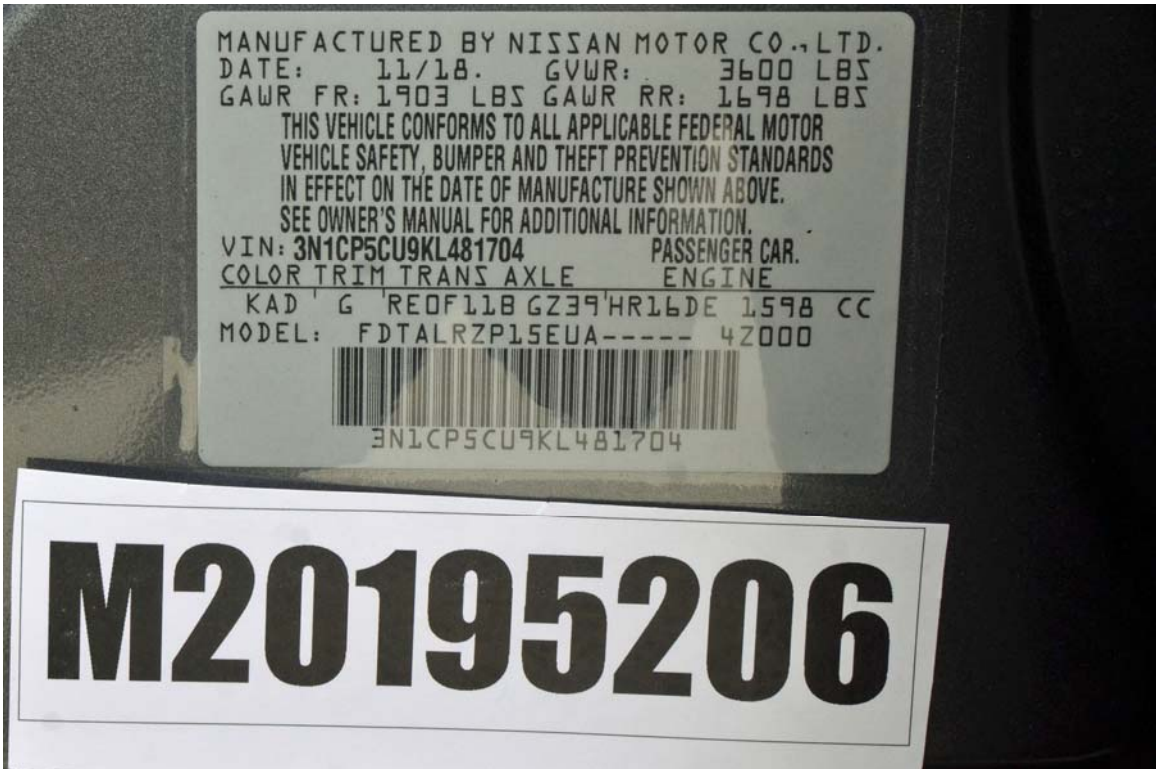

FIGURE 4. Manufacturer's Label

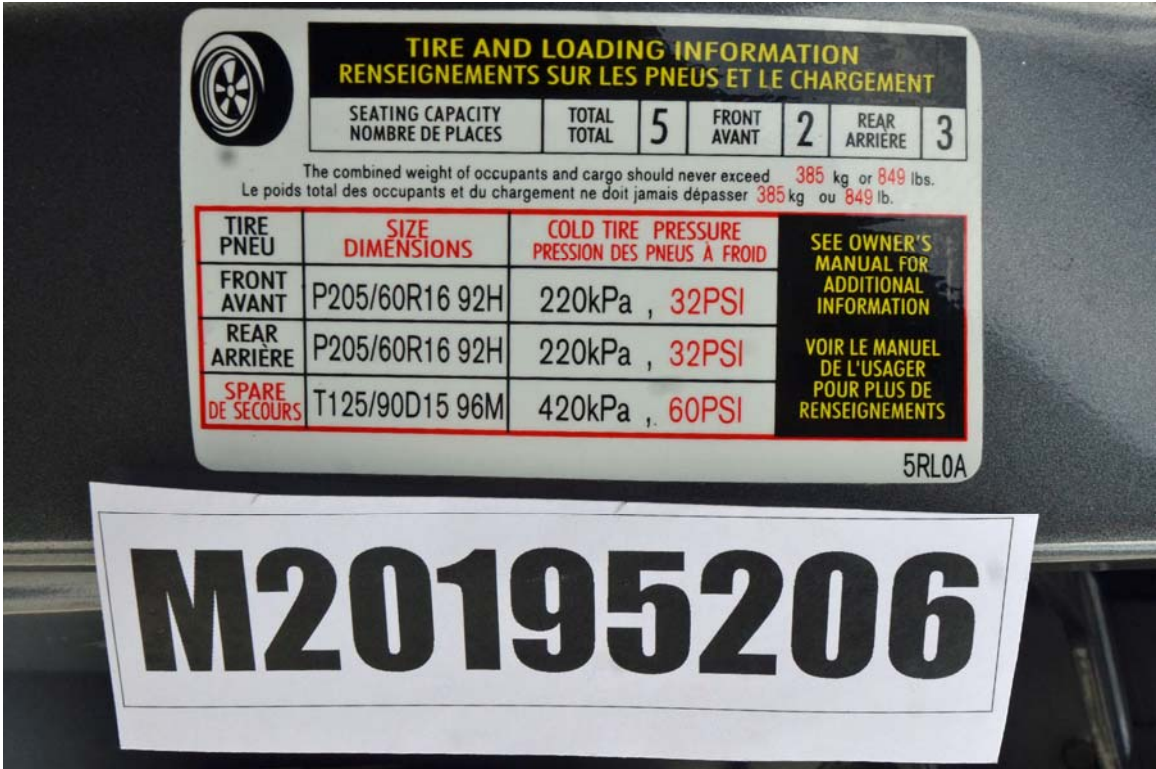

FIGURE 5. Tire Placard



FIGURE 6. 2019 Nissan Kicks S Frontal as Delivered



FIGURE 7. Left Rear $\frac{3}{4}$ View, as Received



FIGURE 8. Pre-Test Front View of Test Vehicle



FIGURE 9. Post-Test Front View of Test Vehicle



FIGURE 10. Pre-Test Left View of Test Vehicle



FIGURE 11. Post-Test Left View of Test Vehicle



FIGURE 12. Pre-Test Right View of Test Vehicle



FIGURE 13. Post-Test Right View of Test Vehicle



FIGURE 14. Pre-Test Right Front 3/4 View



FIGURE 15. Post-Test Right Front $\frac{3}{4}$ View



FIGURE 16. Pre-Test Left Rear $\frac{3}{4}$ View



FIGURE 17. Post-Test Left Rear $\frac{3}{4}$ View



FIGURE 18. Pre-Test Windshield View



FIGURE 19. Post-Test Windshield View



FIGURE 20. Pre-Test Engine Compartment View



FIGURE 21. Post-Test Engine Compartment View



FIGURE 22. Pre-Test Fuel Filler Cap View



FIGURE 23. Post-Test Fuel Filler Cap View

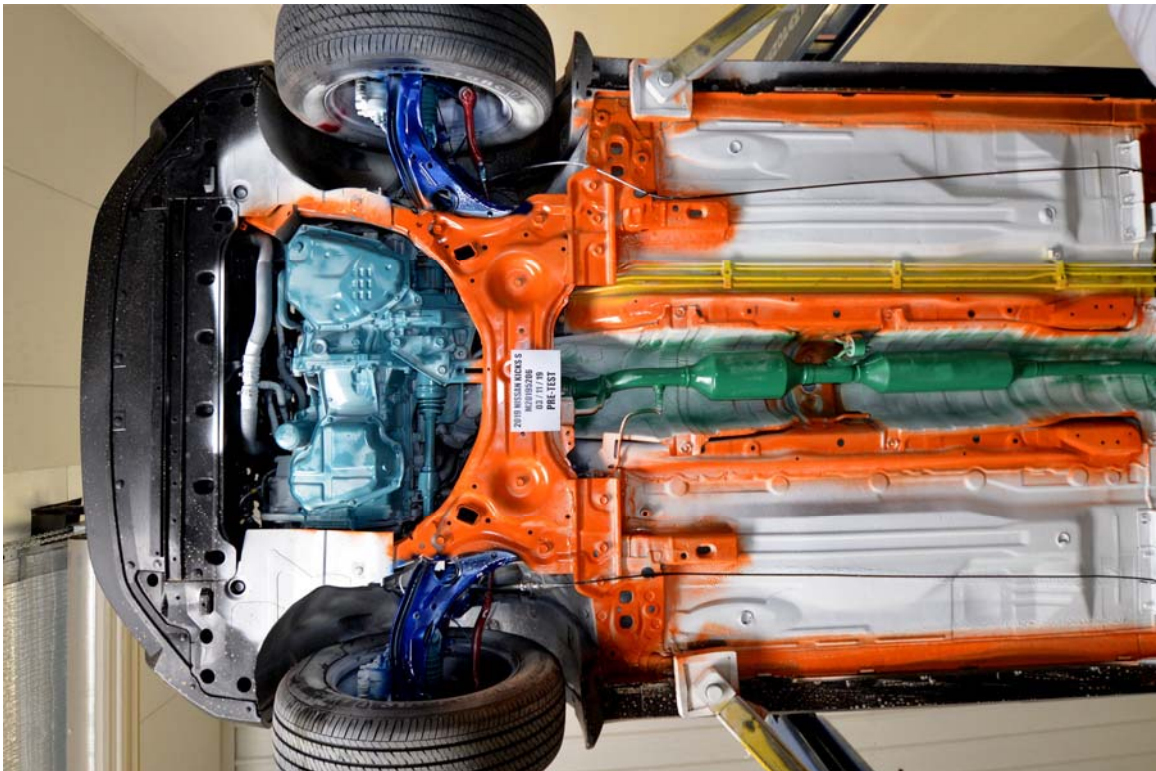

FIGURE 24. Pre-Test Front Underbody View



FIGURE 25. Post-Test Front Underbody View

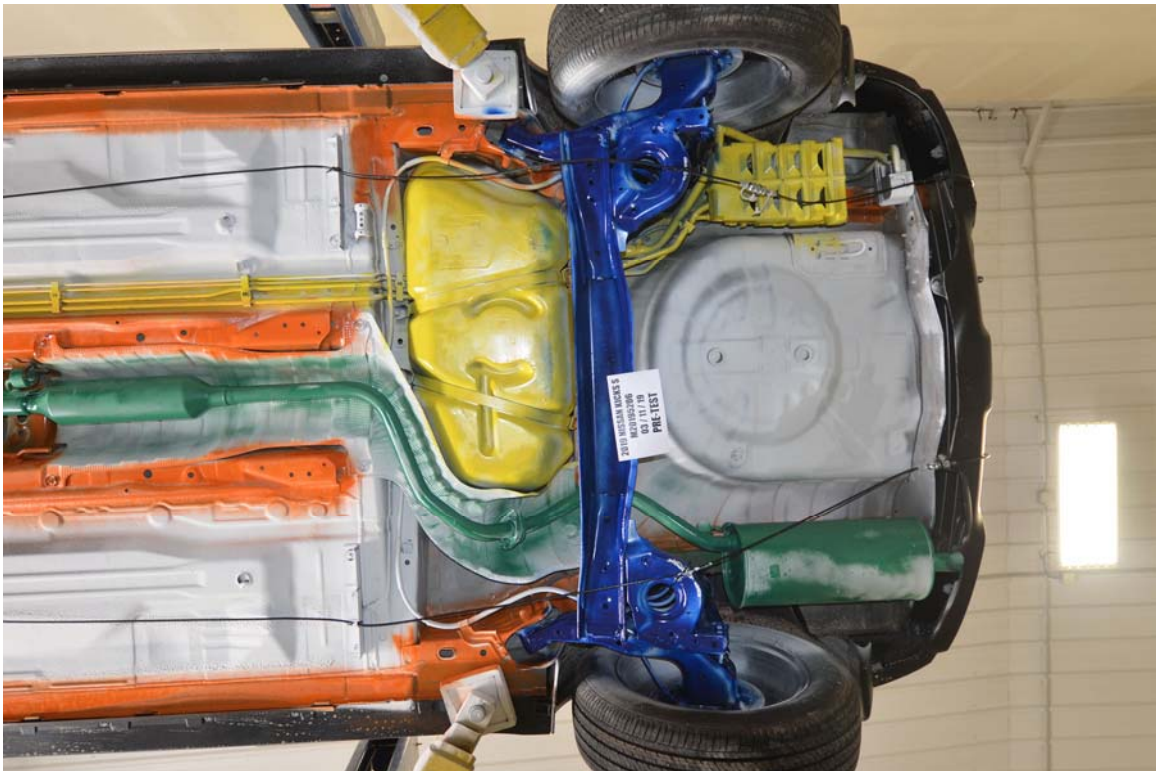

FIGURE 26. Pre-Test Rear Underbody View



FIGURE 27. Post-Test Rear Underbody View

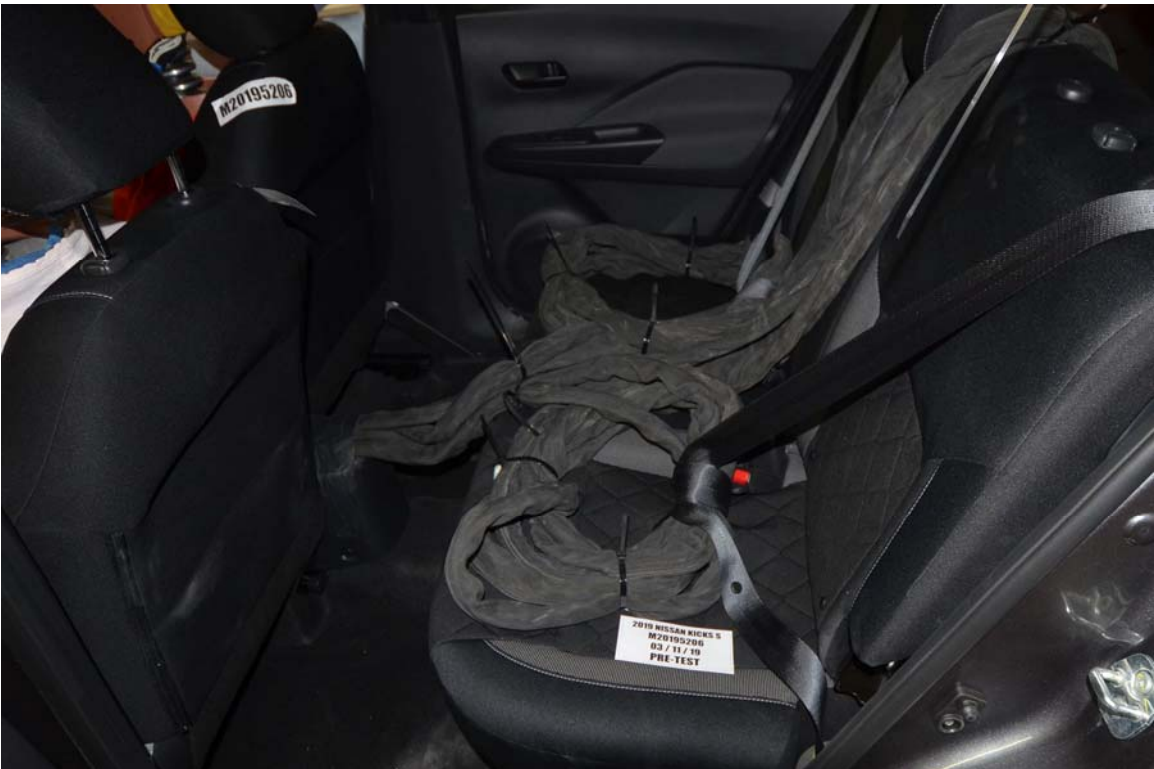

FIGURE 28. Pre-Test Dummy Cable Routing



FIGURE 29. Post-Test Dummy Cable Routing



FIGURE 30. Pre-Test Driver Dummy Front View



FIGURE 31. Post-Test Driver Dummy Front View



FIGURE 32. Pre-Test Driver Dummy Window View



FIGURE 33. Post-Test Driver Dummy Window View



FIGURE 34. Pre-Test Driver Dummy and Vehicle Interior View



FIGURE 35. Post-Test Driver Dummy and Vehicle Interior View



FIGURE 36. Pre-Test Driver's Seat Fore-Aft Markings



FIGURE 37. Post-Test Driver's Seat Fore-Aft Markings



FIGURE 38. Pre-Test View of Belt Anchorage for Driver Dummy



FIGURE 39. Post-Test View of Belt Anchorage for Driver Dummy



FIGURE 40. Pre-Test Driver Dummy Feet



FIGURE 41. Post-Test Driver Dummy Feet



FIGURE 42. Pre-Test Driver's Side Knee Bolster



FIGURE 43. Post-Test Driver's Side Knee Bolster



FIGURE 44. Pre-Test Driver's Side Floorpan



FIGURE 45. Post-Test Driver's Side Floorpan

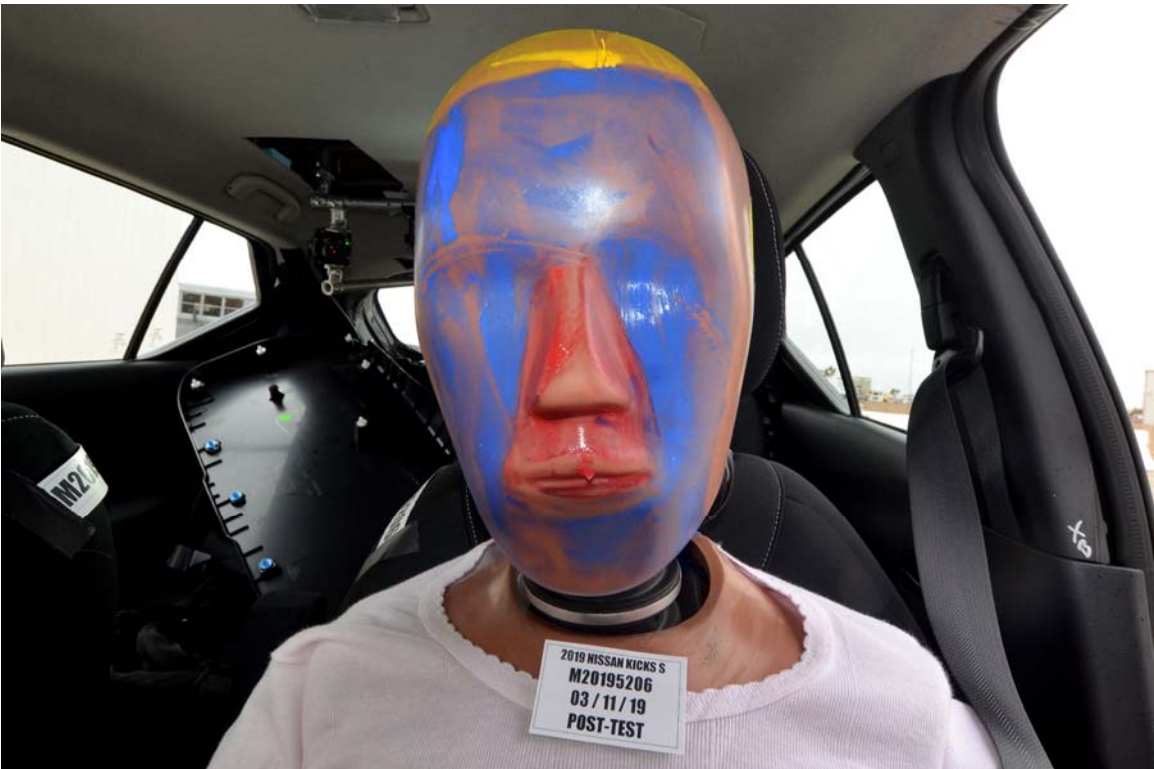

FIGURE 46. Post-Test Driver Dummy Face



FIGURE 47. Post-Test Driver Dummy Contact with Airbag



FIGURE 48. Post-Test Driver Dummy Contact with Headrest

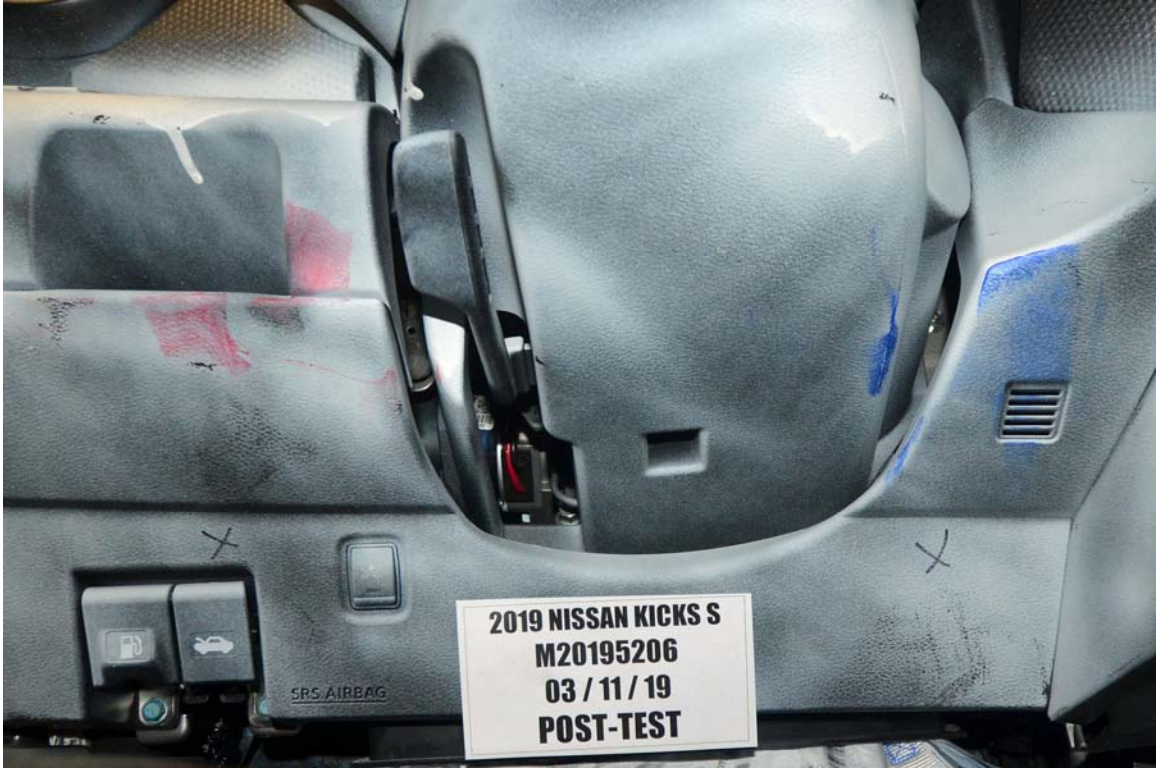

FIGURE 48a. Post-Test Driver Dummy Contact with Knee Bolster

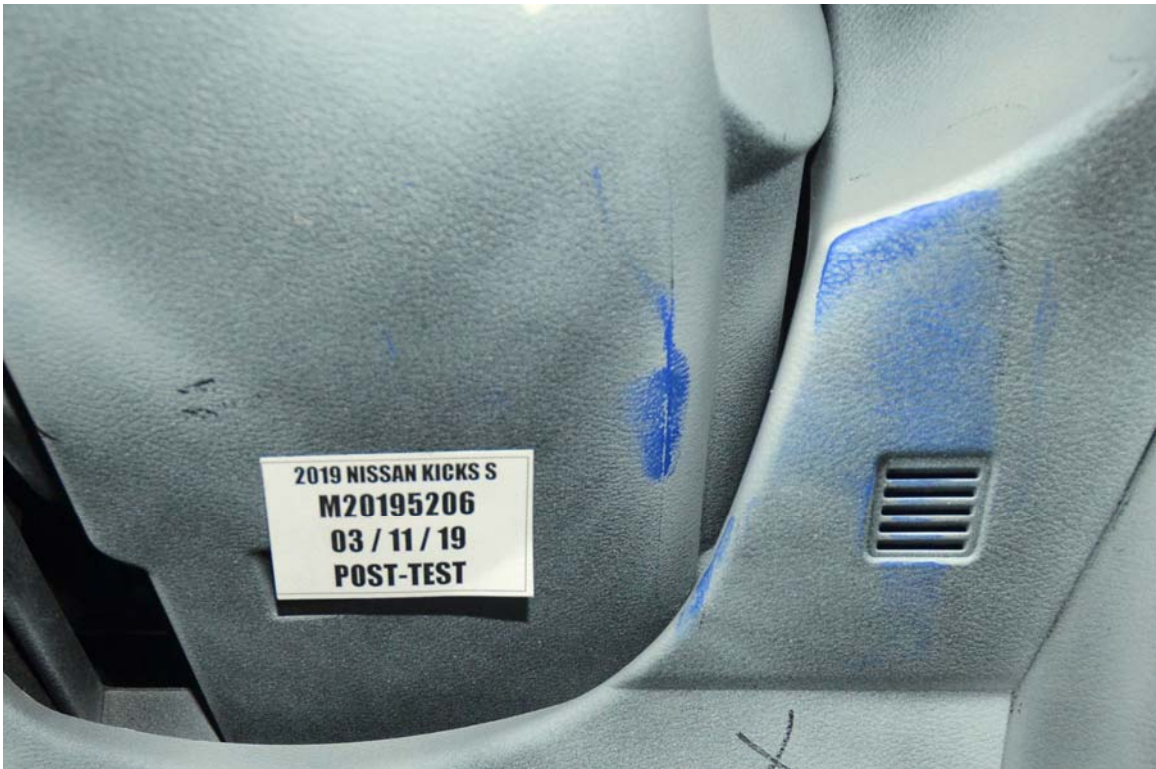

FIGURE 48b. Post-Test Driver Dummy Contact with Steering Column



FIGURE 49. Pre-Test View of the Steering Wheel



FIGURE 50. Post-Test View of the Steering Wheel



FIGURE 51. Pre-Test Passenger Dummy Front View



FIGURE 52. Post-Test Passenger Dummy Front View



FIGURE 53. Pre-Test Passenger Dummy Window View



FIGURE 54. Post-Test Passenger Dummy Window View



FIGURE 55. Pre-Test Passenger Dummy and Vehicle Interior View



FIGURE 56. Post-Test Passenger Dummy and Vehicle Interior View



FIGURE 57. Pre-Test Passenger's Seat Fore-Aft Markings



FIGURE 58. Post-Test Passenger's Seat Fore-Aft Markings



FIGURE 59. Pre-Test View of Belt Anchorage for Passenger Dummy



FIGURE 60. Post-Test View of Belt Anchorage for Passenger Dummy



FIGURE 61. Pre-Test Passenger Dummy Feet



FIGURE 62. Post-Test Passenger Dummy Feet



FIGURE 63. Pre-Test Passenger's Side Knee Bolster



FIGURE 64. Post-Test Passenger's Side Knee Bolster



FIGURE 65. Pre-Test Passenger's Side Floorpan



FIGURE 66. Post-Test Passenger's Side Floorpan



FIGURE 67. Post-Test Passenger Dummy Face



FIGURE 68. Post-Test Passenger Dummy Contact with Airbag



FIGURE 69. Post-Test Passenger Dummy Contact with Headrest



FIGURE 69a. Post-Test Passenger Dummy Contact with Glove Box

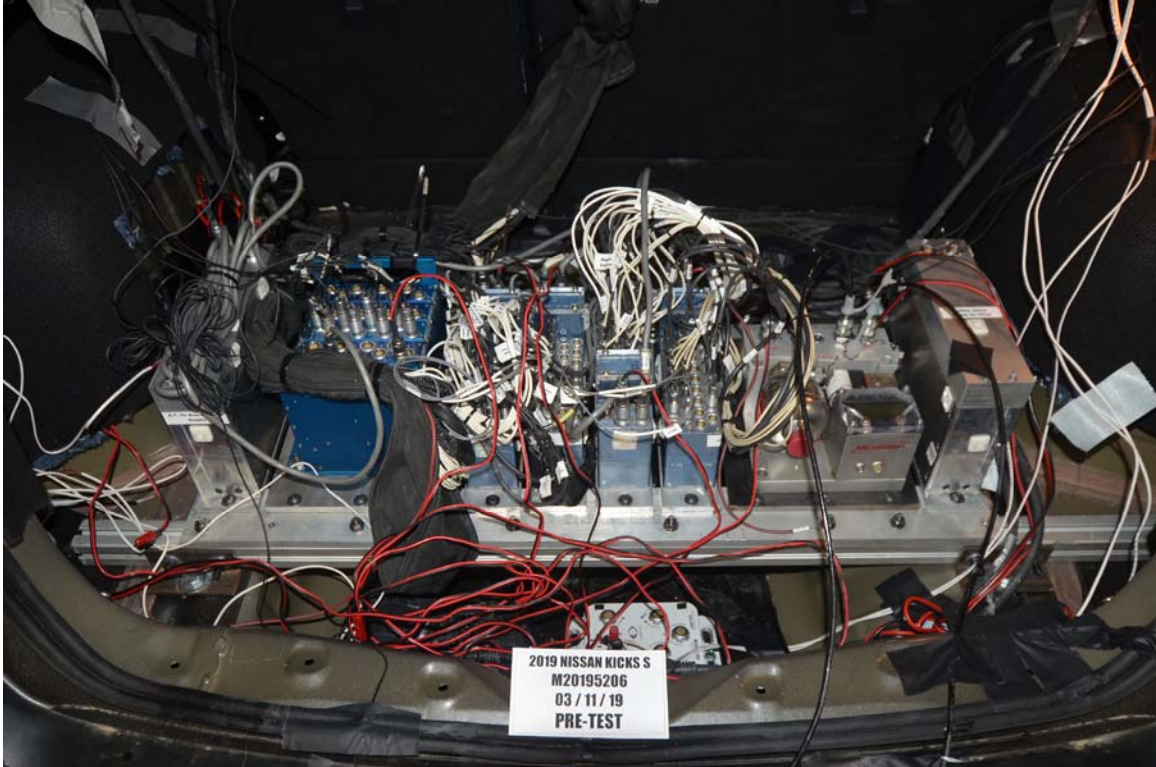

FIGURE 70. Photograph of Ballast Installed in Vehicle

Photograph Not Applicable

**No Stoddard
Solvent Spillage**

FIGURE 71. Post-Test Stoddard Solvent Spillage Location View



FIGURE 72. Post-Test Speed Trap Read-Out



FIGURE 73. Vehicle at 0° on Static Rollover Device



FIGURE 74. Vehicle at 90° on Static Rollover Device



FIGURE 75. Vehicle at 180° on Static Rollover Device



FIGURE 76. Vehicle at 270° on Static Rollover Device



FIGURE 77. Vehicle at 360° on Static Rollover Device



FIGURE 78. 2019 Nissan Kicks S Frontal Impact Event

<h2>2019 NISSAN KICKS S CVT</h2>		<p>Scan QR code for general model information & options</p>	<h3>Fuel Economy and Environment</h3> <p>33 MPG combined city/hwy</p> <p>31 city 36 highway</p> <p>3.0 gallons per 100 miles</p> <p>You Save \$1,250 in fuel costs over 5 years compared to the average new vehicle.</p>
<p>MECHANICAL & PERFORMANCE</p> <ul style="list-style-type: none"> 1.6 L DOHC 16-Valve 4-Cylinder Engine Xtronic CVT (Continuously Variable Transmission) Power-Assisted Vented Front Disc / Rear Drum Brakes 16" Steel Wheels w/ Full Wheel Covers Hill Start Assist 	<p>COMFORT & CONVENIENCE</p> <ul style="list-style-type: none"> Cruise Control with Steering Wheel Mounted Controls Manual Air Conditioning Remote Keyless Entry w/ Push Button Start 7" Color Touchscreen Display Audio System w/ 8 Speakers Bluetooth® Hands-free Phone System+ Streaming audio via Bluetooth® Star Eyes Free+ Audio and Bluetooth® Steering Wheel Switches 3 USB Ports (2 charge only) Rear-View Monitor (RVM) Tilt/Telescoping Steering Wheel Power Windows 1 Touch Up/Down (Driver & Front Passenger) 4-Way Adjustable Cloth Front Bucket Seats Power Door Locks w/ Auto-Locking Feature Driver Seat Armrest and Seat Lifter 60/40 Split Rear Seats 	<p>Manufacturer's Suggested Retail Base Price: \$16,540.00</p> <p>Options Included by Manufacturer: SPLASH GUARDS \$170.00, CARPETED FLOOR MATS & CARGO MAT \$215.00, DOOR SILL PLATES \$90.00</p> <p>DESTINATION CHARGES: 1,045.00</p> <p>Total: \$20,060.00</p>	<p>Annual fuel cost \$1,150</p> <p>Fuel Economy & Greenhouse Gas Rating (mpg) (est.) Smog Rating (state) (est.)</p> <p>1 8 10 9 7 10</p> <p>This vehicle emits 271 grams CO₂ per mile. The best emits 6 grams per mile (zero smog). Producing and distributing fuel also create emissions. Learn more at fuelconomy.gov</p>
<p>SAFETY & SECURITY</p> <ul style="list-style-type: none"> Dual-Stage Supplemental Driver and Front Passenger Air Bags Front Seat-Mounted Side Impact Supplemental Air Bags Side Impact Supplemental Curtain Air Bags w/ Roll-over Sensor Driver Knee Supplemental Air Bag Anti-lock Braking System (ABS) Traction Control System (TCS) Vehicle Dynamic Control (VDC) Electronic Brake force Distribution (EBD) Tire Pressure Monitoring System (TPMS) w/ Easy Fill Tire Alert Nissan Vehicle Immobilizer System Automatic Emergency Braking (AEB) 	<p>EXTERIOR</p> <ul style="list-style-type: none"> Roof Rails w/ Silver Paint Manual Folding Power Outside Mirrors Front and Rear Bumper with Black Fascia Accent Versatile Intermittent Wipers w/ Mist Rear Wiper Intelligent Auto Headlights (I-AH) 	<p>GOVERNMENT 5-STAR SAFETY RATINGS</p> <p>Overall Vehicle Score Not Rated Based on the combined ratings of frontal, side and rollover. Should ONLY be compared to other vehicles of similar size and weight.</p> <p>Frontal Crash Driver Not Rated, Passenger Not Rated Based on the risk of injury in a frontal impact. Should ONLY be compared to other vehicles of similar size and weight.</p> <p>Side Crash Front seat Not Rated, Rear seat Not Rated Based on the risk of injury in a side impact.</p> <p>Rollover Not Rated Based on the risk of rollover in a single-vehicle crash.</p>	<p>DELIVERY</p> <p>VEHICLE COLORS: EXT: GUN METAL L/C, INT: CHARCOAL</p> <p>FINAL ASSEMBLY POINT: AGUAS (ABV) MEX TRUCK</p> <p>TRANSPORT METHOD: TRUCK</p> <p>DEALER: METRO NISSAN OF MONTCLAIR, 8440 ALTOPEX DRIVE, MONTCLAIR, CA 91763</p>
<p>*Does not include dealer installed options and accessories, local taxes or license fees. This label has been applied pursuant to federal law. Do not remove prior to delivery to the ultimate purchaser.</p>		<p>Star ratings range from 1 to 5 stars (*****), with 5 being the highest. Source: National Highway Traffic Safety Administration (NHTSA) www.safercar.gov or 1-888-327-4236</p> <p>This Vehicle qualifies for Nissan's Security+Plus Extended Protection Plan. The only service agreement backed by Nissan Extended Services North America! Ask your dealer for details, or call 1-800-NISSAN-1 for more information.</p> <p>VIN: 3N1C750U9L481704 EMS: 00 STATE EMISSIONS MDL: 21015-481704_KAD-G OPT: 0-380200L0N0V3</p>	

FIGURE 79. Monroney Label Photograph

APPENDIX B
DUMMY RESPONSE DATA TRACES

TABLE OF DATA PLOTS

Plot		Page
1	Driver Head Acceleration X Primary	B-1
2	Driver Head Acceleration Y Primary	B-1
3	Driver Head Acceleration Z Primary	B-1
4	Driver Head Resultant Acceleration Primary	B-1
5	Driver Chest X Deflection	B-2
6	Driver Chest Acceleration X Primary	B-3
7	Driver Chest Acceleration Y Primary	B-3
8	Driver Chest Acceleration Z Primary	B-3
9	Driver Chest Resultant Acceleration Primary	B-3
10	Driver Upper Neck Force X	B-4
11	Driver Upper Neck Force Z	B-4
12	Driver Upper Neck Moment Y	B-4
13	Driver Nij	B-4
14	Driver Left Femur Force Z	B-5
15	Driver Right Femur Force Z	B-5
16	Passenger Head Acceleration X Primary	B-6
17	Passenger Head Acceleration Y Primary	B-6
18	Passenger Head Acceleration Z Primary	B-6
19	Passenger Head Resultant Acceleration Primary	B-6
20	Passenger Chest X Deflection	B-7
21	Passenger Chest Acceleration X Primary	B-8
22	Passenger Chest Acceleration Y Primary	B-8
23	Passenger Chest Acceleration Z Primary	B-8
24	Passenger Chest Resultant Acceleration Primary	B-8
25	Passenger Upper Neck Force X	B-9
26	Passenger Upper Neck Force Z	B-9
27	Passenger Upper Neck Moment Y	B-9
28	Passenger Nij	B-9
29	Passenger Left Femur Force Z	B-10
30	Passenger Right Femur Force Z	B-10

The following additional dummy and vehicle response data can be found in the R&D section of the NHTSA website at www.nhtsa.gov

Driver Head X Acceleration Redundant
Driver Head Y Acceleration Redundant
Driver Head Z Acceleration Redundant
Driver Upper Neck Force Y
Driver Upper Neck Moment X
Driver Upper Neck Moment Z
Driver Chest X Acceleration Redundant
Driver Chest Y Acceleration Redundant
Driver Chest Z Acceleration Redundant
Driver Pelvis X
Driver Pelvis Y
Driver Pelvis Z
Driver Left Femur Force Z Redundant
Driver Right Femur Force Z Redundant
Driver Left Upper Tibia Moment X
Driver Left Upper Tibia Moment Y
Driver Left Upper Tibia Force Z
Driver Left Lower Tibia Moment X
Driver Left Lower Tibia Moment Y
Driver Left Lower Tibia Force Z
Driver Right Upper Tibia Moment X
Driver Right Upper Tibia Moment Y
Driver Right Upper Tibia Force Z
Driver Right Lower Tibia Moment X
Driver Right Lower Tibia Moment Y
Driver Right Lower Tibia Force Z
Driver Left Foot Fore Z
Driver Left Foot Aft X
Driver Left Foot Aft Z
Driver Right Foot Fore Z
Driver Right Foot Aft X
Driver Right Foot Aft Z
Driver Shoulder Belt Force
Driver Lap Belt Force
Passenger Head X Acceleration Redundant
Passenger Head Y Acceleration Redundant
Passenger Head Z Acceleration Redundant
Passenger Upper Neck Force X
Passenger Upper Neck Force Z
Passenger Upper Neck Moment Y
Passenger Chest X Acceleration Redundant
Passenger Chest Y Acceleration Redundant
Passenger Chest Z Acceleration Redundant

Passenger Pelvis X
Passenger Pelvis Y
Passenger Pelvis Z
Passenger Left Femur Force Redundant
Passenger Right Femur Force Redundant
Passenger Left Upper Tibia Moment X
Passenger Left Upper Tibia Moment Y
Passenger Left Upper Tibia Force Z
Passenger Left Lower Tibia Moment X
Passenger Left Lower Tibia Moment Y
Passenger Left Lower Tibia Force Z
Passenger Right Upper Tibia Moment X
Passenger Right Upper Tibia Moment Y
Passenger Right Upper Tibia Force Z
Passenger Right Lower Tibia Moment X
Passenger Right Lower Tibia Moment Y
Passenger Right Lower Tibia Force Z
Passenger Left Foot Fore Z
Passenger Left Foot Aft X
Passenger Left Foot Aft Z
Passenger Right Foot Fore Z
Passenger Right Foot Aft X
Passenger Right Foot Aft Z
Passenger Shoulder Belt Force
Passenger Lap Belt Force
Left Rear Seat Crossmember X
Left Rear Seat Crossmember Z
Right Rear Seat Crossmember X
Right Rear Seat Crossmember Z
Left Rear Seat Crossmember X Redundant
Right Rear Seat Crossmember X Redundant
Vehicle Engine Top X
Vehicle Engine Bottom X
Load Cell Barrier Forces and Moments

Test Vehicle: 2019 Nissan Kicks S 5-Door SUV
 Test Program: 56.3 km/h Frontal Impact NCAP Test

NHTSA No.: M20195206
 Test Date: 3/11/2019

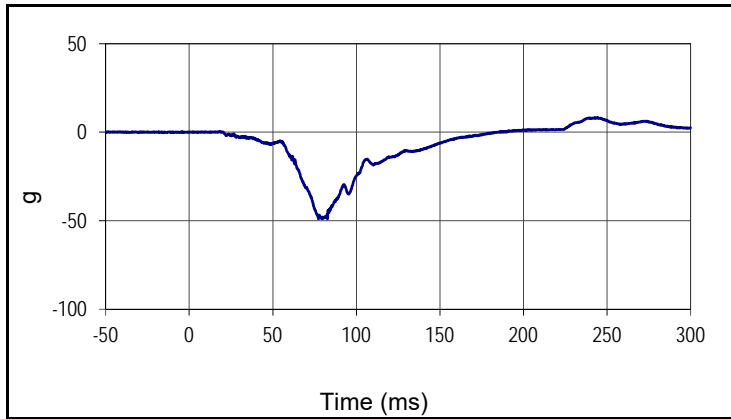

Curve Description			
Driver Head Acceleration X Primary			
Plot No.		SAE Class	Units
001		1000	g
Max	Time	Min	Time
8.3	243.9	-49.0	82.7

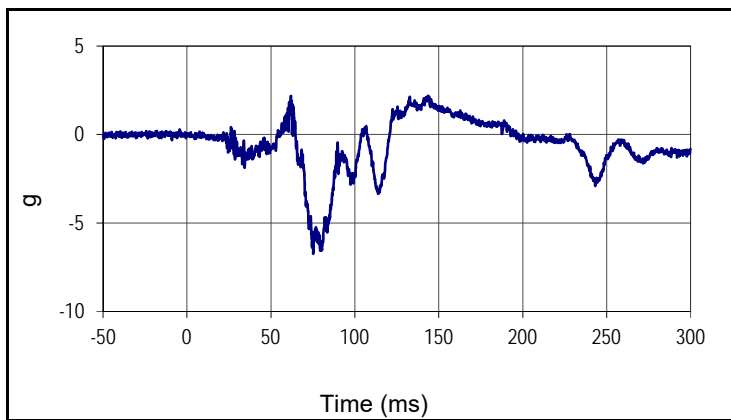

Curve Description			
Driver Head Acceleration Y Primary			
Plot No.		SAE Class	Units
002		1000	g
Max	Time	Min	Time
2.2	143.6	-6.7	75.2

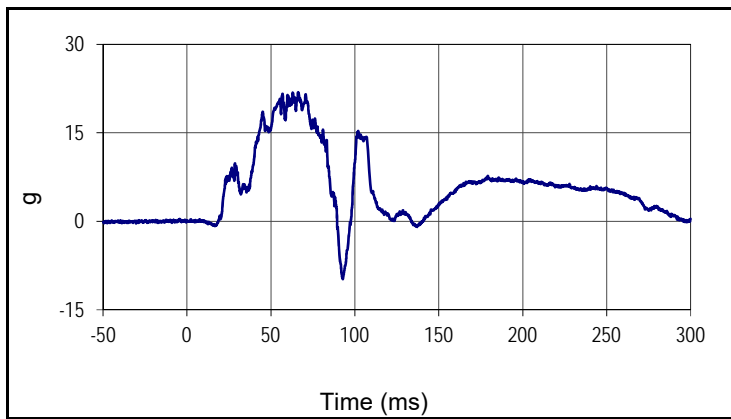

Curve Description			
Driver Head Acceleration Z Primary			
Plot No.		SAE Class	Units
003		1000	g
Max	Time	Min	Time
21.9	66.1	-9.8	92.8

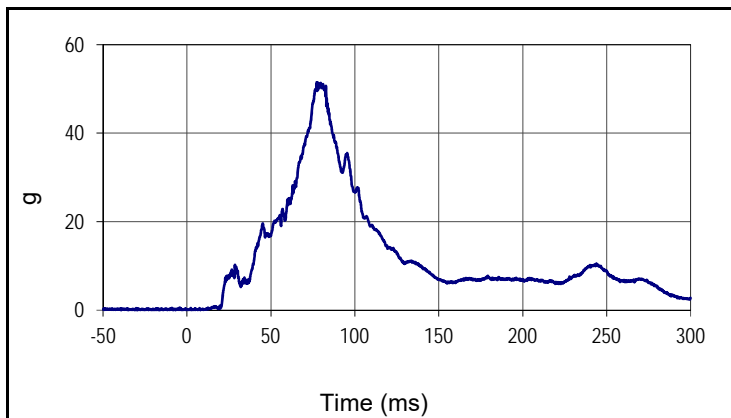

Curve Description			
Driver Head Resultant Acceleration Primary			
Plot No.		SAE Class	Units
004		1000	g
Max	Time	Min	Time
51.5	77.2	0.0	8.0

Test Vehicle: 2019 Nissan Kicks S 5-Door SUV
 Test Program: 56.3 km/h Frontal Impact NCAP Test

NHTSA No.: M20195206
 Test Date: 3/11/2019

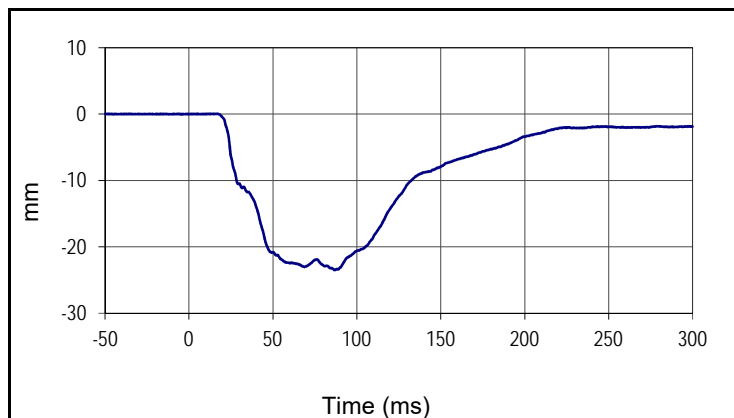

Curve Description			
Driver Chest Deflection			
Plot No.		SAE Class	Units
005		600	mm
Max	Time	Min	Time
0.0	16.6	-23.5	86.9

Test Vehicle: 2019 Nissan Kicks S 5-Door SUV
 Test Program: 56.3 km/h Frontal Impact NCAP Test

NHTSA No.: M20195206
 Test Date: 3/11/2019

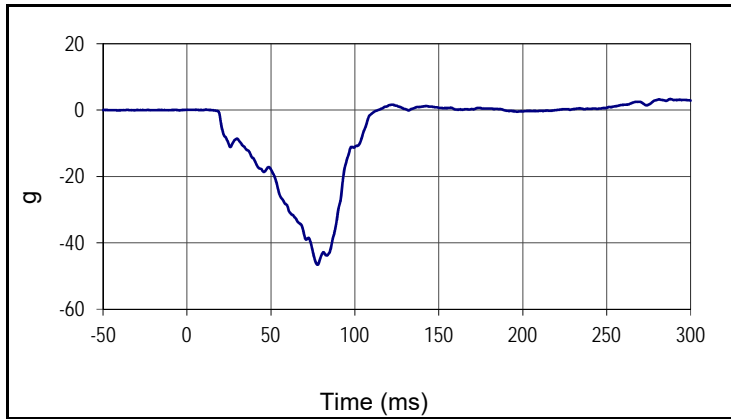

Curve Description			
Driver Chest Acceleration X Primary			
Plot No.		SAE Class	Units
006		180	g
Max	Time	Min	Time
3.3	287.8	-46.6	77.7

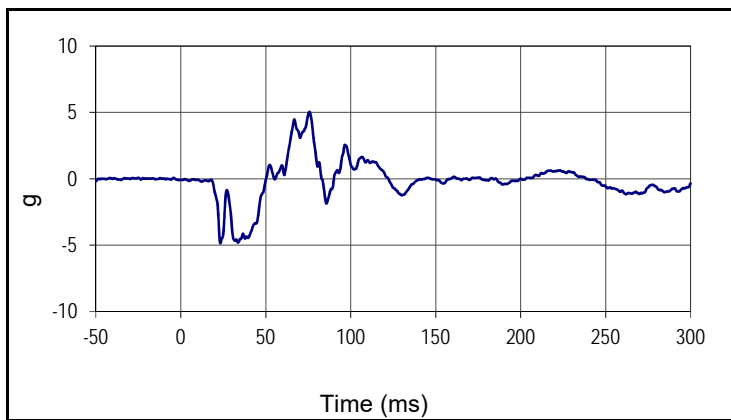

Curve Description			
Driver Chest Acceleration Y Primary			
Plot No.		SAE Class	Units
007		180	g
Max	Time	Min	Time
5.0	75.7	-4.9	23.2

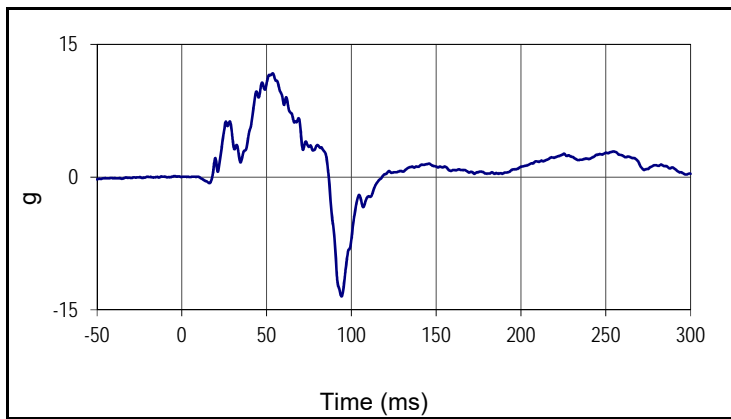

Curve Description			
Driver Chest Acceleration Z Primary			
Plot No.		SAE Class	Units
008		180	g
Max	Time	Min	Time
11.7	53.6	-13.5	94.1

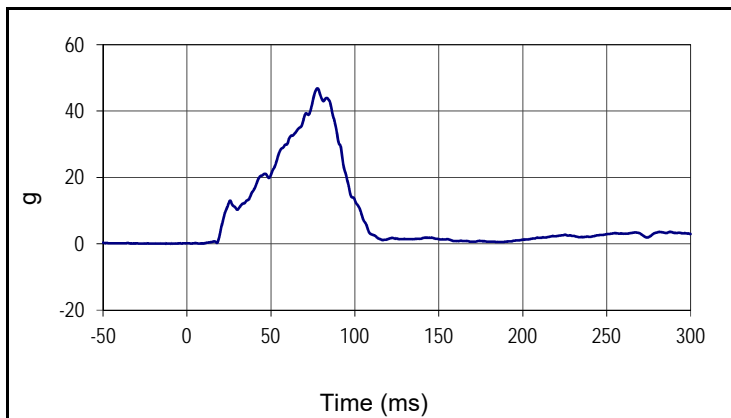

Curve Description			
Driver Chest Resultant Acceleration Primary			
Plot No.		SAE Class	Units
009		180	g
Max	Time	Min	Time
46.9	77.7	0.1	7.2

Test Vehicle: 2019 Nissan Kicks S 5-Door SUV
 Test Program: 56.3 km/h Frontal Impact NCAP Test

NHTSA No.: M20195206
 Test Date: 3/11/2019

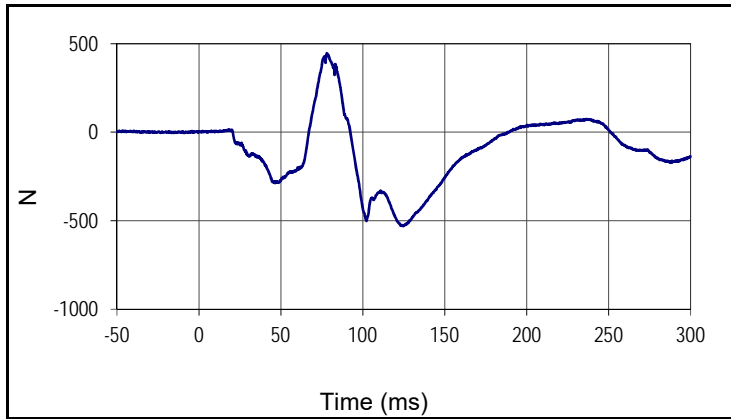

Curve Description			
Driver Upper Neck Force X			
Plot No.		SAE Class	Units
010		1000	N
Max	Time	Min	Time
446.3	78.0	-530.5	124.6

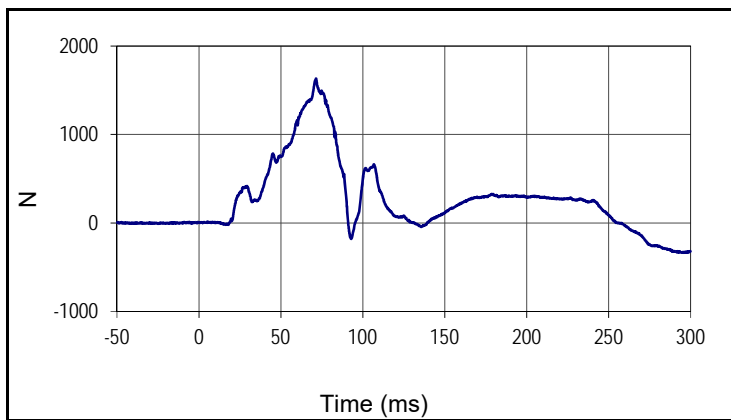

Curve Description			
Driver Upper Neck Force Z			
Plot No.		SAE Class	Units
011		1000	N
Max	Time	Min	Time
1631.6	71.4	-335.6	294.4

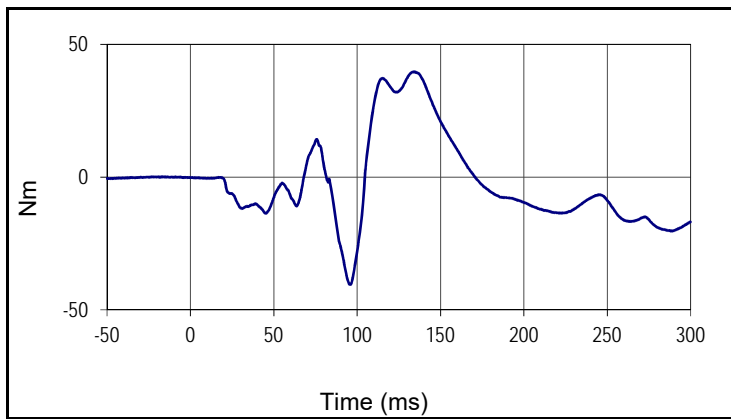

Curve Description			
Driver Upper Neck Moment Y			
Plot No.		SAE Class	Units
012		600	Nm
Max	Time	Min	Time
39.7	133.7	-40.5	95.9

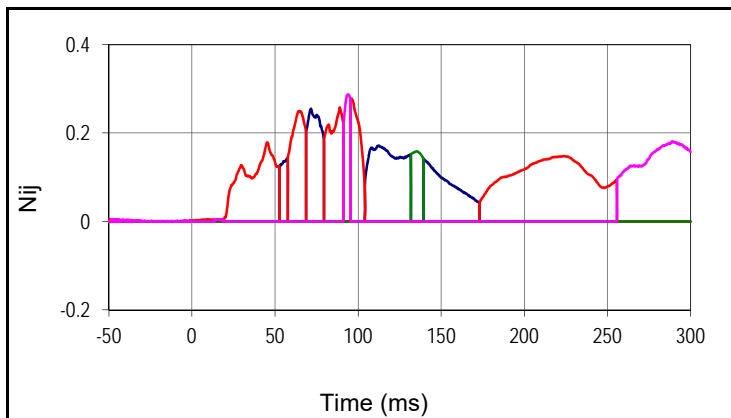

Curve Description		
Driver Nij		
Units	Max	Time
Ntf	0.26	71.5
Nte	0.28	96.0
Ncf	0.16	135.2
Nce	0.29	93.7

Test Vehicle: 2019 Nissan Kicks S 5-Door SUV
 Test Program: 56.3 km/h Frontal Impact NCAP Test

NHTSA No.: M20195206
 Test Date: 3/11/2019

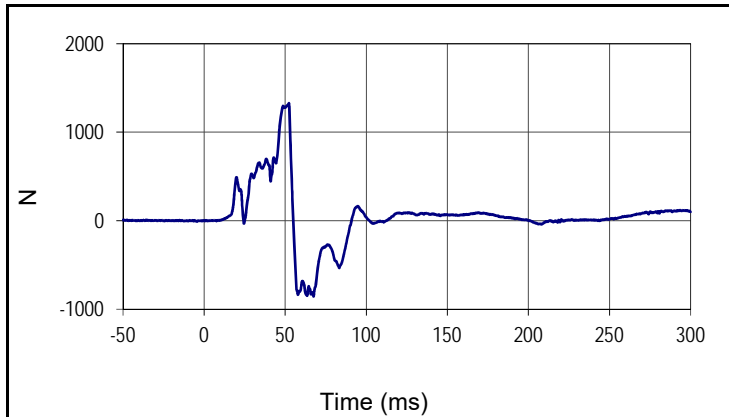

Curve Description			
Driver Left Femur Force Z			
Plot No.		SAE Class	Units
014		600	N
Max	Time	Min	Time
1328.1	52.3	-856.8	67.5

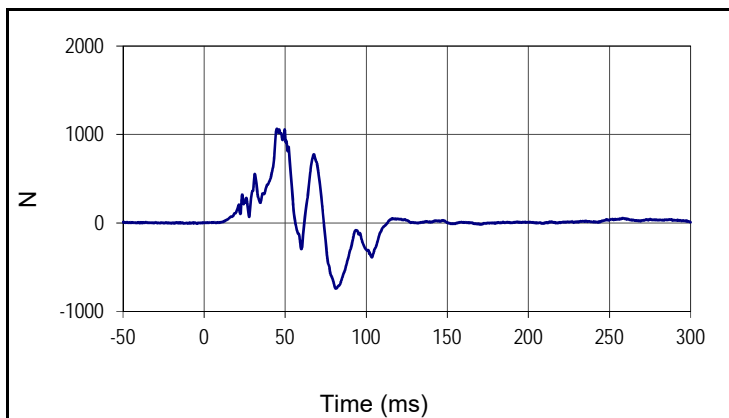

Curve Description			
Driver Right Femur Force Z			
Plot No.		SAE Class	Units
015		600	N
Max	Time	Min	Time
1064.1	44.9	-741.7	81.2

Test Vehicle: 2019 Nissan Kicks S 5-Door SUV
 Test Program: 56.3 km/h Frontal Impact NCAP Test

NHTSA No.: M20195206
 Test Date: 3/11/2019

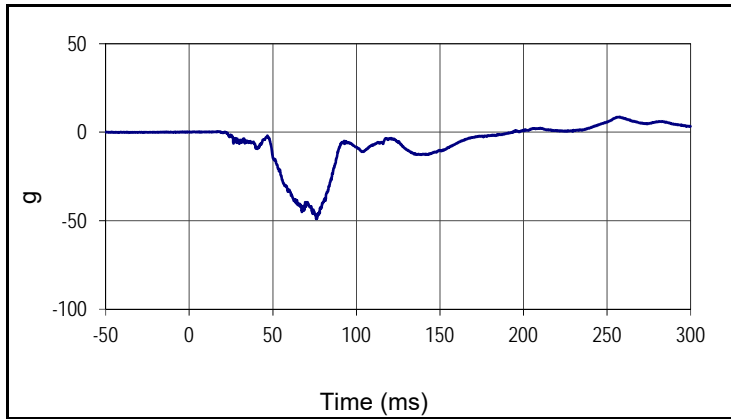

Curve Description			
Passenger Head Acceleration X Primary			
Plot No.		SAE Class	Units
016		1000	g
Max	Time	Min	Time
8.6	257.4	-48.9	76.0

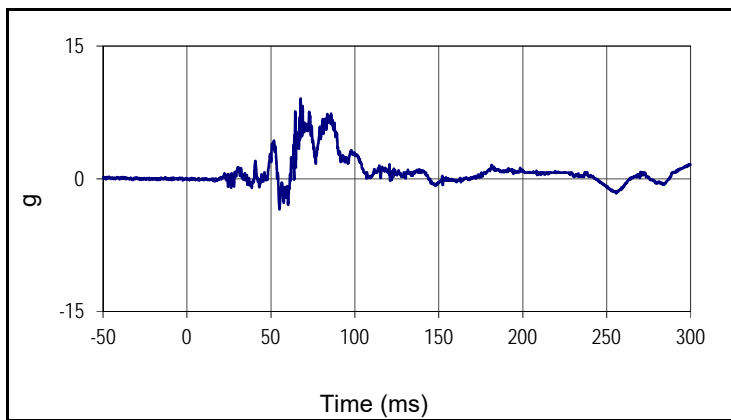

Curve Description			
Passenger Head Acceleration Y Primary			
Plot No.		SAE Class	Units
017		1000	g
Max	Time	Min	Time
9.1	67.7	-3.5	55.1

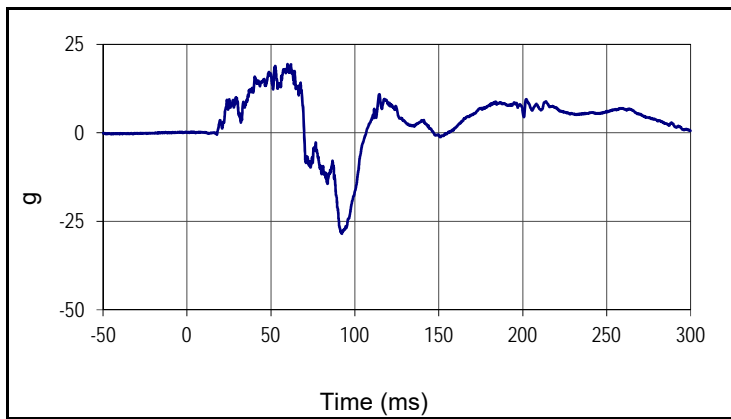

Curve Description			
Passenger Head Acceleration Z Primary			
Plot No.		SAE Class	Units
018		1000	g
Max	Time	Min	Time
19.4	59.9	-28.5	92.2

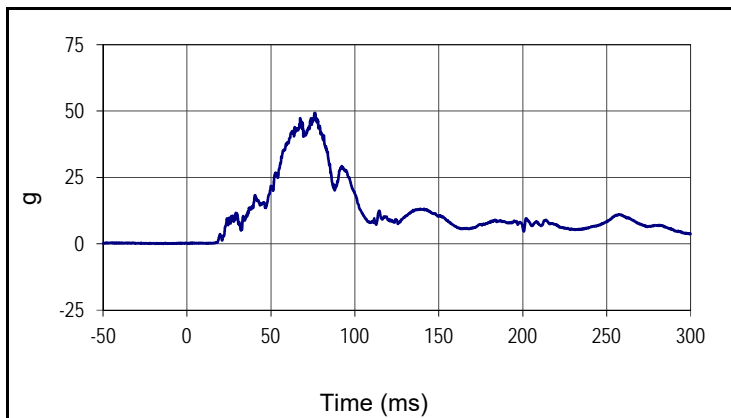

Curve Description			
Passenger Head Resultant Acceleration Primary			
Plot No.		SAE Class	Units
019		1000	g
Max	Time	Min	Time
49.2	76.0	0.1	1.2

Test Vehicle: 2019 Nissan Kicks S 5-Door SUV
 Test Program: 56.3 km/h Frontal Impact NCAP Test

NHTSA No.: M20195206
 Test Date: 3/11/2019

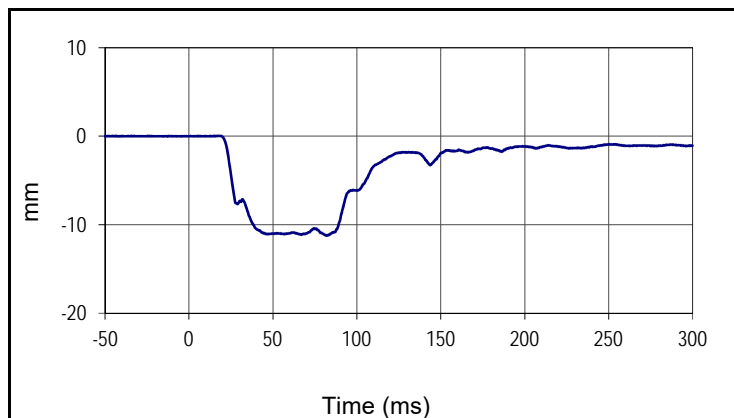

Curve Description			
Passenger Chest Deflection			
Plot No.		SAE Class	Units
020		600	mm
Max	Time	Min	Time
0.0	18.9	-11.2	81.9

Test Vehicle: 2019 Nissan Kicks S 5-Door SUV
 Test Program: 56.3 km/h Frontal Impact NCAP Test

NHTSA No.: M20195206
 Test Date: 3/11/2019

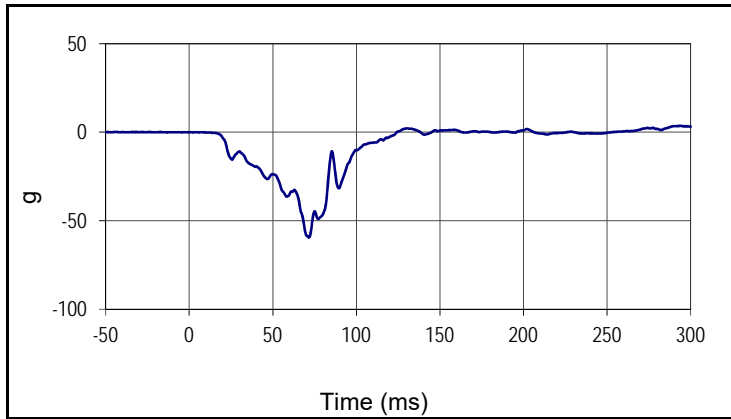

Curve Description			
Passenger Chest Acceleration X Primary			
Plot No.		SAE Class	Units
021		180	g
Max	Time	Min	Time
3.6	293.9	-59.5	71.6

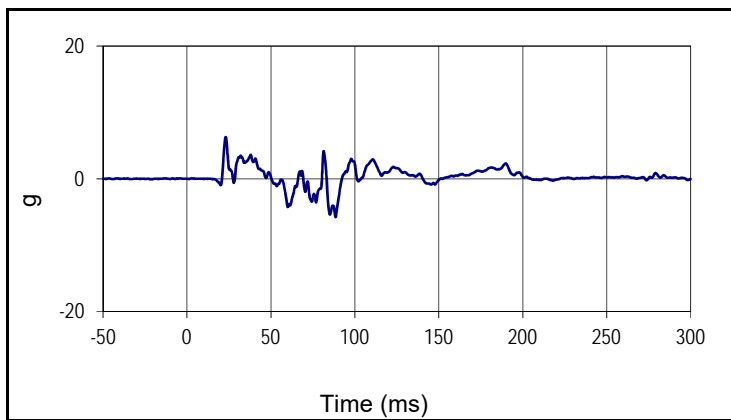

Curve Description			
Passenger Chest Acceleration Y Primary			
Plot No.		SAE Class	Units
022		180	g
Max	Time	Min	Time
6.3	23.1	-5.8	88.5

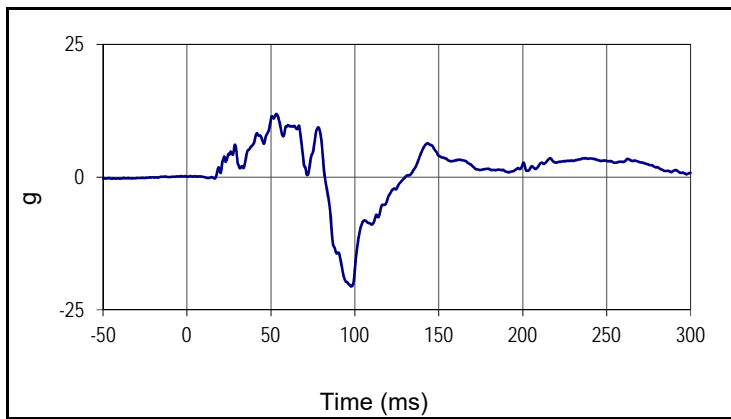

Curve Description			
Passenger Chest Acceleration Z Primary			
Plot No.		SAE Class	Units
023		180	g
Max	Time	Min	Time
11.9	53.2	-20.6	97.8

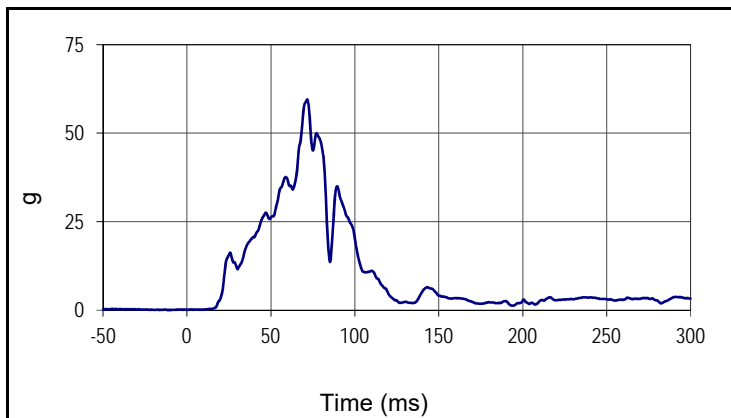

Curve Description			
Passenger Chest Resultant Acceleration Primary			
Plot No.		SAE Class	Units
024		180	g
Max	Time	Min	Time
59.5	71.6	0.1	0.4

Test Vehicle: 2019 Nissan Kicks S 5-Door SUV
 Test Program: 56.3 km/h Frontal Impact NCAP Test

NHTSA No.: M20195206
 Test Date: 3/11/2019

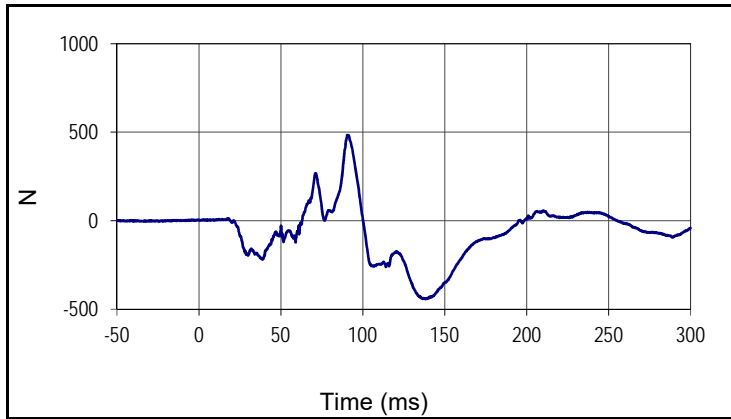

Curve Description			
Passenger Upper Neck Force X			
Plot No.		SAE Class	Units
025		1000	N
Max	Time	Min	Time
483.8	90.5	-442.5	137.9

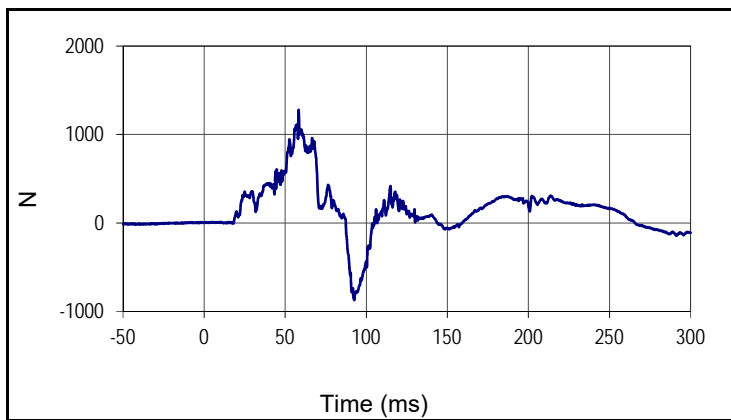

Curve Description			
Passenger Upper Neck Force Z			
Plot No.		SAE Class	Units
026		1000	N
Max	Time	Min	Time
1278.6	58.3	-871.3	92.6

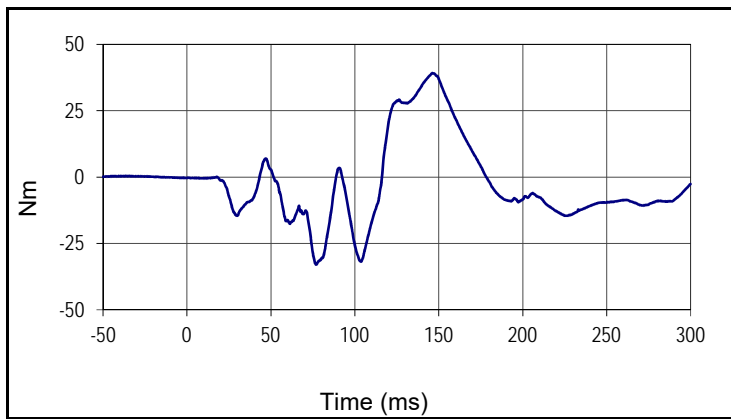

Curve Description			
Passenger Upper Neck Moment Y			
Plot No.		SAE Class	Units
027		600	Nm
Max	Time	Min	Time
39.2	146.1	-33.0	76.9

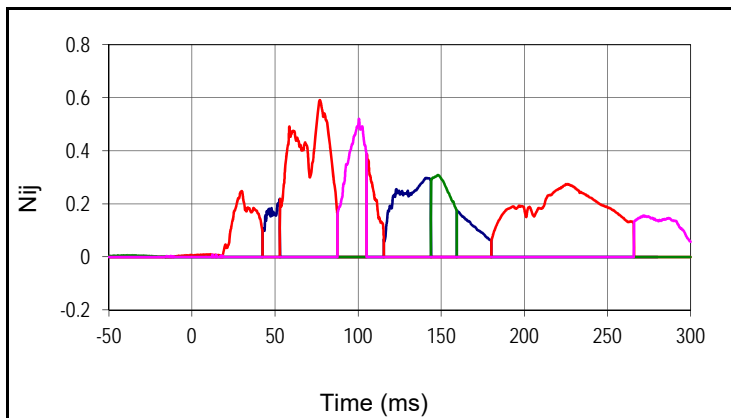

Curve Description		
Passenger Nij		
Units	Max	Time
Ntf	0.30	141.1
Units	Max	Time
Nte	0.59	76.8
Units	Max	Time
Ncf	0.31	147.9
Units	Max	Time
Nce	0.52	100.4

Test Vehicle: 2019 Nissan Kicks S 5-Door SUV
 Test Program: 56.3 km/h Frontal Impact NCAP Test

NHTSA No.: M20195206
 Test Date: 3/11/2019

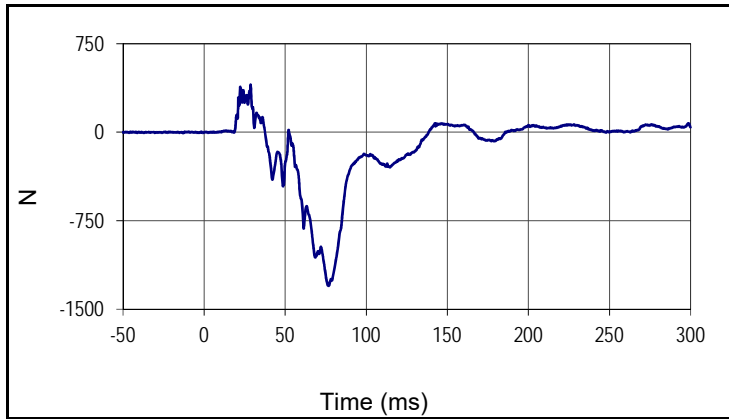

Curve Description			
Passenger Left Femur Force Z			
Plot No.		SAE Class	Units
029		600	N
Max	Time	Min	Time
402.8	28.7	-1302.8	76.8

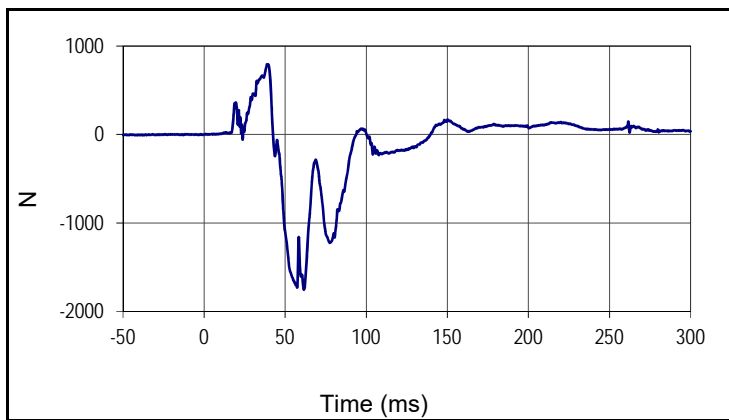

Curve Description			
Passenger Right Femur Force Z			
Plot No.		SAE Class	Units
030		600	N
Max	Time	Min	Time
795.5	38.9	-1753.8	61.5

APPENDIX C
ATD CALIBRATION AND PERFORMANCE VERIFICATION DATA

APPENDIX C
Pre-Test ATD Configuration And Performance Verification Data
Hybrid III 50th Percentile Male ATD
S/N: 360

ATD Serial No.: 360

Test Date: 2019-02-15

Dummy Item	Inspect for	Comments	Damage	OK
Entire ATD	Perform general cleaning			✓
Outer Skin	Gashes, rips, cracks			✓
Head	Ballast secure			✓
	General appearance			✓
Neck bracket	Upper neck firmly attached to lower bracket			✓
Neck	Broken or cracked rubber			✓
	Looseness at the condyle joint			✓
Nodding block	Cracked or out of position			✓
Lumbar Spine	Broken or cracked rubber			✓
Ribs	Broken or bent ribs			✓
	Broken or bent rib supports			✓
	Damping material separated or cracked			✓
	Rubber bumpers in place			✓
Chest Displ. Assembly	Bent shaft			✓
	Slider arm riding in track			✓
Sensors	Check cables for cuts, tears			✓
	Check for damaged insulation			✓
Accelerometer Mounting	Head mounting secure			✓
	Chest mounting secure			✓
Knees	Skin condition			✓
	Insert (do not remove)			✓
	Casting			✓
Limbs	Normal movement and adjustment			✓
Knee Sliders	Wires intact			✓
	Rubber returned to "resting" position			✓
Pelvis	Broken			✓
Other	Describe below as needed			✓

Describe any repairs or replacement of parts or other findings:

No Problems Found

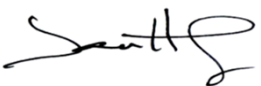
Technician: 
J. Hernandez

Approved By: 
P. Puzzuto

Tested Parameter	Units	Spec. Low	Spec. High	Result	Pass/Fail
Laboratory Temperature	°C	20.6	22.2	21.4	Pass
Laboratory Relative Humidity	%	10	70	26	Pass
A - Total sitting height	mm	879	889	884	Pass
B - Shoulder pivot height	mm	505	521	519	Pass
C - 'H' point height	mm	84	89	87	Pass
D - 'H' point location from backline	mm	135	140	137	Pass
E - Shoulder pivot from backline	mm	84	94	88	Pass
F - Thigh clearance	mm	140	155	147	Pass
G - Back of elbow to wrist pivot	mm	290	305	301	Pass
H - Head back to backline	mm	41	46	46	Pass
I - Shoulder to elbow length	mm	330	345	341	Pass
J - Elbow rest height	mm	190	211	197	Pass
K - Buttock to knee length	mm	579	604	591	Pass
L - Popliteal length	mm	429	455	445	Pass
M - Knee pivot height	mm	485	500	492	Pass
N - Buttock popliteal length	mm	452	477	463	Pass
O - Chest depth without jacket	mm	213	229	220	Pass
P - Foot length	mm	251	267	259	Pass
V - Shoulder breadth	mm	422	437	434	Pass
W - Foot breadth	mm	91	107	105	Pass
Y - Chest circum. (w/chest jacket)	mm	970	1001	989	Pass
Z - Waist circum.	mm	836	866	847	Pass
AA - Location for chest circum.	mm	429	434	433	Pass
BB - Location for waist circum.	mm	226	231	228	Pass
Overall Test Results					Pass

Technician: _____



J. Hernandez

Approved By: _____



P. Puzzuto

Tested Parameter	Units	Spec. Low	Spec. High	Result	Pass/Fail
Laboratory Temperature	°C	18.9	25.6	21.1	Pass
Laboratory Humidity	%	10	70	22	Pass
Peak Resultant Acceleration	g	225.0	275.0	263.0	Pass
Peak Lateral Acceleration	g	-15.0	15.0	-6.6	Pass
Oscillations After Main Pulse	%	0.0	10.0	2.6	Pass
Is Acceleration Unimodal?	Yes/No	Yes		Yes	Pass
Overall Test Results					Pass

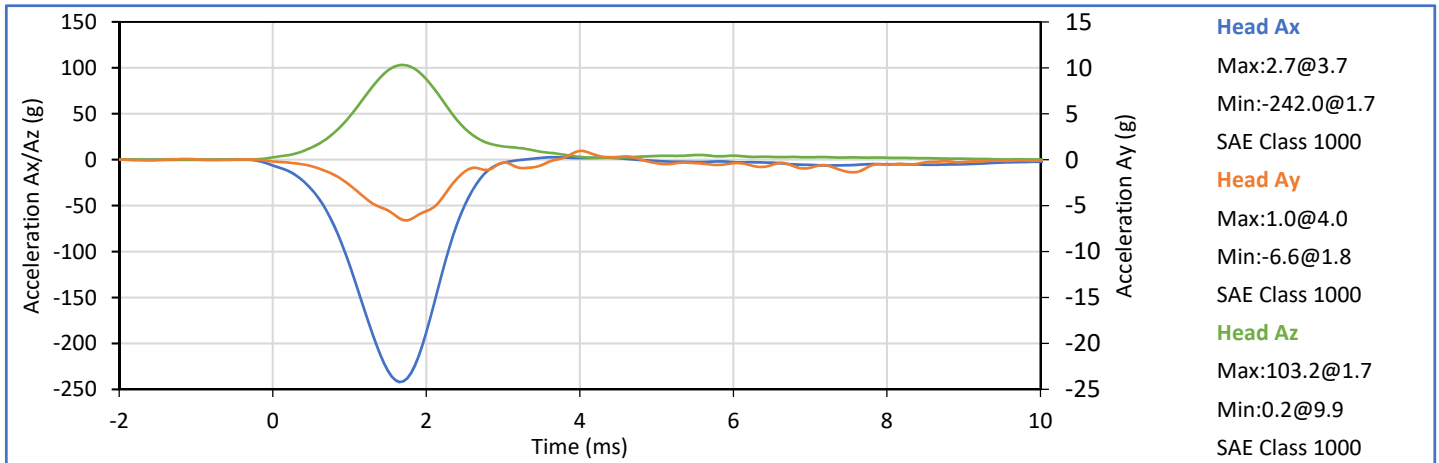
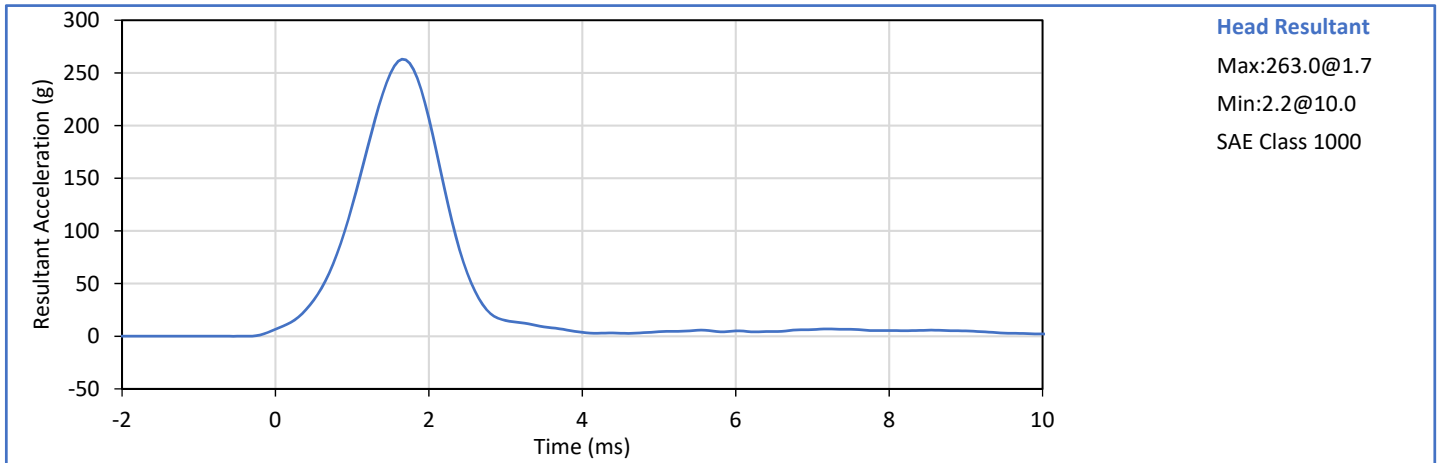

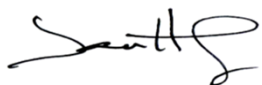

Technician: 
J. Hernandez

Approved By: 
P. Puzzuto

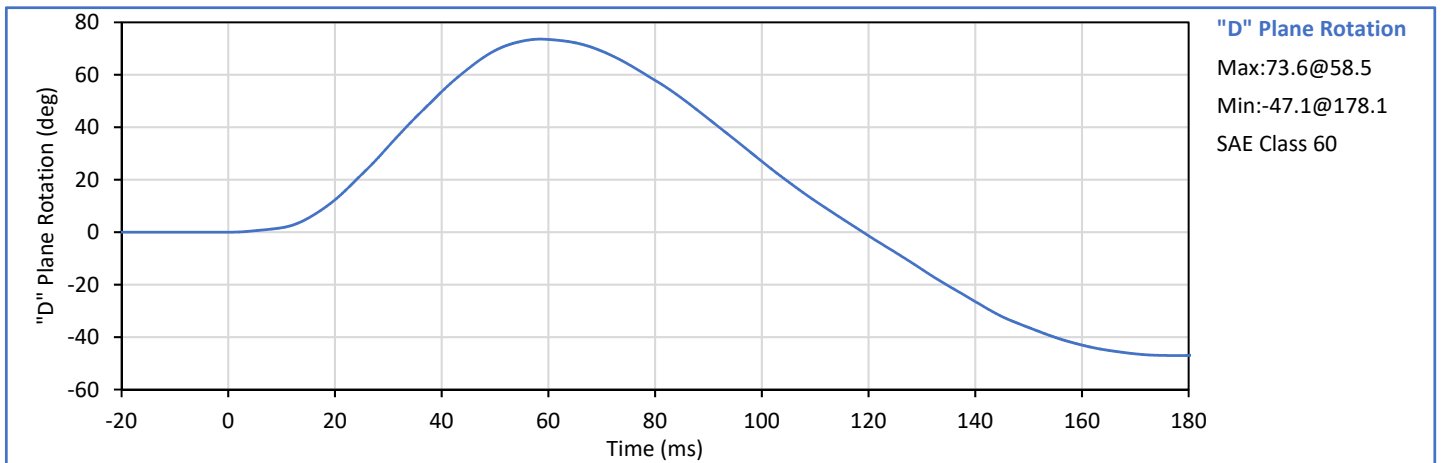
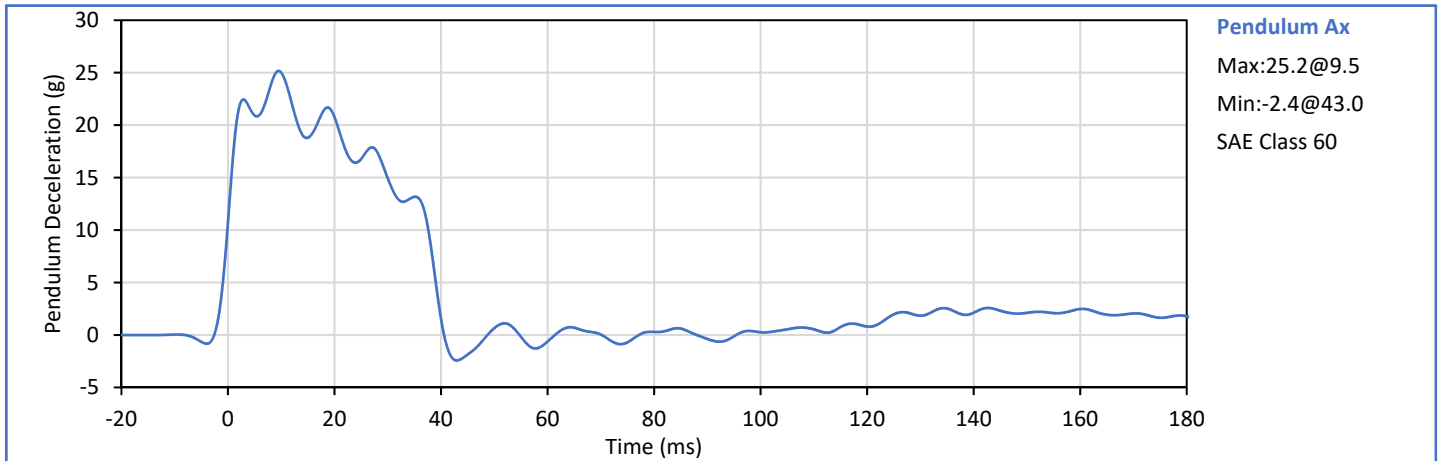
Tested Parameter	Units	Spec. Low	Spec. High	Result	Pass/Fail
Laboratory Temperature	°C	20.6	22.2	21.4	Pass
Laboratory Humidity	%	10	70	32	Pass
Pendulum Velocity	m/s	6.89	7.13	6.92	Pass
Pendulum Deceleration at 10 ms	g	22.5	27.5	25.0	Pass
Pendulum Deceleration at 20 ms	g	17.6	22.6	20.8	Pass
Pendulum Deceleration at 30 ms	g	12.5	18.5	14.9	Pass
Peak Pendulum Decel. after 30 ms	g	0.0	29.0	14.9	Pass
Deceleration Decay to Cross 5 g	ms	34.0	42.0	39.0	Pass
"D" Plane Rotation peak	deg	64.0	78.0	73.6	Pass
	ms	57.0	64.0	58.5	Pass
"D" Plane Rotation Decay To Zero	ms	113.0	128.0	119.0	Pass
Moment About Occipital Condyle	Nm	88.1	108.5	96.3	Pass
	ms	47.0	58.0	52.5	Pass
Moment Decay, Peak to Zero	ms	97.0	107.0	97.8	Pass
Overall Test Results					Pass

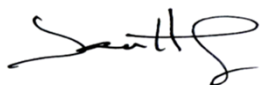

Technician: 
J. Hernandez

Approved By: 
P. Puzzuto

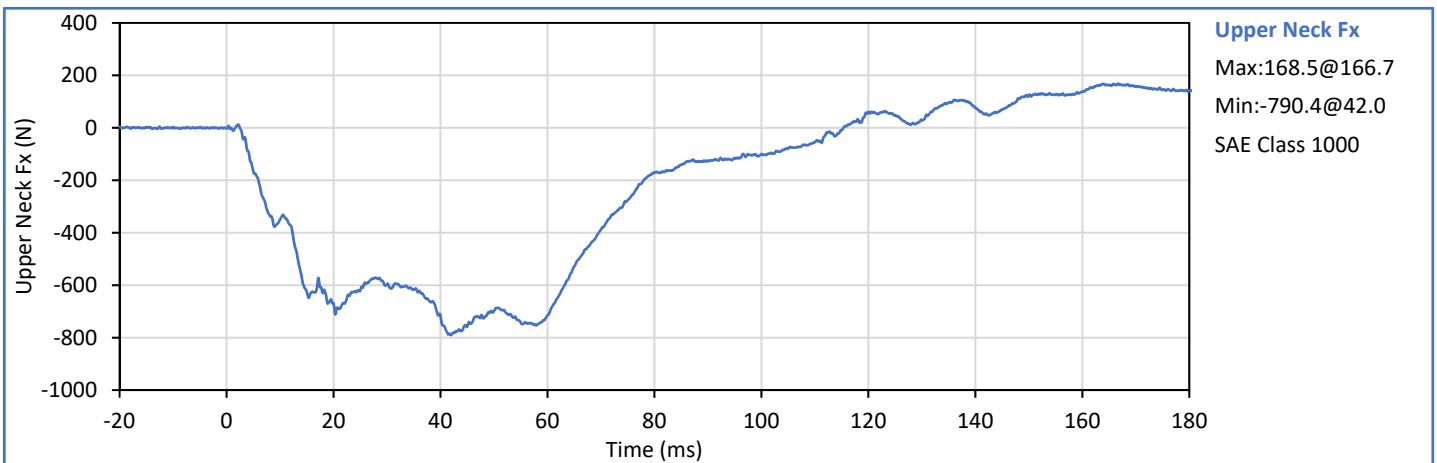
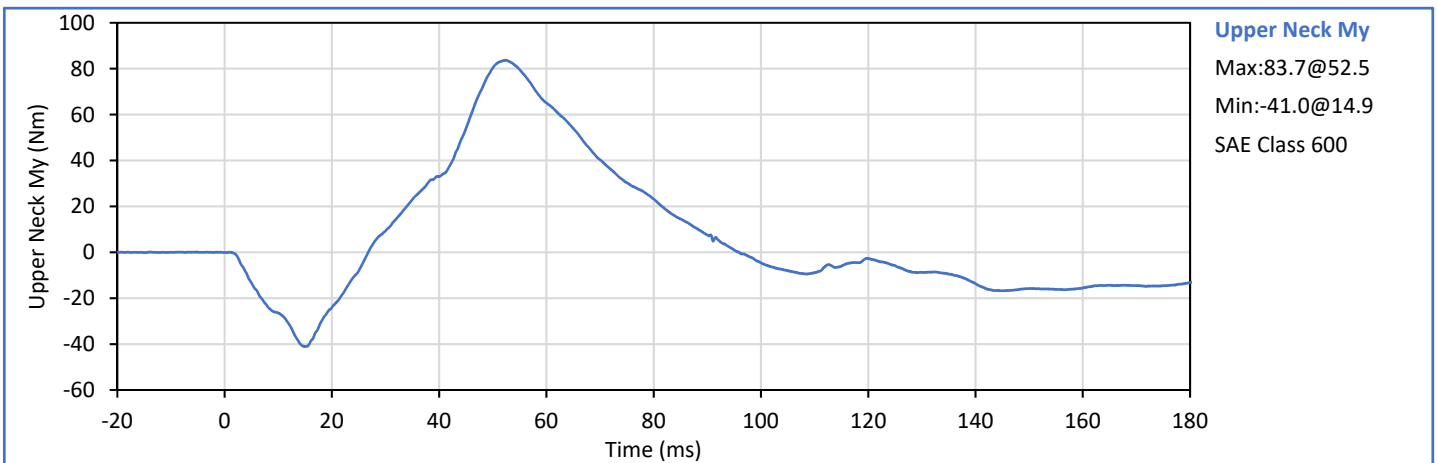
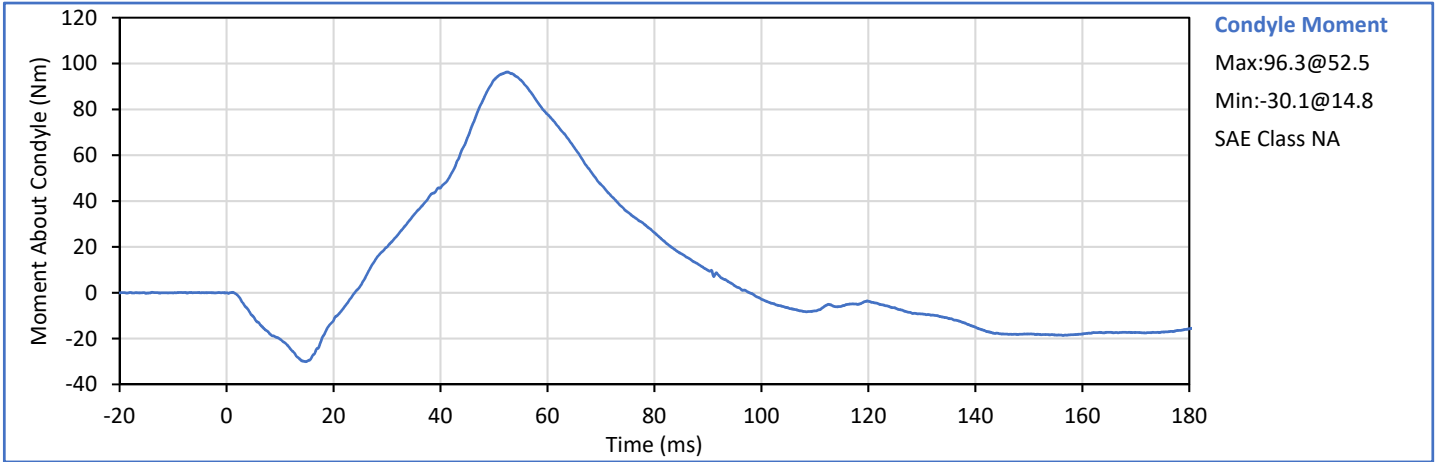

Tested Parameter	Units	Spec. Low	Spec. High	Result	Pass/Fail
Laboratory Temperature	°C	20.6	22.2	21.4	Pass
Laboratory Humidity	%	10	70	32	Pass
Pendulum Velocity	m/s	5.94	6.19	6.00	Pass
Pendulum Deceleration at 10 ms	g	17.2	21.2	19.0	Pass
Pendulum Deceleration at 20 ms	g	14.0	19.0	16.0	Pass
Pendulum Deceleration at 30 ms	g	11.0	16.0	11.8	Pass
Peak Pendulum Decel. after 30 ms	g	0.0	22.0	11.8	Pass
Deceleration Decay to Cross 5 g	ms	38.0	46.0	44.7	Pass
"D" Plane Rotation peak	deg	81.0	106.0	98.4	Pass
	ms	72.0	82.0	78.8	Pass
"D" Plane Rotation Decay To Zero	ms	147.0	174.0	159.7	Pass
Moment About Occipital Condyle	Nm	-79.9	-52.9	-69.1	Pass
	ms	65.0	79.0	72.5	Pass
Moment Decay, Peak to Zero	ms	120.0	148.0	141.9	Pass
Overall Test Results					Pass

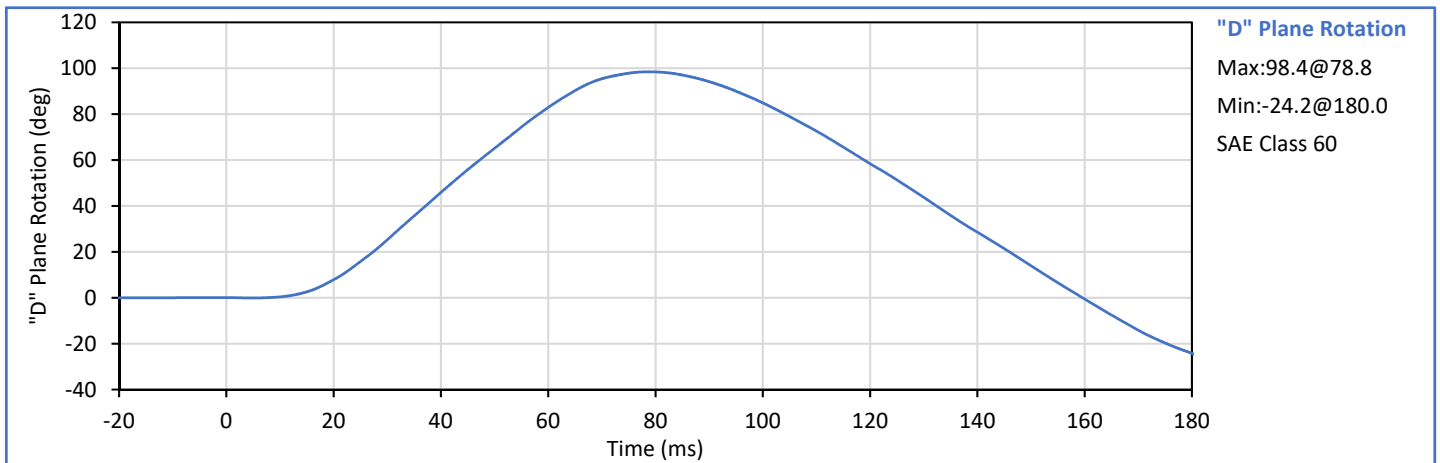
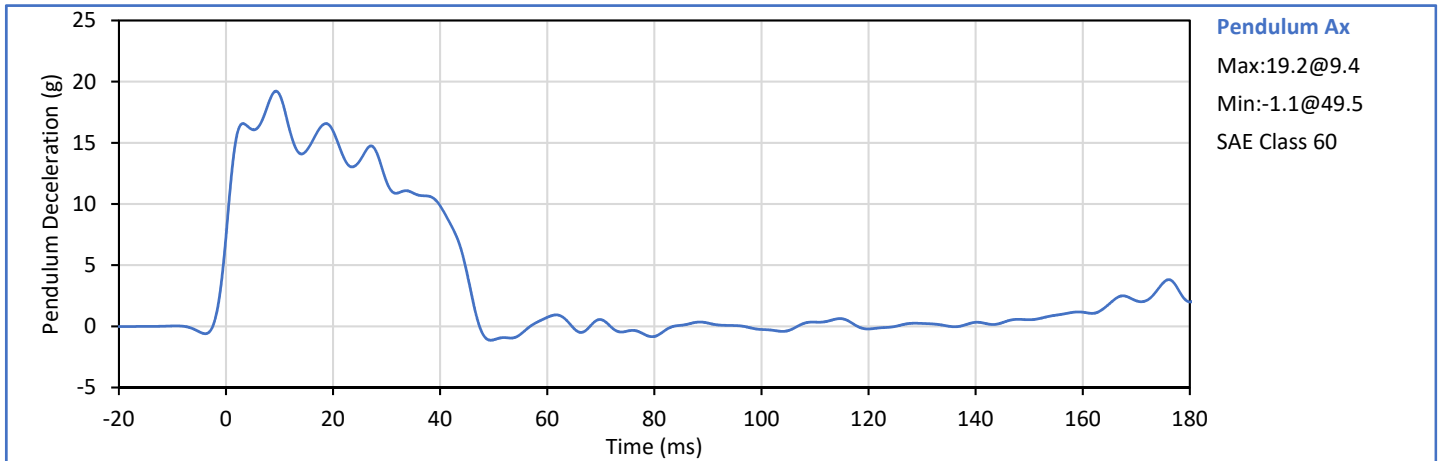

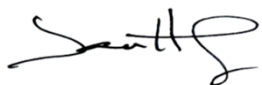
Technician: 
J. Hernandez

Approved By: 
P. Puzzuto

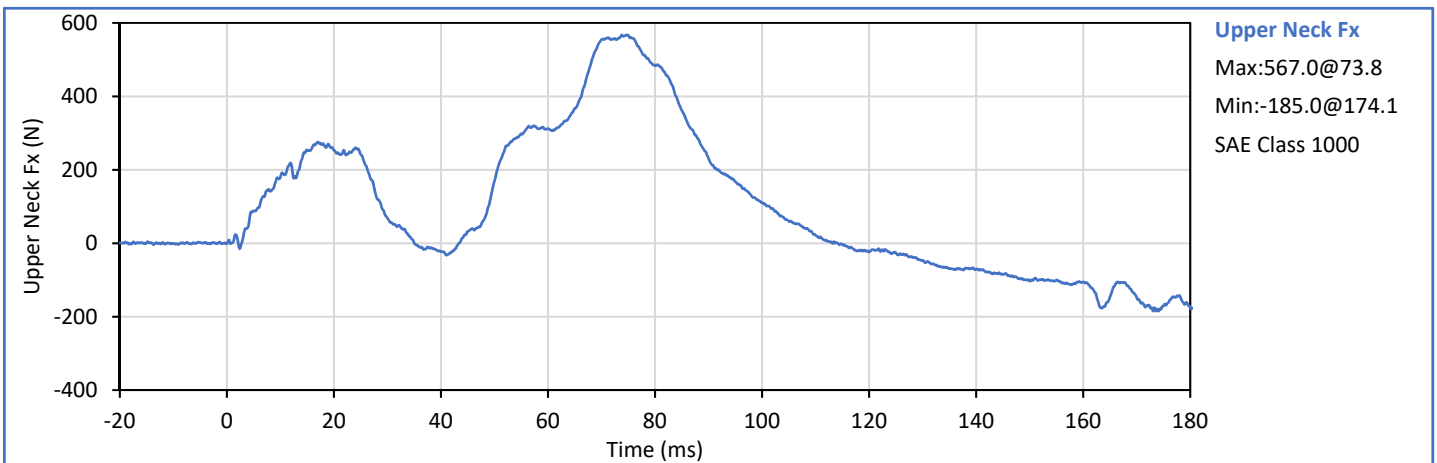
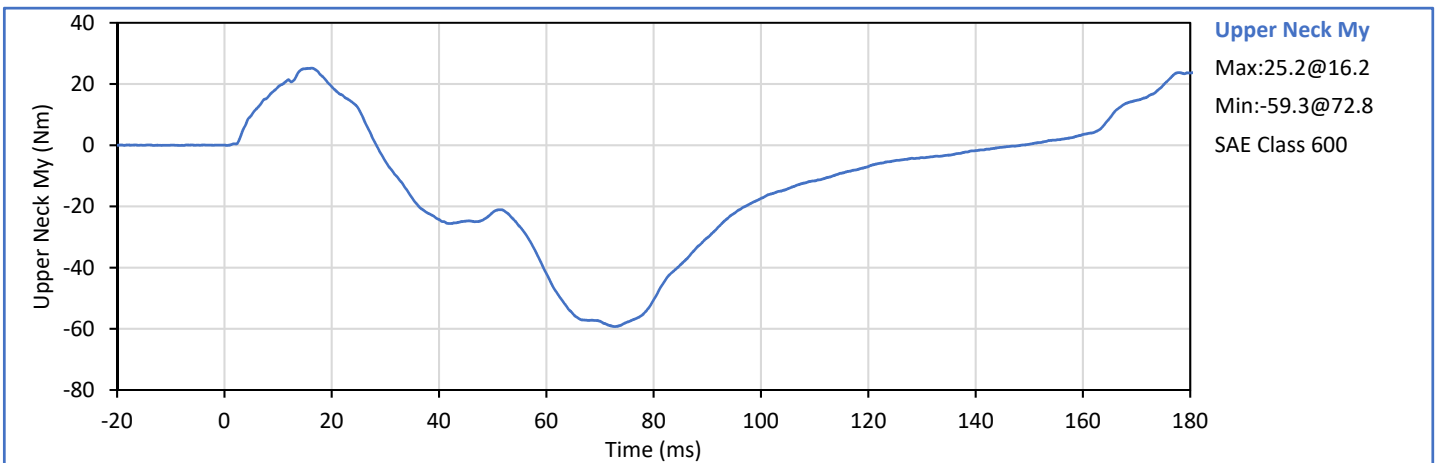
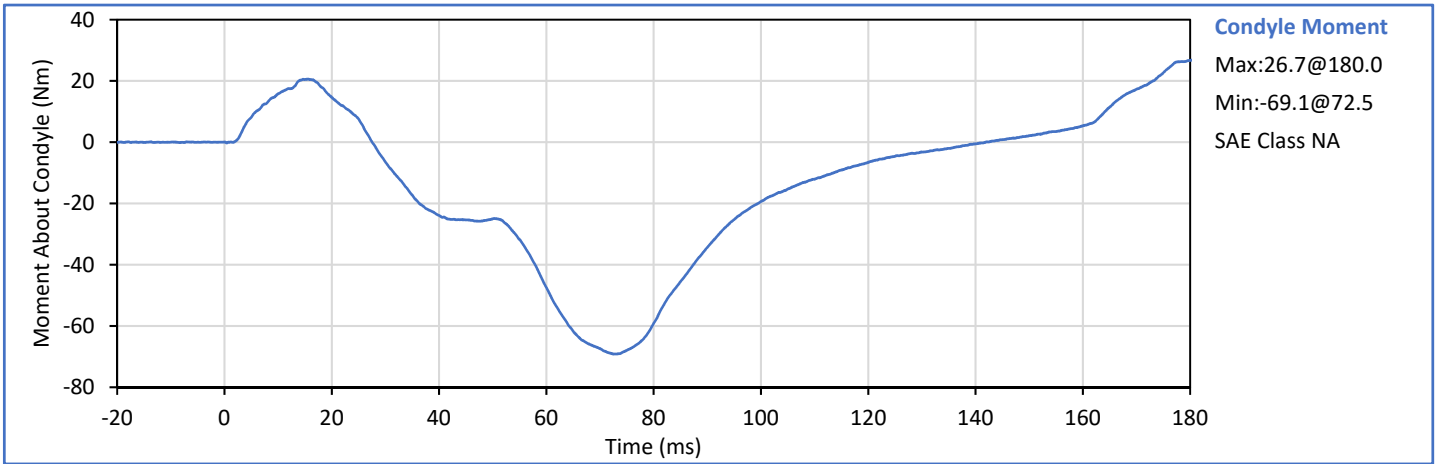

Tested Parameter	Units	Spec. Low	Spec. High	Result	Pass/Fail
Laboratory Temperature	°C	20.6	22.2	21.4	Pass
Laboratory Humidity	%	10	70	26	Pass
Probe Velocity	m/s	6.58	6.82	6.76	Pass
Peak Chest Deflection	cm	6.35	7.26	6.71	Pass
Peak Probe Force	kN	5.159	5.893	5.791	Pass
Internal Hysterisis	%	69.0	85.0	72.6	Pass
Overall Test Results					Pass

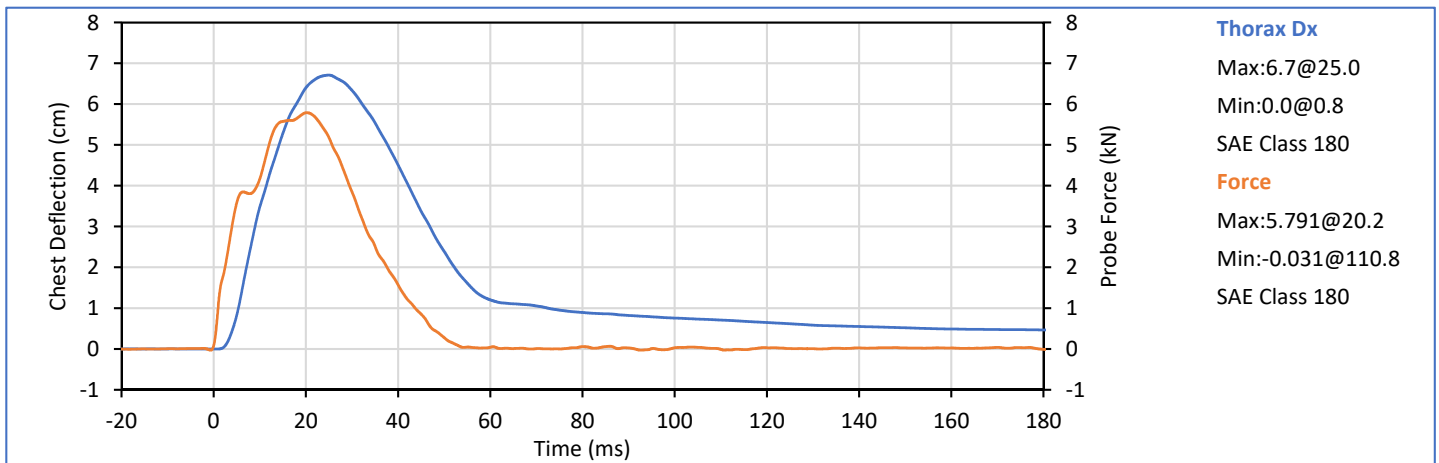
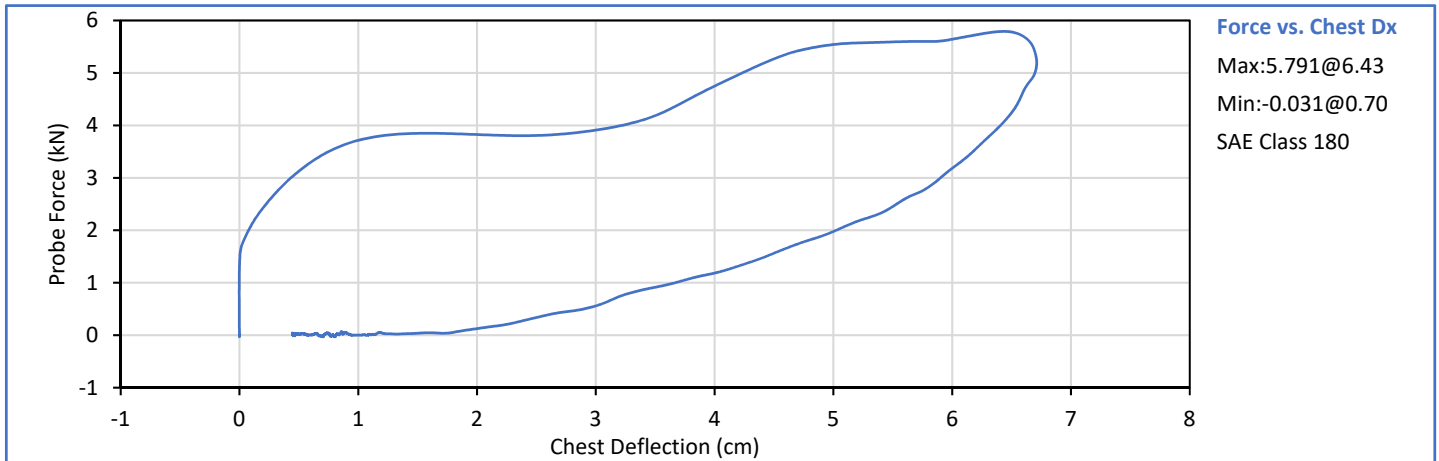

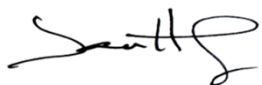

Technician: 
 J. Hernandez

Approved By: 
 P. Puzzuto

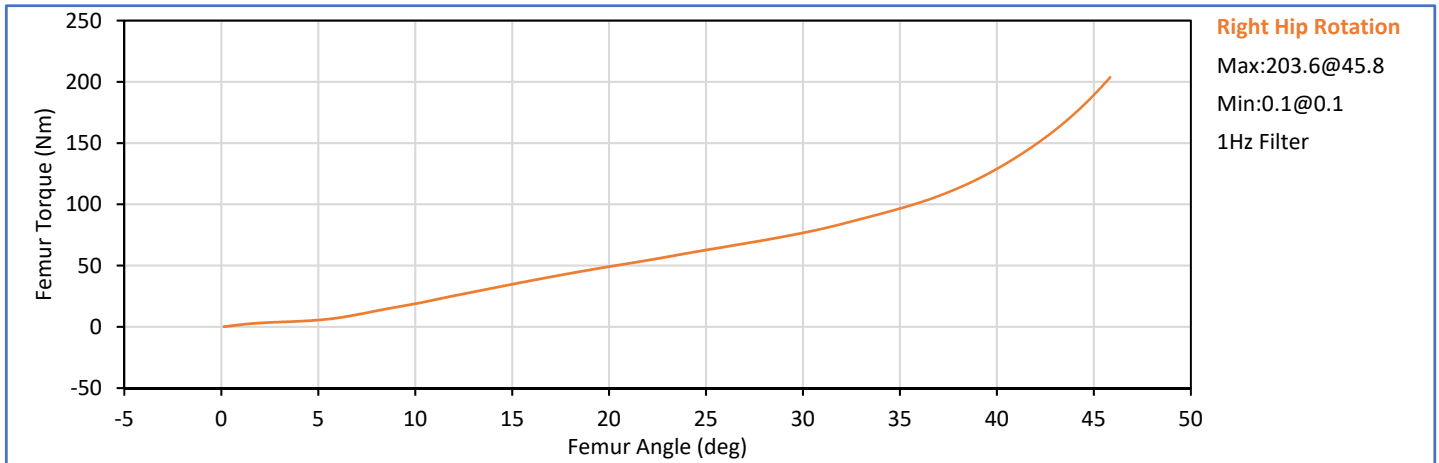
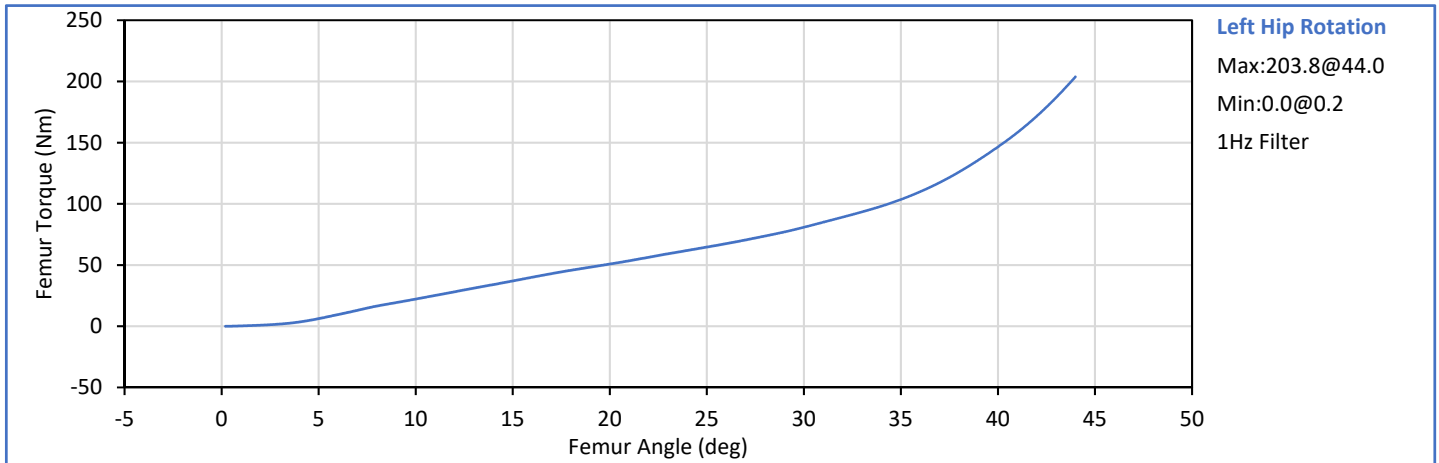
	Tested Parameter	Units	Spec. Low	Spec. High	Result	Pass/Fail
	Laboratory Temperature	°C	18.9	25.6	21.4	Pass
	Laboratory Humidity	%	10	70	32	Pass
Left Hip	Left Hip Rotation Rate	deg/s	5.0	10.0	5.7	Pass
	Left Femur Torque at 30°	Nm	0.0	95.0	81.0	Pass
	Left Hip Rotation at 203 Nm	deg	40.0	50.0	43.9	Pass
Right Hip	Right Hip Rotation Rate	deg/s	5.0	10.0	5.8	Pass
	Right Femur Torque at 30°	Nm	0.0	95.0	76.8	Pass
	Right Hip Rotation at 203 Nm	deg	40.0	50.0	45.8	Pass
Overall Test Results						Pass

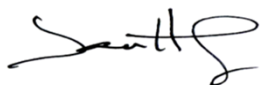



Technician: 
J. Hernandez

Approved By: 
P. Puzzuto

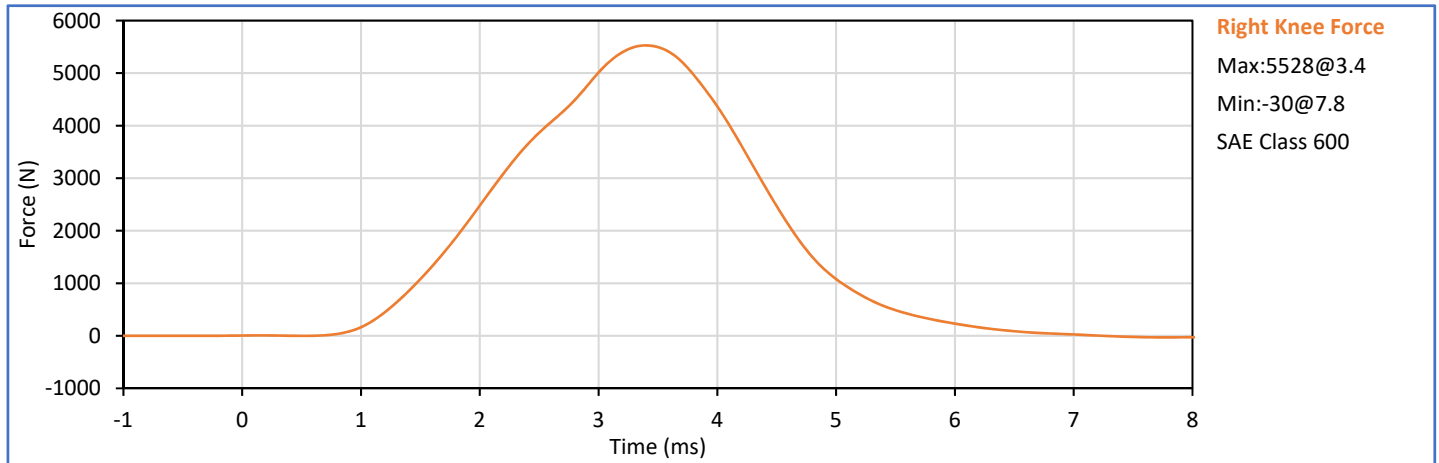
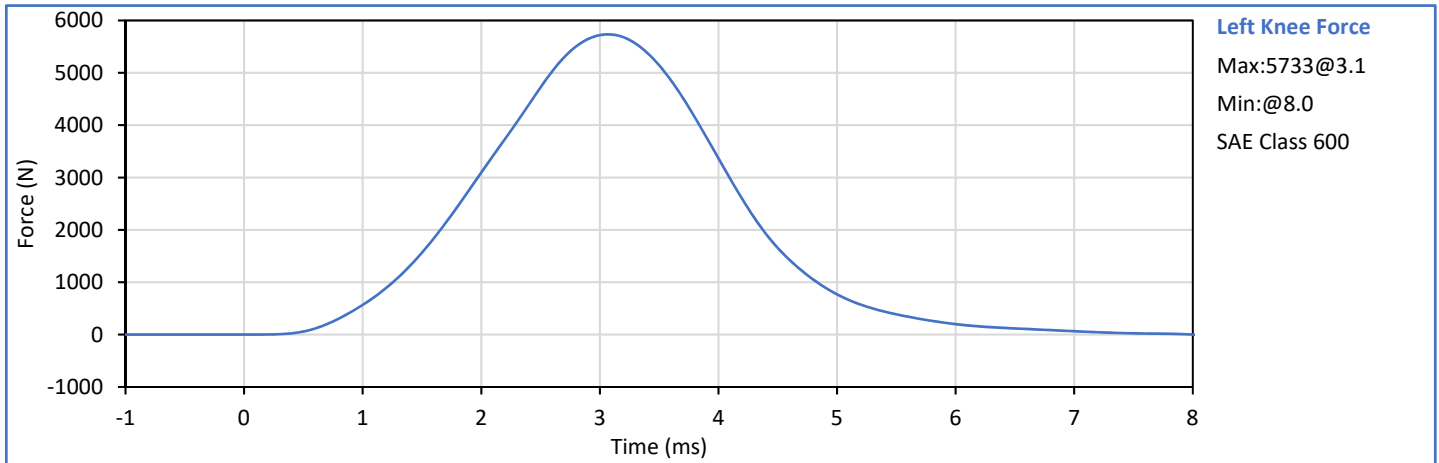
	Tested Parameter	Units	Spec. Low	Spec. High	Result	Pass/Fail
	Laboratory Temperature	°C	18.9	25.6	21.2	Pass
	Laboratory Humidity	%	10	70	21	Pass
Left	Probe Velocity	m/s	2.070	2.130	2.115	Pass
Knee	Peak Resistive Force	N	4715	5782	5733	Pass
Right	Probe Velocity	m/s	2.070	2.130	2.116	Pass
Knee	Peak Resistive Force	N	4715	5782	5528	Pass
					Overall Test Results	Pass

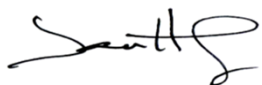

Technician: 
J. Hernandez

Approved By: 
P. Puzzuto

APPENDIX C
Pre-Test ATD Configuration And Performance Verification Data
Hybrid III 5th Percentile Female ATD
S/N: 141

Dummy Item	Inspect for	Comments	Damage	Okay
Entire ATD	Perform general cleaning			✓
Outer Skin	Gashes, rips, cracks			✓
Head	Ballast secure			✓
	General appearance			✓
Neck bracket	Upper neck firmly attached to lower bracket			✓
Neck	Broken or cracked rubber			✓
	Looseness at the condyle joint			✓
Nodding block	Cracked or out of position			✓
Lumbar Spine	Broken or cracked rubber			✓
Ribs	Broken or bent ribs			✓
	Broken or bent rib supports			✓
	Damping material separated or cracked			✓
	Rubber bumpers in place			✓
Chest Displ. Assembly	Bent shaft			✓
	Slider arm riding in track			✓
Sensors	Check cables for cuts, tears			✓
	Check for damaged insulation			✓
Accelerometer Mounting	Head mounting secure			✓
	Chest mounting secure			✓
Knees	Skin condition			✓
	Insert (do not remove)			✓
	Casting			✓
Limbs	Normal movement and adjustment			✓
Knee Sliders	Wires intact			✓
	Rubber returned to "resting" position			✓
Pelvis	Broken			✓
Other	Describe below as needed			✓

Describe any repairs or replacement of parts or other findings:

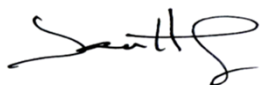
Technician: 
J. Hernandez

Approved By: 
P. Puzzuto

Tested Parameter	Units	Spec. Low	Spec. High	Result	Pass/Fail
Laboratory Temperature	°C	20.6	22.2	21.1	Pass
Laboratory Relative Humidity	%	10	70	22	Pass
A - Total sitting height	mm	775	800	788	Pass
B - Shoulder pivot height	mm	432	457	453	Pass
C - 'H' point height	mm	81	86	86	Pass
D - 'H' point location from backline	mm	145	150	148	Pass
E - Shoulder pivot from backline	mm	69	84	78	Pass
F - Thigh clearance	mm	119	135	128	Pass
G - Back of elbow to wrist pivot	mm	244	259	254	Pass
H - Head back to backline	mm	41	46	43	Pass
I - Shoulder to elbow length	mm	277	297	287	Pass
J - Elbow rest height	mm	183	203	197	Pass
K - Buttock to knee length	mm	521	546	531	Pass
L - Popliteal length	mm	356	376	367	Pass
M - Knee pivot height	mm	394	419	407	Pass
N - Buttock popliteal length	mm	414	439	428	Pass
O - Chest depth without jacket	mm	175	191	183	Pass
P - Foot length	mm	219	234	231	Pass
R - Buttock to Knee Pivot Length	mm	457	483	473	Pass
S - Head Breadth	mm	137	147	144	Pass
T - Head Depth	mm	178	188	184	Pass
U - Hip Breadth	mm	300	315	308	Pass
V - Shoulder breadth	mm	351	366	360	Pass
W - Foot breadth	mm	79	94	88	Pass
X - Head circum.	mm	528	549	535	Pass
Y - Chest circum. (w/chest jacket)	mm	851	881	868	Pass
Z - Waist circum.	mm	760	790	776	Pass
AA - Location for chest circum.	mm	333	358	339	Pass
BB - Location for waist circum.	mm	160	170	168	Pass
Overall Test Results					Pass

Technician:



J. Hernandez

Approved By:



P. Puzzuto

Tested Parameter	Units	Spec. Low	Spec. High	Result	Pass/Fail
Laboratory Temperature	°C	18.9	25.6	20.8	Pass
Laboratory Humidity	%	10	70	22	Pass
Peak Resultant Acceleration	g	250.0	300.0	279.3	Pass
Peak Lateral Acceleration	g	-15.0	15.0	-3.7	Pass
Oscillations After Main Pulse	%	0.0	10.0	1.3	Pass
Is Acceleration Unimodal?	Yes/No	Yes		Yes	Pass
Overall Test Results					Pass

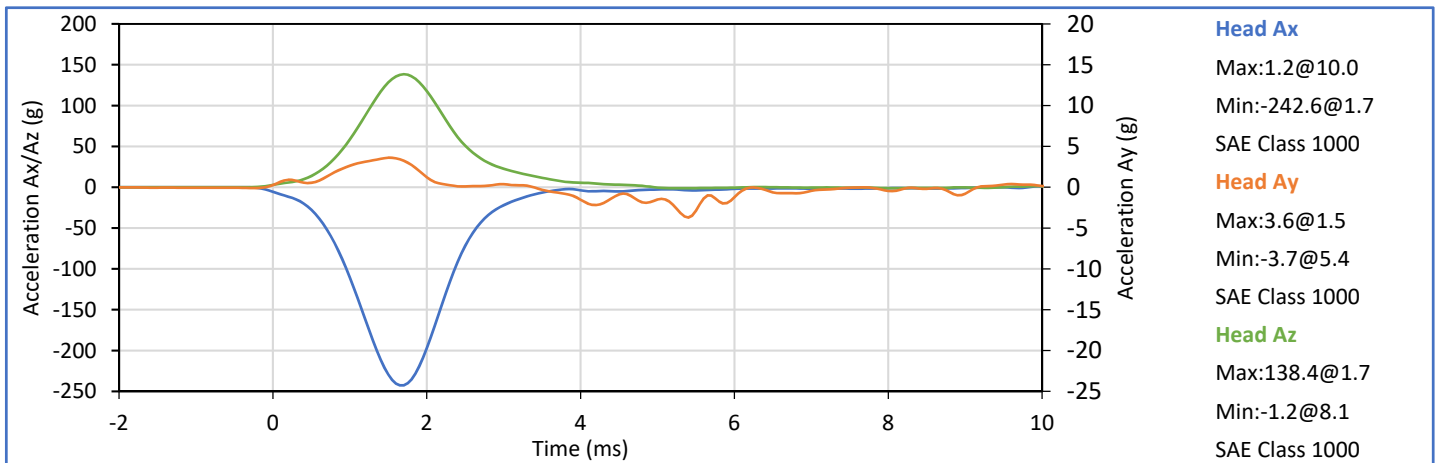
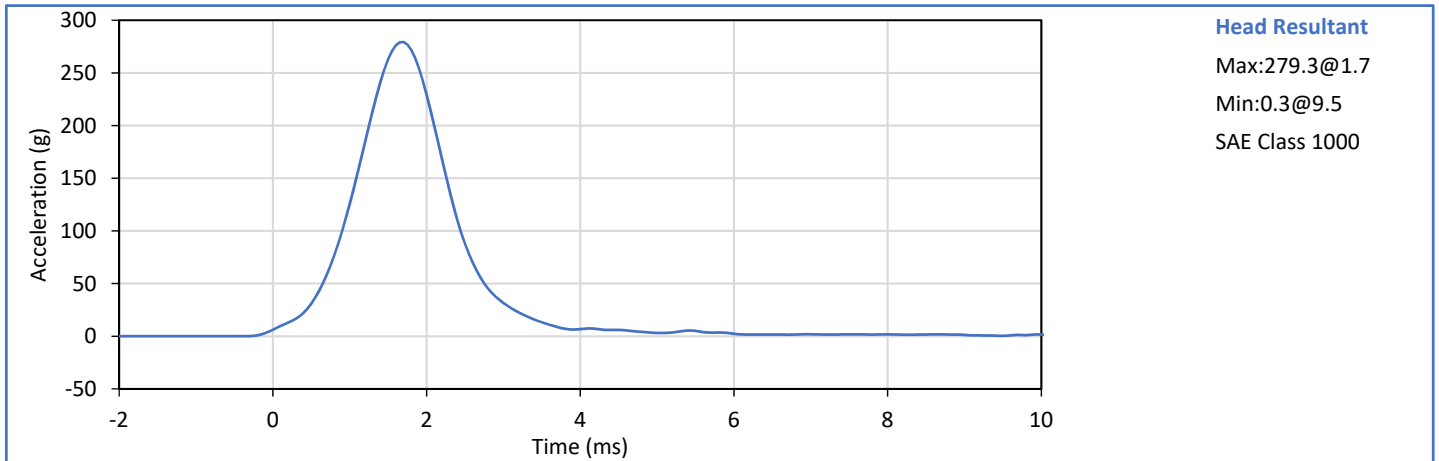

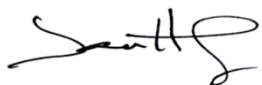

Technician: 
J. Hernandez

Approved By: 
P. Puzzuto

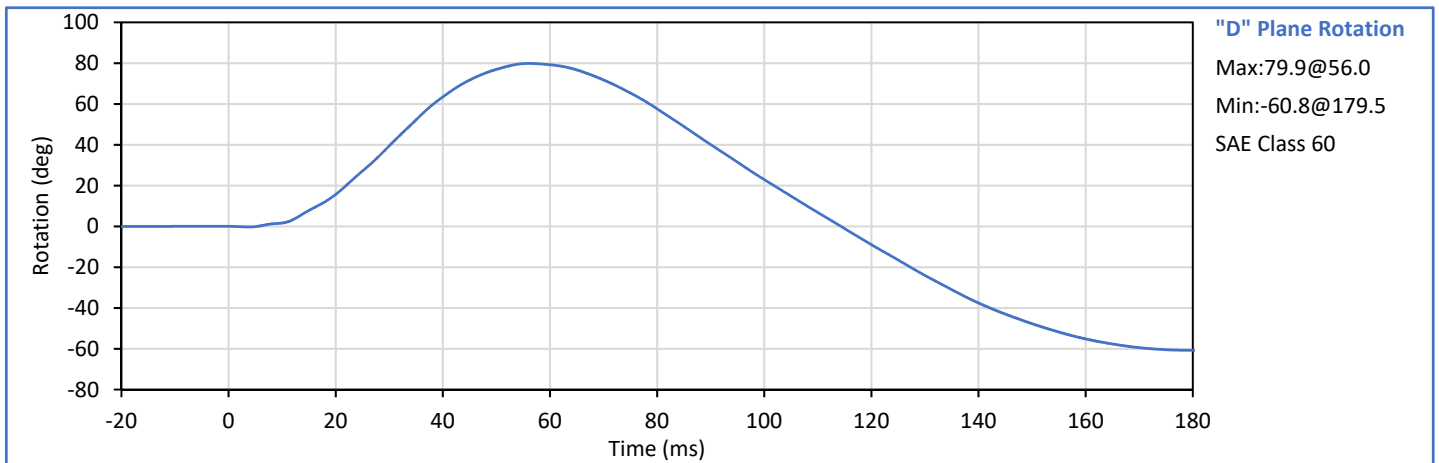
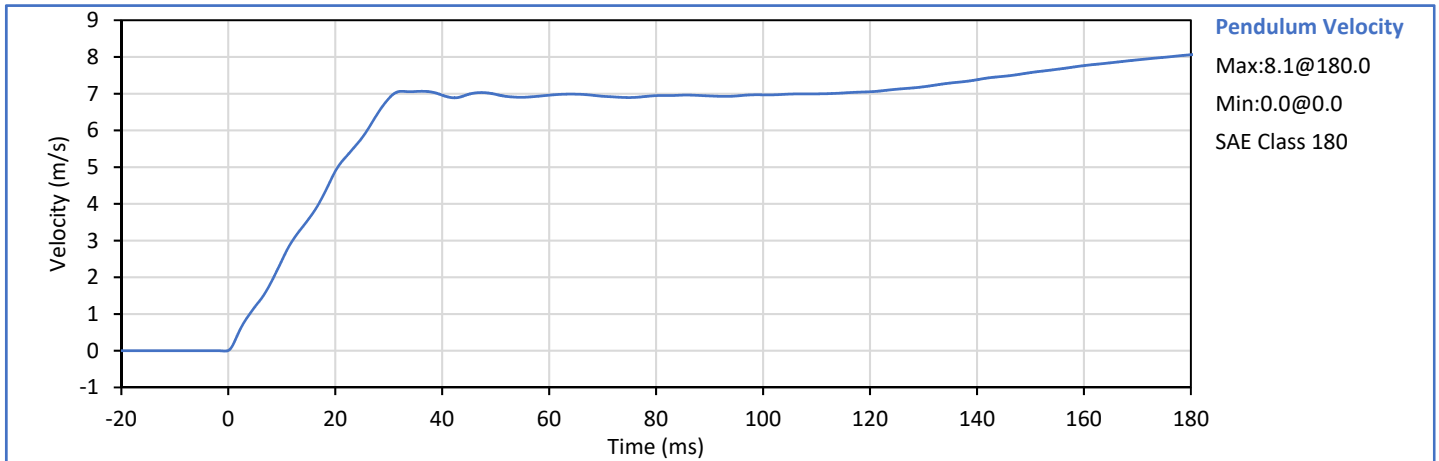
Tested Parameter	Units	Spec. Low	Spec. High	Result	Pass/Fail
Laboratory Temperature	°C	20.6	22.2	20.9	Pass
Laboratory Humidity	%	10	70	37	Pass
Pendulum Velocity	m/s	6.89	7.13	6.90	Pass
Pendulum Velocity at 10 ms	m/s	2.10	2.50	2.45	Pass
Pendulum Velocity at 20 ms	m/s	4.00	5.00	4.88	Pass
Pendulum Velocity at 30 ms	m/s	5.80	7.00	6.87	Pass
Peak "D" Plane Rotation	deg	77.0	91.0	79.9	Pass
Peak Moment in Rotation	Nm	69.0	83.0	74.5	Pass
Positive Moment Decay to 10 Nm	ms	80.0	100.0	83.3	Pass
Overall Test Results					Pass

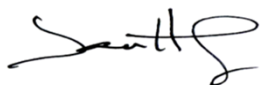

Technician: 
J. Hernandez

Approved By: 
P. Puzzuto

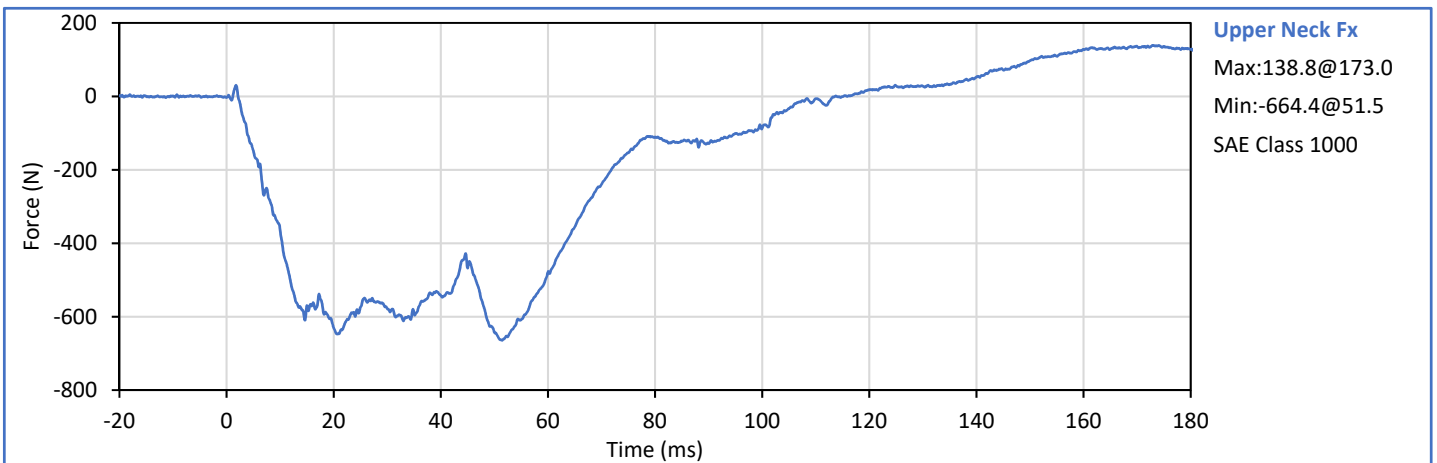
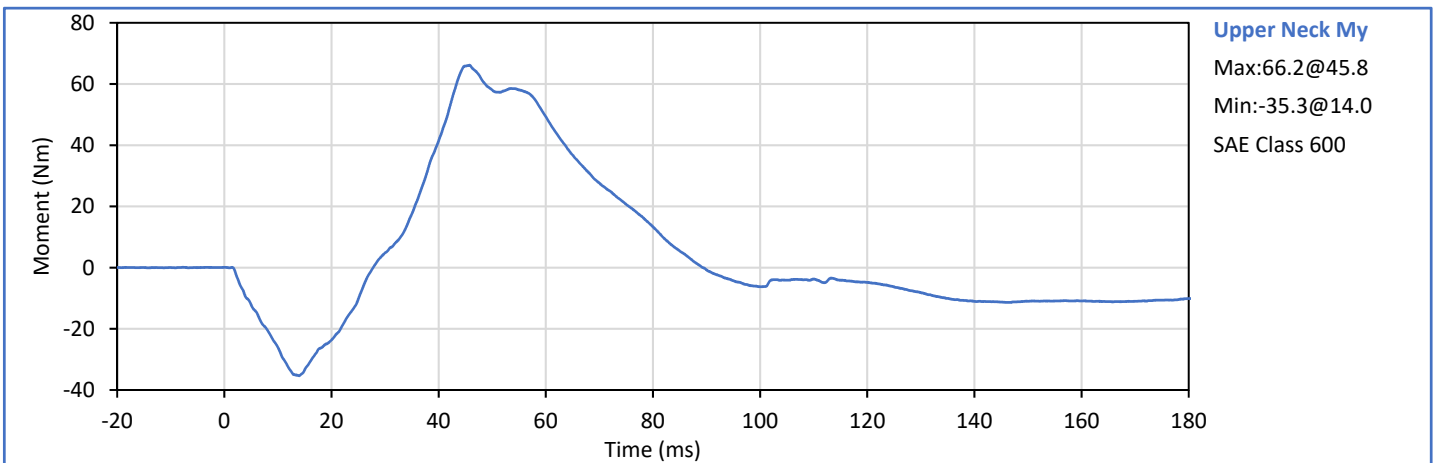
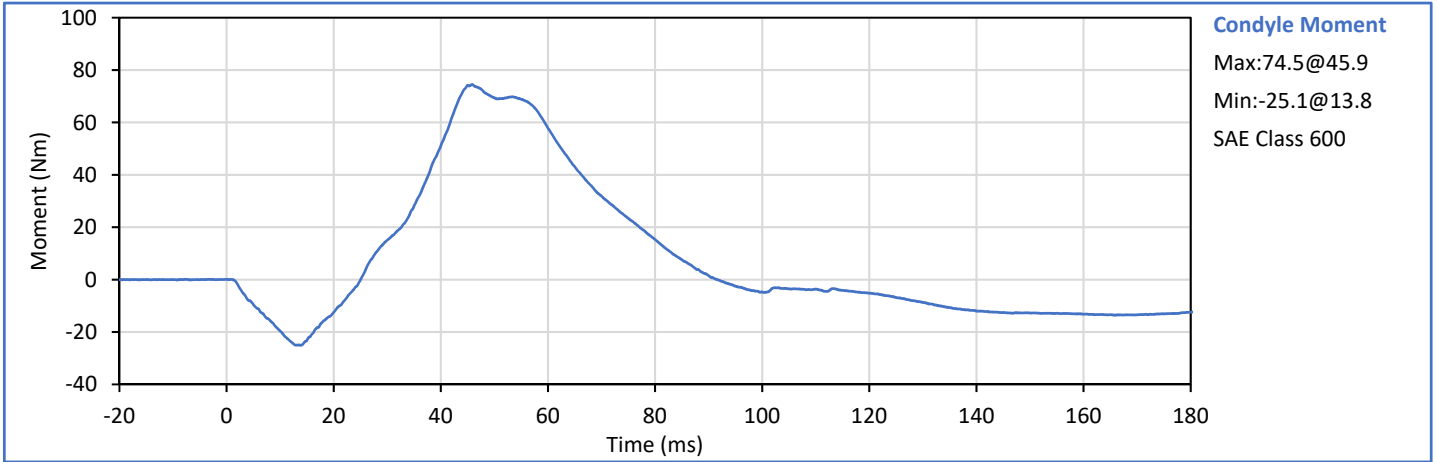

Tested Parameter	Units	Spec. Low	Spec. High	Result	Pass/Fail
Laboratory Temperature	°C	20.6	22.2	20.9	Pass
Laboratory Humidity	%	10	70	37	Pass
Pendulum Velocity	m/s	5.95	6.19	6.10	Pass
Pendulum Velocity at 10 ms	m/s	1.50	1.90	1.56	Pass
Pendulum Velocity at 20 ms	m/s	3.10	3.90	3.23	Pass
Pendulum Velocity at 30 ms	m/s	4.60	5.60	4.72	Pass
Peak "D" Plane Rotation	deg	99.0	114.0	106.8	Pass
Peak Moment in Rotation	Nm	-65.0	-53.0	-58.2	Pass
Negative Moment Decay to -10 Nm	ms	94.0	114.0	110.0	Pass
Overall Test Results					Pass

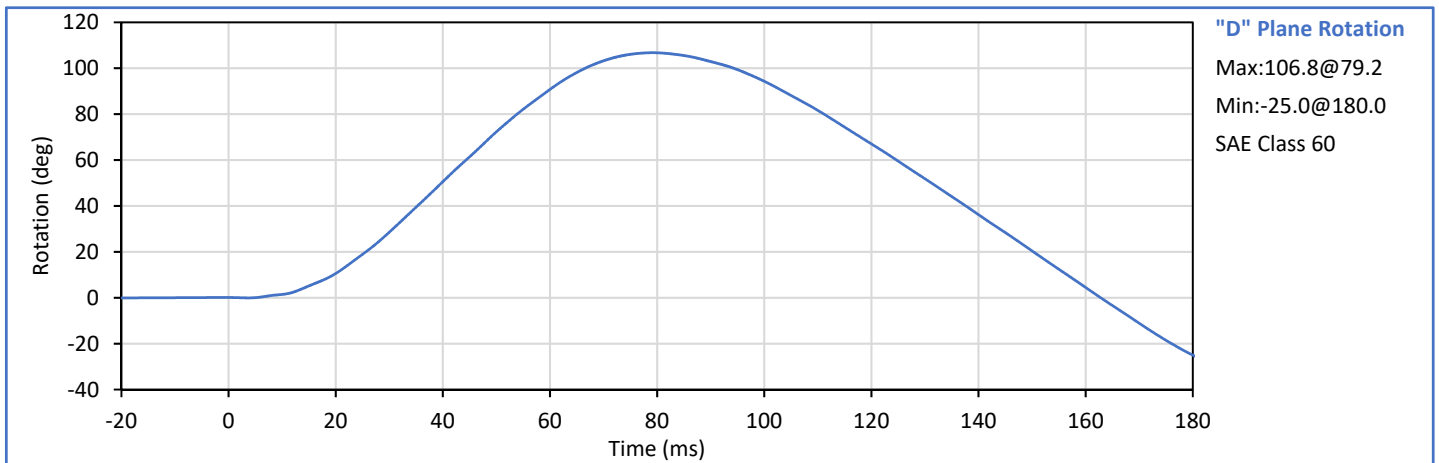
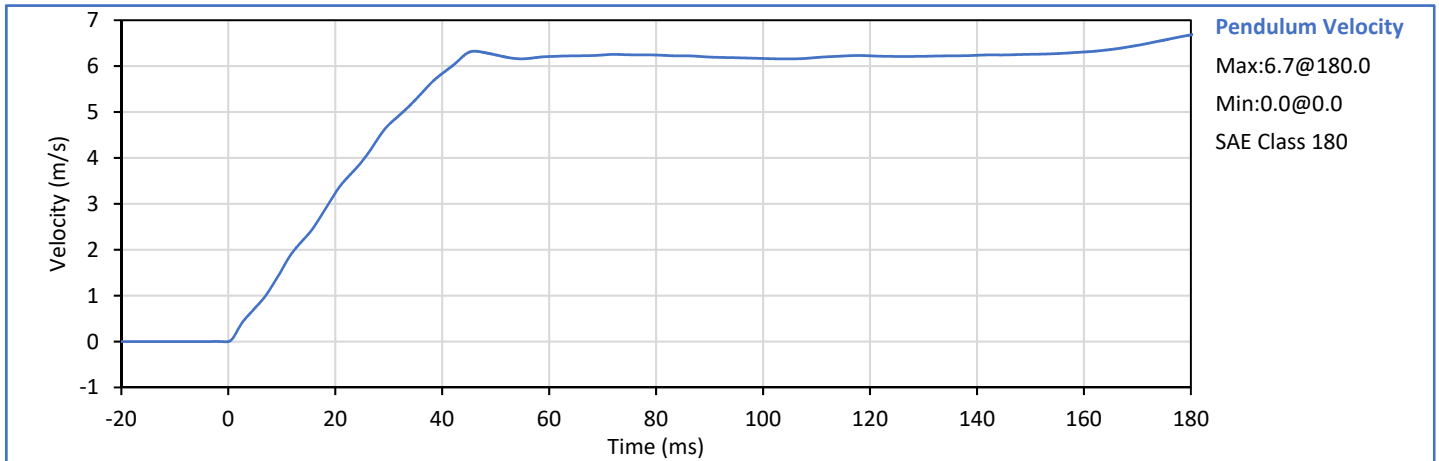

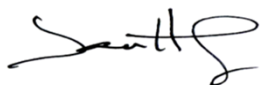
Technician: 
J. Hernandez

Approved By: 
P. Puzzuto

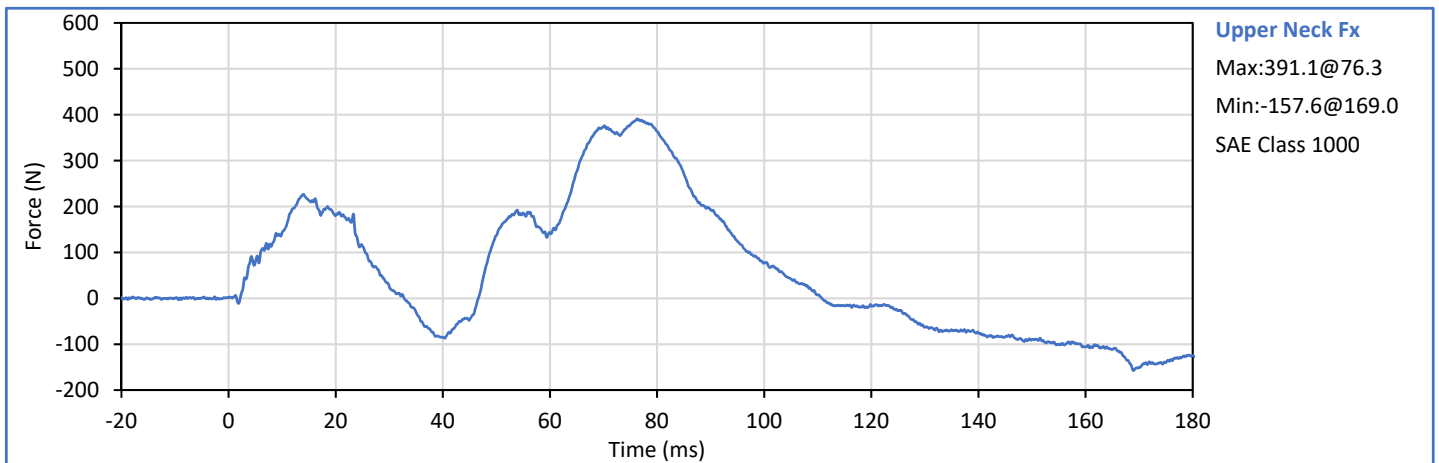
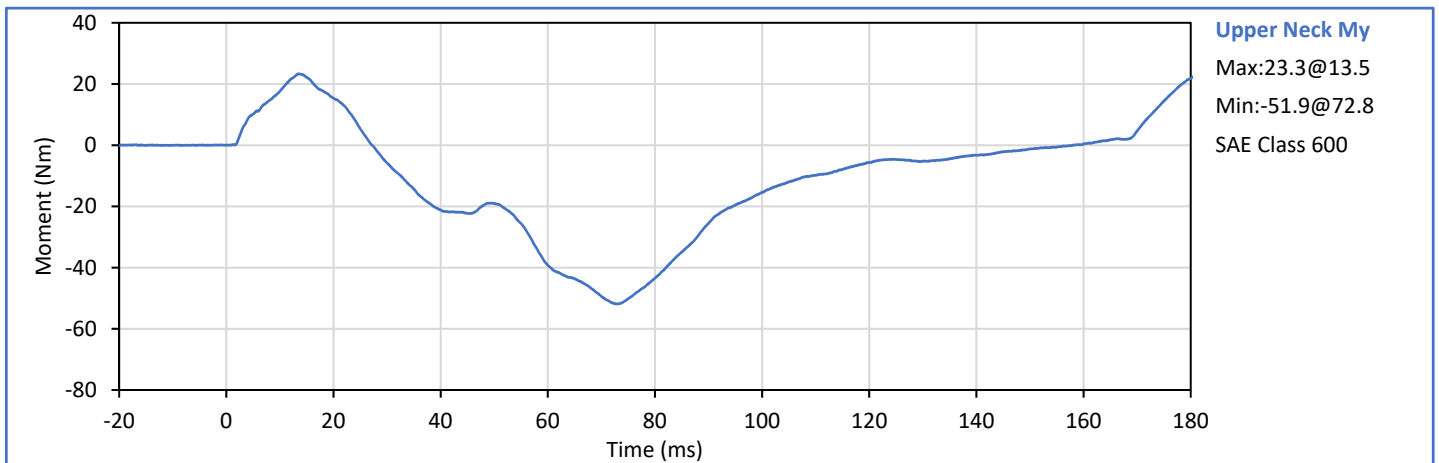
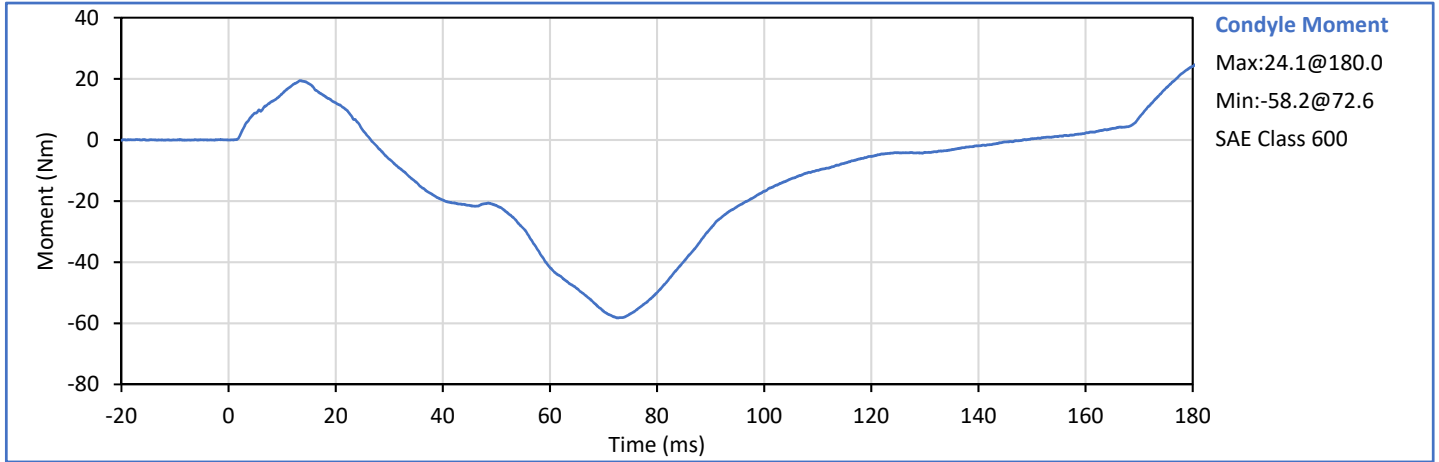

Tested Parameter	Units	Spec. Low	Spec. High	Result	Pass/Fail
Laboratory Temperature	°C	20.6	22.2	21.2	Pass
Laboratory Humidity	%	10	70	33	Pass
Probe Velocity	m/s	6.59	6.83	6.64	Pass
Peak Chest Deflection	mm	50.0	58.0	55.3	Pass
Peak Probe Force, 50 and 58 mm	kN	3.900	4.400	4.241	Pass
Peak Probe Force, 18 and 50 mm	kN	0.000	4.600	4.084	Pass
Internal Hysterisis	%	69.0	85.0	72.7	Pass
Overall Test Results					Pass

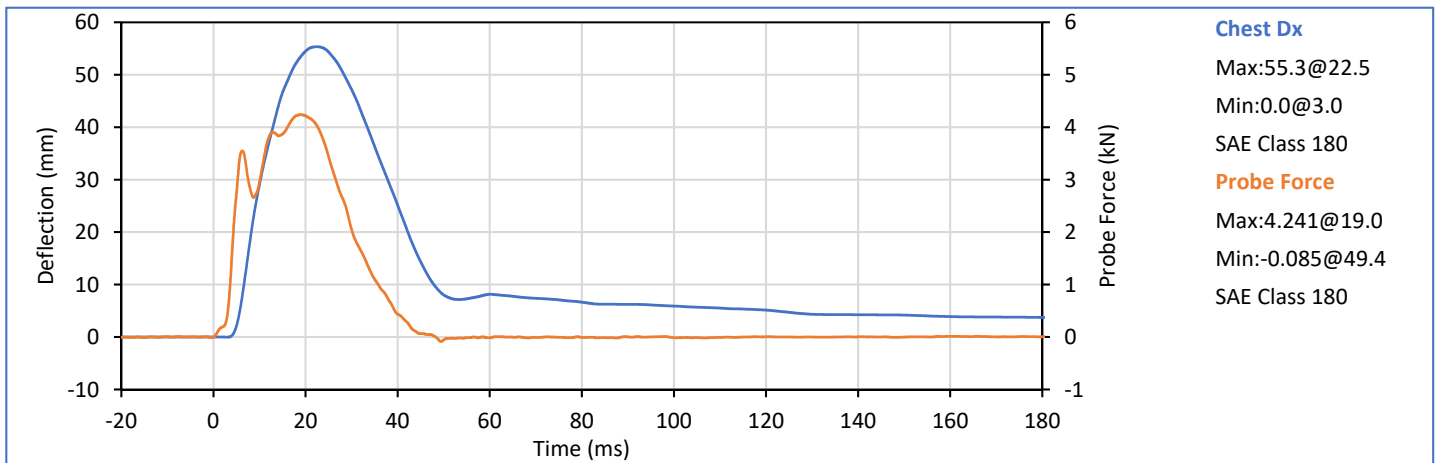
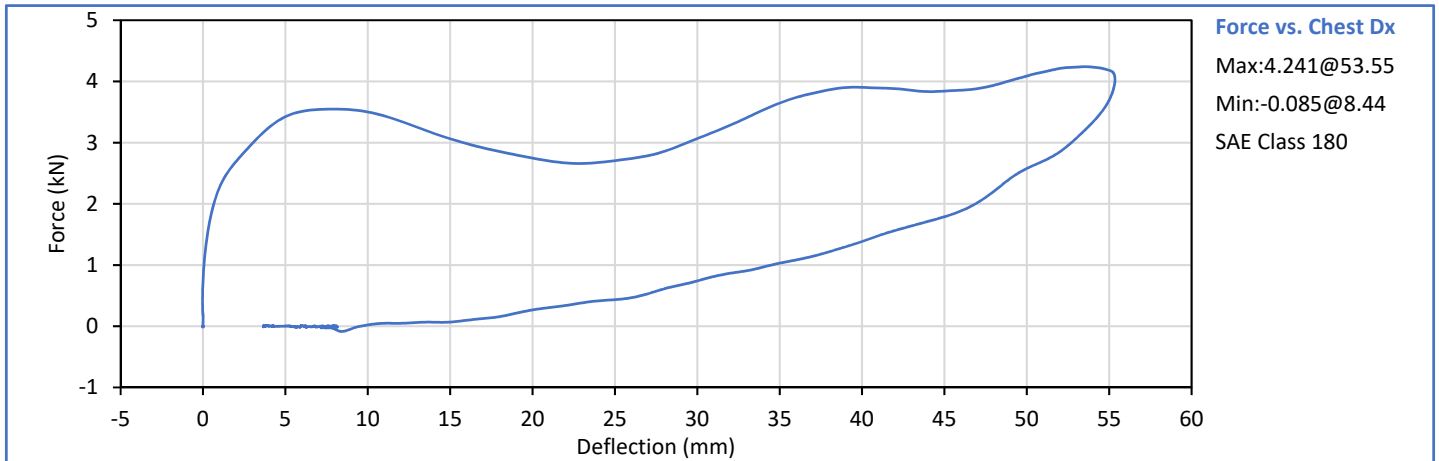

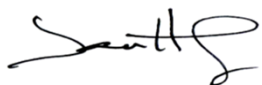

Technician: 
 J. Hernandez

Approved By: 
 P. Puzzuto

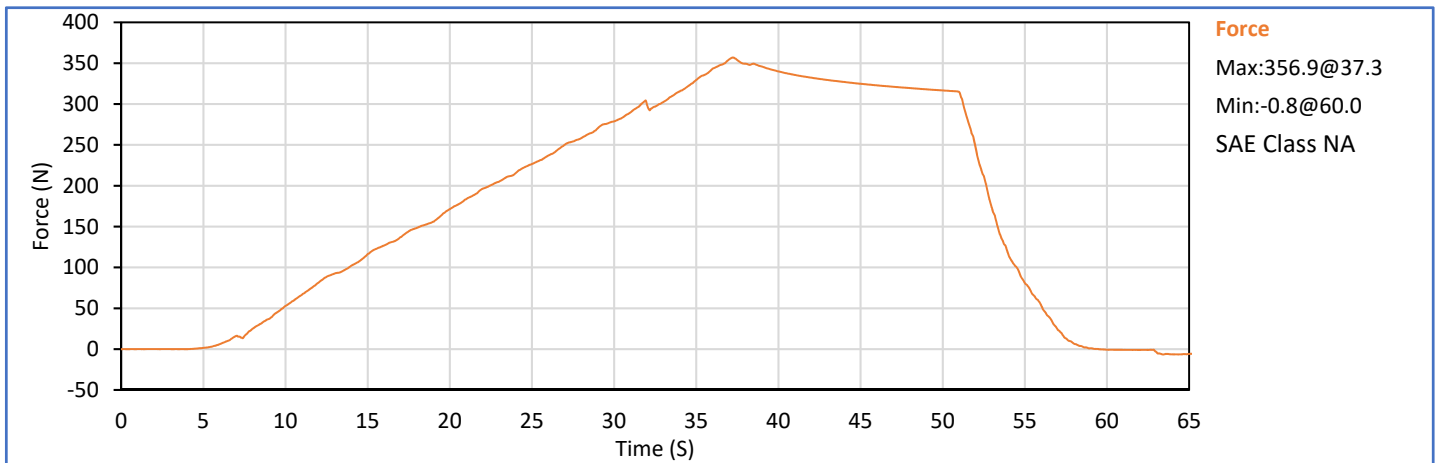
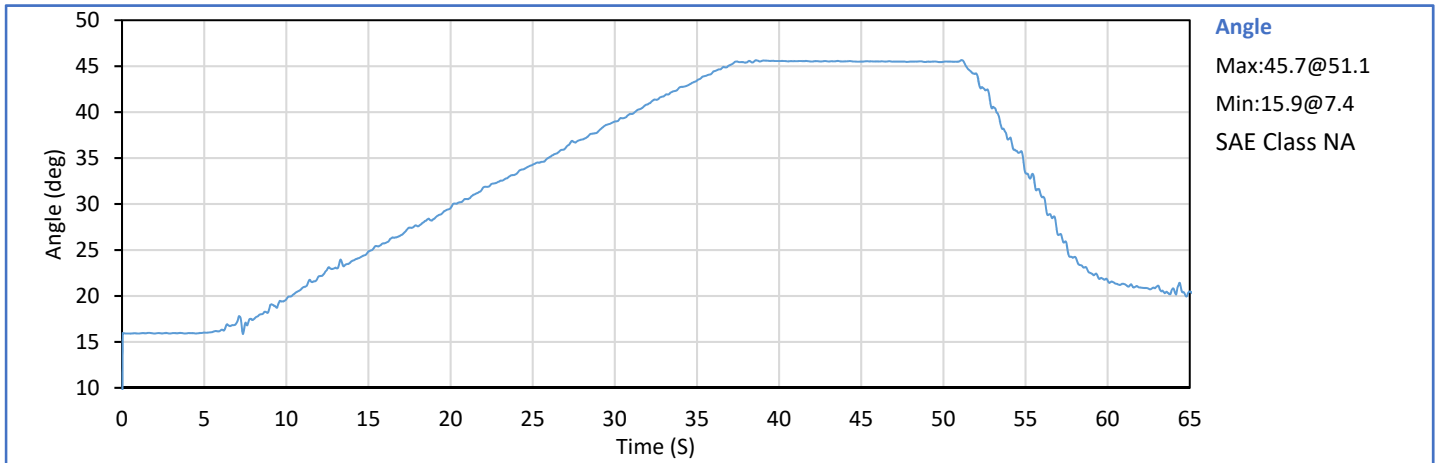
Tested Parameter	Units	Spec. Low	Spec. High	Result	Pass/Fail
Laboratory Temperature	°C	18.9	25.6	21.9	Pass
Laboratory Humidity	%	10	70	32	Pass
Orientation Angle	deg	0.0	20.0	15.1	Pass
Test Initial Angle	deg	11.0	19.0	15.9	Pass
Peak Force at 45° (+/-0.5°)	N	320.0	390.0	352.3	Pass
Torso Flexion Rate	deg/s	0.50	1.50	0.96	Pass
Final Reference Plane Angle	deg	-8.0	8.0	4.1	Pass
Overall Test Results					Pass

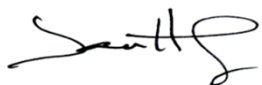



Technician: 
J. Hernandez

Approved By: 
P. Puzzuto

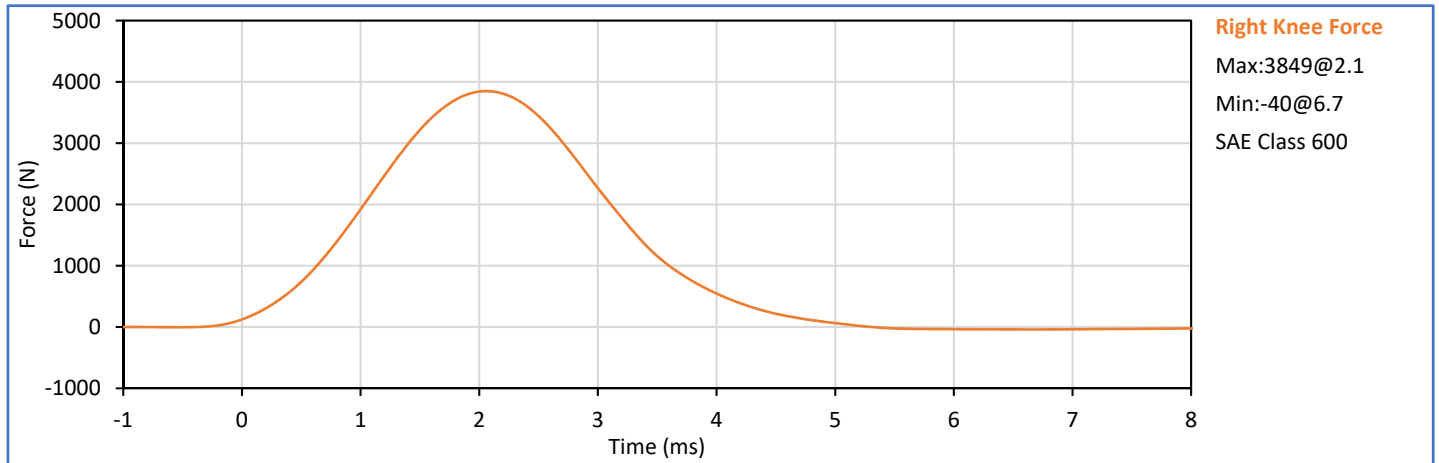
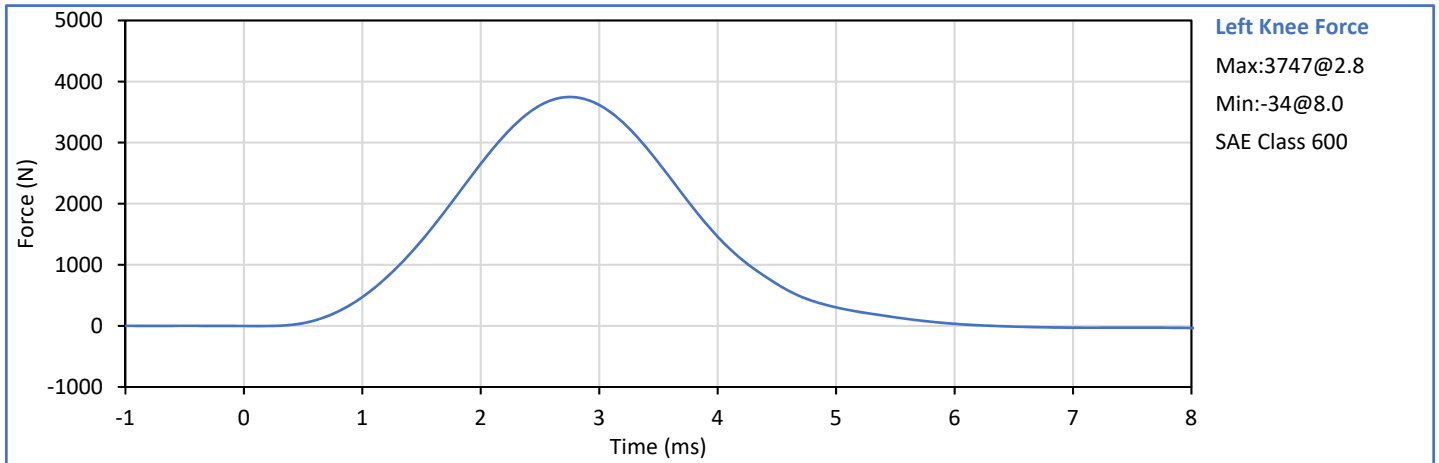
	Tested Parameter	Units	Spec. Low	Spec. High	Result	Pass/Fail
	Laboratory Temperature	°C	18.9	25.6	21.6	Pass
	Laboratory Humidity	%	10	70	34	Pass
Left	Probe Velocity	m/s	2.070	2.130	2.086	Pass
Knee	Peak Resistive Force	N	3450	4060	3747	Pass
Right	Probe Velocity	m/s	2.070	2.130	2.085	Pass
Knee	Peak Resistive Force	N	3450	4060	3849	Pass
Overall Test Results						Pass

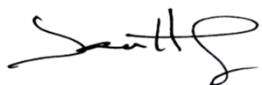

Technician: 
J. Hernandez

Approved By: 
P. Puzzuto

APPENDIX C
Post-Test ATD Configuration And Performance Verification Data
Hybrid III 50th Percentile Male ATD
S/N: 360

ATD Serial No.: 360

Test Date: 2019-03-13

Dummy Item	Inspect for	Comments	Damage	OK
Entire ATD	Perform general cleaning			✓
Outer Skin	Gashes, rips, cracks			✓
Head	Ballast secure			✓
	General appearance			✓
Neck bracket	Upper neck firmly attached to lower bracket			✓
Neck	Broken or cracked rubber			✓
	Looseness at the condyle joint			✓
Nodding block	Cracked or out of position			✓
Lumbar Spine	Broken or cracked rubber			✓
Ribs	Broken or bent ribs			✓
	Broken or bent rib supports			✓
	Damping material separated or cracked			✓
	Rubber bumpers in place			✓
Chest Displ. Assembly	Bent shaft			✓
	Slider arm riding in track			✓
Sensors	Check cables for cuts, tears			✓
	Check for damaged insulation			✓
Accelerometer Mounting	Head mounting secure			✓
	Chest mounting secure			✓
Knees	Skin condition			✓
	Insert (do not remove)			✓
	Casting			✓
Limbs	Normal movement and adjustment			✓
Knee Sliders	Wires intact			✓
	Rubber returned to "resting" position			✓
Pelvis	Broken			✓
Other	Describe below as needed			✓

Describe any repairs or replacement of parts or other findings:

No Problems Found

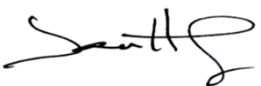
Technician: 
J. Hernandez

Approved By: 
P. Puzzuto

Tested Parameter	Units	Spec. Low	Spec. High	Result	Pass/Fail
Laboratory Temperature	°C	20.6	22.2	21.4	Pass
Laboratory Relative Humidity	%	10	70	26	Pass
A - Total sitting height	mm	879	889	882	Pass
B - Shoulder pivot height	mm	505	521	516	Pass
C - 'H' point height	mm	84	89	87	Pass
D - 'H' point location from backline	mm	135	140	139	Pass
E - Shoulder pivot from backline	mm	84	94	93	Pass
F - Thigh clearance	mm	140	155	150	Pass
G - Back of elbow to wrist pivot	mm	290	305	298	Pass
H - Head back to backline	mm	41	46	44	Pass
I - Shoulder to elbow length	mm	330	345	341	Pass
J - Elbow rest height	mm	190	211	204	Pass
K - Buttock to knee length	mm	579	604	596	Pass
L - Popliteal length	mm	429	455	448	Pass
M - Knee pivot height	mm	485	500	491	Pass
N - Buttock popliteal length	mm	452	477	458	Pass
O - Chest depth without jacket	mm	213	229	224	Pass
P - Foot length	mm	251	267	259	Pass
V - Shoulder breadth	mm	422	437	426	Pass
W - Foot breadth	mm	91	107	97	Pass
Y - Chest circum. (w/chest jacket)	mm	970	1001	982	Pass
Z - Waist circum.	mm	836	866	856	Pass
AA - Location for chest circum.	mm	429	434	430	Pass
BB - Location for waist circum.	mm	226	231	229	Pass
Overall Test Results					Pass

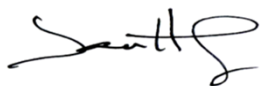
Technician: 
J. Hernandez

Approved By: 
P. Puzzuto

Tested Parameter	Units	Spec. Low	Spec. High	Result	Pass/Fail
Laboratory Temperature	°C	18.9	25.6	21.4	Pass
Laboratory Humidity	%	10	70	25	Pass
Peak Resultant Acceleration	g	225.0	275.0	263.3	Pass
Peak Lateral Acceleration	g	-15.0	15.0	-5.4	Pass
Oscillations After Main Pulse	%	0.0	10.0	2.7	Pass
Is Acceleration Unimodal?	Yes/No	Yes		Yes	Pass
Overall Test Results					Pass

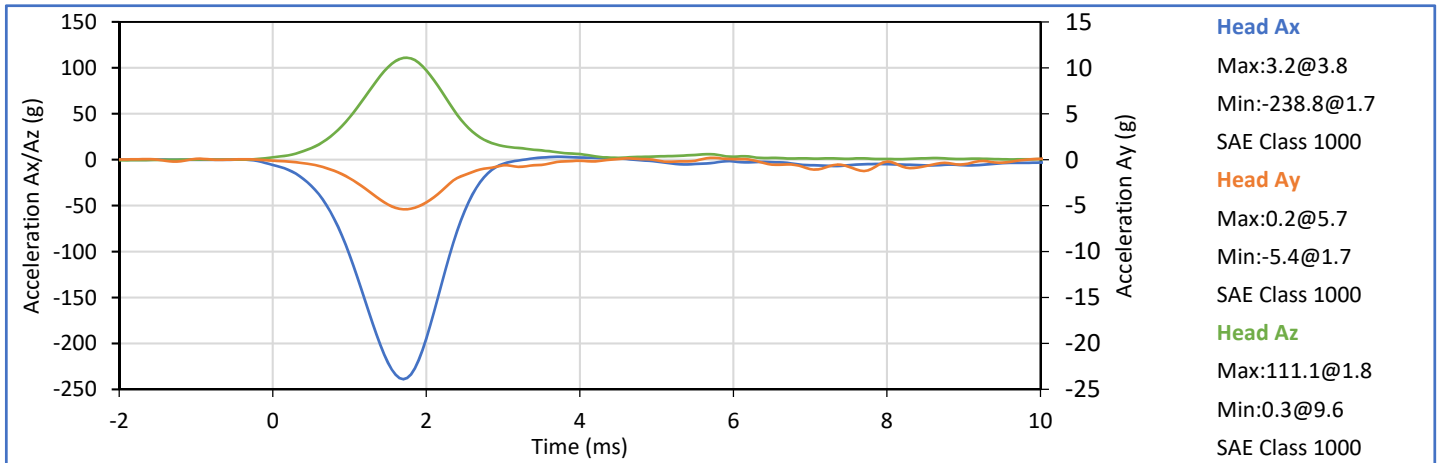
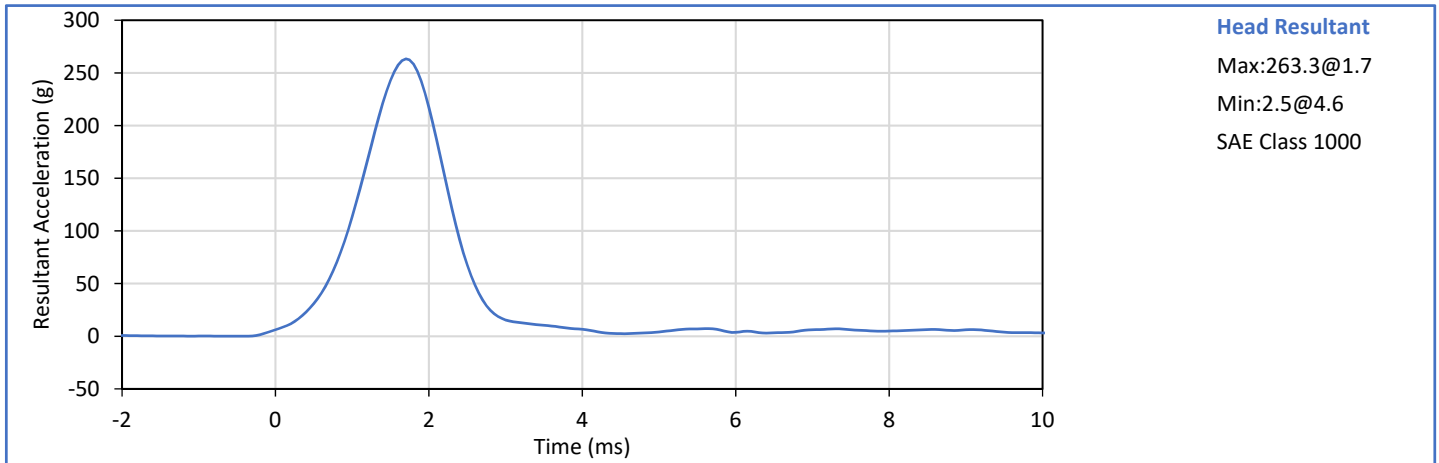

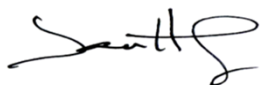

Technician: 
J. Hernandez

Approved By: 
P. Puzzuto

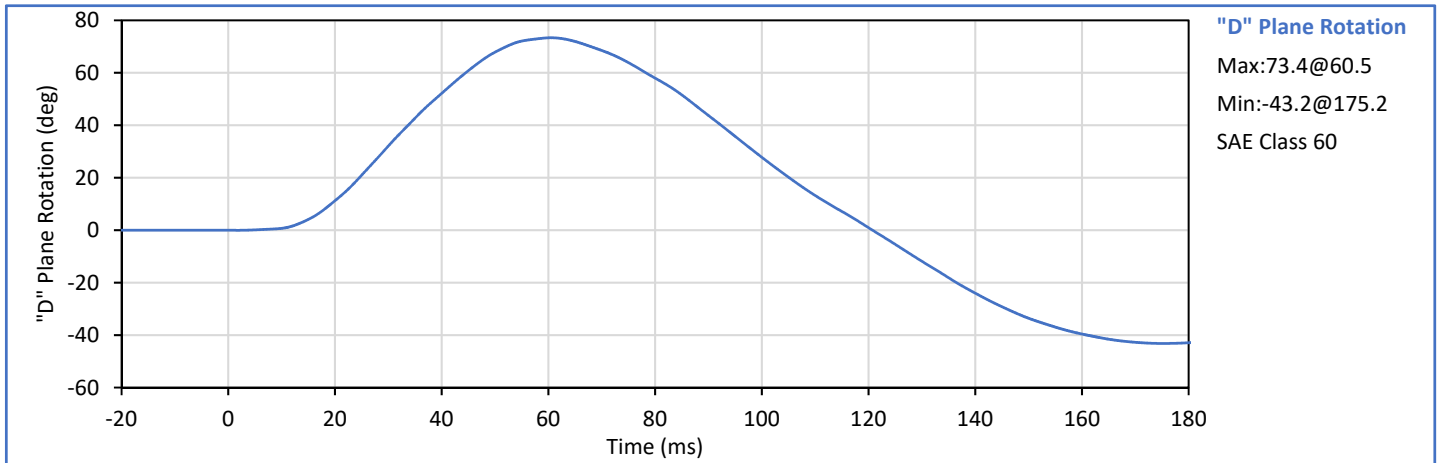
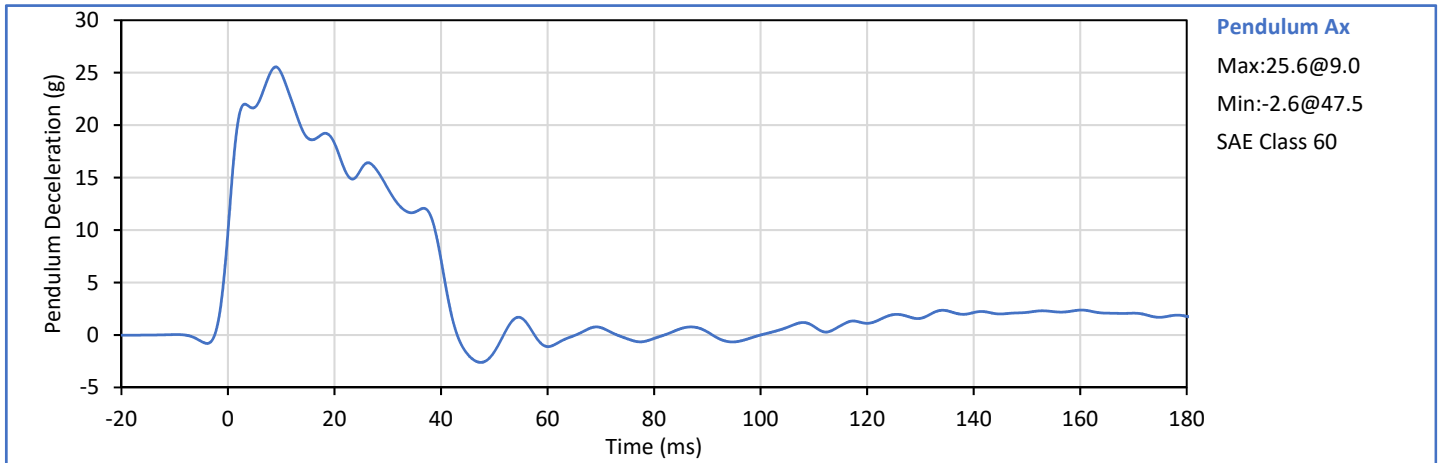
Tested Parameter	Units	Spec. Low	Spec. High	Result	Pass/Fail
Laboratory Temperature	°C	20.6	22.2	20.9	Pass
Laboratory Humidity	%	10	70	23	Pass
Pendulum Velocity	m/s	6.89	7.13	6.99	Pass
Pendulum Deceleration at 10 ms	g	22.5	27.5	25.0	Pass
Pendulum Deceleration at 20 ms	g	17.6	22.6	18.3	Pass
Pendulum Deceleration at 30 ms	g	12.5	18.5	14.0	Pass
Peak Pendulum Decel. after 30 ms	g	0.0	29.0	14.0	Pass
Deceleration Decay to Cross 5 g	ms	34.0	42.0	40.8	Pass
"D" Plane Rotation peak	deg	64.0	78.0	73.4	Pass
	ms	57.0	64.0	60.5	Pass
"D" Plane Rotation Decay To Zero	ms	113.0	128.0	120.8	Pass
Moment About Occipital Condyle	Nm	88.1	108.5	98.2	Pass
	ms	47.0	58.0	54.0	Pass
Moment Decay, Peak to Zero	ms	97.0	107.0	97.1	Pass
Overall Test Results					Pass

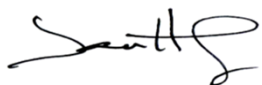

Technician: 
J. Hernandez

Approved By: 
P. Puzzuto

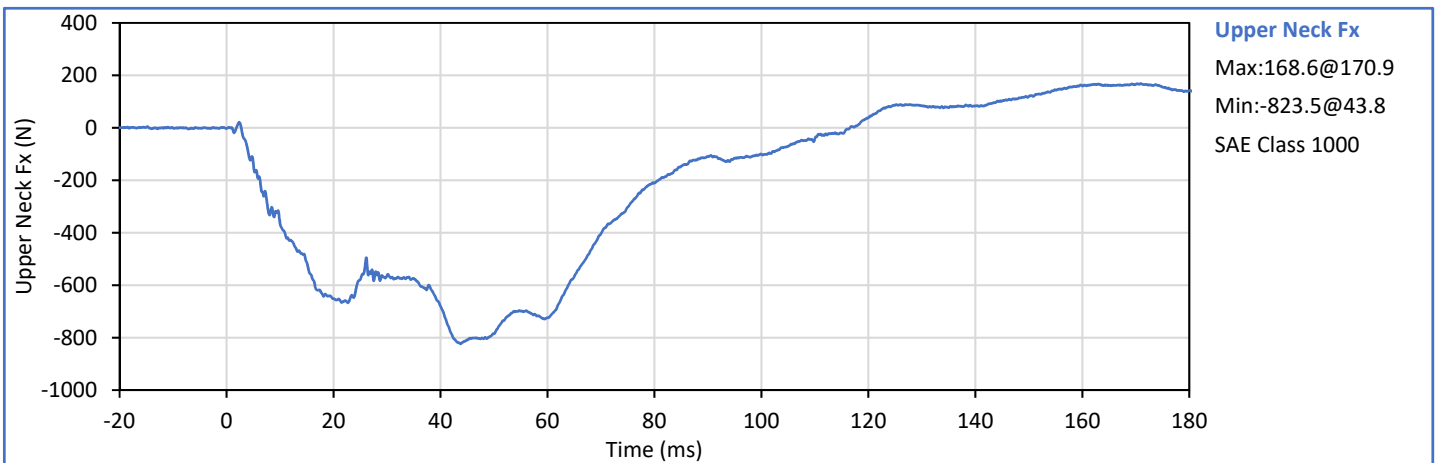
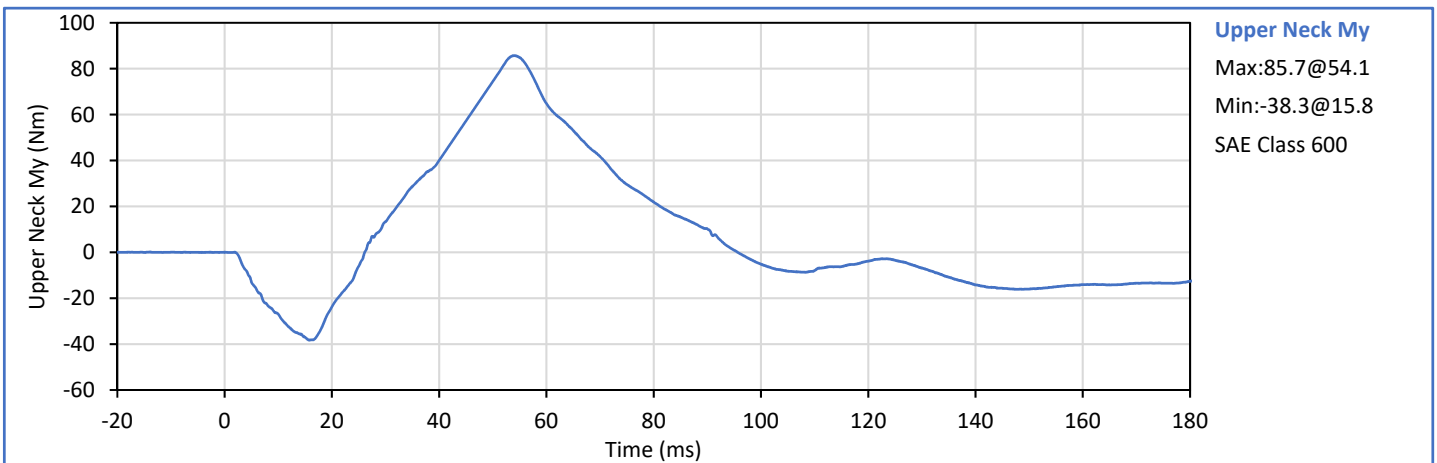
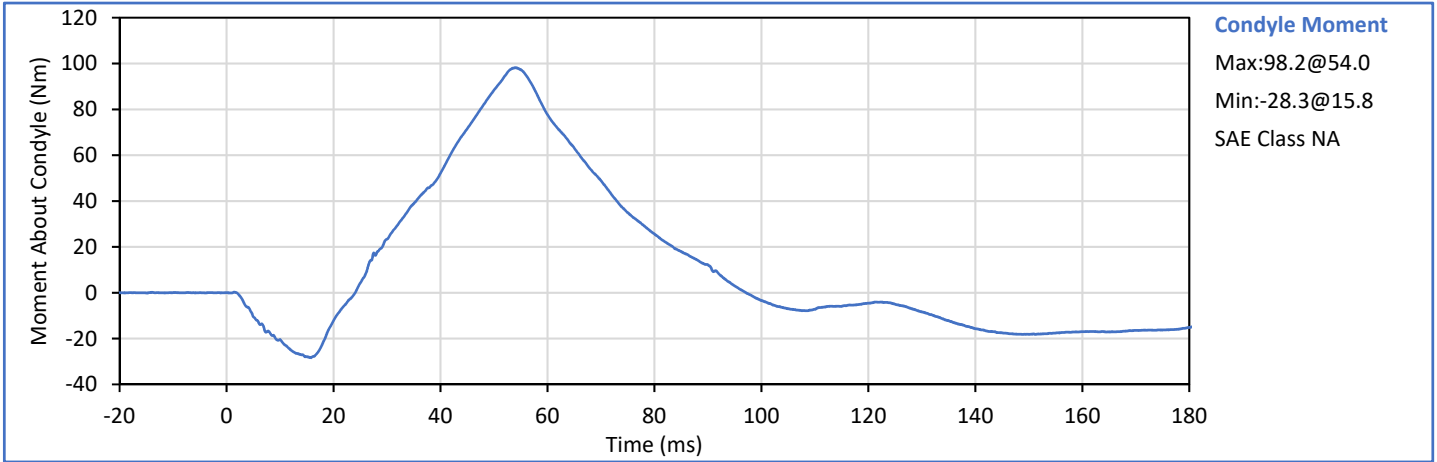

Tested Parameter	Units	Spec. Low	Spec. High	Result	Pass/Fail
Laboratory Temperature	°C	20.6	22.2	21.4	Pass
Laboratory Humidity	%	10	70	22	Pass
Pendulum Velocity	m/s	5.94	6.19	5.99	Pass
Pendulum Deceleration at 10 ms	g	17.2	21.2	20.2	Pass
Pendulum Deceleration at 20 ms	g	14.0	19.0	17.2	Pass
Pendulum Deceleration at 30 ms	g	11.0	16.0	13.8	Pass
Peak Pendulum Decel. after 30 ms	g	0.0	22.0	13.8	Pass
Deceleration Decay to Cross 5 g	ms	38.0	46.0	40.8	Pass
"D" Plane Rotation peak	deg	81.0	106.0	99.0	Pass
	ms	72.0	82.0	76.9	Pass
"D" Plane Rotation Decay To Zero	ms	147.0	174.0	157.4	Pass
Moment About Occipital Condyle	Nm	-79.9	-52.9	-70.8	Pass
	ms	65.0	79.0	70.7	Pass
Moment Decay, Peak to Zero	ms	120.0	148.0	138.8	Pass
Overall Test Results					Pass

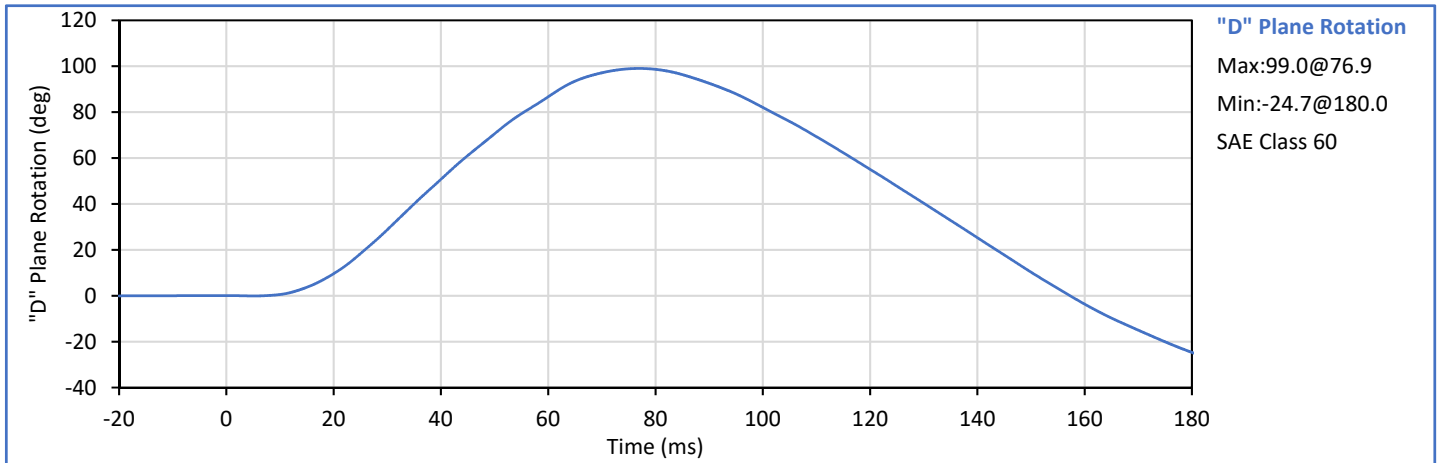
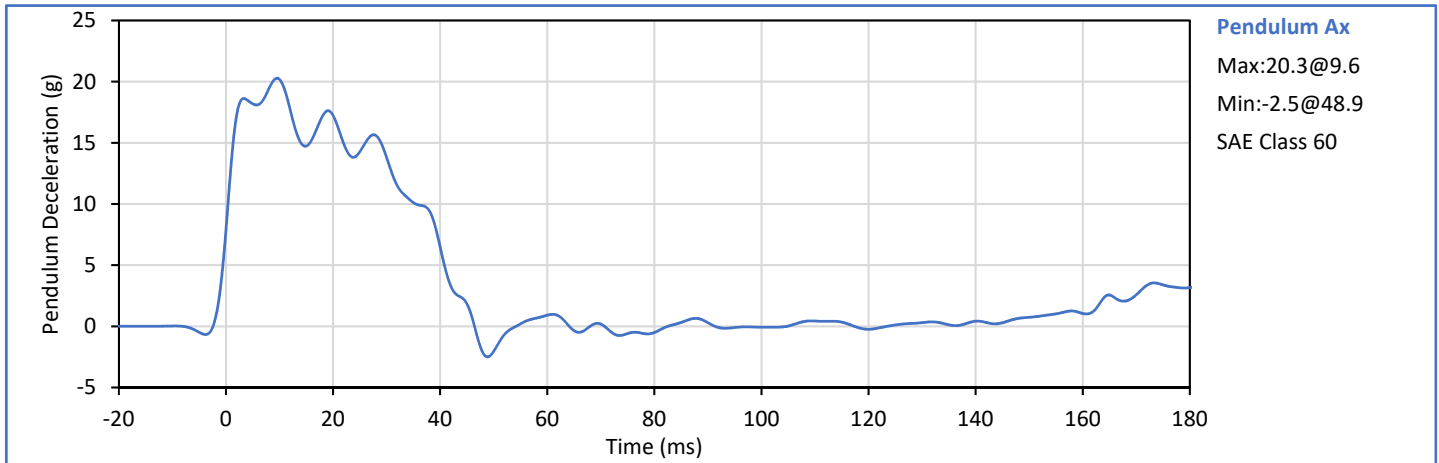

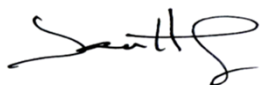
Technician: 
J. Hernandez

Approved By: 
P. Puzzuto

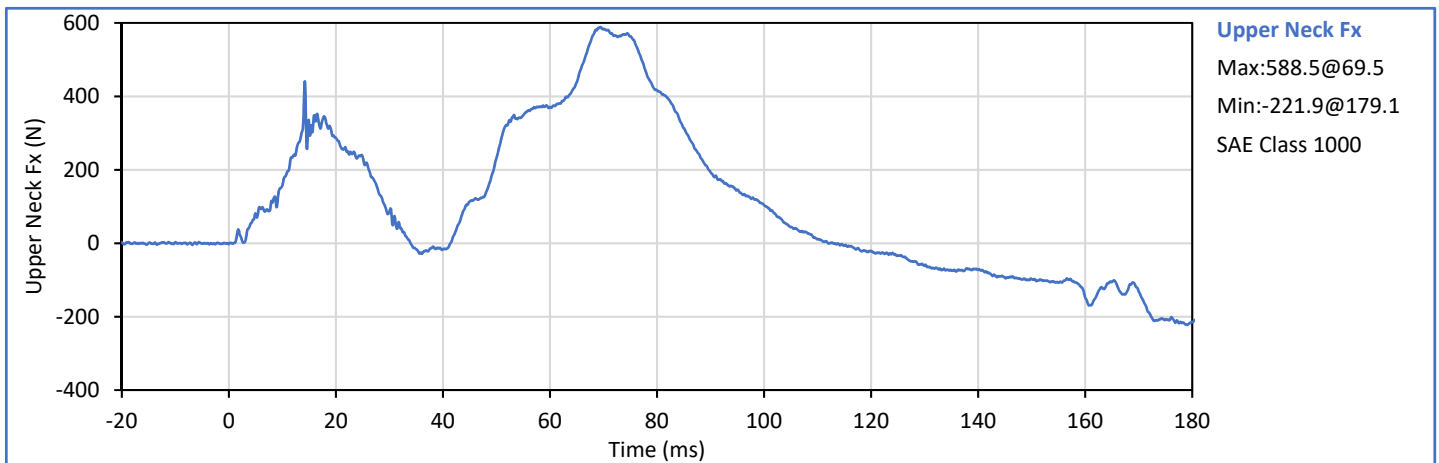
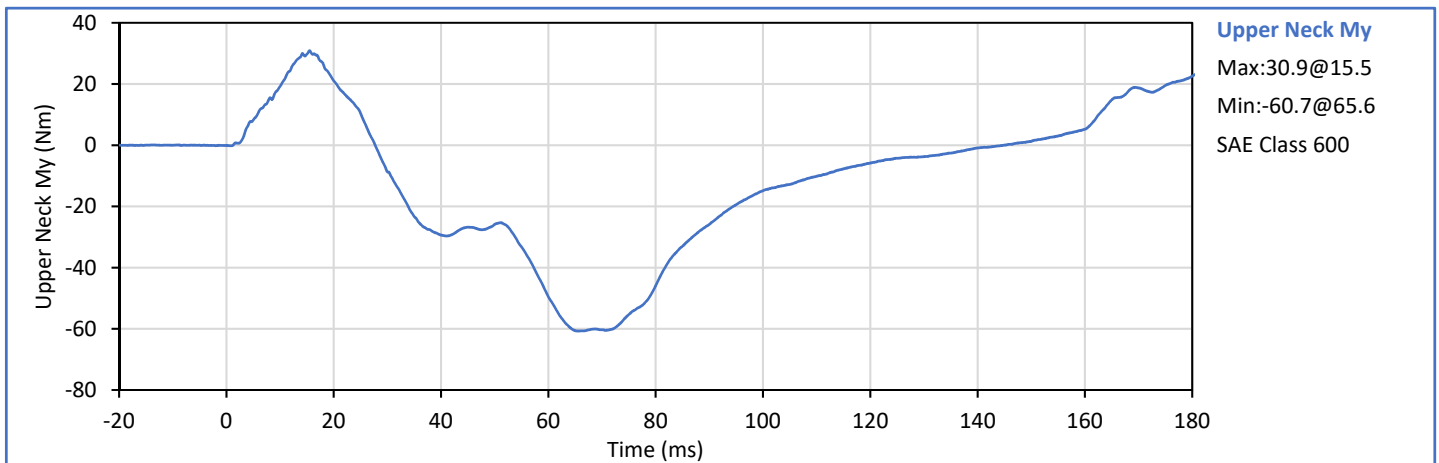
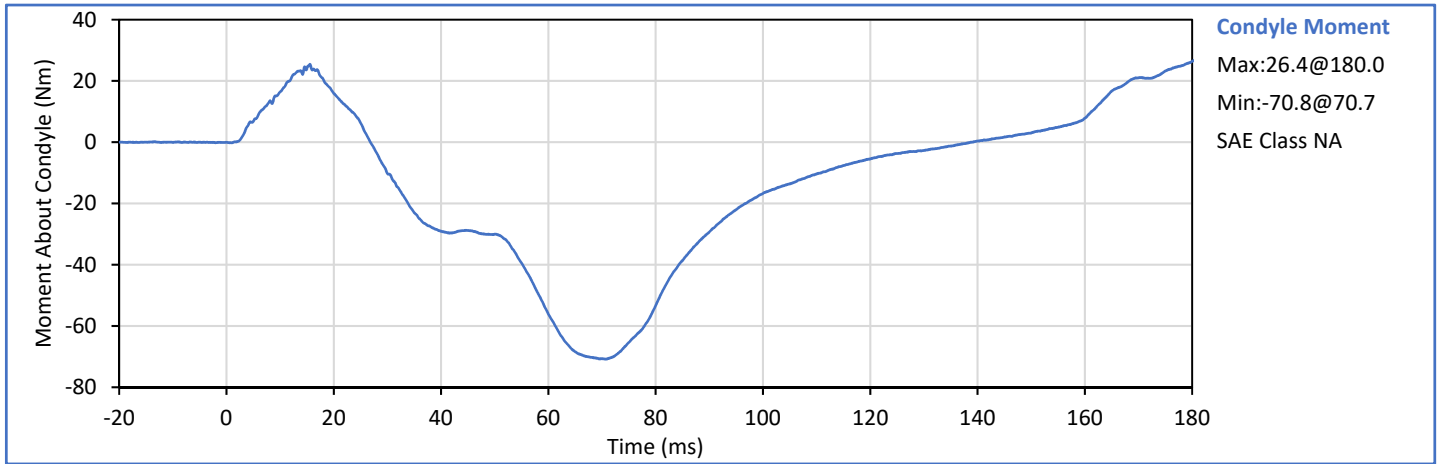

Tested Parameter	Units	Spec. Low	Spec. High	Result	Pass/Fail
Laboratory Temperature	°C	20.6	22.2	21.9	Pass
Laboratory Humidity	%	10	70	24	Pass
Probe Velocity	m/s	6.58	6.82	6.63	Pass
Peak Chest Deflection	cm	6.35	7.26	7.05	Pass
Peak Probe Force	kN	5.159	5.893	5.708	Pass
Internal Hysteresis	%	69.0	85.0	70.2	Pass
Overall Test Results					Pass

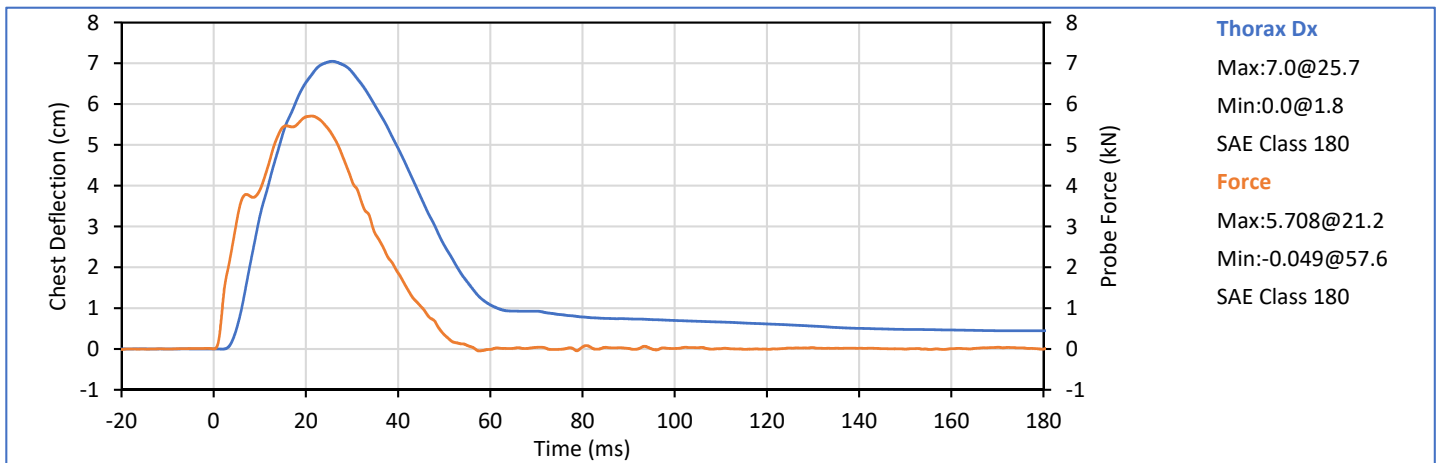
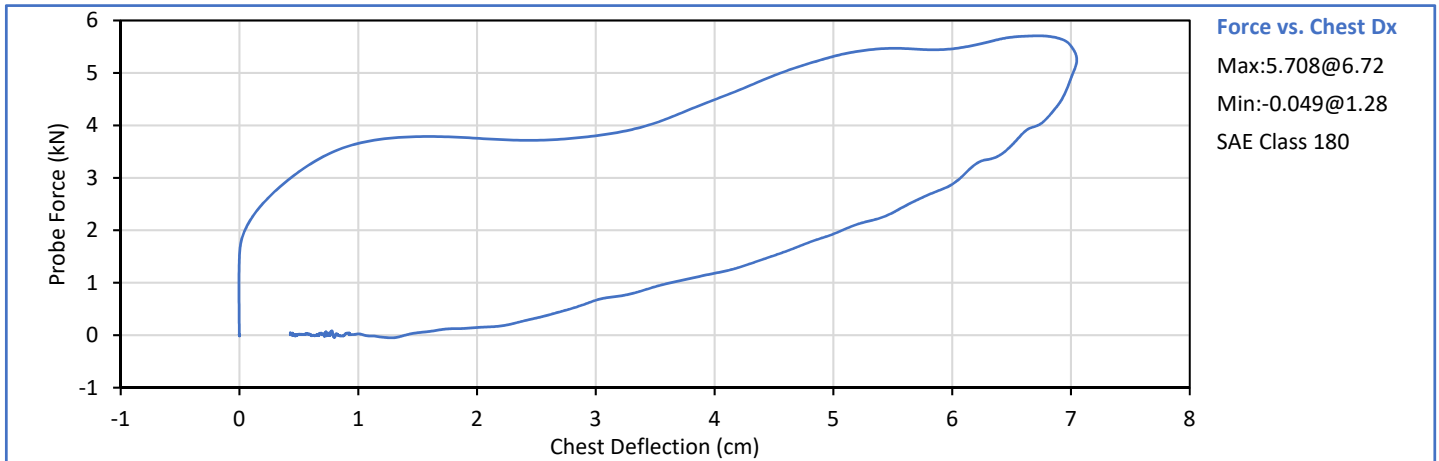

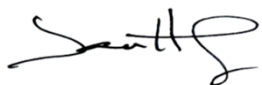

Technician: 
 J. Hernandez

Approved By: 
 P. Puzzuto

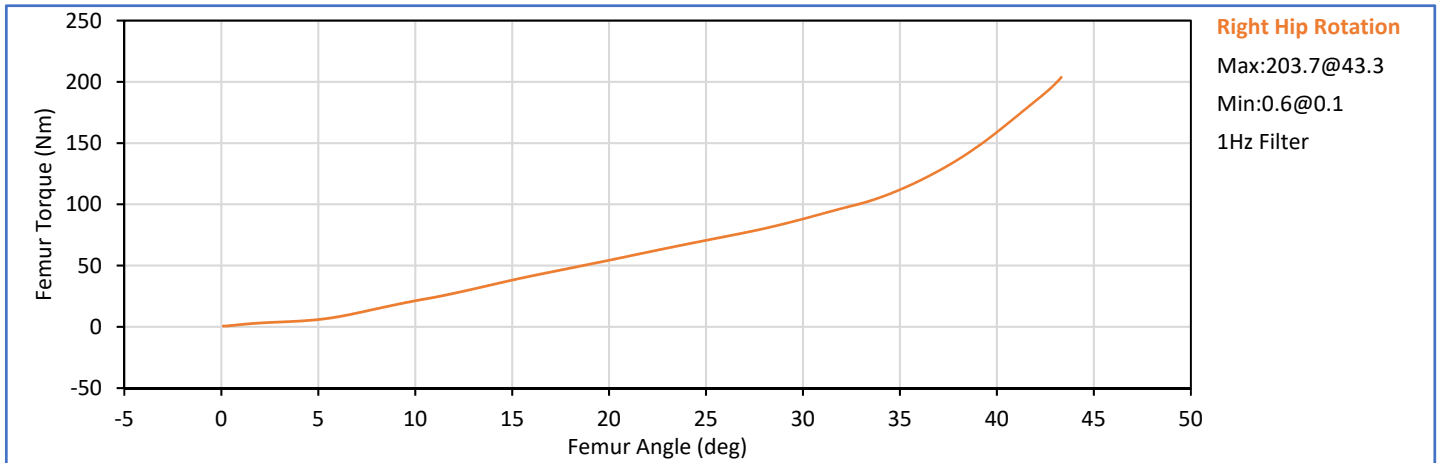
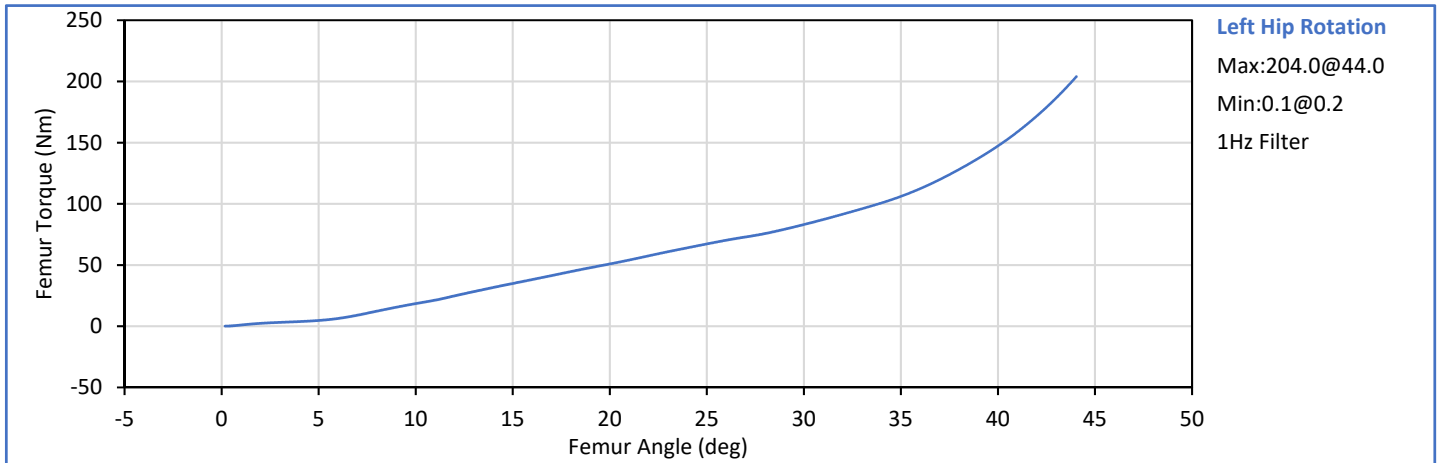
	Tested Parameter	Units	Spec. Low	Spec. High	Result	Pass/Fail
	Laboratory Temperature	°C	18.9	25.6	21.6	Pass
	Laboratory Humidity	%	10	70	24	Pass
Left Hip	Left Hip Rotation Rate	deg/s	5.0	10.0	5.8	Pass
	Left Femur Torque at 30°	Nm	0.0	95.0	83.1	Pass
	Left Hip Rotation at 203 Nm	deg	40.0	50.0	44.0	Pass
Right Hip	Right Hip Rotation Rate	deg/s	5.0	10.0	5.8	Pass
	Right Femur Torque at 30°	Nm	0.0	95.0	88.2	Pass
	Right Hip Rotation at 203 Nm	deg	40.0	50.0	43.3	Pass
Overall Test Results						Pass

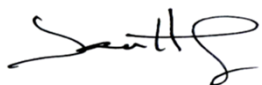

Technician: 
J. Hernandez

Approved By: 
P. Puzzuto

	Tested Parameter	Units	Spec. Low	Spec. High	Result	Pass/Fail
	Laboratory Temperature	°C	18.9	25.6	21.2	Pass
	Laboratory Humidity	%	10	70	21	Pass
Left	Probe Velocity	m/s	2.070	2.130	2.093	Pass
Knee	Peak Resistive Force	N	4715	5782	5197	Pass
Right	Probe Velocity	m/s	2.070	2.130	2.095	Pass
Knee	Peak Resistive Force	N	4715	5782	5309	Pass
					Overall Test Results	Pass

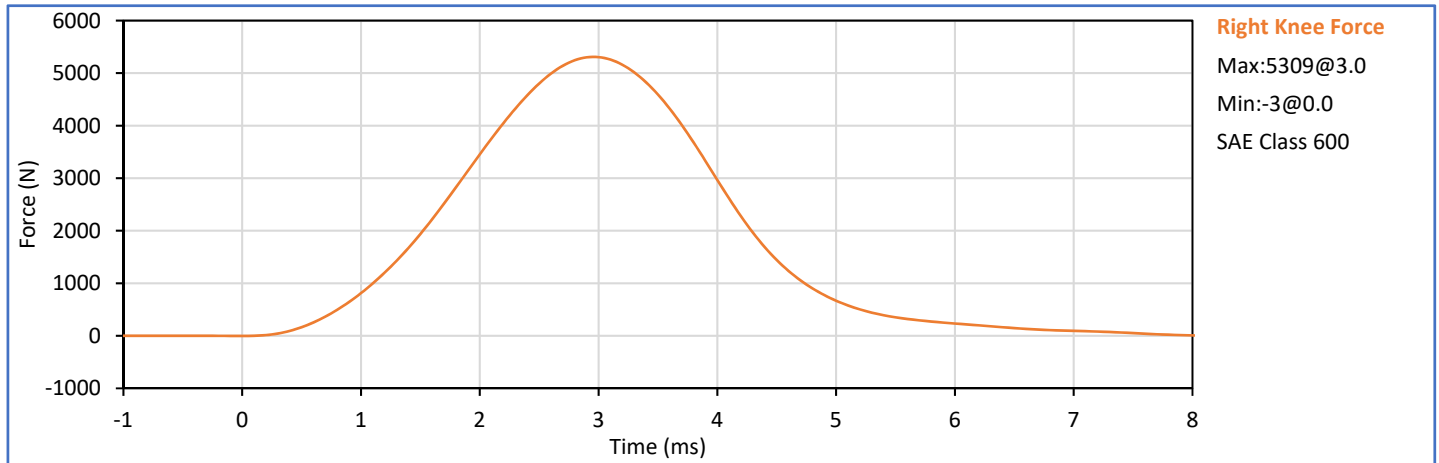
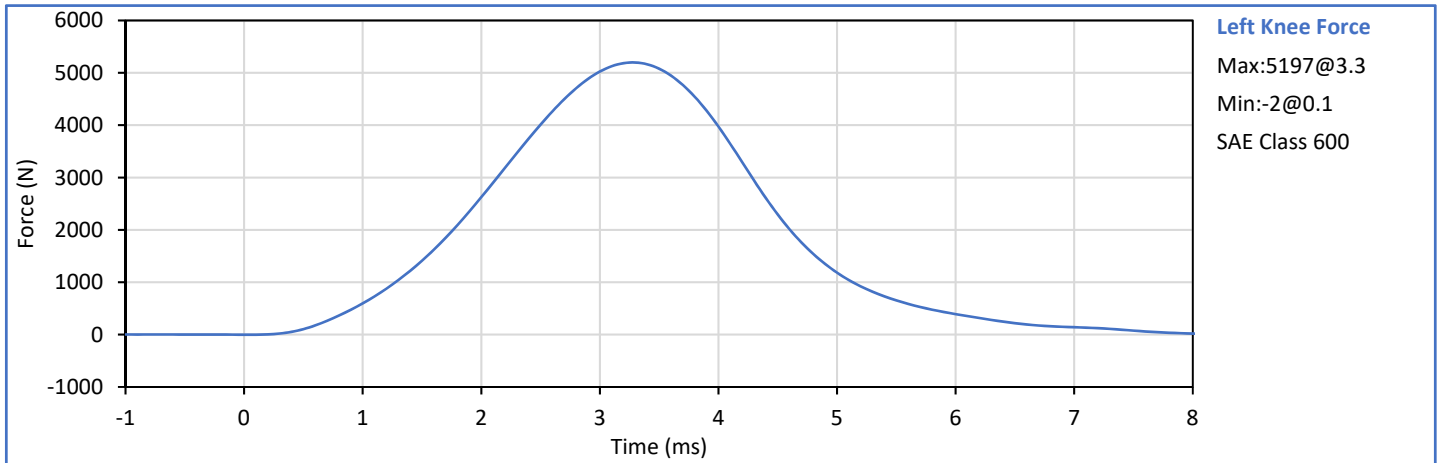

Technician: J. Hernandez

Approved By: P. Puzzuto

APPENDIX C
Post-Test ATD Configuration And Performance Verification Data
Hybrid III 5th Percentile Female ATD
S/N: 141

Dummy Item	Inspect for	Comments	Damage	Okay
Entire ATD	Perform general cleaning			✓
Outer Skin	Gashes, rips, cracks			✓
Head	Ballast secure			✓
	General appearance			✓
Neck bracket	Upper neck firmly attached to lower bracket			✓
Neck	Broken or cracked rubber			✓
	Looseness at the condyle joint			✓
Nodding block	Cracked or out of position			✓
Lumbar Spine	Broken or cracked rubber			✓
Ribs	Broken or bent ribs			✓
	Broken or bent rib supports			✓
	Damping material separated or cracked			✓
	Rubber bumpers in place			✓
Chest Displ. Assembly	Bent shaft			✓
	Slider arm riding in track			✓
Sensors	Check cables for cuts, tears			✓
	Check for damaged insulation			✓
Accelerometer Mounting	Head mounting secure			✓
	Chest mounting secure			✓
Knees	Skin condition			✓
	Insert (do not remove)			✓
	Casting			✓
Limbs	Normal movement and adjustment			✓
Knee Sliders	Wires intact			✓
	Rubber returned to "resting" position			✓
Pelvis	Broken			✓
Other	Describe below as needed			✓

Describe any repairs or replacement of parts or other findings:

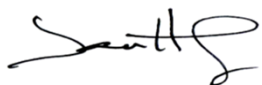
Technician: 
J. Hernandez

Approved By: 
P. Puzzuto

Tested Parameter	Units	Spec. Low	Spec. High	Result	Pass/Fail
Laboratory Temperature	°C	20.6	22.2	21.1	Pass
Laboratory Relative Humidity	%	10	70	22	Pass
A - Total sitting height	mm	775	800	796	Pass
B - Shoulder pivot height	mm	432	457	441	Pass
C - 'H' point height	mm	81	86	84	Pass
D - 'H' point location from backline	mm	145	150	147	Pass
E - Shoulder pivot from backline	mm	69	84	73	Pass
F - Thigh clearance	mm	119	135	126	Pass
G - Back of elbow to wrist pivot	mm	244	259	249	Pass
H - Head back to backline	mm	41	46	43	Pass
I - Shoulder to elbow length	mm	277	297	289	Pass
J - Elbow rest height	mm	183	203	194	Pass
K - Buttock to knee length	mm	521	546	531	Pass
L - Popliteal length	mm	356	376	365	Pass
M - Knee pivot height	mm	394	419	407	Pass
N - Buttock popliteal length	mm	414	439	428	Pass
O - Chest depth without jacket	mm	175	191	185	Pass
P - Foot length	mm	219	234	226	Pass
R - Buttock to Knee Pivot Length	mm	457	483	475	Pass
S - Head Breadth	mm	137	147	144	Pass
T - Head Depth	mm	178	188	187	Pass
U - Hip Breadth	mm	300	315	303	Pass
V - Shoulder breadth	mm	351	366	361	Pass
W - Foot breadth	mm	79	94	82	Pass
X - Head circum.	mm	528	549	537	Pass
Y - Chest circum. (w/chest jacket)	mm	851	881	875	Pass
Z - Waist circum.	mm	760	790	772	Pass
AA - Location for chest circum.	mm	333	358	338	Pass
BB - Location for waist circum.	mm	160	170	164	Pass
Overall Test Results					Pass

Technician:



J. Hernandez

Approved By:



P. Puzzuto

Tested Parameter	Units	Spec. Low	Spec. High	Result	Pass/Fail
Laboratory Temperature	°C	18.9	25.6	21.9	Pass
Laboratory Humidity	%	10	70	25	Pass
Peak Resultant Acceleration	g	250.0	300.0	273.9	Pass
Peak Lateral Acceleration	g	-15.0	15.0	5.6	Pass
Oscillations After Main Pulse	%	0.0	10.0	1.0	Pass
Is Acceleration Unimodal?	Yes/No	Yes		Yes	Pass
Overall Test Results					Pass

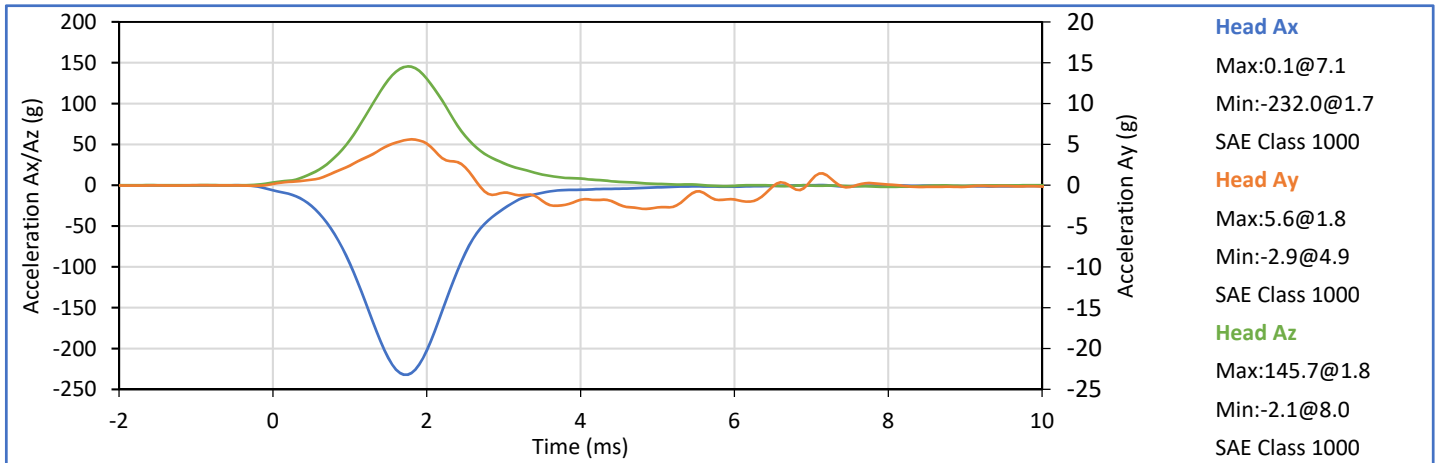
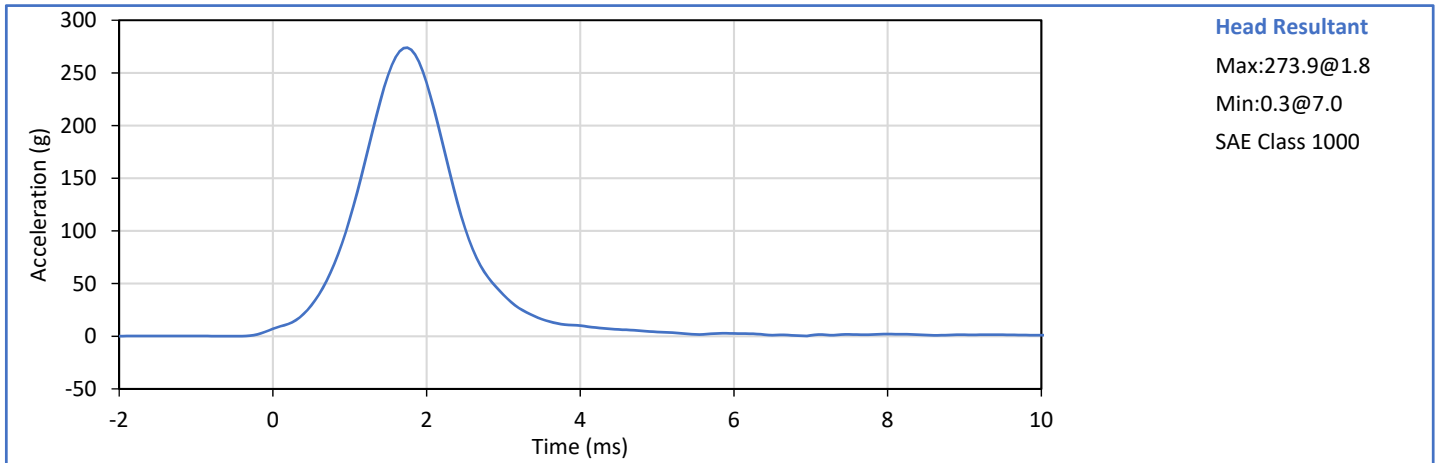



Technician: 
J. Hernandez

Approved By: 
P. Puzzuto

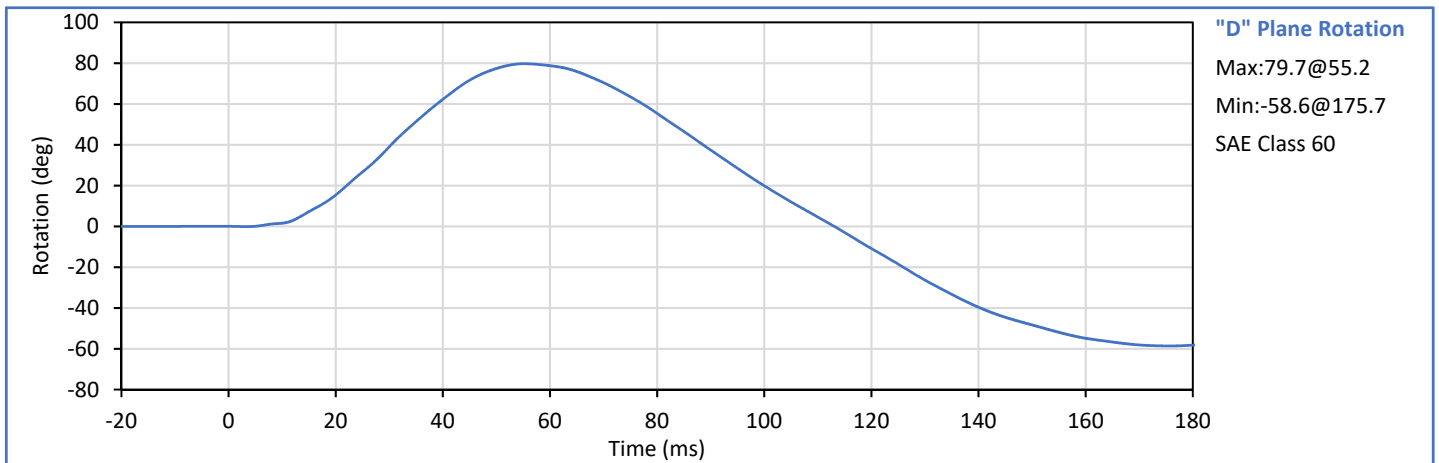
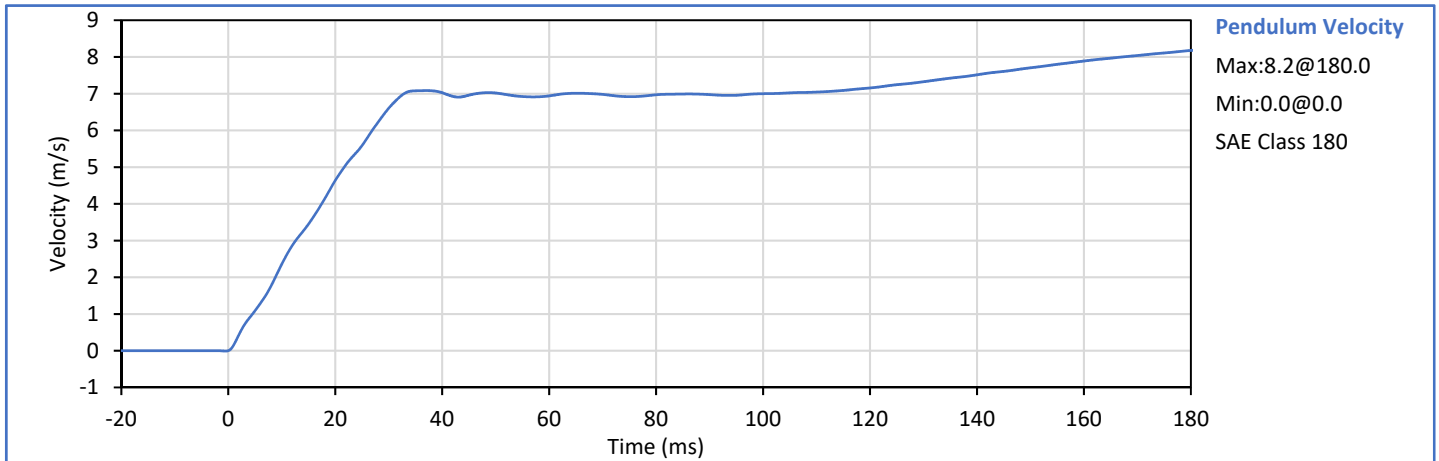
Tested Parameter	Units	Spec. Low	Spec. High	Result	Pass/Fail
Laboratory Temperature	°C	20.6	22.2	21.4	Pass
Laboratory Humidity	%	10	70	22	Pass
Pendulum Velocity	m/s	6.89	7.13	6.91	Pass
Pendulum Velocity at 10 ms	m/s	2.10	2.50	2.36	Pass
Pendulum Velocity at 20 ms	m/s	4.00	5.00	4.64	Pass
Pendulum Velocity at 30 ms	m/s	5.80	7.00	6.60	Pass
Peak "D" Plane Rotation	deg	77.0	91.0	79.7	Pass
Peak Moment in Rotation	Nm	69.0	83.0	81.4	Pass
Positive Moment Decay to 10 Nm	ms	80.0	100.0	82.6	Pass
Overall Test Results					Pass

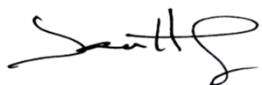

Technician: 
J. Hernandez

Approved By: 
P. Puzzuto

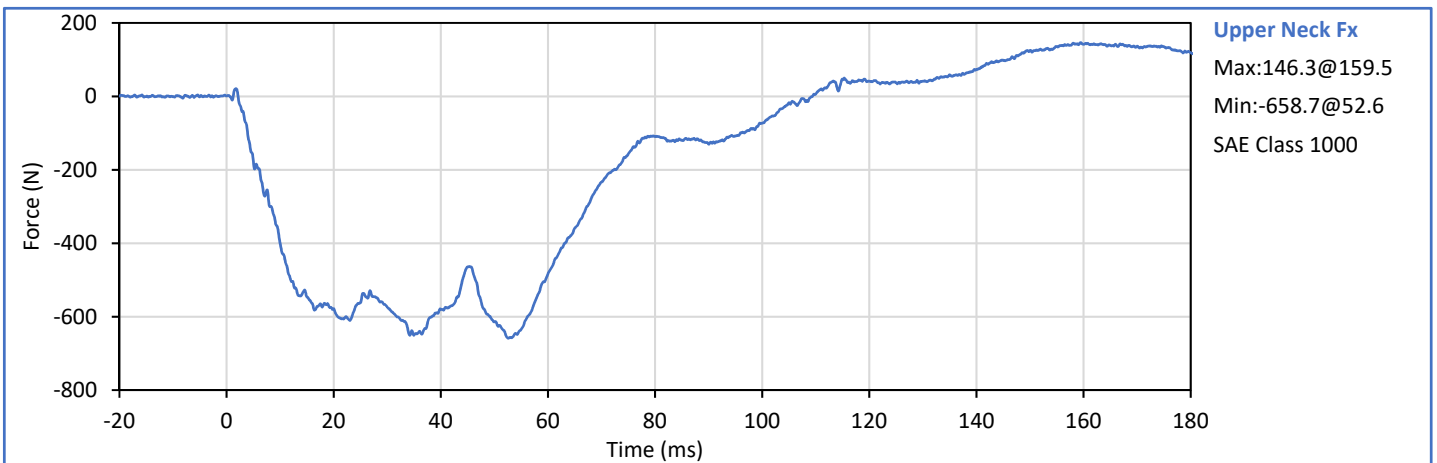
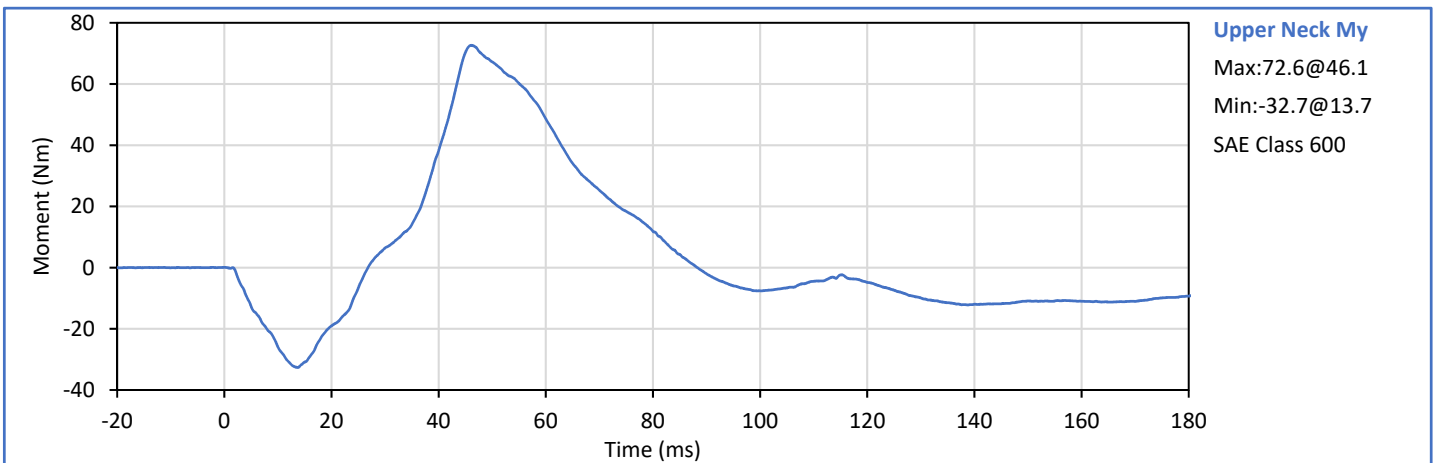
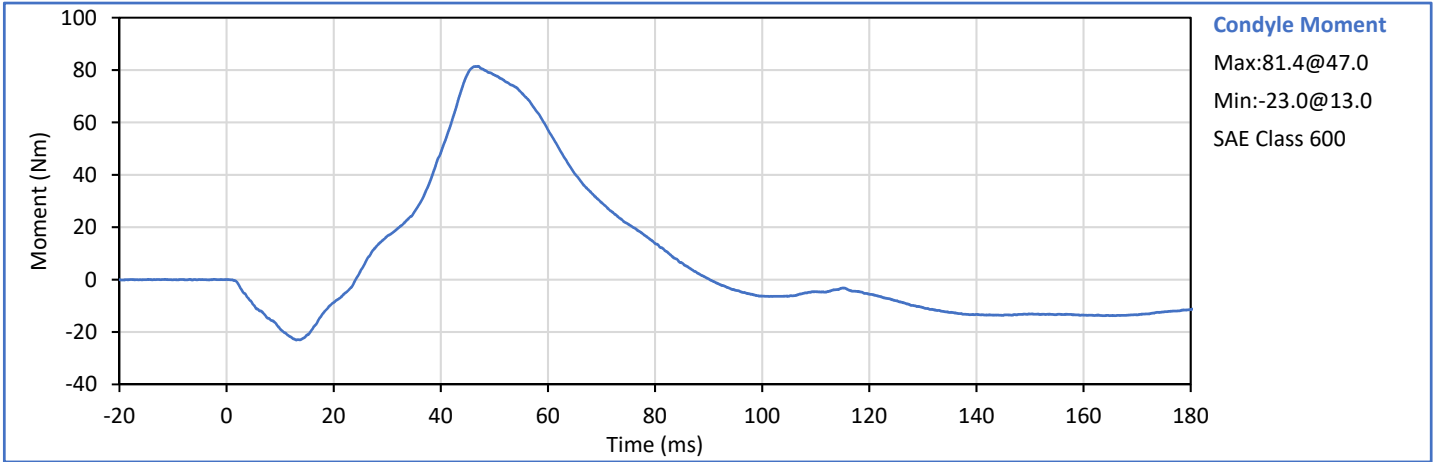

Tested Parameter	Units	Spec. Low	Spec. High	Result	Pass/Fail
Laboratory Temperature	°C	20.6	22.2	21.9	Pass
Laboratory Humidity	%	10	70	25	Pass
Pendulum Velocity	m/s	5.95	6.19	6.08	Pass
Pendulum Velocity at 10 ms	m/s	1.50	1.90	1.77	Pass
Pendulum Velocity at 20 ms	m/s	3.10	3.90	3.50	Pass
Pendulum Velocity at 30 ms	m/s	4.60	5.60	5.07	Pass
Peak "D" Plane Rotation	deg	99.0	114.0	106.8	Pass
Peak Moment in Rotation	Nm	-65.0	-53.0	-59.4	Pass
Negative Moment Decay to -10 Nm	ms	94.0	114.0	101.7	Pass
Overall Test Results					Pass

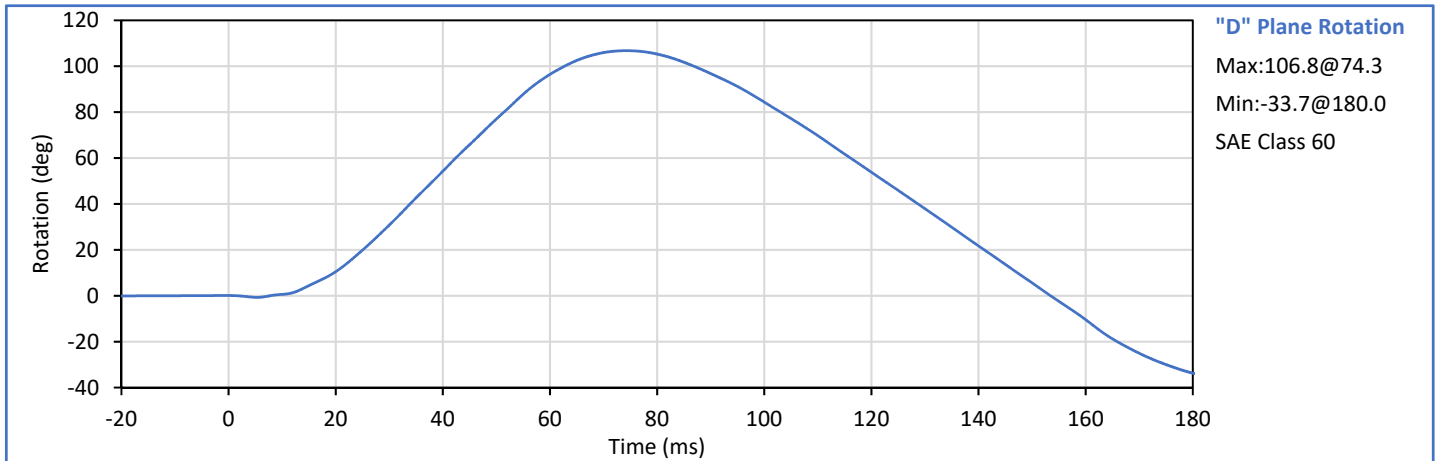
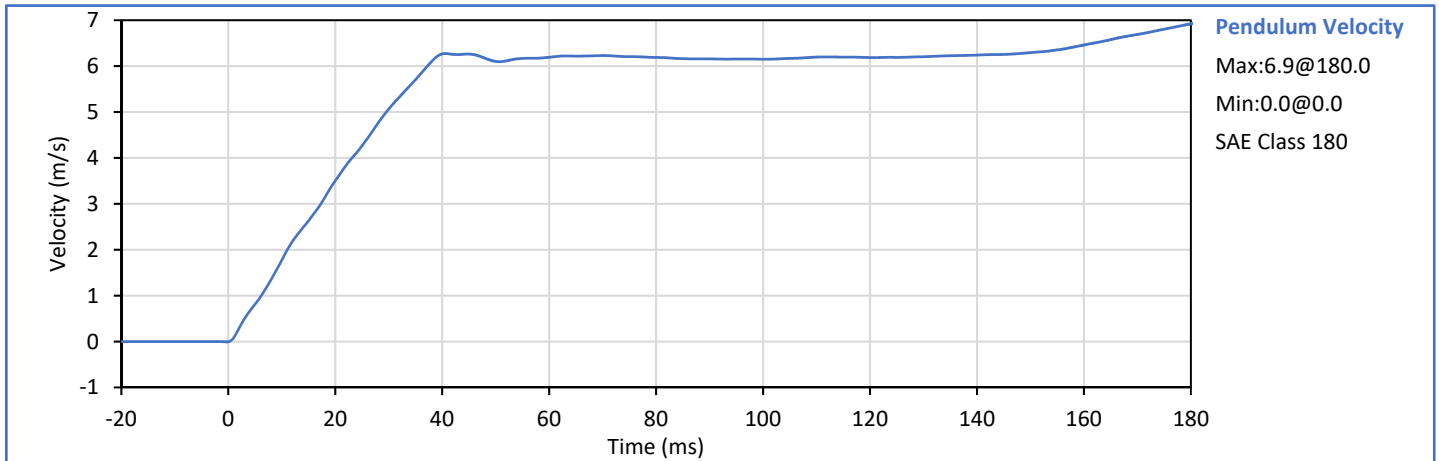

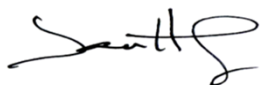
Technician: 
J. Hernandez

Approved By: 
P. Puzzuto

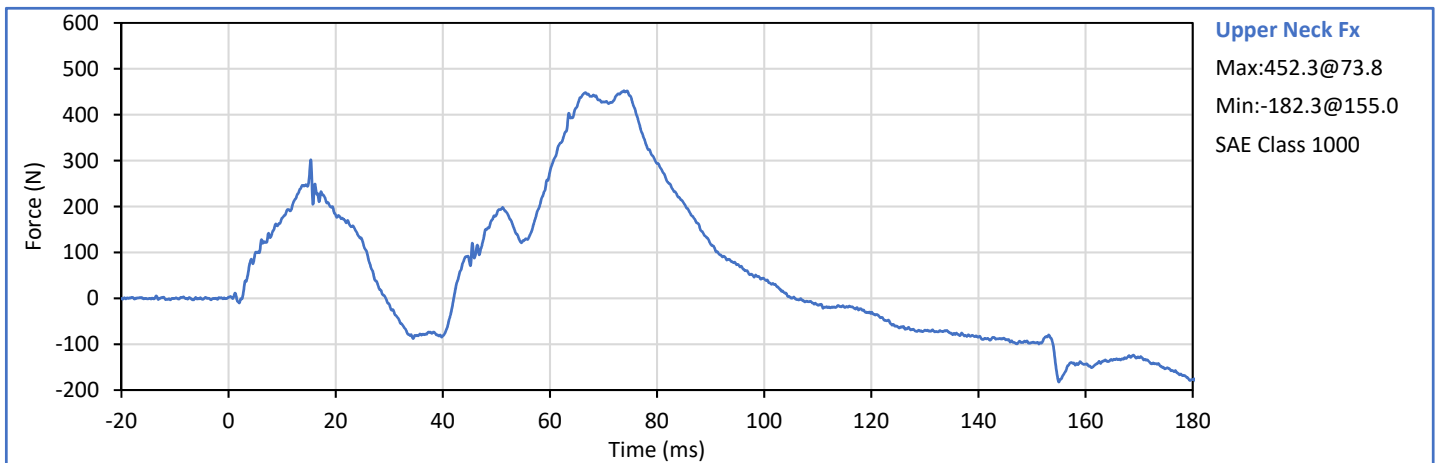
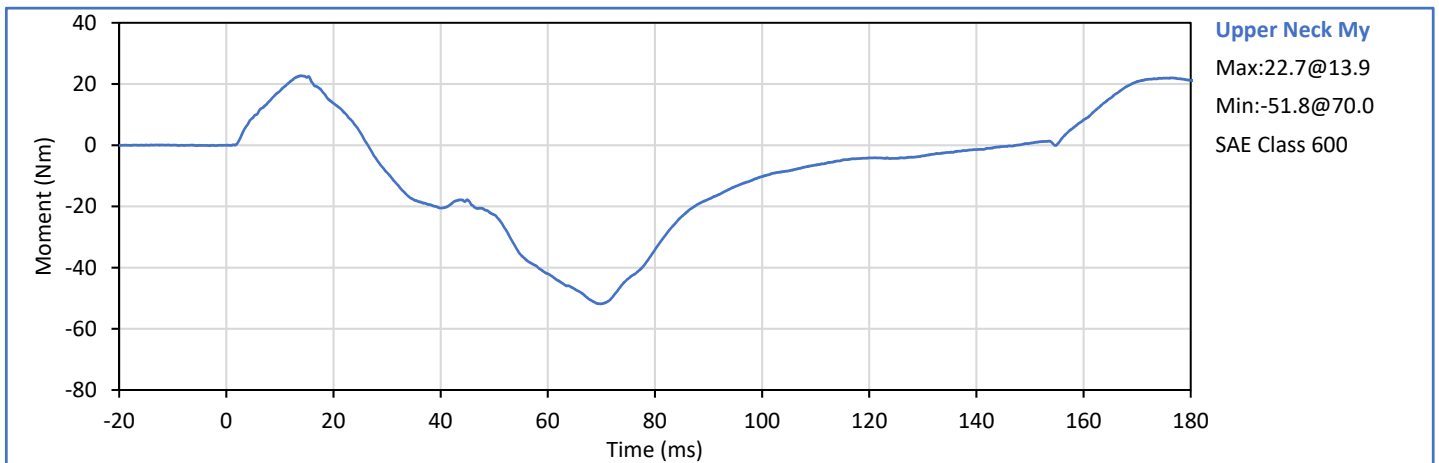
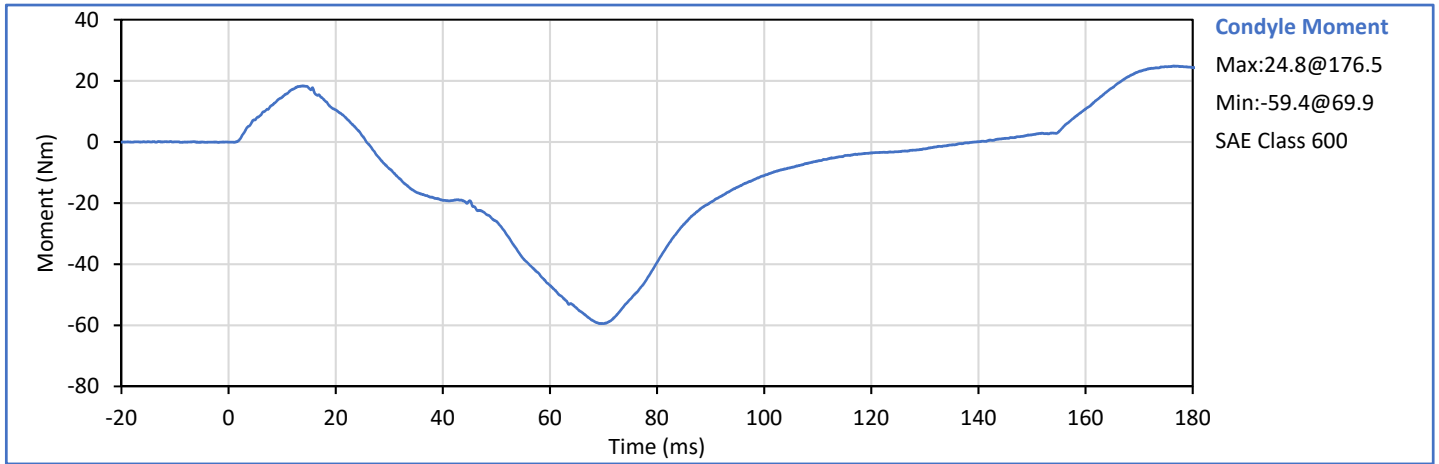

Tested Parameter	Units	Spec. Low	Spec. High	Result	Pass/Fail
Laboratory Temperature	°C	20.6	22.2	21.2	Pass
Laboratory Humidity	%	10	70	23	Pass
Probe Velocity	m/s	6.59	6.83	6.66	Pass
Peak Chest Deflection	mm	50.0	58.0	53.4	Pass
Peak Probe Force, 50 and 58 mm	kN	3.900	4.400	4.261	Pass
Peak Probe Force, 18 and 50 mm	kN	0.000	4.600	4.251	Pass
Internal Hysterisis	%	69.0	85.0	73.6	Pass
Overall Test Results					Pass

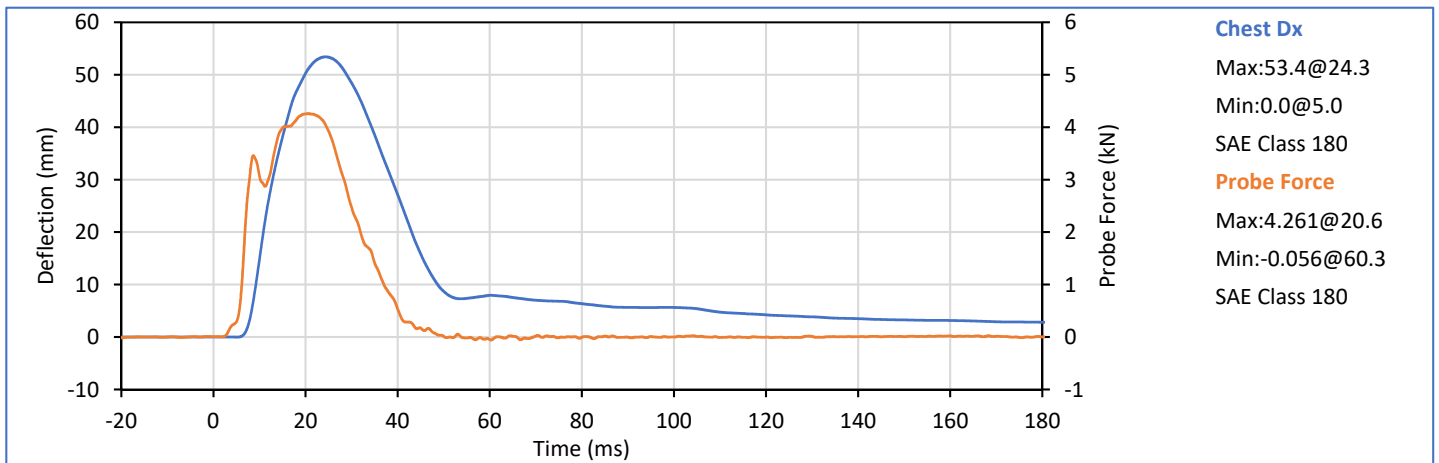
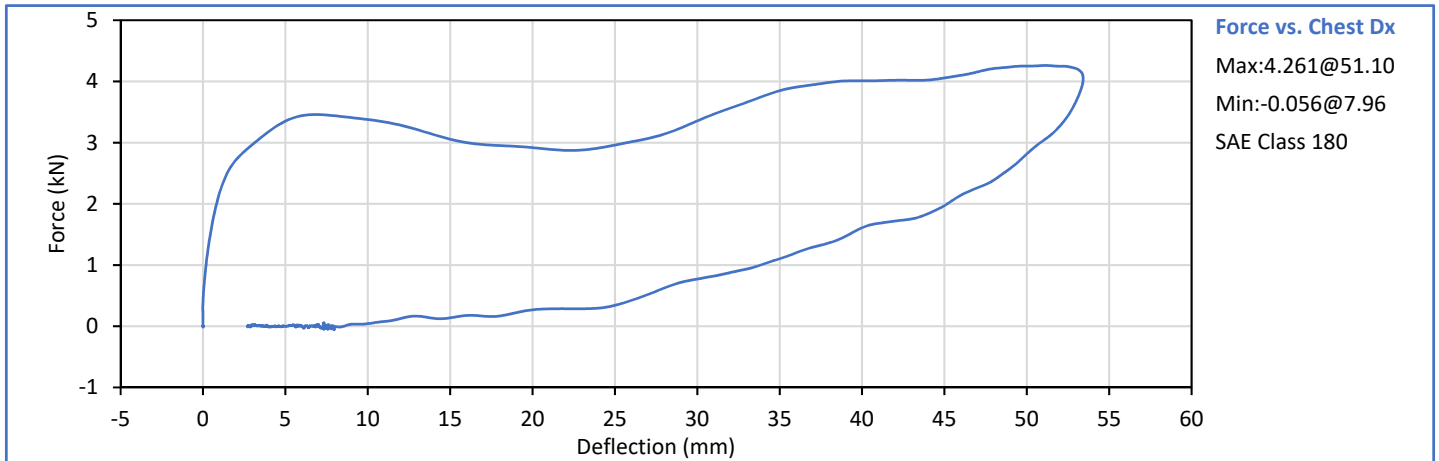

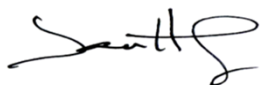
Technician: 
 J. Hernandez

Approved By: 
 P. Puzzuto

ATD Serial No.: 141

Test Date: 2019-03-12

Tested Parameter	Units	Spec. Low	Spec. High	Result	Pass/Fail
Laboratory Temperature	°C	18.9	25.6	21.6	Pass
Laboratory Humidity	%	10	70	23	Pass
Orientation Angle	deg	0.0	20.0	14.5	Pass
Test Initial Angle	deg	11.0	19.0	15.3	Pass
Peak Force at 45° (+/-0.5°)	N	320.0	390.0	341.1	Pass
Torso Flexion Rate	deg/s	0.50	1.50	1.00	Pass
Final Reference Plane Angle	deg	-8.0	8.0	4.6	Pass
Overall Test Results					Pass

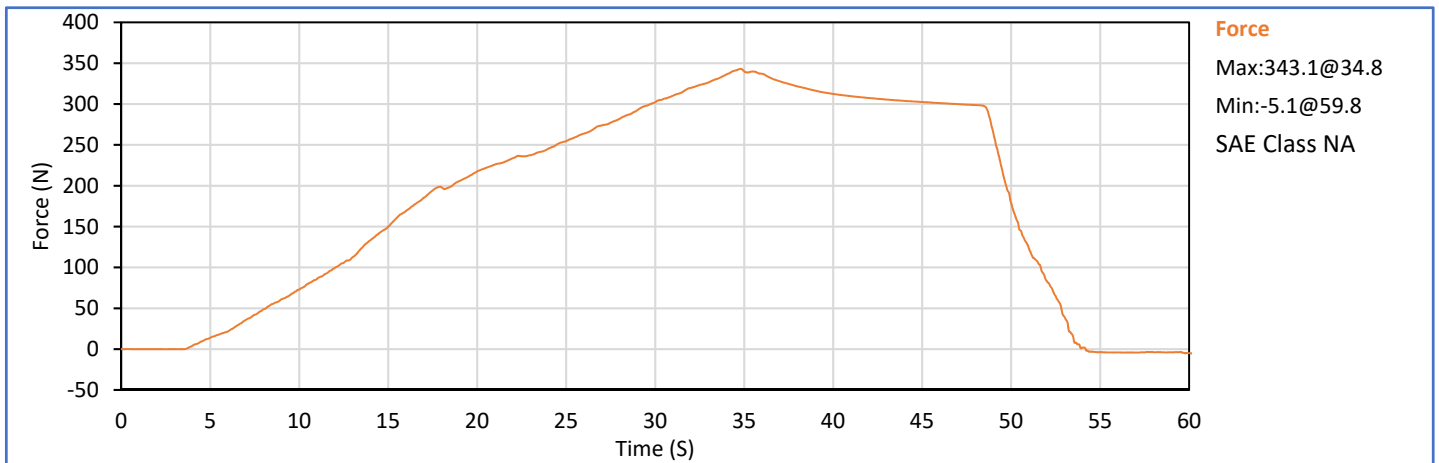
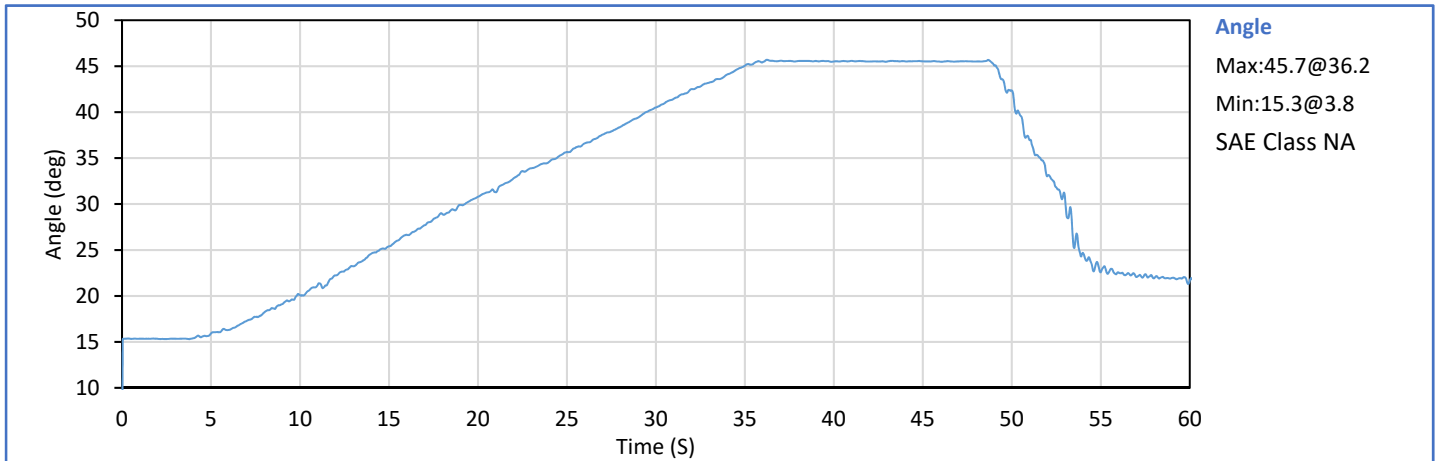

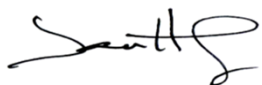
Technician: 
J. Hernandez

Approved By: 
P. Puzzuto

	Tested Parameter	Units	Spec. Low	Spec. High	Result	Pass/Fail
	Laboratory Temperature	°C	18.9	25.6	21.6	Pass
	Laboratory Humidity	%	10	70	34	Pass
Left	Probe Velocity	m/s	2.070	2.130	2.085	Pass
Knee	Peak Resistive Force	N	3450	4060	3875	Pass
Right	Probe Velocity	m/s	2.070	2.130	2.079	Pass
Knee	Peak Resistive Force	N	3450	4060	4051	Pass
Overall Test Results						Pass

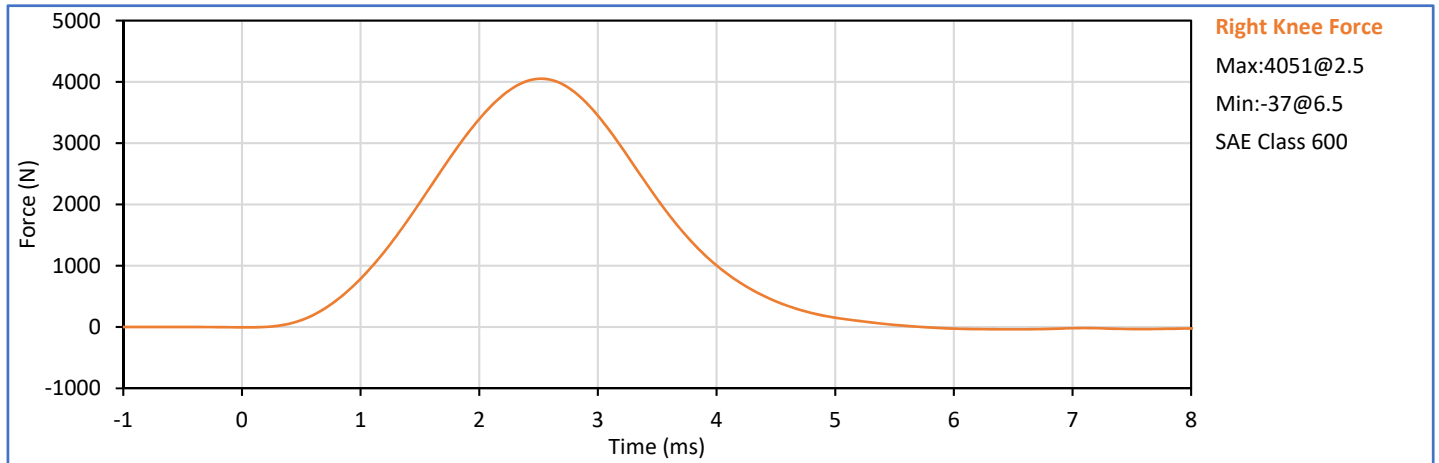
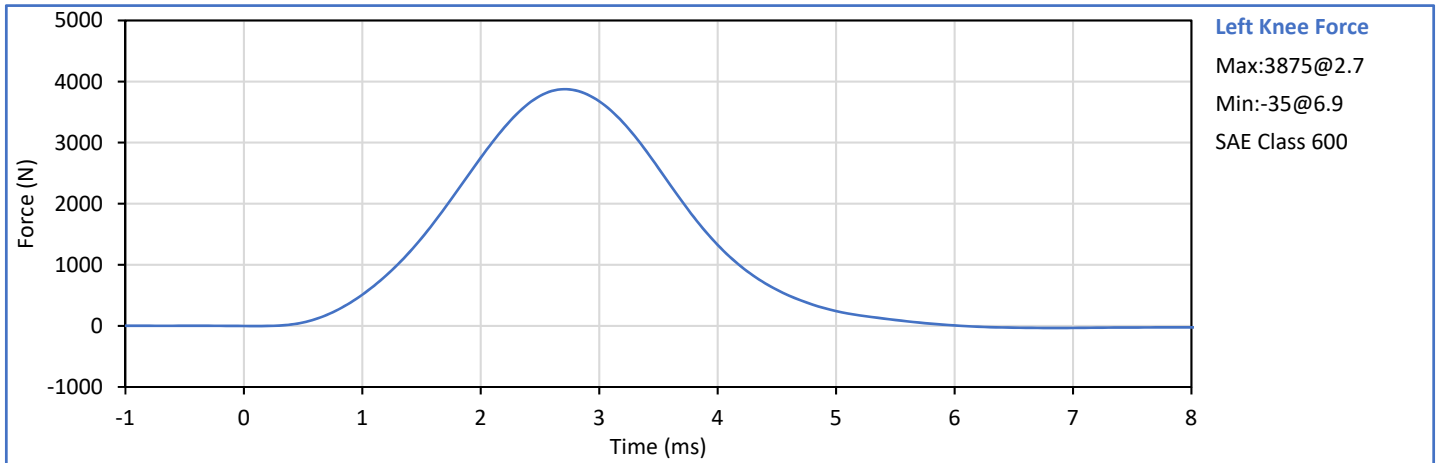

Technician: *J. Hernandez*
J. Hernandez

Approved By: *P. Puzzuto*
P. Puzzuto