

**NEW CAR ASSESSMENT PROGRAM (NCAP)
DYNAMIC ROLLOVER RESISTANCE TEST**

FCA US LLC

2019 Jeep Wrangler Unlimited 4WD

TEST NUMBER: 19-13

Final Report
11 April 2019



Prepared by:

Dynamic Research, Inc
355 Van Ness Ave. #200
Torrance, CA 90501

Prepared for:

National Highway Traffic Safety Administration
Office of Crash Avoidance Standards
1200 New Jersey Avenue S.E.
Washington, DC 20590

The United States Government assumes no liability for the contents of this report or use thereof. If trade or manufacturers' names or products are mentioned, it is only because they are considered essential to the object of the publication and should not be construed as an endorsement. The United States Government does not endorse products or manufacturers.

Dynamic Research, Inc. does not endorse or certify products of manufacturers. The manufacturer's name appears solely to identify the test article. Dynamic Research, Inc. assumes no liability for the report or use thereof. It is responsible for the facts and the accuracy of the data presented herein. This report does not constitute a standard, specification, or regulation.

Report Prepared by:

John Lenkeit, Program Manager

Date: 11 April 2019

1. Report No. 19-13	2. Government Accession No.	3. Recipient's Catalog No.	
4. Title and Subtitle NCAP Dynamic Rollover Resistance Maneuver (Fishhook) Test of a 2019 Jeep Wrangler Unlimited 4WD MPV		5. Report Date 11 April 2019	6. Performing Organization Code DRI
		8. Performing Organization Report No. DRI- TM-18-81	
7. Author(s) John Lenkeit, Program Manager Peter Broen, Project Engineer		10. Work Unit No. (TRAIS)	
9. Performing Organization Name and Address Dynamic Research, Inc. 355 Van Ness Ave. #200 Torrance, CA 90501		11. Contract or Grant No. DTNH22-14-D-00332	
		13. Type of Report and Period Covered Final Report March to April 2019	
12. Sponsoring Agency Name and Address National Highway Traffic Safety Administration Office of Crash Avoidance Standards 1200 New Jersey Avenue S.E. Washington, DC 20590		14. Sponsoring Agency Code	
		15. Supplemental Notes	
16. Abstract An NCAP Dynamic Rollover Maneuver (Fishhook) Test was conducted on a 2019 Jeep Wrangler Unlimited 4WD at Dynamic Research, Inc. on March 20, 2019. The vehicle did not experience two-wheel lift. The vehicle's steering angle at 0.3 g lateral acceleration at 50 mph was 43.3 degrees.			
17. Key Words NCAP Rollover Resistance Ratings Fishhook Test		18. Distribution Statement Copies of this report are available from: National Highway Traffic Safety Admin. Office of Crash Avoidance Standards 1200 New Jersey Ave., S.E. Washington, DC 20590	
19. Security Classif. (of this report) Unclassified	20. Security Classif. (of this page) Unclassified	21. Number of Pages 54	22. Price

TABLE OF CONTENTS

	Page
I. INTRODUCTION.....	1
II. VEHICLE PREPARATION	2
A. Test Vehicle	2
B. Tires	2
C. Vehicle Loading.....	2
D. Steering Controller	5
E. Real-Time Controller and Data Acquisition	5
F. Equipment Weight.....	6
G. Other Vehicle Preparation	7
III. TEST PROCEDURES.....	10
A. Test Procedure Overview.....	10
B. Test Conditions	11
IV. RESULTS.....	14
APPENDIX A Photographs	A-1
APPENDIX B Test Run Log.....	B-1
APPENDIX C Slowly Increasing Steer Test Worksheet.....	C-1
APPENDIX D Time History Plots	D-1

LIST OF FIGURES

	Page
1. Nominal Position of Video Cameras for Fishhook Tests	8
2. DRI-Minter Vehicle Dynamics Area	12

LIST OF TABLES

	Page
1. Test Vehicle Data	3
2. Tire Information	4
3. Vehicle Loading	4
4. Weight of In-Cab Test equipment.....	6
5. Sensor Specifications	10
6. Handwheel Angles	10
7. Weather Conditions.....	11

Section I INTRODUCTION

Beginning with the 2006 fiscal year, the National Highway Traffic Safety Administration (NHTSA) has engaged Dynamic Research, Inc. (DRI) of Torrance, CA to conduct dynamic rollover testing and gather data from that testing as part of NHTSA's New Car Assessment Program (NCAP).

The purpose of the testing reported herein was to determine if a typical 2019 Jeep Wrangler Unlimited 4WD would experience tip-up, defined as simultaneous two-wheel lift of two inches or more at an entry speed of 50 mph or less in the Fishhook Procedure developed by NHTSA. This procedure may be found at www.regulations.gov, docket item NHTSA-2006-26555-0136.

The testing reported herein was accomplished under contract DTNH22-14-D-00332. The task order is entitled, "New Car Assessment Program (NCAP) Non-Destructive Vehicle Testing and Data Gathering."

Section II VEHICLE PREPARATION

A. TEST VEHICLE

The test vehicle was new or in as-new condition, meaning the vehicle had been driven no more than 500 miles prior to the start of dynamic rollover testing. It was acquired through a commercial rental/leasing company. Details of the test vehicle are given in Table 1.

B. TIRES

All tires used were new, and of the same make, model, size, and DOT specification of those installed on the vehicle when purchased new. Tire inflation pressures were in accordance with the recommendations indicated on each vehicle's identification placard. To further reduce the possibility of tire debanding, the tires were mounted to the rims without the use of tire mounting lubricant. Tire specifications are listed in Table 2.

C. VEHICLE LOADING

The multi-passenger load, described in the Fishhook Procedure, was used for all tests. The load and positioning of the load in the vehicle are listed in Table 3.

In addition to water dummies, the loading included instrumentation, a steering machine, and outriggers. Test vehicle bumper assemblies were removed for outrigger installation. The reduction in vehicle weight due to the removal of the bumpers was offset by the additional weight of the outriggers and their mounting system. The outrigger system typically outweighs the bumper assemblies.

Table 1. Test Vehicle Data

General Data					
Model year, make, model	2019 Jeep Wrangler Unlimited 4WD				
VIN	1C4HJXEG5KW53xxxx				
Body style	MPV				
Number of doors	4				
Trim level	LIMITED SAHARA				
Seating positions	Front:	2 nd row	3 rd row	4 th row	5 th row
	2	3	0	0	0
Electronic stability control	Yes				
4-Wheel ABS (Yes/No)	Yes				
Power steering (Yes/No)	Yes				
Major optional equipment	Leather-Trimmed Seats w/ Sahara Logo, LED Lighting Group, 8.4-Inch Radio and Premium Audio Group, Jeep Active Safety Group, Hard Top Headliner, Cargo Tub Liner by Mopar, Plastic Door Sill Guards by Mopar, All-Weather Floor Mats, 8-Speed Automatic Transmission, 2.72:1 Selec-Trac Full-Time 4WD System, Anti-Spin Differential Rear Axle, Remote Proximity Keyless Entry, Body-Color 3-Piece Hard Top, Remote-Start System, Jeep Trail Rated Kit.				
Odometer at start of testing	39 miles				
Drivetrain					
Engine cylinder arrangement	V-6				
Engine displacement	3.6 L				
Transmission type	Automatic				
Drive arrangement	4WD				
Chassis					
Track width	F: 63 in (1600.2 mm) , R: 63 in (1600.2 mm)				
Wheelbase	118.25 in (3003.5 mm)				
Curb weight	4448 lb (2017.6 kg)				
Certification Data from Vehicle's Label					
Vehicle manufactured by	FCA US LLC				
Date of manufacture	1-19				

GVWR	5500 lb (2495 kg)
GAWR Front	2700 lb (1225 kg)
GAWR Rear	3000 lb (1361 kg)

Table 2. Tire Information

Tire Manufacturer	Bridgestone
Tire Model	Dueler A/T
Tire Size	Front: 255/70R18 Rear: 255/70R18
Load rating	Front: 113 Rear: 113
Speed rating	Front: T Rear: T
Treadwear grade	Front: 400 Rear: 400
Traction grade	Front: B Rear: B
Temperature grade	Front: B Rear: B
Location of "Recommended Tire Pressure" label	Driver's door jamb
Recommended cold tire pressure	Front: 36 psi, (250 kPa) Rear: 36 psi, (250 kPa)
First 8 digits of DOT code	Front: 9BXJ RHD Rear: 9BXJ RHD

Table 3. Vehicle Loading

Water dummy and other loading	3 water dummies in second row
Water dummy weight	175 lb (79.4 kg)
Fuel level	Full
Weight as Tested	
Left front	1281 lb (581.1 kg)
Right front	1322 lb (599.6 kg)
Left rear	1414 lb (641.4 kg)
Right rear	1449 lb (657.3 kg)

D. STEERING CONTROLLER

Precise controlled steering is accomplished using a steering machine designed and constructed by DRI. DRI has used its Automated Vehicle Controller (AVC) steering machine for many vehicle tests including FMVSS 126 tests. It can provide up to 65 ft-lb torque and rates over 1300 deg/sec. The integrated angle encoder has an unlimited range with a resolution of 0.045 degrees and an accuracy of ± 0.045 degrees. The steering motor is controlled by a MicroAutoBox II from dSPACE which also acts as the data acquisition system.

E. REAL-TIME CONTROLLER AND DATA ACQUISITION

Data acquisition is achieved using a MicroAutoBox II from dSPACE which also serves as the real-time system for the steering controller. Data from the Oxford IMU, including Longitudinal, Lateral, and Vertical Acceleration, Roll, Yaw, and Pitch Rate, Forward and Lateral Velocity, Roll and Pitch Angle are sent over Ethernet to the Micro AutoBox. The Oxford IMUs are calibrated per the manufacturer's recommended schedule (Table 5). The MicroAutoBox II specifications are:

Model: D-Space Micro-Autobox II 1401/1513
Base Board SN 549068
I/O Board SN 588523

Two video cameras were used to record the Fishhook runs. They were positioned nominally as shown in Figure 1. The recorded videotapes were reviewed after the Fishhook runs to check for any two wheel lift. If any two wheel lift was observed, eight infrared distance measuring sensors for measurement of wheel lift (two sensors at each wheel) were then mounted for use in subsequent confirmation Fishhook tests.

F. EQUIPMENT WEIGHT

F. Equipment Weight

Table 4 lists the equipment and associated weights outlined in the NHTSA Laboratory Test Procedure for Dynamic Rollover and the equipment at DRI used for this specific test program. The equipment used at DRI for this test program differs slightly from the equipment that was previously used by NHTSA for rollover testing. Because DRI's equipment is lighter than NHTSA's equipment, DRI uses ballast to maintain a consistent weight and weight distribution in the vehicle.

Table 4. Weight of In-Cab Test Equipment

Equipment	Location	Equipment Weight (lb)	
		NHTSA*	DRI
Data Acquisition System	Front passenger seat	58	
Steering Machine	Handwheel	31	31
Steering Machine Electronics Box	Passenger row foot well behind the front passenger seat. If vehicle does not have a rear passenger row foot well, the Electronics Box should be placed in the front passenger seat foot well.	39	
MABX, and laptop	Front passenger seat		21
Motor control and power supply	Front passenger footwell		26
Ballast	Front passenger footwell		50
Total		128	128

* Table A.1 from US DOT NHTSA - Laboratory Test Procedure for Dynamic Rollover - The Fishhook Maneuver Test Procedure - New Car Assessment Program (NCAP) - March 2013

G. SENSORS

A list of the sensors is given in Table 5.

H. OTHER VEHICLE PREPARATION

In addition to installation and preparation discussed above, the test vehicle was prepared as follows:

- Front and rear bumpers were removed
- Outrigger mounts were installed in the bumper locations and titanium outriggers were fastened to these mounts
- Airbags were removed or otherwise disabled

Photographs of the vehicle tested are given in Appendix A.

Table 5. Sensors

Measured Variable	Sensor	Range	Resolution	Accuracy	Specifics	Serial Number	Calibration
Vehicle Tire Pressure	Tire Pressure Gauge	0-100 psi 0-690 kPa	0.01 psi 6.89 kPa	< 1% error between 20 and 100 psi	Omega DPG8001	17042707002	By: DRI Date: 6/21/2018 Due: 6/21/2019
Vehicle Total, Wheel, and Axle Load	Platform Scales (Minter)	1200 lb/platform 5338 N/platform	1 lb 4.4 N	0.5% of applied load	Intercomp SWI	1110M206352	By: DRI Date: 1/3/2019 Due: 1/3/2020
	Platform Scales (Torrance)	1500 lb/platform 6672 N/platform	1 lb 4.4 N	0.5% of applied load	Intercomp SWI	24032361	By: DRI Date: 12/11/2018 Due: 12/11/2019
Handwheel Angle	Steering Angle Encoder (Automated Steering Controller)	±800 deg	0.045 deg	±0.045 deg	DRI Automatic Vehicle Controller using D-Space Micro- Autobox II	NA	Verified by DRI at installation ¹
Longitudinal, Lateral, and Vertical Acceleration Roll, Yaw, and Pitch Rate, Forward and Lateral Velocity, Roll and Pitch Angle	Multi-Axis Inertial Sensing System	Accels ± 5 g, Angular Rate ±300 deg/s, Angle >45 deg, Velocity >200 km/h	Accels .001 g, Angular Rate 0.01 deg/s, Angle 0.05 deg, Velocity 0.1 km/h	Accels .001g, Angular Rate 0.01 deg/s, Angle 0.05 deg, Velocity 0.1 km/h	Oxford xNav 550	015360	By: Oxford Technical Solutions Date: 6/21/2017 Due: 6/21/2019

1 . The steering encoder is checked prior to beginning tests to verify that there are no faults. The steering controller is installed in the vehicle and the steering wheel is turned through two complete revolutions while recording data. The data are then reviewed for any dropouts or other nonlinearities that would indicate dust intrusion or faulty sectors.

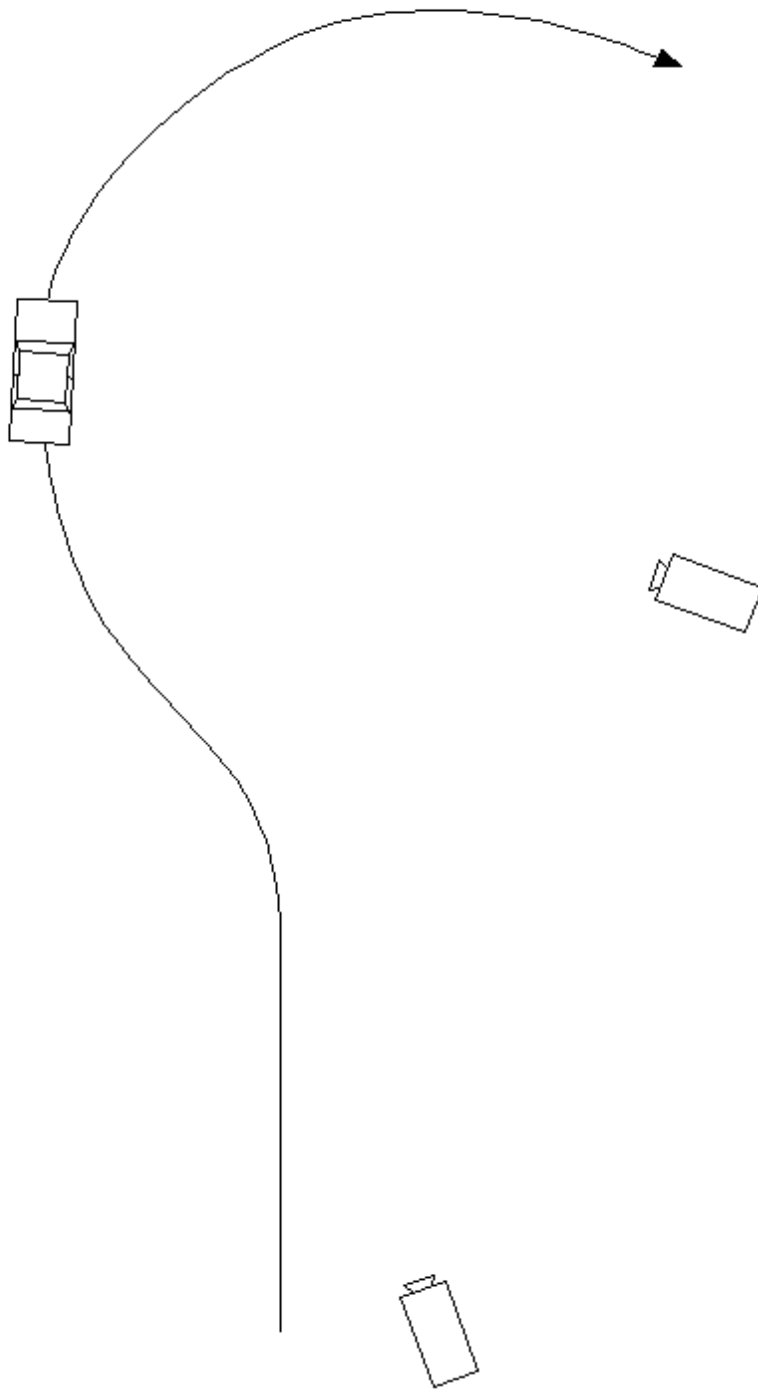

Figure 1. Nominal Position of Video Cameras for Fishhook Tests

Section III TEST PROCEDURES

This section includes a general overview of the test procedures and details of the particular test.

A. TEST PROCEDURE OVERVIEW

This test was conducted in accordance with NHTSA's NCAP Rollover Resistance Test Procedure (Fishhook) as described in the Federal Register (68 FR 59250). Detailed descriptions of the test procedure, pass/fail criteria, and data acquisition specifications may be found at docket NHTSA-2001-9663.

There are two major components of the test procedure, the Slowly Increasing Steer (SIS) pre-test and the Fishhook test.

The Slowly Increasing Steer (SIS) maneuver was used to characterize the steady state lateral dynamics of each vehicle, and is based on the "Constant Speed, Variable Steer" test defined in SAE J266. The maneuver is used to determine the handwheel angle that produces a lateral acceleration of 0.3 g at 50 mph. This handwheel angle is then used to determine the magnitude of steering to be used for the NHTSA Fishhook maneuver.

SIS tests were performed at a constant speed of 50 mph. Handwheel angle was input at a rate of 13.5 deg/sec, from 0 to an angle that provided at least 0.55 g. Three tests were conducted in each direction, and the data for the six runs were averaged to obtain the handwheel angle that produced 0.3 g at 50 mph.

The Fishhook test is a programmed steering maneuver that is implemented via the steering controller. The vehicle was initially steered in one direction and then the steering was reversed. The timing, magnitude and rate of the steering were prescribed by the Fishhook Procedure.

To begin the maneuver, the vehicle was driven in a straight line at a speed slightly greater than the desired entrance speed. The driver then released the throttle. When the vehicle was at the target speed, the steering controller automatically initiated the steering maneuver. Following completion of the steering reversal the handwheel position was maintained for three seconds, and then returned to zero angle in 1 second.

The tests were conducted in both left-right and right-left directions. The “Default” test series used a handwheel angle equal to 6.5 times the handwheel angle that produced 0.3 g at 50 mph in the SIS tests, and initial vehicle speeds beginning at 35 mph and concluding up to 50 mph (if no two-wheel lift occurs). Supplemental tests were also done, as specified in the Fishhook Procedure.

B. TEST CONDITIONS

1. Test Surface

The tests were conducted on the Vehicle Dynamics Area at DRI’s Minter Field facility, located near Bakersfield, California, on 3/20/2019. The VDA has a smooth, flat (slope less than 0.5% throughout) asphaltic concrete surface. Its dimensions are as shown in Figure 2. It was built in the spring of 2005.

VDA surface friction measurements were accomplished using the DRI Mobile Tire Tester. Three runs were done, one at each of three previously determined locations. Each run provided for a minimum of 3 seconds of tire friction at constant normal load, slip angle, and speed in a free rolling condition. The test was accomplished using an ASTM E1136 tire with an inflation pressure of 35 (± 0.5) psi at a test speed of 40 (± 0.5) mph. The net slip angle of the test tire for each test run was 7.5 deg. The test tire was no older than 6 months from the date of manufacture. The surface friction measurement results are shown in Table 6.

Table 6. Surface Friction

Date of surface friction measurements	3/19/2019
Average normalized lateral force	0.826

2. Fishhook Handwheel Angles

The 0.3 g handwheel angle obtained from the SIS tests and the handwheel angles used in the Fishhook tests are shown in Table 7.

Table 7. Handwheel Angles

0.3 g handwheel angle (from SIS tests at 50 mph)	43.3°
5.5 scalar handwheel angle for Fishhook Test	238°
6.5 scalar handwheel angle for Fishhook Test	281°

3. Weather Conditions

The weather conditions, recorded at the end of testing, are shown in Table 8.

Table 8. Weather Conditions

Ambient temperature	48.2° F (9° C)
Wind Speed	0 mph (0 m/s)
Wind Direction	N/A

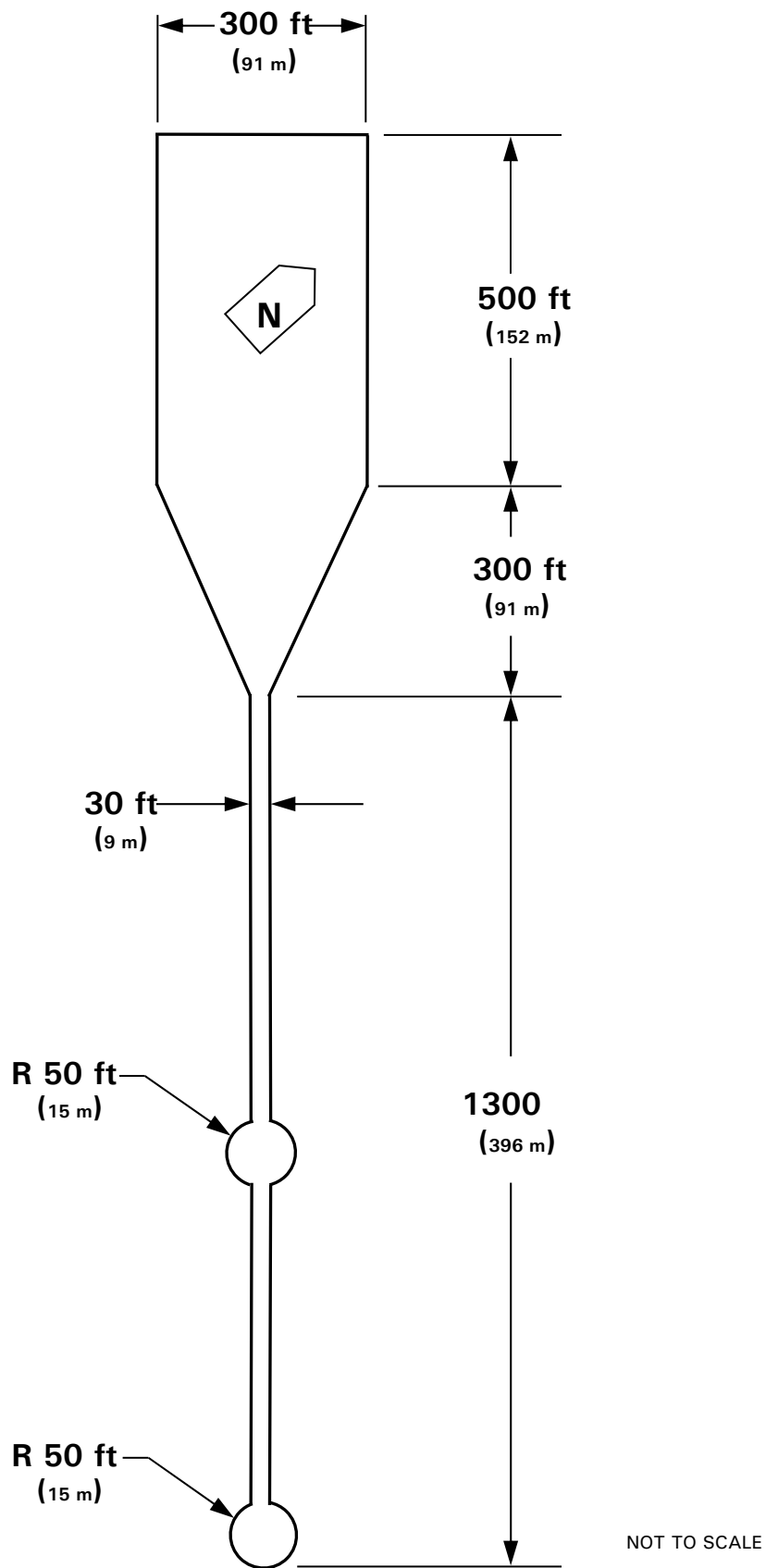

Figure 2. DRI-Minter Vehicle Dynamics Area

Section IV RESULTS

The test run log is given in Appendix B. The Slowly Increasing Steer Test Worksheet is given in Appendix C. Appendix D contains time history plots for the 50 mph runs and any runs which resulted in two-wheel lift. For the 2019 Jeep Wrangler Unlimited 4WD, there was no two-wheel lift at any test condition.

APPENDIX A

Photographs

LIST OF FIGURES

	Page
A1. Window Sticker	A-3
A2. Front View, Test Vehicle as Delivered	A-4
A3. Rear View, Test Vehicle as Delivered	A-5
A4. Front View, Test Vehicle in Test Condition	A-6
A5. Rear View, Test Vehicle in Test Condition	A-7
A6. Instrumentation in Test Vehicle	A-8
A7. Steering Controller and Computer	A-9
A8. Ballast Condition.....	A-10



2019 MODEL YEAR
WRANGLER UNLIMITED SAHARA 4X4

For more information visit: www.jeep.com
or call 1-877-IAM-JEEP

FCA US LLC

THIS VEHICLE IS MANUFACTURED TO MEET SPECIFIC UNITED STATES REQUIREMENTS. THIS VEHICLE IS NOT MANUFACTURED FOR SALE OR REGISTRATION OUTSIDE OF THE UNITED STATES.

MANUFACTURER'S SUGGESTED RETAIL PRICE OF THIS MODEL INCLUDING DEALER PREPARATION

Base Price: \$38,395

JEEP WRANGLER UNLIMITED SAHARA
Exterior Color: Bright White Clear-Coat Exterior Paint
Interior Color: Black Interior Color
Interior: Leather-Trimmed Seats w/ Sahara Logo
Engine: 3.6L V6 24V VVT Engine Upp I w/ESS
Transmission: 8-Speed Automatic Transmission

STANDARD EQUIPMENT (UNLESS REPLACED BY OPTIONAL EQUIPMENT)
FUNCTIONAL/SAFETY FEATURES
Advanced Multistage Front Air Bags
Supplemental Front Side Air Bags
ParkView® Rear Back-Up Camera
Command-Trac Part-Time 4WD System
3.45 Axle Gear Ratio
3rd Generation Dana® 44 HD Rear Axle
Heavy-Duty Suspension with Gas Shocks
Fuel Tank Skid Plate Shield
Transfer Case Skid Plate Shield
Transmission Skid Plate
Jeep® Tool Kit
Anti-Lock 4-Wheel Disc Heavy-Duty Brakes
Electronic Stability Control
Electronic Roll Mitigation
Trailer Sway Damping
Remote Keyless Entry
Security Alarm
Universal Garage-Door Opener

INTERIOR FEATURES

Uconnect® 4 with 7-Inch Display
Cluster 7.0-Inch TFT Color Display
Apple CarPlay®
Google Android Auto™
SiriusXM® Sat Radio w/ 1-Yr Radio Subscription
For More Info, Call 800-643-2112
8-Speakers
Media Hub (USB, Aux)
Integrated Voice Command with Bluetooth®
115V Power Outlet

OPTIONAL EQUIPMENT (May Replace Standard Equipment)

Leather-Trimmed Seats w/ Sahara Logo Leather-Wrapped Park Brake Handle Leather-Wrapped Shift Knob Premium Wrapped Instrument Panel Bezels	\$1,495
Customer Preferred Package 24G LED Lighting Group LED Reflector Headlamps Front LED Fog Lamps LED Tail Lamps LED Daytime Running Accent Lamps 8.4-Inch Radio and Premium Audio Group Uconnect® 4C NAV with 8.4-Inch Display GPS Navigation	\$995
	\$1,595

Alpine® 9-Speaker Premium Audio System Auto-Dimming Rear View Mirror Emergency / Assistance Call HD™ Radio 1-Year SiriusXM® Guardian Service 5-Year SiriusXM® Traffic Service 5-Year SiriusXM® Travel Link Service SiriusXM® Traffic Plus Jeep® Active Safety Group ParkSense® Rear Park-Assist System Blind-Spot and Cross-Path Detection Hard Top Headliner	\$895
Cargo Tub Liner by Mopar® Plastic Door Sill Guards by Mopar® All-Weather Floor Mats 8-Speed Automatic Transmission 3rd Generation Dana® Solid Rear Axle Hill Descent Control	\$525
Tip Start 2.7/2.1 Selec-Trac® Full-Time 4WD System Anti-Spin Differential Rear Axle 255/70R18 All-Terrain Tires Remote Proximity Keyless Entry Body-Color 3-Piece Hard Top Delete Soft Top Rear Window Wiper / Washer Rear Window Defroster Freedom Panel Storage Bag	\$495
Remote-Start System (N/A w/Manual Transmission) Jeep Trail Rated Kit	\$195
	\$1,495

DESTINATION CHARGE \$1,495

TOTAL PRICE: *\$52,275

WARRANTY COVERAGE
5-year or 60,000-mile Powertrain Limited Warranty,
3-year or 36,000-mile Basic Limited Warranty.
Ask Dealer for a copy of the limited warranties or see your owner's manual for details.

5 YEAR / 60,000 MILE
POWERTRAIN WARRANTY

EPA DOT Fuel Economy and Environment Gasoline Vehicle

Fuel Economy

20 MPG
combined city/hwy

5.0 gallons per 100 miles

These estimates reflect new EPA methods beginning with 2017 models.
Small SUV 4WD range from 18 to 120 MPG.
The best vehicle rates 136 MPG.

18 23
city highway

You spend \$2,500
more in fuel costs over 5 years compared to the average new vehicle.

Annual fuel cost \$1,900

Fuel Economy & Greenhouse Gas Rating (tailpipe only) Smog Rating (tailpipe only)

1 4 10
Best

1 5 10
Best

This vehicle emits 443 grams CO2 per mile. The best emits 0 grams per mile (tailpipe only). Producing and distributing fuel also creates emissions; learn more at fuelconomy.gov

Actual results will vary for many reasons, including driving conditions and how you drive and maintain your vehicle. The average new vehicle gets 27 MPG and cost \$7,900 to fuel over 5 years. Cost estimates are based on 15,000 miles per year at \$2.55 per gallon. MPGe is miles per gasoline gallon equivalent. Vehicle emissions are a significant cause of climate change and smog.

fuelconomy.gov
Calculate personalized estimates and compare vehicles

GOVERNMENT 5-STAR SAFETY RATINGS

This vehicle has not been rated by the government for frontal crash, side crash or rollover risk.

Source: National Highway Traffic Safety Administration (NHTSA)
www.safercar.gov or 1-888-327-4236

PARTS CONTENT INFORMATION
FOR VEHICLES IN THIS CARLINE:
U.S./CANADIAN PARTS CONTENT: 62%
MAJOR SOURCES OF FOREIGN PARTS CONTENT:
MEXICO: 21%
NOTE: PARTS CONTENT DOES NOT INCLUDE FINAL ASSEMBLY, DISTRIBUTION, OR OTHER NON-PARTS COSTS.
FOR THIS VEHICLE:
FINAL ASSEMBLY POINT:
TOLEDO, OHIO, U.S.A.
COUNTRY OF ORIGIN:
ENGINE: MEXICO
TRANSMISSION: UNITED STATES



Ask for Mopar Vehicle Protection for your vehicle. We Built It. We Back It.

Assembly Point/Port of Entry: TOLEDO, OHIO, U.S.A. SKIPTO GOLDTO

VIN: 1C4HJXEG5KW-53 LA-VIN: 8984 0108

THIS LABEL IS ADDED TO THIS VEHICLE TO COMPLY WITH FEDERAL LAW. THE LABEL CANNOT BE REMOVED OR ALTERED PRIOR TO DELIVERY TO THE ULTIMATE PURCHASER.
* STATE AND/OR LOCAL TAXES IF ANY, LICENSE AND TITLE FEES AND DEALER SUPPLIED AND INSTALLED OPTIONS AND ACCESSORIES ARE NOT INCLUDED IN THIS PRICE. DISCOUNT, IF ANY, IS BASED ON PRICE OF OPTIONS IF PURCHASED SEPARATELY.

Figure A1. Window Sticker



Figure A2. Front View, Test Vehicle as Delivered



Figure A3. Rear View, Test Vehicle as Delivered



Figure A4. Front View, Test Vehicle in Test Condition



Figure A5. Rear View, Test Vehicle in Test Condition



Figure A6. Instrumentation in Test Vehicle



Figure A7. Steering Controller and Computer



Figure A8. Ballast Condition

APPENDIX B

Test Run Log

Vehicle: **2019 Jeep Wrangler Unlimited 4WD**Driver: **JHR**Test Date: **3/20/2019**

Run Number	Test Type	Speed (mph)	Handwheel Angle (deg)	Dir. of First Steer	2 Wheel Lift	Notes
1	Tire Warm-Up	35	60	Right	NA	
2	"	"	80	"	"	
3	"	"	"	"	"	
4	"	"	"	"	"	
5	2x SWA last cycle					
6	Static	0	0			
7	Steady State	50	0			
8	Slowly Increasing Steer	50	60	Left	NA	
9	"	"	"	Left	"	
10	"	"	"	Left	"	
11	"	"	"	Right	"	
12	"	"	"	Right	"	
13	"	"	"	Right	"	
14	Fishhook 6.5 Scalar	35	281	Left	No	
15	"	40	"	"	"	
16	"	45	"	"	"	
17	"	47.5	"	"	"	
18	"	50	"	"	"	
19	Fishhook 5.5 Scalar	45	238	Left	No	
20	"	47.5	"	"	"	
21	"	50	"	"	"	

Vehicle: **2019 Jeep Wrangler Unlimited 4WD**Driver: **JHR**Test Date: **3/20/2019**

Run Number	Test Type	Speed (mph)	Handwheel Angle (deg)	Dir. of First Steer	2 Wheel Lift	Notes
22	Fishhook 6.5 Scalar	35	281	Right	No	
23	"	40	"	"	"	
24	"	45	"	"	"	
25	"	47.5	"	"	"	
26	"	50	"	"	"	
27	Fishhook 5.5 Scalar	45	238	Right	No	
28	"	47.5	"	"	"	
29	"	50	"	"	"	

APPENDIX C

Slowly Increasing Steer Test Worksheet

NCAP, 2019 Jeep Wrangler Unlimited 4WD , Multi-Passenger Load, Test Date: 3/20/2019

SIS_out_v2

Run	Dir of Steer	Start Speed (mph)	End Speed (mph)	Speed Red. (%)	Index of ay @ 0.3g	HW Angle (deg) at 0.3g	ay (g) @ 0.3g index	6.5x HW Angle (deg)	Ramp Time (sec) at 6.5x	5.5x HW Angle (deg)	Ramp Time (sec) at 5.5x	R2	Zero Begin Index	Zero End Index
8	L	49.0	4.9	90.0	1426	-41.8	-0.306	-271.8	-0.3774	-230.0	-0.3194	0.9959	600	800
9	L	50.5	-0.1	100.2	1426	-41.8	-0.305	-271.6	-0.3773	-229.8	-0.3192	0.9927	600	800
10	L	49.5	1.3	97.4	1428	-42.0	-0.297	-272.7	-0.3787	-230.7	-0.3205	0.9944	600	800
11	R	49.9	1.4	97.1	1464	44.4	0.298	288.8	0.4011	244.4	0.3394	0.9949	600	800
12	R	49.6	5.0	89.9	1466	44.5	0.310	289.0	0.4013	244.5	0.3396	0.9878	600	800
13	R	49.2	2.1	95.8	1475	45.2	0.293	293.6	0.4078	248.4	0.3451	0.9919	600	800

Mean: 43.3 0.301 281 0.391 238 0.331

Steering Controller Input Values

Scalar 6.5 values:

Initial HW angle: 281 deg
 Initial time: 0.391 s
 Reversal HW angle: -281 deg
 Reversal time: 0.781 s

Scalar 5.5 values:

Initial HW angle: 238 deg
 Initial time: 0.331 s
 Reversal HW angle: -238 deg
 Reversal time: 0.661 s

APPENDIX D

Time History Plots

LIST OF FIGURES

	Page
D1. Vehicle Speed, Handwheel Angle, and Roll Angle Time History Plots for Default Test Series, L-R, 50 mph	D-3
D2. Steering Machine Operation Time History Plots for Default Test Series, L-R, 50 mph.....	D-4
D3. Yaw Rate, Roll Rate, and Lateral Acceleration Time History Plots for Default Test Series, L-R, 50 mph	D-5
D4. Pitch Rate and Longitudinal Acceleration Time History Plots for Default Test Series, L-R, 50 mph	D-6
D5. Vehicle Speed, Handwheel Angle, and Roll Angle Time History Plots for Default Test Series, R-L, 50 mph	D-7
D6. Steering Machine Operation Time History Plots for Default Test Series, R-L, 50 mph	D-8
D7. Yaw Rate, Roll Rate, and Lateral Acceleration Time History Plots for Default Test Series, R-L, 50 mph	D-9
D8. Pitch Rate and Longitudinal Acceleration Time History Plots for Default Test Series, R-L, 50 mph	D-10
D9. Vehicle Speed, Handwheel Angle, and Roll Angle Time History Plots for Supplemental 2 Test Series, L-R, 50 mph.....	D-11
D10. Steering Machine Operation Time History Plots for Supplemental 2 Test Series, L-R, 50 mph	D-12
D11. Yaw Rate, Roll Rate, and Lateral Acceleration Time History Plots for Supplemental 2 Test Series, L-R, 50 mph	D-13
D12. Pitch Rate and Longitudinal Acceleration Time History Plots for Supplemental 2 Test Series, L-R, 50 mph	D-14
D13. Vehicle Speed, Handwheel Angle, and Roll Angle Time History Plots for Supplemental 2 Test Series, R-L, 50 mph.....	D-15
D14. Steering Machine Operation Time History Plots for Supplemental 2 Test Series, R-L, 50 mph	D-16
D15. Yaw Rate, Roll Rate, and Lateral Acceleration Time History Plots for Supplemental 2 Test Series, R-L, 50 mph	D-17
D16. Pitch Rate and Longitudinal Acceleration Time History Plots for Supplemental 2 Test Series, R-L, 50 mph	D-18

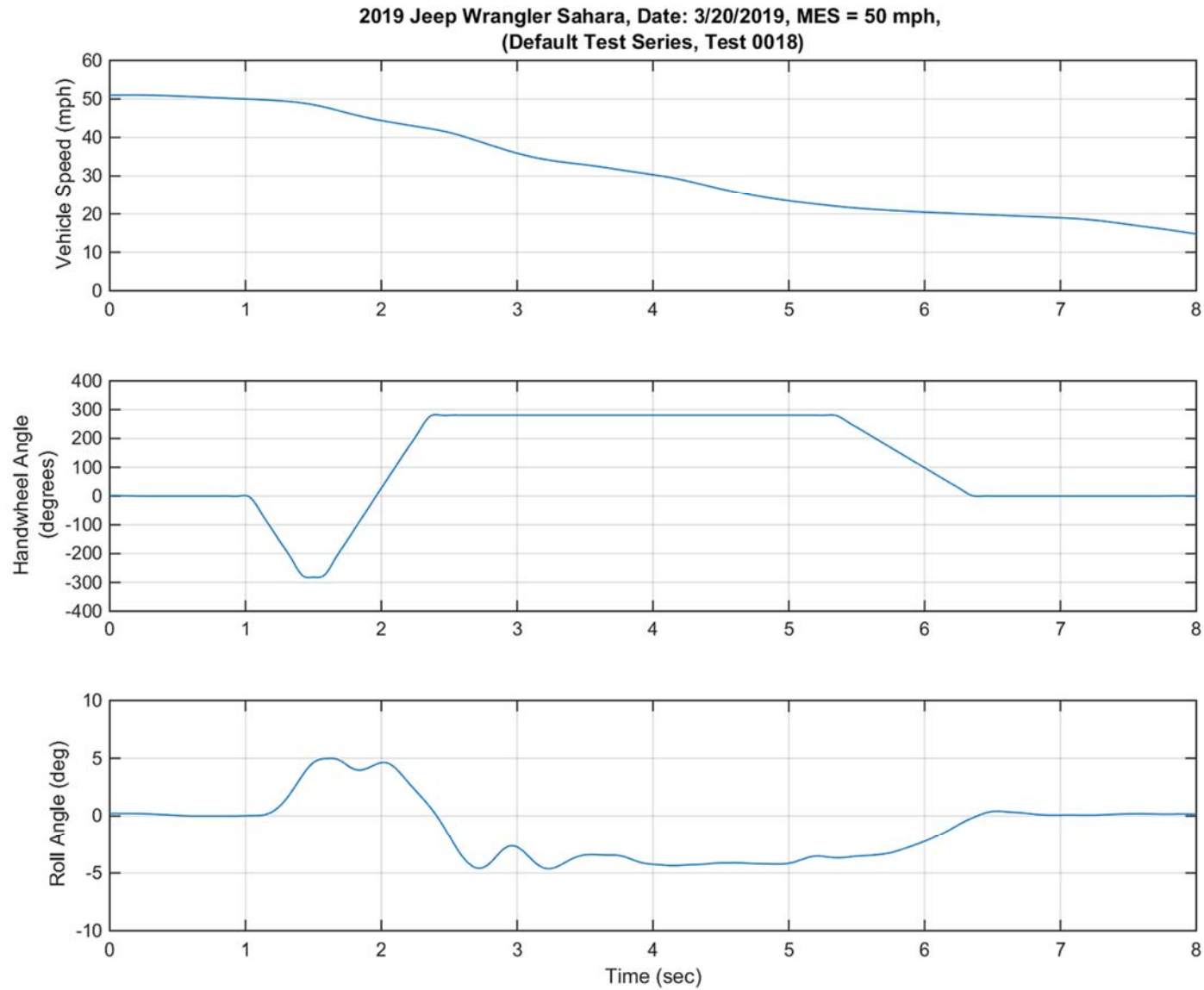

Figure D1. Vehicle Speed, Handwheel Angle, and Roll Angle Time History Plots for Default Test Series, L-R, 50 mph

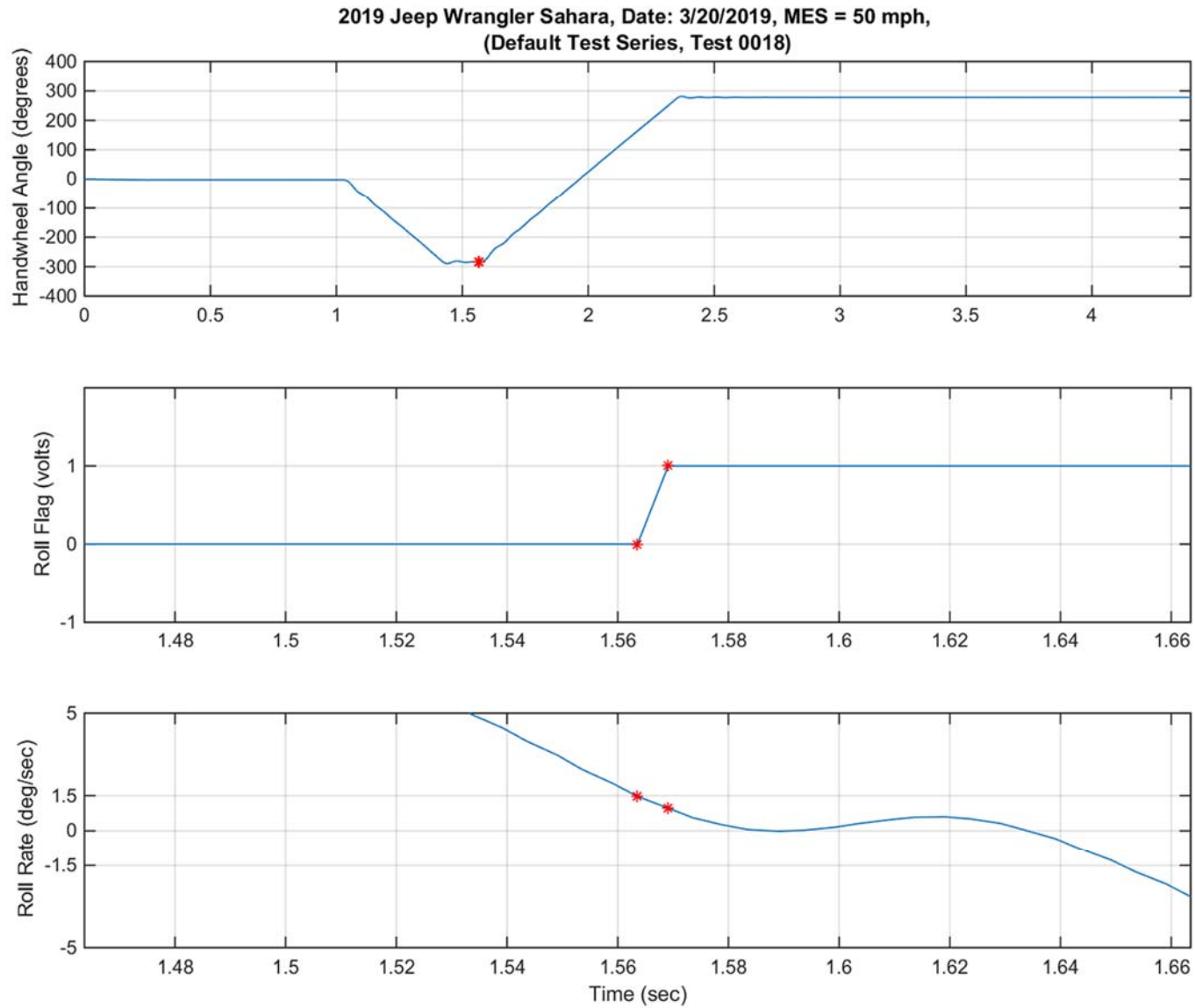

Figure D2. Steering Machine Operation Time History Plots for Default Test Series, L-R, 50 mph

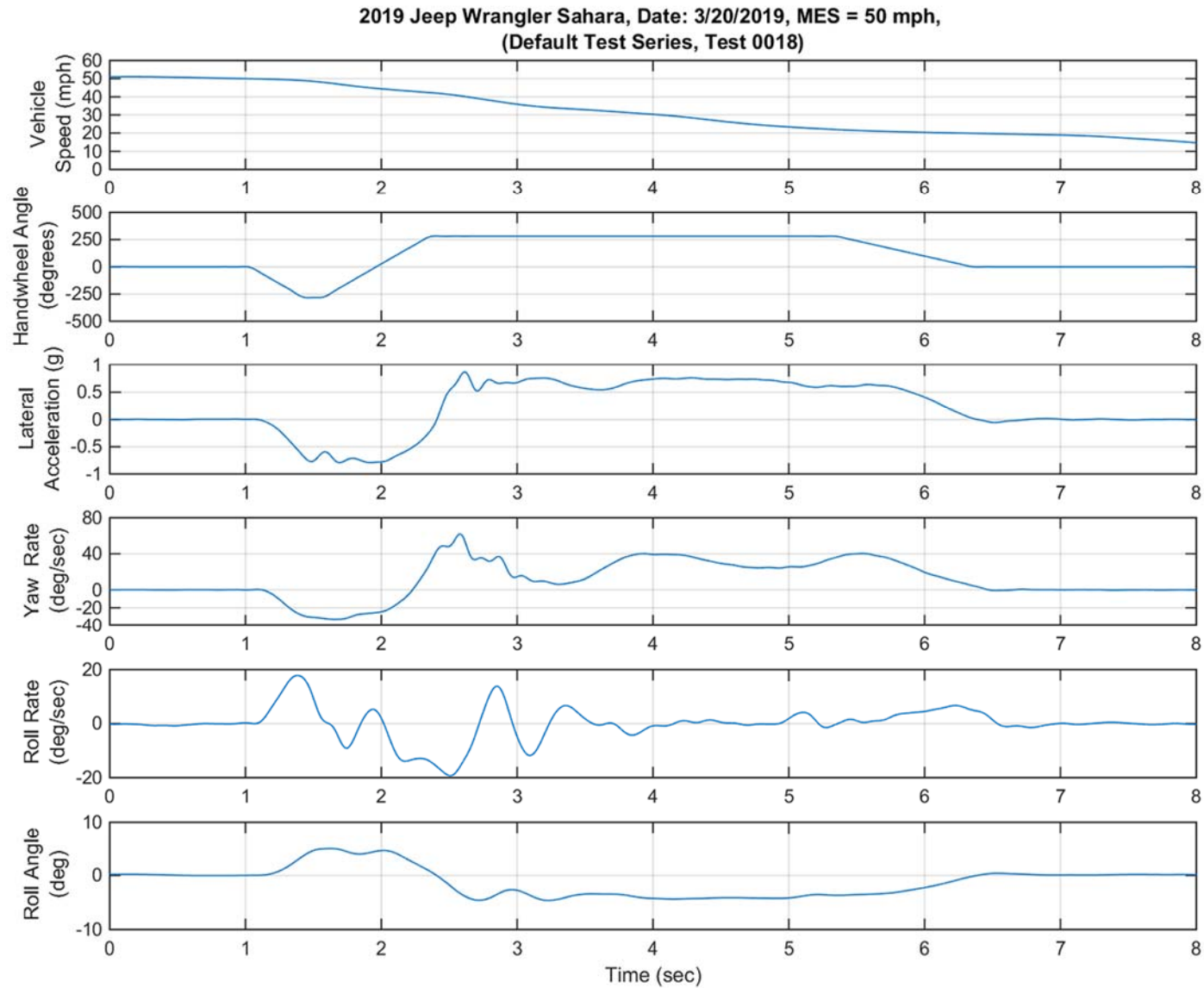

Figure D3. Yaw Rate, Roll Rate, and Lateral Acceleration Time History Plots For Default Test Series, L-R, 50 mph

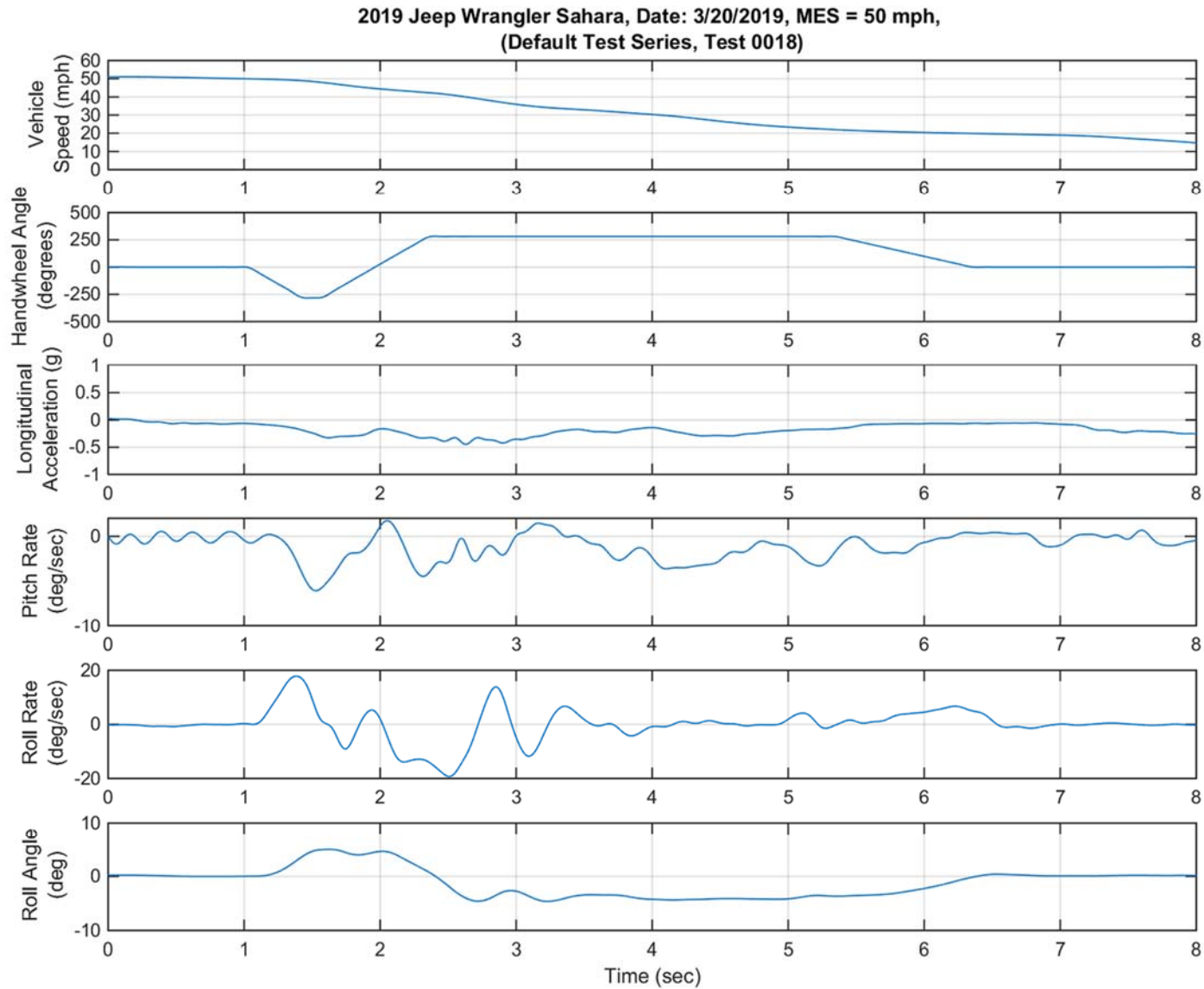

Figure D4. Pitch Rate and Longitudinal Acceleration Time History Plots for Default Test Series, L-R, 50 mph

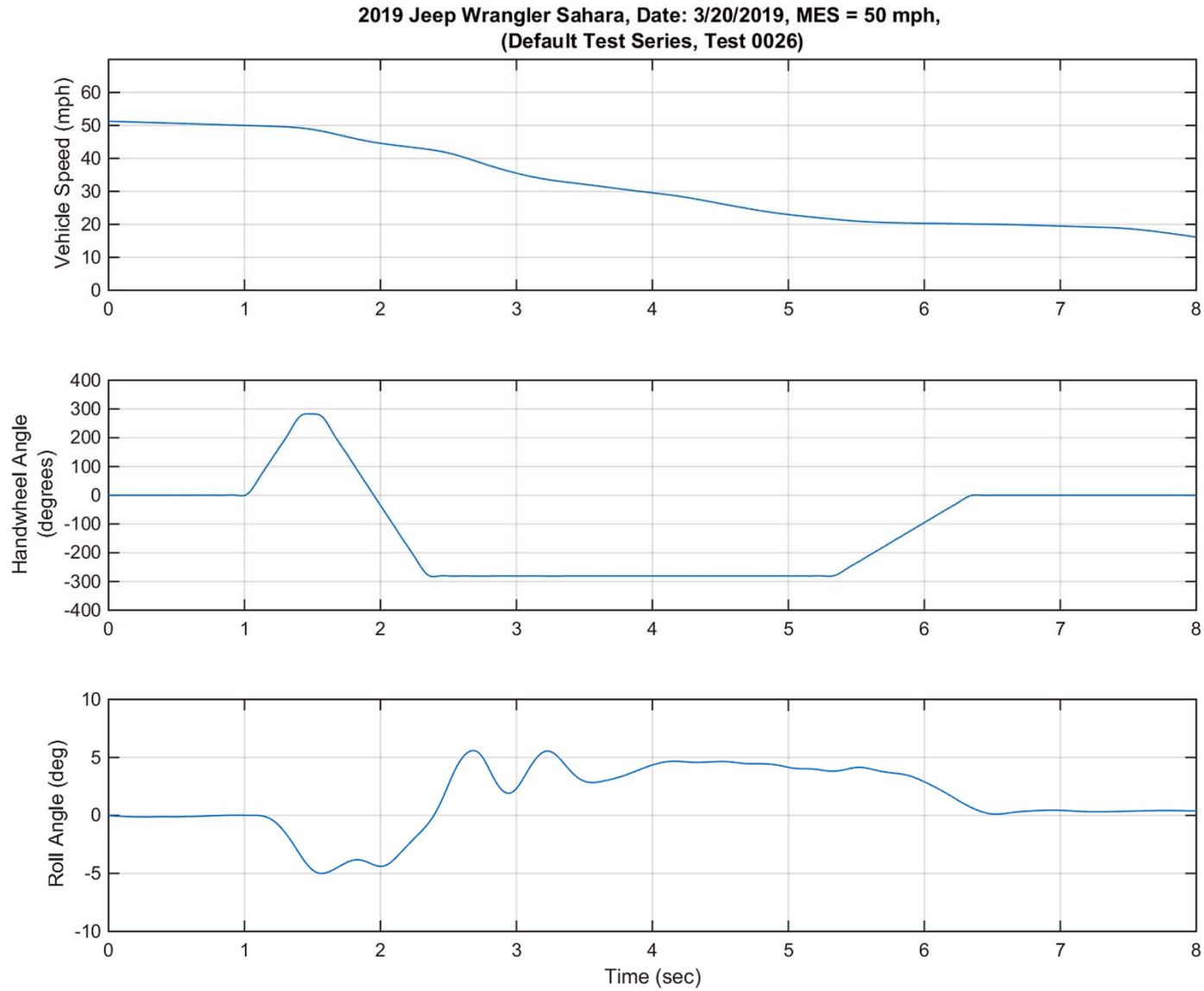

Figure D5. Vehicle Speed, Handwheel Angle, and Roll Angle Time History Plots for Default Test Series, R-L, 50 mph

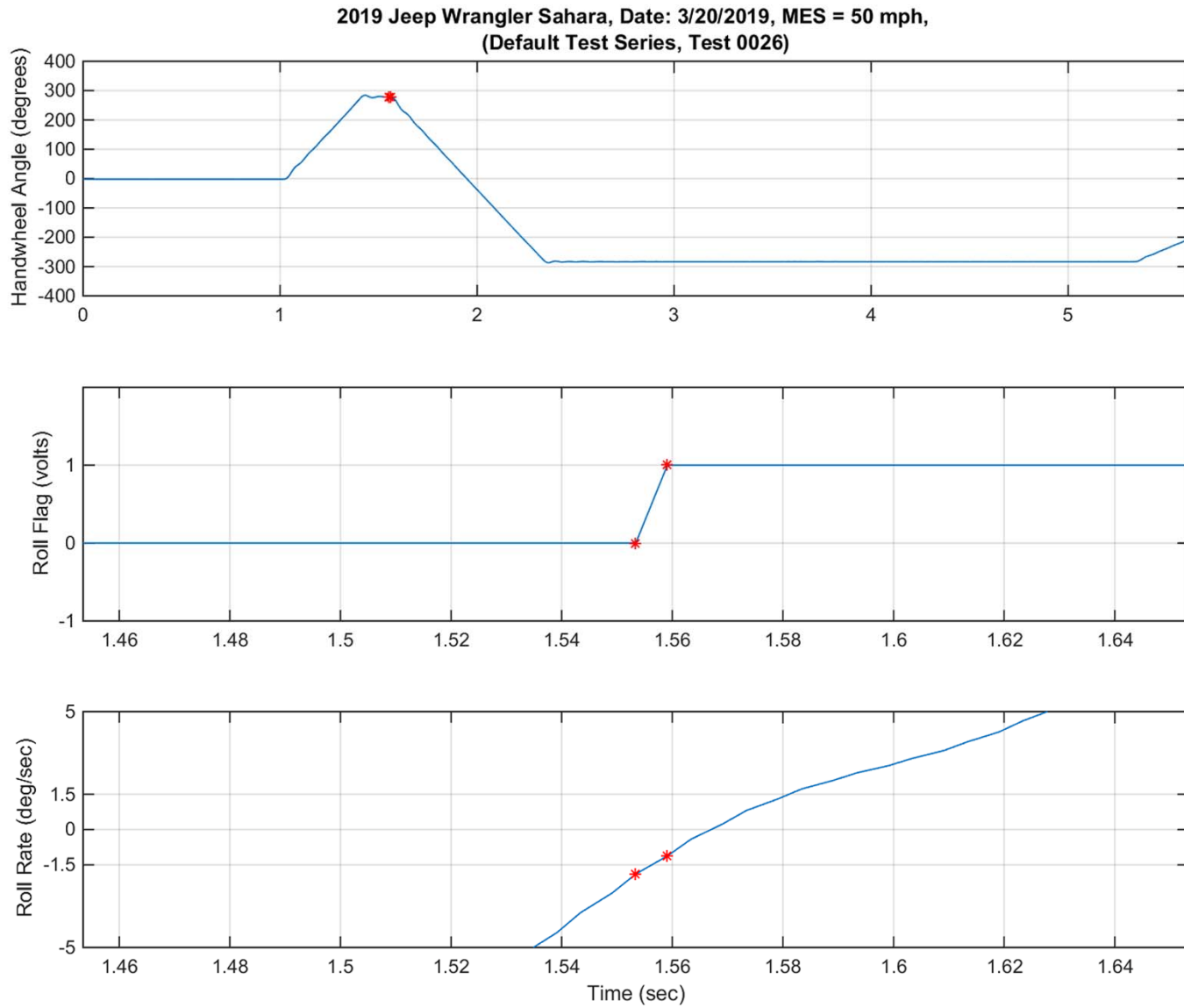

Figure D6. Steering Machine Operation Time History Plots for Default Test Series, R-L, 50 mph

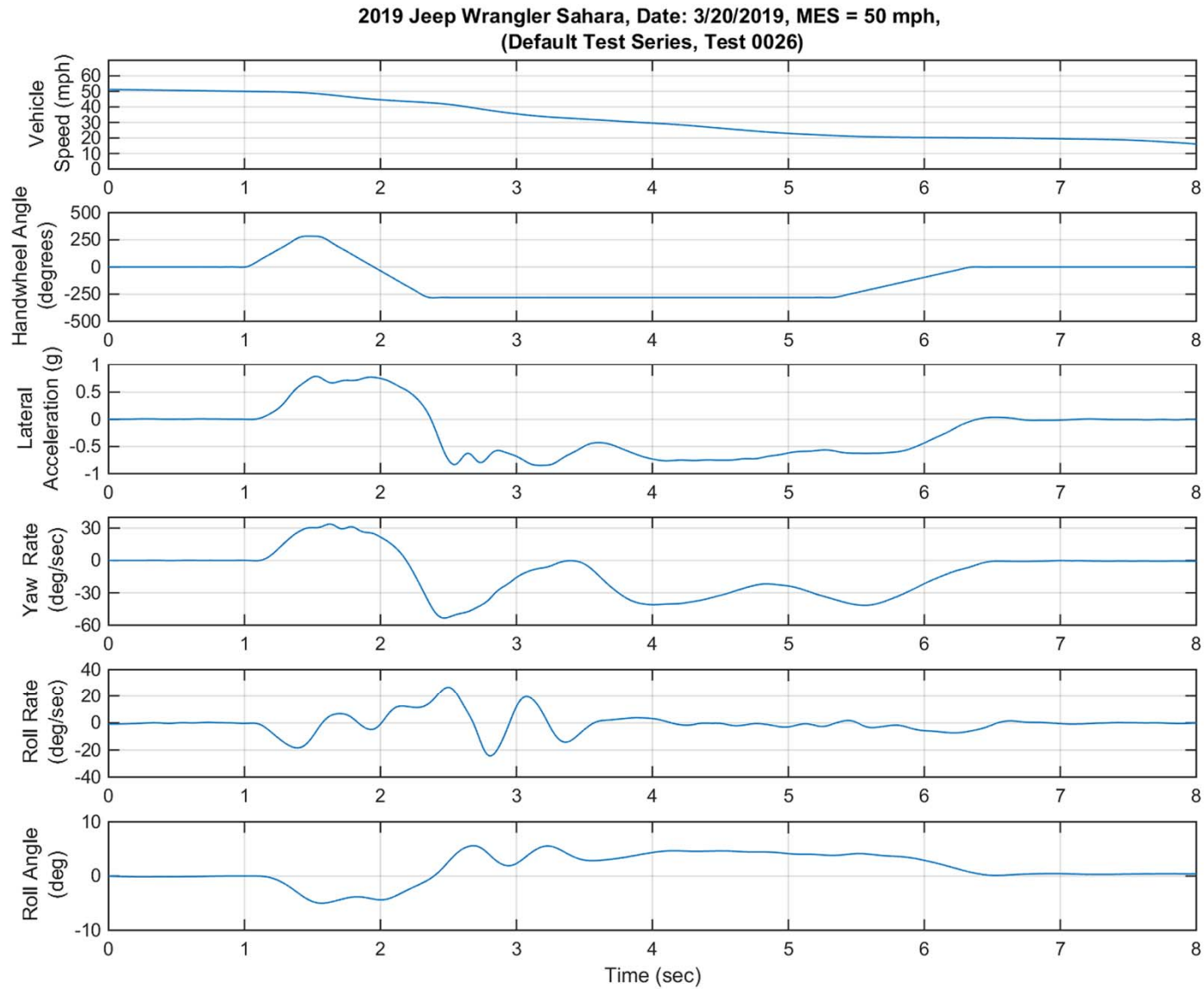

Figure D7. Yaw Rate, Roll Rate, and Lateral Acceleration Time History Plots for Default Test Series, R-L, 50 mph

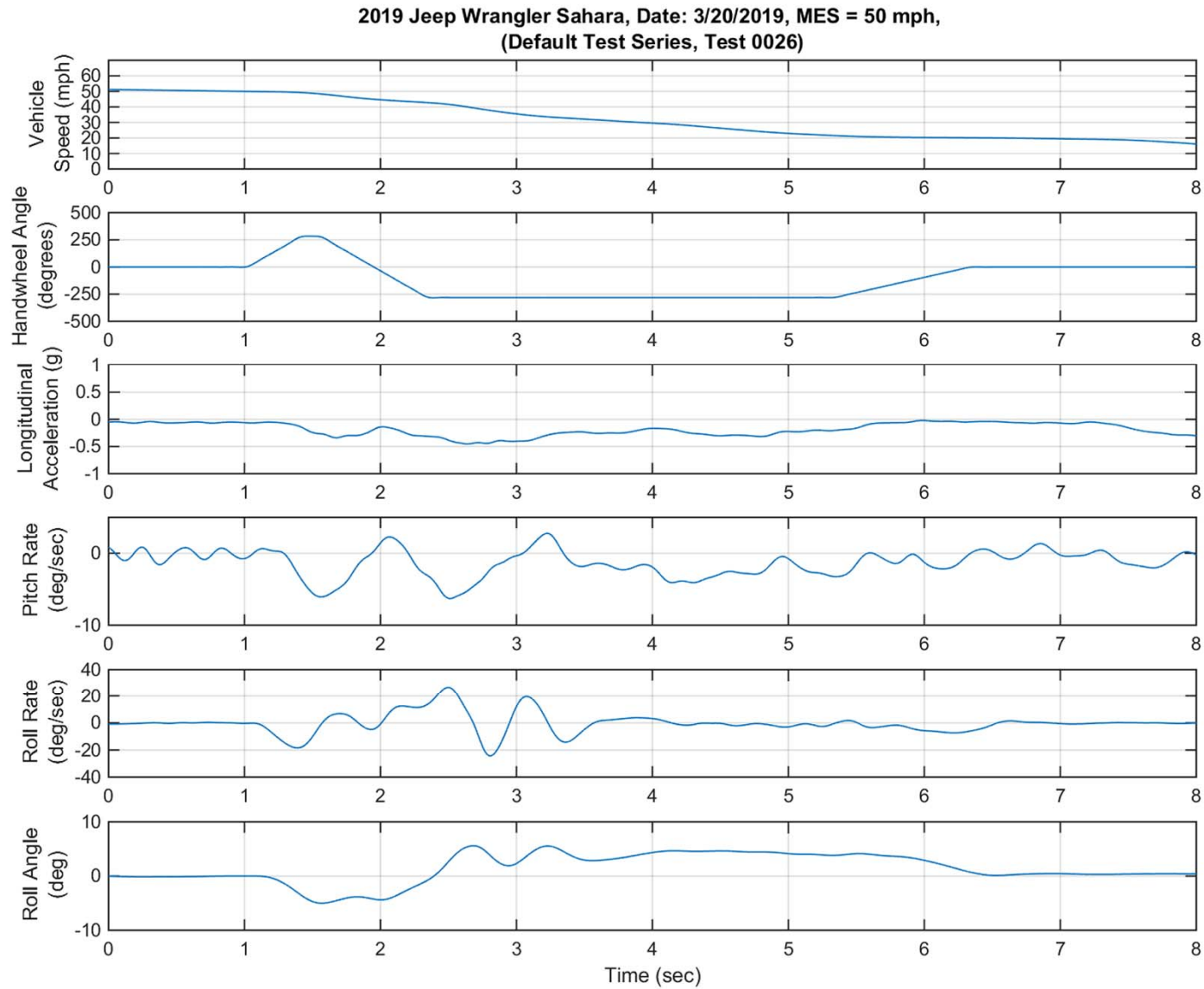

Figure D8. Pitch Rate and Longitudinal Acceleration Time History Plots or Default Test Series, R-L, 50 mph

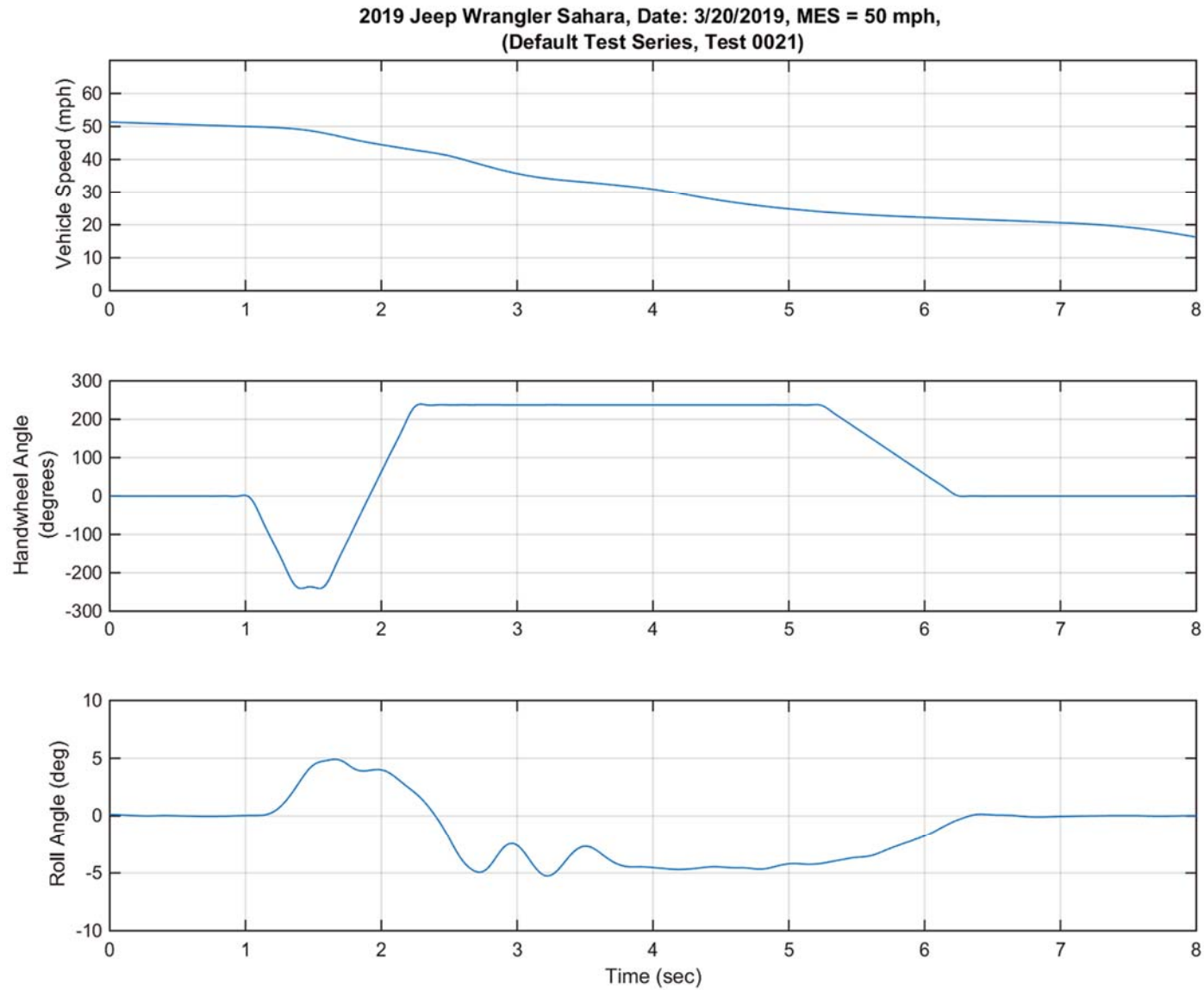

Figure D9. Vehicle Speed, Handwheel Angle, and Roll Angle Time History Plots for Supplemental 2 Test Series, L-R, 50 mph

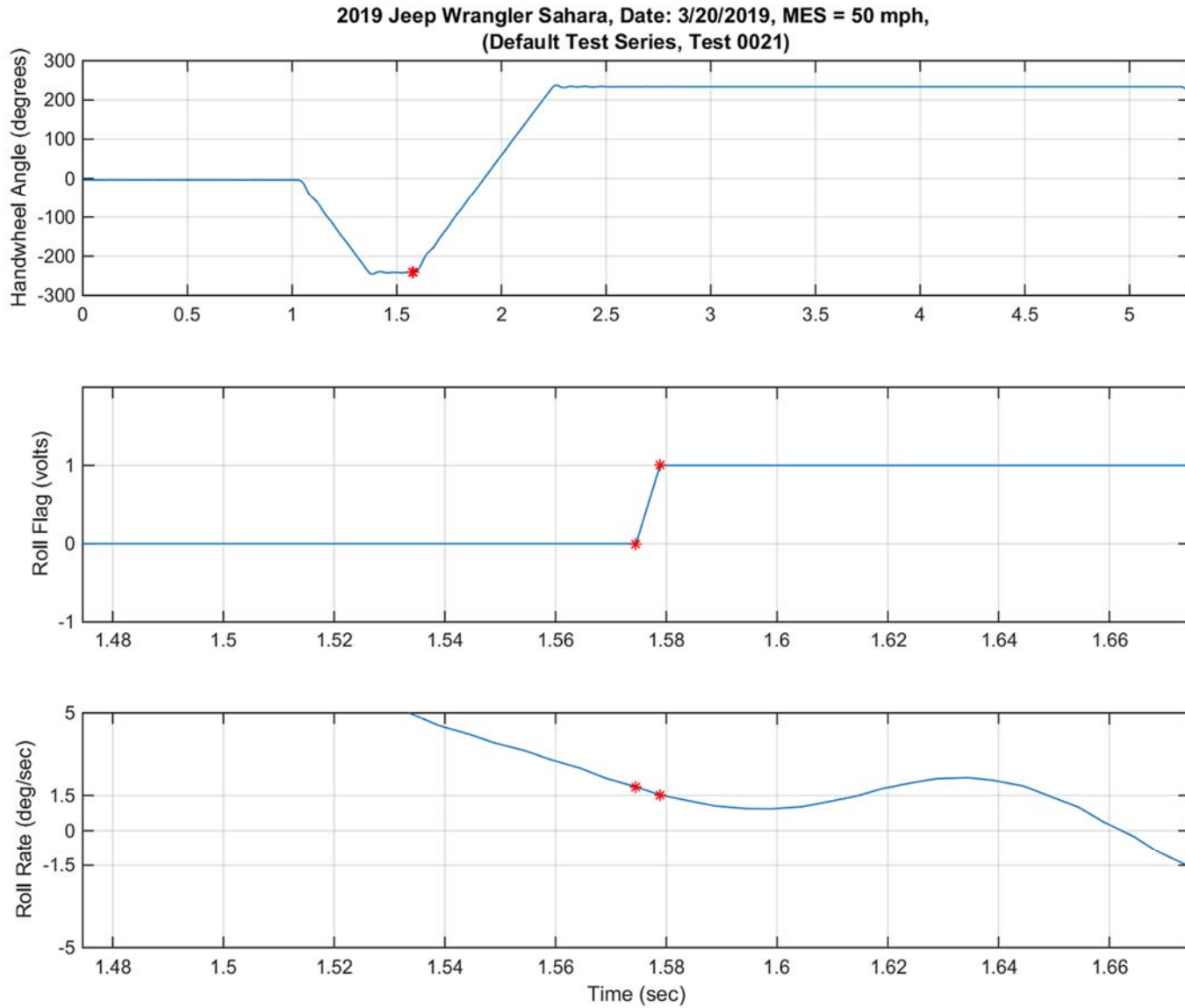

Figure D10. Steering Machine Operation Time History Plots for Supplemental 2 Test Series, L-R, 50 mph

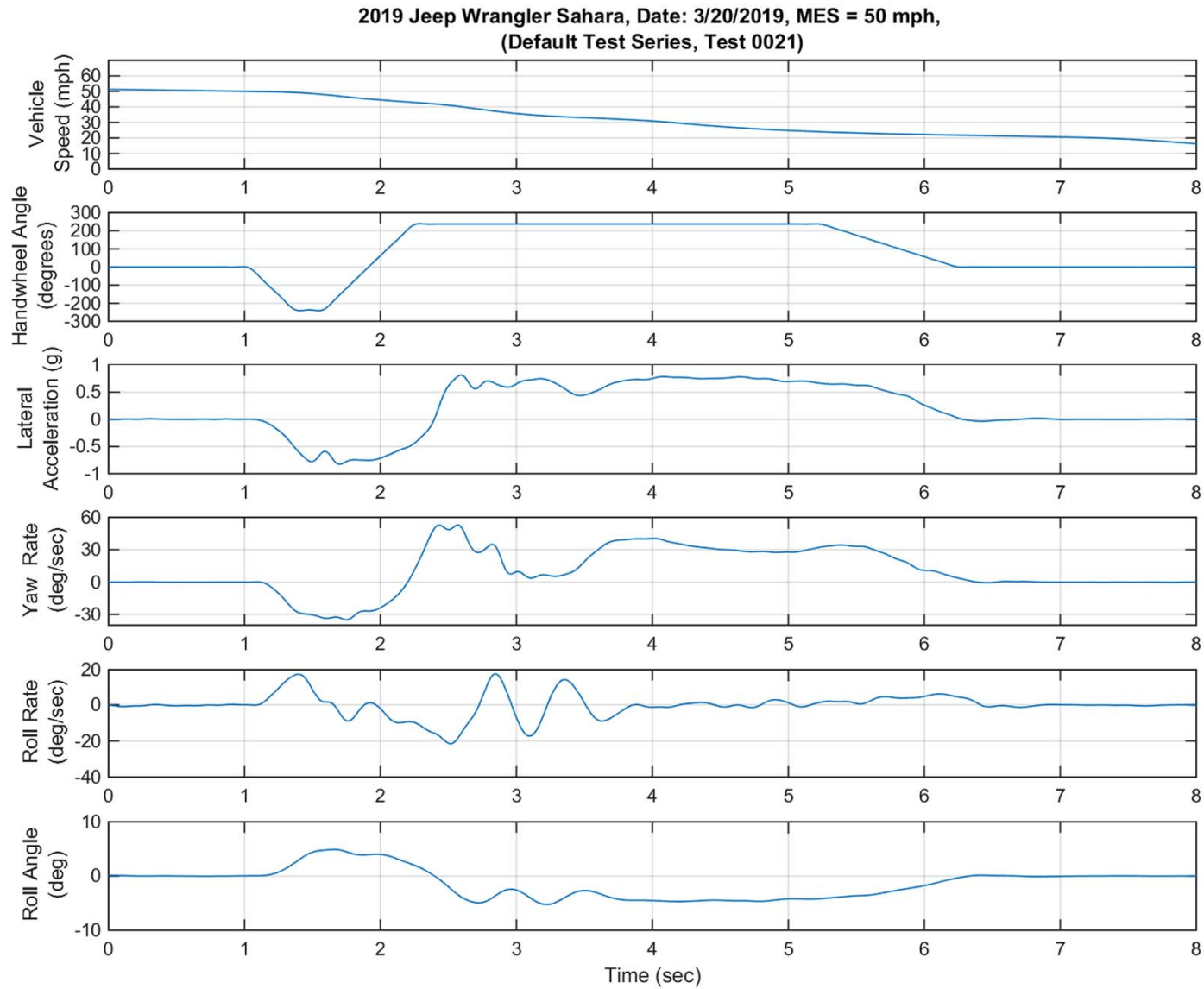

Figure D11. Yaw Rate, Roll Rate, and Lateral Acceleration Time History Plots for Supplemental 2 Test Series, L-R, 50 mph

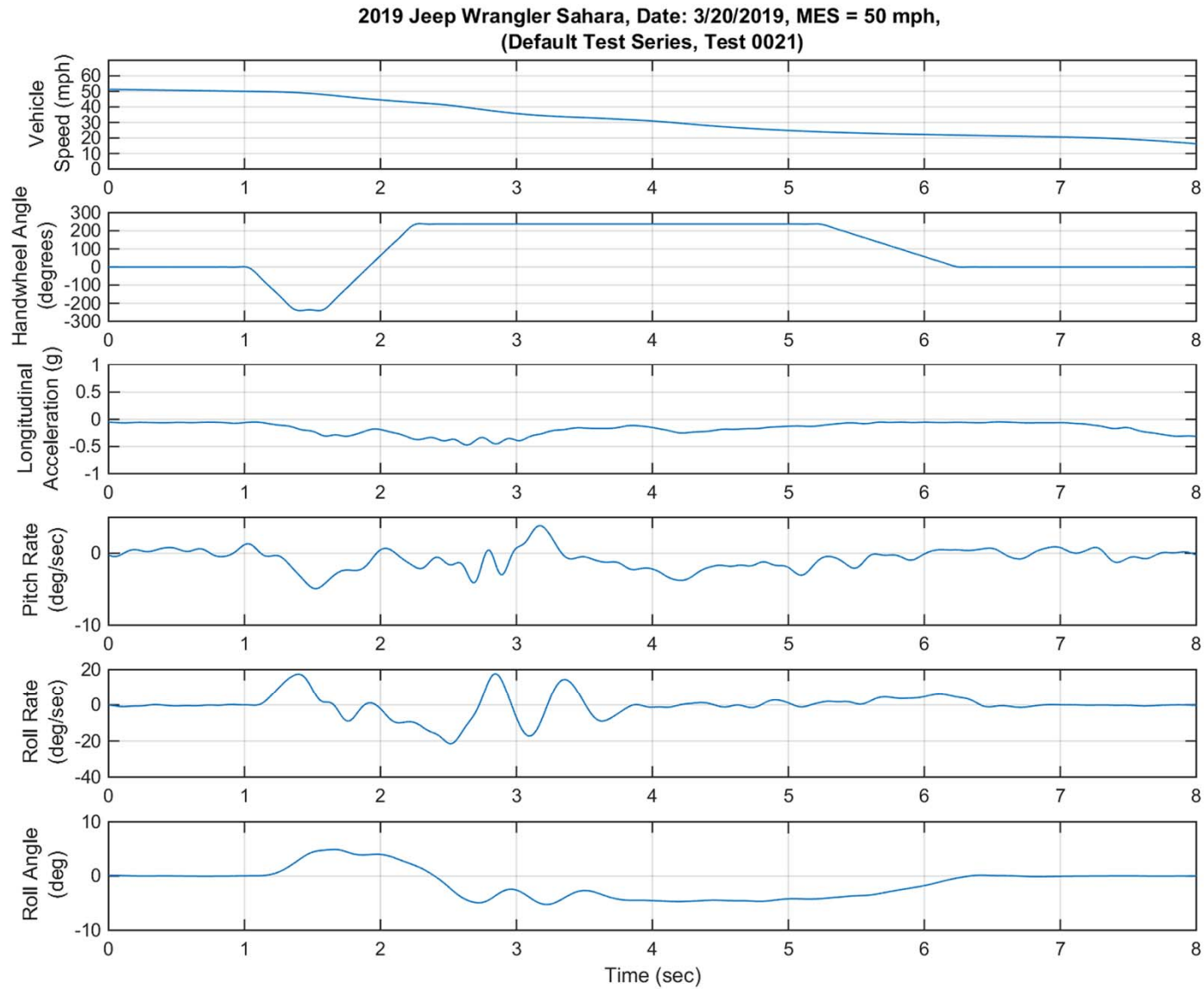

Figure D12. Pitch Rate and Longitudinal Acceleration Time History Plots for Supplemental 2 Test Series, L-R, 50 mph

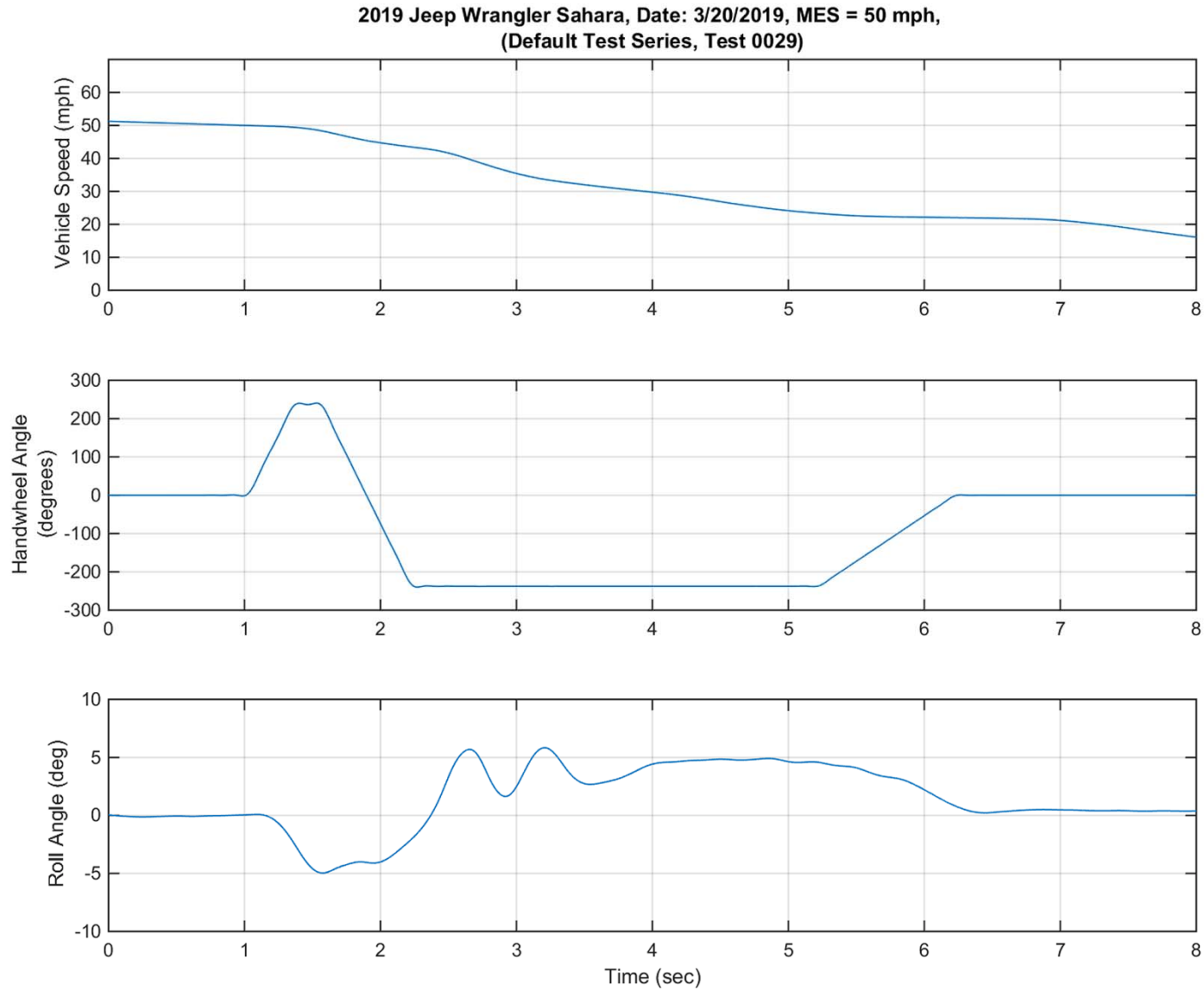

Figure D13. Vehicle Speed, Handwheel Angle, and Roll Angle Time History Plots for Supplemental 2 Test Series, R-L, 50 mph

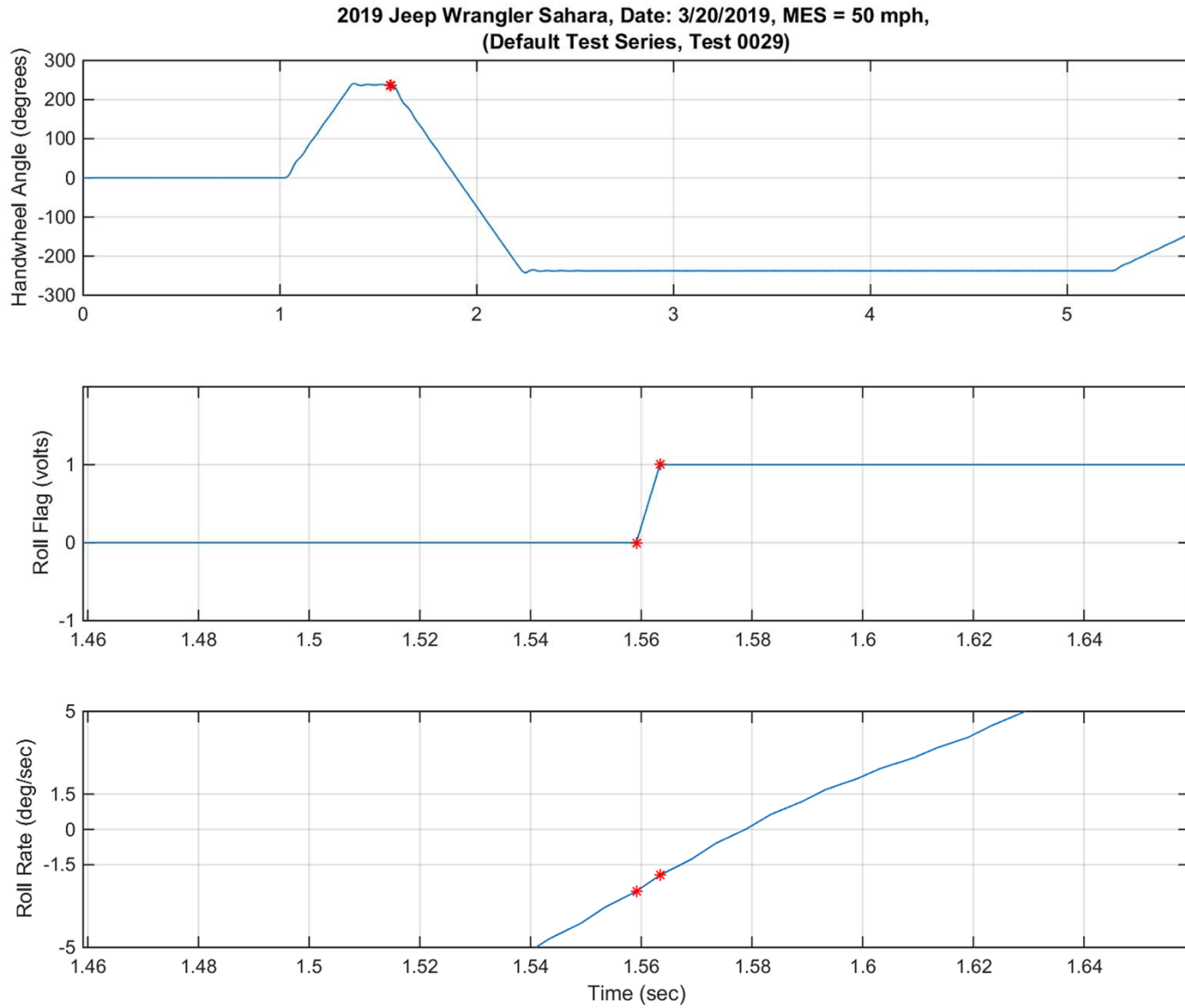

Figure D14. Steering Machine Operation Time History Plots for Supplemental 2 Test Series, R-L, 50 mph

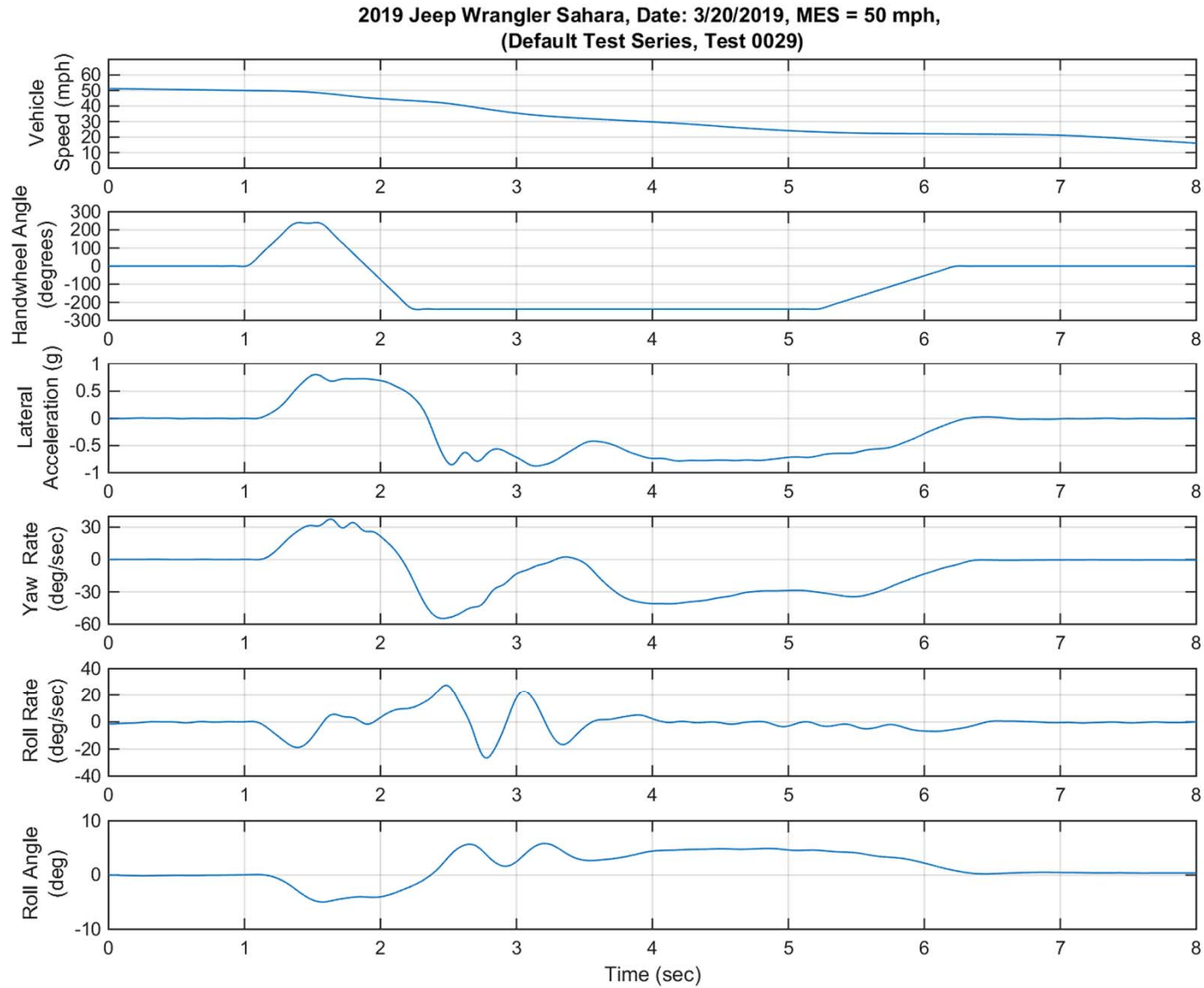

Figure D15. Yaw Rate, Roll Rate, and Lateral Acceleration Time History Plots for Supplemental 2 Test Series, R-L, 50 mph

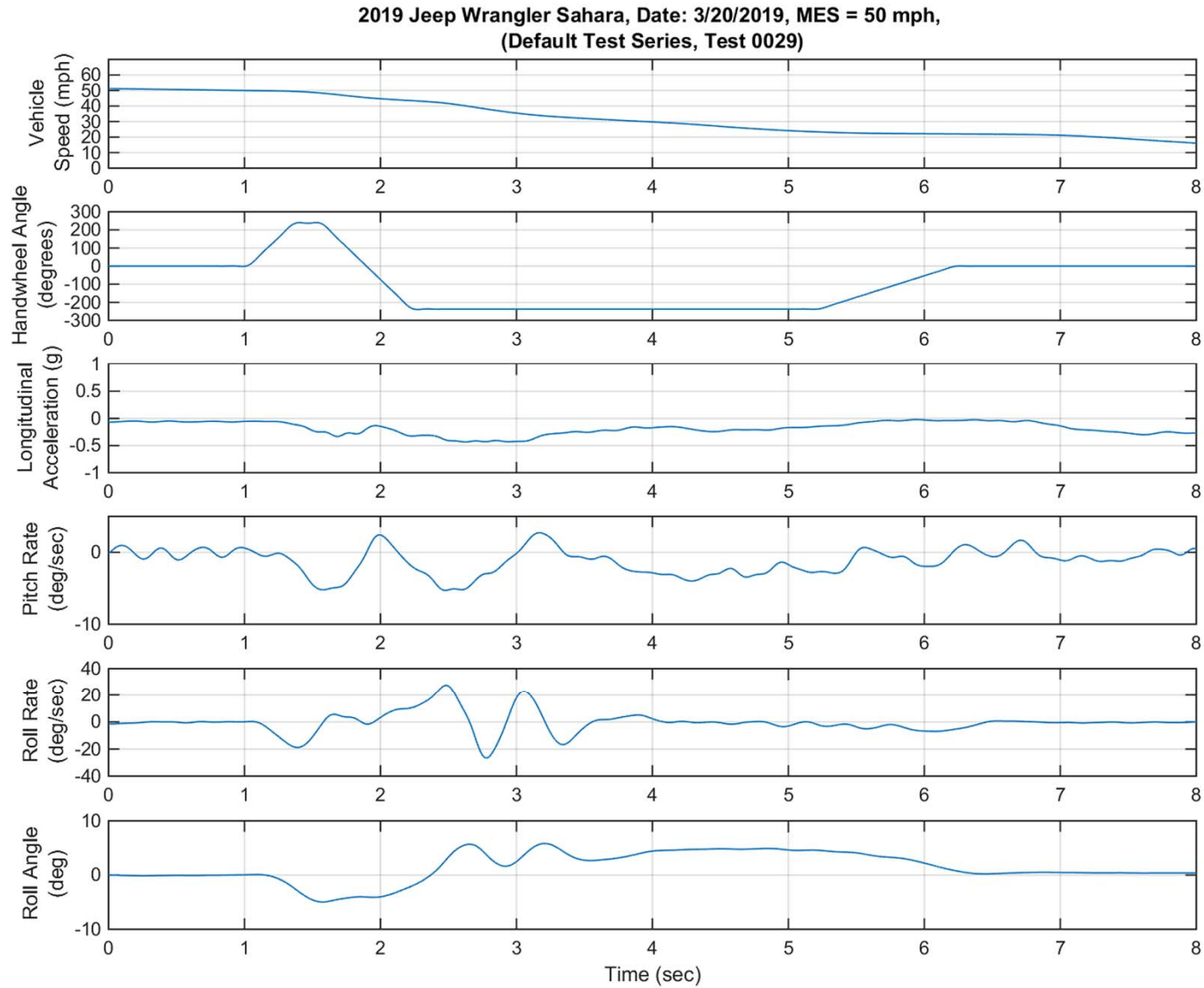

Figure D16. Pitch Rate and Longitudinal Acceleration Time History Plots for Supplemental 2 Test Series, R-L, 50 mph